



ASL Technologies, LLC

E-Series Cabinet

Operations

and Maintenance

Manual

ASL Technologies, LLC Quality Policy

ASL Technologies, LLC was founded with the commitment to be the industry leader in product quality, customer service and customer satisfaction in the market places we serve. Our patented product line of Electrostatic Fluid Filtration equipment is designed, built, tested and delivered with these goals in mind.

Congratulations on the purchase of your new **Finite Particle Removal System™**

ASL Technologies FPRS E-Series Units provide state of the art fluid filtration that allows superior filtration capability at a minimum investment. Affordable electronics and compact design are combined to provide economic filtration without compromising the effectiveness of electrostatics. Though compact in size, the E-Series can provide up to a year of replacement free filtration. It also provides effective cost recovery of valuable fluids and extension of component life in hydraulic, dielectric, and solvent systems.

ASL encourages you to read through this manual completely. Information has been provided in order that our customers can experience the maximum benefits resulting from extreme fluid cleanliness. Every situation cannot be anticipated and ASL is always available to help in any way possible. Critical information has been supplied to assist you with the theory, operation, and maintenance of the E-Series Finite Particle Removal System.™ Questions or concerns should be addressed to ASL.



Table of Contents

Subject	Page
Quick Startup Guide	3
Important Safety Information	4
System Overview	6
Important Guidelines	8
System Preparation	9
Installation Considerations	10
Brief Operational Explanation	14
Microammeter Usage Guide	15
Cell Backflush Operation	16
Cell Removal/Installation	17
Water Absorber Replacement	18
Cell Rebuild Program	19
Warranty Information	20
Product Specifications	21
Parts Ordering Information	22
Spare/Replacement Parts	23
Wiring Diagram	24
Fluid Maintenance Procedures	25
Troubleshooting Chart	26
Fluid Flow Diagram	27
Component Locations	27
Cabinet Dimensional Drawings	28
Hydraulic Pump/Motor Service Data	30
Hydraulic Pump Vendor Service Manual	31

Quick Startup Guide

This section is intended for experienced users only! Please be sure to read the entire manual!

1. Unpack FPRS Unit from shipping box/skid.
2. Open Top cover by grasping rolled lip and pulling toward you and lifting up, like a car hood. Swing the top cover all the way back to the stop. The cover is hinged at the top rear sides, and held closed with magnets. Use caution when the top cover is open, shock or jarring may cause it to close suddenly and could cause personnel and/or equipment damage.
3. Remove front cover by pulling the top rolled edge toward you about 3 inches to disengage the magnets, and lift front cover clear of unit. The front cover fits outside the case sides and rests inside the case at the bottom.
4. Remove service manual package and optional backflush hose package.
5. Check for any loose hoses, electrical connections, etc. that may have occurred during shipping. (A laminated wiring diagram is pasted on the inside of the front cover)
6. Verify that the Throttle valve on the inlet side of the water absorber canister is OPEN.
7. Verify that the W/A drain valve on the bottom of the canister is CLOSED.
8. Remove the plastic ½" NPT shipping plugs from the right side inlet and outlet bulkhead fittings. Plumb inlet and outlet hoses to your reservoir. Use Teflon tape or equivalent (Inlet to the lowest point on the reservoir, and outlet to the opposite side top of the reservoir) Make sure to drain any free water that may have accumulated at the bottom of your reservoir.
9. Unwrap the power cord and connect to a grounded 10 amp 120 VAC outlet. Note that the FPRS unit and your system reservoir must both have earth ground.
10. Reinstall the front cover and close the top cover. (There is a safety switch on the top cover, that must be closed to allow incoming power to reach the power supply)
11. Observe that the red light on the power supply "OFF" switch is lit. Press the "ON" switch on the power supply for two seconds. The red light goes out, and the green light in the "ON" switch is lit.
12. Note that the pump may need to be primed before any outlet flow is observed.
13. The E-Series pump will only "lift" fluid about 24 inches.
14. Your system was tested with fluid, but the water absorber element and the Electrostatic cell are dry when you receive your unit. It may take a few minutes for them to fill, before any fluid output is seen. If output flow and/or pressure rise on the system gauge is not observed within 3-4 minutes, turn power off and make sure the inlet hose is primed.

IMPORTANT SAFETY INFORMATION

READ CAREFULLY BEFORE ATTEMPTING TO ASSEMBLE, INSTALL, OPERATE OR MAINTAIN THE FINITE PARTICLE REMOVAL SYSTEM™. PROTECT YOURSELF AND OTHERS BY OBSERVING ALL SAFETY INFORMATION. FAILURE TO COMPLY WITH INSTRUCTIONS COULD RESULT IN PERSONAL INJURY AND/OR PROPERTY DAMAGE. RETAIN THESE INSTRUCTIONS FOR FUTURE REFERENCE.

SAFETY ALERT SYMBOL AND SIGNAL WORDS

The following safety alert symbol and signal words are used throughout this manual to call attention to and identify different levels of hazard and special instructions.

 This safety alert symbol is used with signal words **WARNING** and **CAUTION** to call attention to safety statements.

 **WARNING!** statements identify procedures or practices, which must be followed to avoid serious personal injury or loss of life.

 **CAUTION!** statements identify procedures or practices, which must be followed to avoid minor personal injury or damage to this equipment.

ELECTRICAL SAFETY

 **WARNING! ELECTRIC SHOCK can kill.** Your FPRS uses a high **Direct Current** voltage of **15,000 volts**. Do not touch live electrical parts. Always disconnect power source before working on the system.

Avoid accidental starting. Make sure unit is turned “OFF” and is unplugged or disconnected from its power source before beginning any maintenance tasks.

This product must be earth-grounded to operate safely and properly.

This product is not explosion proof. Do not use near combustible or highly flammable materials. **Electrostatic arcing is a potential ignition source.**

Protect the power cable from coming in contact with sharp objects. Replace or repair damaged or worn cords immediately.

Safety devices such as interlocks, fuses and circuit breakers should not be disconnected or shunted out.



CAUTION! The power source must be fused for 10 amps.

1. The motor is designed for operation on the voltage and frequency specified on the motor nameplate.
2. Normal loads will be handled safely on voltages not more than 10% above or below the specified voltage.
3. Running unit on voltages not within range may cause overheating and motor burnout.
4. Heavy loads require the voltage at motor terminals be not less than the voltage specified.

Follow all local electrical and safety codes, as well as the National Electrical Code (NEC) and the Occupational Safety and Health Act (OSHA).

Install and maintain equipment according to USA Standard C1, National Electric Code.

Do not install FPRS unit's outdoors or unprotected from the elements. Do not use in a damp or wet location.

FLUID SAFETY



WARNING! Do not pump flammable or explosive fluids such as gasoline. Do not use in explosive atmospheres. Failure to follow this warning can result in personal injury and/or property damage and will void the product warranty.



CAUTION! Secure the discharge line before starting the system. An unsecured discharge line may whip, causing personal injury and/or property damage.

Explosive or flammable (flash point below 200° F) fluids must never be filtered with this product. **Electrostatic arcing is a potential ignition source.** Please refer to Fluid Specification prior to filtering fluid.

- ~ Do not exceed **40 psi** on any components in the system.
- ~ Protect fluid lines from damage or puncture.
- ~ Maximum fluid temperature should not exceed 150°F. The filter cell body can distort at higher temperatures, draining the reservoir and creating a floor hazard and severely damaging the hydraulic system.

INTRODUCTION

SYSTEM OVERVIEW

The Finite Particle Removal System,™ Patent Numbers. 5,149,422, 5,242,587 and 5,891,315, uses the most advanced technology available to clean and reuse oil (i.e., transformer, hydraulic, turbine) and solvents.

There are basically five (5) major factors contributing to the contamination of industrial fluids:

- Air
- Heat
- Water
- Particulate matter
- Oxidation of by products

Contamination of industrial fluids is a great concern because their condition is directly related to the condition of the overall system they function in. Controlling these five factors is foundational to maintaining a trouble-free system.

The following preventative measures do much to extend the life of the fluid and the hydraulic system. One must minimize the external ingress of air and particulate in the fluid. Breather bags and air intake filters have been used effectively for this purpose.

Maintaining the fluid temperatures within the specified limits can be achieved through proper care and maintenance of the cooling system. We have equipped your filtration system with continuous water removal capability to prevent build up due to condensation to keep the fluid dry.

Finally, the fluid must be kept as clean as possible, not only by removing particulate such as:

- Dirt
- Fibers
- Wear metals

Also, the **Submicronic Contaminants** such as:

- Silts
- Tars
- Varnishes

Tars and Varnishes are the byproducts of oxidation and typically occur and are encouraged because of the presence of air, heat and water. Oxidation is usually observed in lubricants and hydraulic oils and results in the formation and deposition of tars and varnishes on the components of the hydraulic system. Removing these contaminants continuously from the system will prevent the majority of problems that plague maintenance departments and cause expensive downtime. Keeping the fluid as clean as possible is what this product will accomplish for you and your company.

ASL Technologies, LLC

10525 W US Hwy 30, Bldg. 3D, Wanatah, In. 46390

Phone 219.733.2777 or Toll Free 888-333.2990

E-Series Cabinet

Facsimile 219.733.2779 or e-mail custsvc@aslfilter.com

www.aslfilter.com

The FPRS is designed to connect directly to your machine's reservoir. The FPRS draws the fluid into its system using a pump that sends the fluid through a water absorber and an electrostatic cell to accomplish the cleaning process. The fluid is then discharged through an output hose and back into your reservoir.

The FPRS utilizes a combination of electrostatic and magnetic fields to remove submicronic particles from non-flammable oils. This is accomplished by electrically influencing the particles in the oil to opposite polarities. These + and - influenced particles are attracted to one another and are retained by polyester foam used within ASL's patented electrostatic cell. Because the foam is polyester, water in concentrations of 500 ppm or less will not disrupt normal operations, although microamp readings of the fluid will be slightly higher due to the conductivity of water.

The cell operates with alternating electrostatic and magnetic fields. If, for example, a particle is negative, it will seek the positive side of a magnetic plate. When the particles begin to collect together, one on top of the other, alternating as positive and negative particles, the polyester foam filter inside the cell becomes a home for the particles and holds them in place. This collection of particles is a phenomenon known as "*strawing*."

Your FPRS comes equipped with a water absorption unit that can remove free and emulsified water down to **25ppm**. This feature covers a wide range of water problems. For very high concentrations of water or very large reservoir, ASL has available water absorber carts and coalescer carts.

Each fluid to be cleaned has its own characteristics, which require modifications in voltages, amperages, magnetic field density and the dedicated collection media used within the electrostatic cell. The cell provided in your unit has been built to meet your specific requirements. Therefore, when discussing your unit with us or when ordering cells, be sure to state the correct model number of the cell. The model number is shown on a red tag on top of the cell, i.e. R61CS-115, R62CS-100, etc.

The long-term benefits of continuous filtration with this product, as the contaminants are purged from your system, will become evident through reduced downtime and maintenance expenditures, extended machine life and improved fluid life. Coupled with our water absorber this product will protect the lifeblood of your hydraulic system from three of the five major factors that contribute to fluid degradation.

- Water
- Particulate Matter
- Oxidation of by products

IMPORTANT GUIDELINES

Oil temperature should not exceed 150°F for electrostatic cells..

Viscosity of the oil to be cleaned cannot exceed 1800 SUS. @ 100°F

The minimum flash point of the oil should not be below 100°F

FPRS E-Series units do not automatically restart if input power is momentarily lost.

Concentrations of *water should not exceed 400 ppm*. If in excess, a water absorber should be used to reduce the content to an acceptable level (less than 400 ppm) before the electrostatic cell is employed.

It is recommended the FPRS input hose be connected to or draw from the lowest point of the reservoir. Therefore, when hooking up to a reservoir for the first time or after a period of non-filtration, always drain free water from the bottom of the reservoir before using the FPRS.

The output hose should be returned to the highest point at the opposite end of the reservoir to ensure maximum distance between the input and output hoses.

When installing an FPRS E-Series unit on an elevated reservoir where the lowest fluid level of the reservoir is higher than the FPRS, it is recommended that shut off valves be installed in the line running from the reservoir to the FPRS pump (inlet). As well as the line running from the FPRS back to the reservoir (outlet).

When installing an FPRS E-Series unit above the highest level of fluid of the reservoirs it is required that the pump be primed. Once primed, the pump of the E-Series can be elevated as high as 24" above the highest level of the reservoir.

SYSTEM SAFETY FEATURES

Your FPRS comes equipped with safety features that are designed to provide operator and environmental safety. Following is a brief description of these features.

OVER PRESSURE OF FLUIDS AT LOW TEMPERATURES

If the fluid pressure within the absorber canister rises above normal operating limits, the pressure gauge on the absorber canister will indicate a higher than normal pressure reading. This feature has two stages:

1. At 40 psi, the pump will enter a bypass condition to ensure the pressure in the system does not rise above 40 psi.
2. This conditions can be triggered by several causes:
 - ◆ The system output has become obstructed (i.e., the hose is kinked).
 - ◆ The water absorber element has become saturated with water.
 - ◆ The temperature of the oil being filtered has dropped. (cold oil)
3. The top cover has an interlock switch that interfaces with the front cover. The unit will not operate with the top cover in the up position and/or with the front cover removed.

SYSTEM PREPARATION

NOTE: IT IS EXTREMELY IMPORTANT THAT THE FOLLOWING STEPS BE DONE IN ORDER TO ENSURE PROPER SET-UP AND OPTIMUM RESULTS FROM THE FPRS!



CAUTION! Before making power connections to this ASL unit, check the polarity of your power source. ***Also verify that earth ground is present.***

Open the hinged top cover, (two magnets hold the cover closed) and swing it back. Remove the front cover by pulling it toward you (also held in place with magnets) and lifting it out of the way, to expose the internal mechanisms.

Check the wire and hose connections to and from the FPRS. It is important that these connections are tight and have not shaken loose during shipment. Tighten the connections if they are loose. ***Do not over-tighten.***

Check the quick disconnects on the cell to ensure that they are locked in place. (The outer ring of the quick disconnects slide back to lock and unlock the disconnect.)

The E-Series CABINET models will not operate with the front cover removed.

Take a sample of the fluid to be cleaned.

- ◆ Use a clean bottle to take the sample.
- ◆ The sample should be taken from the lowest point of the reservoir, preferably the drain cock or valve, because this is where the FPRS input hose will draw from. Free water should be drained from the reservoir before the FPRS is hooked up.
- ◆ Test the sample to ensure that the fluid does not surpass the guidelines of the system as set forth in this manual.
- ◆ For in-service oil analysis, a sample port has been provided, and is located at the inlet to the water absorber canister, just below the pressure gauge.

INSTALLATION CONSIDERATIONS

APPLICATION COMPATIBILITY

While this product can provide effective filtration over a wide range of applications, there are some applications that are an exception.

- Type of fluid to be filtered.
- Contamination source or sources.
- The rate of contamination.

The following guidelines should be considered before installing this product.

1. Fluid Specification—this product is suitable for filtering nonconductive and semi-conductive fluids with viscosity rating less than 1800 SUS @ 100° F. ***Water based fluids cannot be filtered with this product.***

Typically compatible fluids include:

- Petroleum-based lubricants
- Solvents
- Synthetic lubricants
- Dielectric fluids

Check with supplier prior to filtering fire-resistant lubricants as these are extremely destructive to plastics and seal materials. Any questions can be addressed to the manufacturer.

2. Contamination Type—non-discrete type contamination cannot be filtered with electrostatics. This includes contamination from other fluids or chemical property altering contaminants. Systems with chronic water ingress cannot be filtered effectively unless the source of water can be eliminated or greatly reduced to less than 400 ppm.
3. Contamination Rate—systems that produce excessive contamination may quickly overwhelm this product, especially if the contaminant is conductive (i.e. EDM, grinding and polishing systems, etc..)

The FPRS is now ready to be charged (filled) for operation and tested to ensure that no connections have loosened during shipment. The FPRS should be charged with the same fluid it has been designated to clean.

INSTALLATION

APPROPRIATE LOCATION

Avoid locations that expose this product to excessive moisture and explosive environments. This product generates an electrostatic field that may disturb or damage sensitive electronic equipment. Also, remember that access to this product is required periodically to replace the electrostatic cell. Finally, avoid installing in high traffic areas where this product may be easily damaged by vehicles, forklifts, etc.

SYSTEM CONSIDERATIONS

1. Main Power Supply Source

- ◆ 120 volts AC, 60 Hz, single phase.
- ◆ 10 amps Circuit Breaker.
- ◆ 16 ga. Power cord provided.
- ◆ Optional flexible grounded conduit for mobility.
- ◆ Earth Ground.
- ◆ Vertical Orientation

2. Fluid Delivery

Pump/Motor --A pump and motor delivery system allows for continuous filtration, even during machine downtime. Installation is convenient and maintenance does not require shutting down the hydraulic system. A pump /motor assembly is provided which is designed to be compact, and is for continuous-duty, maintenance free and has been sized for the correct flow rate.

3. Hydraulic Connections

All the connections between the reservoir and the cabinet can be with hard-piping or hose connections. On the E-Series units, we have provided ½ ” NPT bulkhead fittings for your convenience on the side (for Cabinet models) and on the back for Panel Models.

4. **Mounting Surface**

The E-Series Cabinet Model has cooling vents on both the back and bottom, allowing wall mounting, or floor placement. For wall mounting, keyhole slots are provided on the back panel of the unit. An optional floor dolly can be purchased or fabricated locally, to provide mobility of the cabinet to so it can be moved for servicing machinery that it is in close proximity. However you decide to mount the cabinet, allow 6 inches of space between the back or bottom louvers for pump/motor cooling.

5. **Remote Alarm**

If a signal is desired to provide remote indication of an alarm condition, the E-Series Cabinet Models provide dual quick—connect interface with an internal dry relay contact to interface with a signal not exceeding 24 volts. The relay is closed during normal system operation. During an alarm condition, such as overload, the relay will open. A second access hole is provided if hardwiring is required by your electrical codes. These connections are located on the right side of the cabinet, just below the power cord.

6. **Water Absorption**

Equipping the filtration system with water absorption capabilities maintains constant fluid dryness and prevents moisture build-up from condensation in the reservoir. The E-Series units are equipped with a water absorber unit that is installed between the fluid delivery system (pump) and the cell. This filter will also trap contaminants 5 microns and larger, and should be replaced whenever water content increases, or pressure rises above 30 - 35 psi. Replacement elements are available from ASL.

7. **Power Interrupt**

The 'E' Series units do not automatically restart if input power is momentarily lost. Under normal conditions, a control signal from the high voltage side of the power supply holds the start relay energized. Momentary dips and/or sags in input voltage as well as harmonics caused by step down transformers, may cause a loss of the control signal, resulting in system shutdown, which will require a manual restart. Press the Control Module "ON" switch and observe that the red light goes out and the green light comes on and remains on. **Units with the "-A" power supply modification (check the power supply name tag for "-A" after the CS-2224-A50 part number) have a power on holding circuit, which holds the start relay closed for 1 and ½ seconds if power is momentarily lost. When shutting down these units, press and hold the "OFF" button for at least two seconds, until the RED light in the power supply "OFF" button illuminates. This modification was production line incorporated starting with serial Number 1030, and may have been retrofitted on earlier units.**

HOSE CONNECTIONS

It is recommended that connections to reservoirs be made with quick disconnects to minimize ingress of contaminants when hooking up and operating the FPRS.

- ◆ Connect the input and output hoses to the FPRS.
- ◆ Connect the input hose to the fluid reservoir. If there is no place to secure the hose, simply place the hose in the fluid near the bottom of the tank.
- ◆ Place the output hose into the fluid reservoir at the top of the tank
- ◆ When installing an FPRS E-Series on an elevated reservoir where the lowest fluid level of the reservoir is higher than the FPRS, it is recommended that shut-off valves be installed in the line running from the reservoir to the FPRS pump (inlet). Also, the line running from the FPRS back to the reservoir (outlet).



CAUTION! HANDLE THE HOSES SO THAT SPILLS CANNOT TAKE PLACE.

SYSTEM START-UP

- ◆ Connect the FPRS to a grounded **120VAC**-power source.
- ◆ Both the FPRS and the hydraulic system reservoir must have earth ground.
- ◆ Ensure that the shut-off valves on the input and output lines are open.
- ◆ Locate the drain valve on the water absorber and verify it is in the closed position.
- ◆ Place the front cover in position and close the top cover. (Cabinet Models)
- ◆ Push the **ON** switch on the power supply. The red light on the OFF switch will go out and the green light on the ON switch will illuminate and stay on.
- ◆ The FPRS pump will start running, and draw fluid from the reservoir into the FPRS.
- ◆ Check for any external leaks.
- ◆ Push the **OFF** switch on the power supply.
- ◆ Open the top cover and remove the front cover.
- ◆ Check to ensure there are no leaks internally.
- ◆ Locate the red tag on top of the cell. Fill in the “**Date Installed**” in the space provided. This will assist you in determining when an annual cell exchange may be required.
- ◆ Replace the front cover and close the top cover.

You are now ready to begin normal operations.

NORMAL OPERATION

Your FPRS system has been designed to operate continuously on a fluid reservoir with little operator attention. However, it is recommended to check the control panel daily to monitor system condition. Note that E series units do not automatically restart if there has been a momentary power interrupt.

During normal operation, the front panel should display the following:

- ◆ The green “POWER” light should be lit.
- ◆ The “Pressure Gauge” on the water absorber canister should read between 2 and 30 psi. This gauge shows how much water and/or particulate matter has accumulated within the canister and is a way to predict when an element change is imminent.
- ◆ The “microampmeter” should read between 0 and 300. This gauge shows the general condition of the Electrostatic cell, and is a way to predict when cell backflushing or replacement is required.
- ◆ Note that the hourmeter receives power from the pump/motor start signal, and will only be operating when the pump is receiving power.

Brief Operational Explanation:

When power is applied to the system, 120VAC flows to the power supply module via the black wire. This lights the red light on the power supply “OFF” switch. In this condition, the system is either ready to operate, or an alarm condition or power outage has occurred. Note that if power is interrupted to the FPRS, you will need to re-start the system by pressing the “ON” switch. Once the inlet and outlet hoses are connected, the operator presses the “ON” switch on the power supply module. When the power supply High Voltage section (15,000 VDC) is ready to operate, (a few milliseconds) a relay inside the power supply closes, sending 120VAC through the red wire to the hourmeter and the pump/motor. At the same time, 15,000 VDC is applied to the terminals of the electrostatic cell. The pump starts and draws fluid into the system from the users fluid reservoir. The fluid then passes through the water absorber/prefilter. The inlet pressure gauge (visible through the hole in the front cover) should read about 2 -10 psi when the system is new. As the pre-filter accumulates water and dirt (5 microns and larger) the pressure will rise. When the gauge reads approximately 35 psi, it is time to change the water absorber/prefilter element. Note that the pump is set at the factory to “bypass” at approximately 40 psi. to prevent over pressure conditions in the unit.

After passing through the prefilter, the fluid then enters the electrostatic cell at the bottom (Blue hose) where contaminants are charged alternately positive and negative, stick together and are “strawed” into holding foam within the patented electrostatic cell.

MICROAMMETER – YOUR MOST IMPORTANT TOOL

The microammeter, located on the front panel next to the hour meter, indicates, in micro-amps, how much current the Electrostatic Cell is pulling from the high voltage power supply. The microammeter shows the general condition of the cell and is a good way to predict impending maintenance actions.

At approximately 500 microamps, shut down the system and backflush the Cell in accordance with the instructions on page 16 of this manual. Note that under normal operating conditions, the microammeter will rise slowly toward 500, giving maintenance adequate warning that backflush time is approaching. Note that the system will continue to operate beyond 500 microamps, all the way up to 700 microamps, when the system shuts down. Operation above 500 microamps for any extended period of time is not recommended, and the cell should be backflushed or replaced as soon as practical.

The microammeter on your FPRS system should be checked frequently. When the system is new, and the oil in your reservoir is clean, microamp readings will be low. Normally, the meter will climb very slowly over time, and may take months to reach 500. On other systems, the meter could start at 200 and slowly climb, or even go down over time. The main thing to watch for is erratic movements, rapid climbing, etc.. A rapid climb most always indicates water has entered the system, and finding and correcting the source of the water intrusion should be paramount. Once water has entered the Electrostatic Cell, concentrations of 600 ppm and higher, will short it out rapidly. Replacement of the water absorber and Backflushing the Electrostatic Cell (perhaps several times) will restore proper operation.

Changes in microammeter readings will also occur under the following fluid conditions:

1. **HEAT** – Current Increases. Fluid temp. will cause the uA to increase. A rise from 80°F to 110°F can sometimes double the uA. In turn, as fluid temp. decreases, so will the uA.
2. **COOLING** – Current decreases.
3. **WATER** – Water can make the “base current” appear higher than it really is.
4. **VARNISH** – Although the Electrostatic Cell is capable of capturing a lot of varnish before it will effect the operation of the Cell, at some point, as the oil oxidizes, varnish will cause the efficiency of the cell to decrease, and the Cell will need to be replaced.

The Electrostatic Cell must be replaced at one-year (8700 operating hours) intervals to maintain peak performance, The number one cause of high voltage power supply failure, is operation of an Electrostatic Cell beyond 8700 hours.

CELL BACKFLUSH OPERATION

Backflushing of the cell is unique to the Finite Particle Removal System™. This operation allows the cell to be reused without being replaced under normal use. (*Under normal operation, electrostatic cell and water absorber should be changed annually*)

When the cell becomes filled with contaminants, (about 500 microamps) and/or the red light turns on, the cell needs to be backflushed.



1. **WARNING!** Turn OFF the FPRS on the control panel and at the electrical source.
2. Disconnect the input and the output hoses from the cell and set aside.
3. Connect a backflush hose to the quick disconnect at the bottom of the cell.
4. Place the end of the bottom backflush hose into a 5-gallon pail.
5. Using a second backflush hose, connect plant air supply (**REDUCE TO 10 PSI**) to the quick disconnect at the top of the cell.
6. Allow 10 psi of air to flush the contaminants out of the cell and into the pail for disposal.
7. Leave the air pressure on until contaminants are no longer dispensed out of the backflush hose. (10 minutes)



CAUTION: BACKFLUSH HOSE WILL JUMP AROUND AS AIR REACHES IT!

8. Remove the backflush hoses and replace the input and output hoses to the top and bottom of the cell at their original configuration, blue hose to the bottom of the cell disconnect and gray hose to top of cell. (The top of the cell connects directly to the bulkhead output fitting)
9. Turn **ON** the electrical service to the FPRS™
10. Restart the system and check the red light to ensure that it has gone out. If it remains on, refer to the “**Trouble Shooting**” section of this manual.
11. Observe that the microamp meter is now below 500 microamps.

CELL REMOVAL

Under normal operating conditions, cells should be changed out **annually**. When you replace your electrostatic cell, perform the following steps:



1. **WARNING!** Turn **OFF** the FPRS on the control panel and at the electrical source.
2. Open the top hinged cover, and remove the front cover.
3. Disconnect the high voltage wires as follows:



4. **WARNING!** Short across the positive and negative electrodes using a screwdriver with an insulated handle to dissipate static electricity.



5. **WARNING!** Each cell has a **positive (red)** lead and a **negative (white or green)** lead connected to it. **NEVER** touch both leads at the same time.
6. Disconnect the high voltage wire connections leading to the top of the cell; **using one hand**, grasp the boot connected to the white or green wire and pull up. Repeat with the boot connected to the red wire.
7. Remove the input and output hoses by releasing the quick disconnects.
8. Loosen 4 attaching screws from outside of the cabinet and lift the cell out of the cabinet.
9. Replace with a new or rebuilt cell. Ensure that the cell is inserted correctly with high voltage electrodes pointing upwards.
10. Attach quick disconnect with blue hose to the bottom of the cell and gray hose to the top of the cell.
11. Replace the high voltage wires to the cell. **Red is positive, White or Green is negative.** The label at the top of the cell notes the positive and negative electrodes. Be sure to fill in the “**Date Installed**” on the cell tag.
12. Replace the front cover and close the hinged top cover.
13. Restart the FPRS and operate system for a few minutes. Ensure that fluid is being dispensed through the output hose.



14. **WARNING!** Once fluid is dispensed through the output hose, turn **OFF** the FPRS on the control panel and at the electrical source.

15. Open the top cover and remove the front cover and check for leaks.

Replace the front cover and close the top cover. The FPRS is now ready to resume operation.

CHANGING WATER ABSORBER ELEMENT

1. If the pressure gauge on the water absorber element is above its normal running pressure, it may need to be replaced. (35 – 40 psi)



WARNING! Turn **OFF** the FPRS on the control panel and at the power source.

2. Open the top cover, and remove the front cover.
3. Remove the top and bottom hoses from the cell at the quick disconnects.
4. Backflush cell. (See proper procedure in this manual)
5. Reattach only the blue hose to the bottom of the cell. Leave the top hose disconnected.
6. Close the valve between the pump and the absorber canister.
7. Locate the absorber drain hose. (It is folded over and tie-wrapped) Cut the tie-wrap and place the hose in a pail. Open the drain valve on the bottom of the absorber canister.



CAUTION: DRAIN HOSE WILL JUMP AROUND AS AIR REACHES IT

8. Apply 5-10 lbs. air pressure to the top of the cell.
9. When the oil flow stops, disconnect the air pressure, loosen the Clamp at the top of the canister and remove the lid.
10. Remove the element hold down bolt, and lift out the old element by the wire handle.
11. Unpack the new element and install into the canister.
12. Re-install the element hold down bolt, hand tight.
13. Clean the 'O' ring, and apply a thin coat of your oil. Replace the canister lid and clamp.
14. Close the drain valve on the bottom of the absorber canister, and stow the drain hose.
15. Re-connect the cell hoses, Gray to the top, Blue to the bottom. Open the valve between the pump and the absorber canister.
16. Replace front cover, and close top cover.
17. Activate the main power source, and then turn **ON** the power switch on the control panel.
18. After fluid is dispensed through the output hose, shut down the system and check for leaks inside the cabinet.

Electrostatic Cell Rebuild Program

The Electrostatic Cell in your FPRS™ (Finite Particle Removal System) was designed to provide many hours of superior filtration. Like anything else, it occasionally needs care and maintenance. It is recommended that the Cell be rebuilt once each year to insure optimum cleaning performance. The rebuild/exchange program has been organized to provide minimum downtime and maximum performance.

All re-built Electrostatic Cells contain all new internal parts, and are subjected to the same final testing criteria as the new cells you received with your ASL FPRS™ system. The only parts re-used (provided they meet spec.) are the end caps and outer tube.

When you receive your Electrostatic Cell, please note that the red tag affixed to the top of the cell contains part number information, as well as the date the cell was made. A blank area is left open for you to fill in the date the cell was installed in your system. This will help you determine when the cell should be exchanged.

When you are ready to replace your Electrostatic Cell, please follow these steps:

1. Look at the red tag on the top of the cell to locate your part number. (R61CS-115, for example)
2. Send your P.O. to ASL via Phone, Fax, mail, or e-mail (custsvc@aslfilter.com) with the quantity and part number requested.
3. When you receive your cell, install it in your unit, and return the used cell in the shipping box. (Please backflush the return cell for 10 minutes at 10 psi to drain as much fluid as possible.)

You should order your re-built cells early so you won't be down, waiting for your new Cells to arrive. Please remember to **backflush returned cells** prior to sending them back to us. This will save you on shipping costs, (a re-built cell weighs 16 pounds, and most Returned cells weigh in at 28 pounds) as well as saving the environment, as we have to dispose of the used, contaminated oil and internal components.

Note that if the used cells are not returned to us within 30 days, you will be invoiced separately for a core charge of \$175.00 for each cell.

If you want to stock spare cells, the core charge can be extended to allow for this.

WARRANTY INFORMATION

ASL Technologies, LLC, (“ASL”) warrants this product to be free from defects in material and workmanship for a period of one (1) year, from date of shipment, excluding expendables, in accordance with the following terms and conditions.

This warranty extends only to the original purchaser (“owner”).

This warranty does not include damage to the product resulting from accident, misuse or abuse, improper installation or operation, lack of reasonable care, or unauthorized repair or alteration.

Should this unit fail during the warranty period, ASL will repair or replace it at our option. Replacement products supplied under this warranty may be new or rebuilt at our option. Labor charges will be without cost to the purchaser (owner) during the first ninety- (90) days of the warranty period, up to 500 hours of operation. Owner will be responsible for all labor charges after this period. Owner will pay for the expense of delivering the product to ASL for warranty work, and expense of returning it to the owner after repair or replacement. ASL will assume no field expense for service or parts unless authorized in advance.

This warranty is the only warranty extended by ASL to suppliers and/or purchasers of this product. No other warranty, written or oral, is authorized. ASL disclaims all other warranties; express or implied that arises by operation of law, except that implied warranties of merchantability or fitness for a particular purpose are limited to the duration of the warranty period. ASL shall not be liable for any incidental, consequential or other damage that may have resulted from any alleged breach of warranty, including any cost or expense of providing substitute equipment or service during periods of malfunction or non-use.

Some states do not allow limitation on how long an implied warranty lasts or the exclusion limitation of incidental or consequential damages, so the above stated limitations or exclusions may not apply to you.

This warranty gives you specific legal rights, and you may also have other rights, which vary from state to state.

For instructions on how to obtain warranty service, contact:

ASL Technologies, LLC
10525 W US Hwy 30, Bldg 3D, Wanatah, In. 46390
Phone 219.733.2777 or Toll Free 888-333.2990
Facsimile 219.733.2779 or e-mail custsvc@aslfilter.com

**PRODUCT
 SPECIFICATIONS
 FPRS E-Series Cabinets
 (See page 28 - 29 for outline drawings)**

PHYSICAL DIMENSIONS:	
Filter Cabinet:	25 1/8" High x 19 3/8" Wide x 15 1/2" Deep (to front of control module)
Cabinet Construction:	14 Gauge Steel
Water Absorber Canister:	14 1/2" High x 5" Diameter
SHIPPING WEIGHT:	105 pounds
GROSS WEIGHT DRY:	100 pounds
GROSS WEIGHT WET:	121 pounds
MOTOR:	1/4 HP
	1725 RPM
	120 VAC 60 Hz, single phase
	4 amps continuous
	6 amps Start up
PUMP:	30 or 40 gph w/100 SUS Fluid @ 1725 RPM
	1/2" NPT, Inlet & Outlet Ports
WATER ABSORBER:	5 micron wood/paper alternate stacked element
INLET & OUTLET CONNECTIONS:	1/2" NPT Bulkhead Fittings
SYSTEM VOLTAGE:	
Input Voltage	120 VAC 60 Hz, single phase +/- 10%
Circuit Breaker (On Control Module)	10 Amps.
Output Voltage of Power Supply	15KV Nominal 1.9 miliamp (+/-600uA)

Manufactured in the U.S.A.

ORDERING SPARE AND REPLACEMENT PARTS

A Spare Parts List for your FPRS is included on the following pages. Prompt service can be given for spare or replacement parts if ASL has the following information:

1. The part number(s) of the item(s) you need. The Spare Parts List includes the most frequently requested items.
2. The quantity needed. Please remember to order spares, if needed.
3. Order fulfillment information:
 - ✓ Preferred shipping carrier information
 - ✓ Regular, Second-Day or Next day Air Service.
 - ✓ “Bill To” Address
 - ✓ “Ship To” Address (we cannot ship to a P.O. Box)
 - ✓ Purchase Order Number

Parts will be invoiced F.O.B. Merrillville, IN, at the prices in effect at the time of the shipment. Terms will be Net 30 days. We also accept Visa, MasterCard, and American Express.

Order Address: **ASL Technologies, LLC**
Parts Department
10525 W US Hwy 30, Bldg 3D
Wanatah, IN 46390

Telephone: **219.733.2777**
Toll Free: **888.333.2990**
Facsimile: **219.733.2779**
E-Mail: **custsvc@aslfilter.com**
Internet: **www.aslfilter.com**

ASL Technologies, LLC

10525 W US Hwy 30, Bldg. 3D, Wanatah, In. 46390

Phone 219.733.2777 or Toll Free 888-333.2990

E-Series Cabinet

Facsimile 219.733.2779 or e-mail custsvc@aslfilter.com

www.aslfilter.com

FPRS E-Series Cabinet Spare / Replacement Parts

DESCRIPTION	PART NUMBER
Control Module (Power Supply)	CS2224A50-A
40 GPH Pump/Motor/coupler ASSY	ASL-83940
40 GPH Pump only	00-LEV-040-A
30 GPH Pump/Motor/coupler ASSY	ASL-83930
30 GPH Pump only	30-LEV-CC-A-9821
Motor only (includes 3 piece coupler)	ASL-88514 (both 30 & 40GPH Models)
Three piece pump to motor coupler only	ASL-1L519
Water Absorber Element	WAEB-12
Water Absorber Housing with lid, clamp and 'O' ring	ASL-5012
Water Absorber 'O' ring	ASL-397-27
Electrostatic Cell	R61CS-115 (See top of cell for your exact part number)
Pressure Gauge	ASL-397-23
Lid Safety Switch	07F 038
Lid/Front Cover Magnet	11242
Hour Meter	711-0130
Microamp Meter	N05843
E-Series Service Manual	E-Series Cabinet Service Manual
Laminated wiring diagram	E-Series-Wiring Diagram
Power supply to cell positive lead, with red boots and terminals, 48 inch length	ASL-8A50-POS
Power Supply to Current meter negative lead, with black boot and terminals, 16.5 inch length	ASL-8A50-NEG-1
Current meter to cell negative lead, with black boot and terminals, 27.5 inch length	ASL-8A50-NEG-2

E-Series "Cabinet" Wiring Diagram

(Unit Serial Numbers ASL-1001 & up)

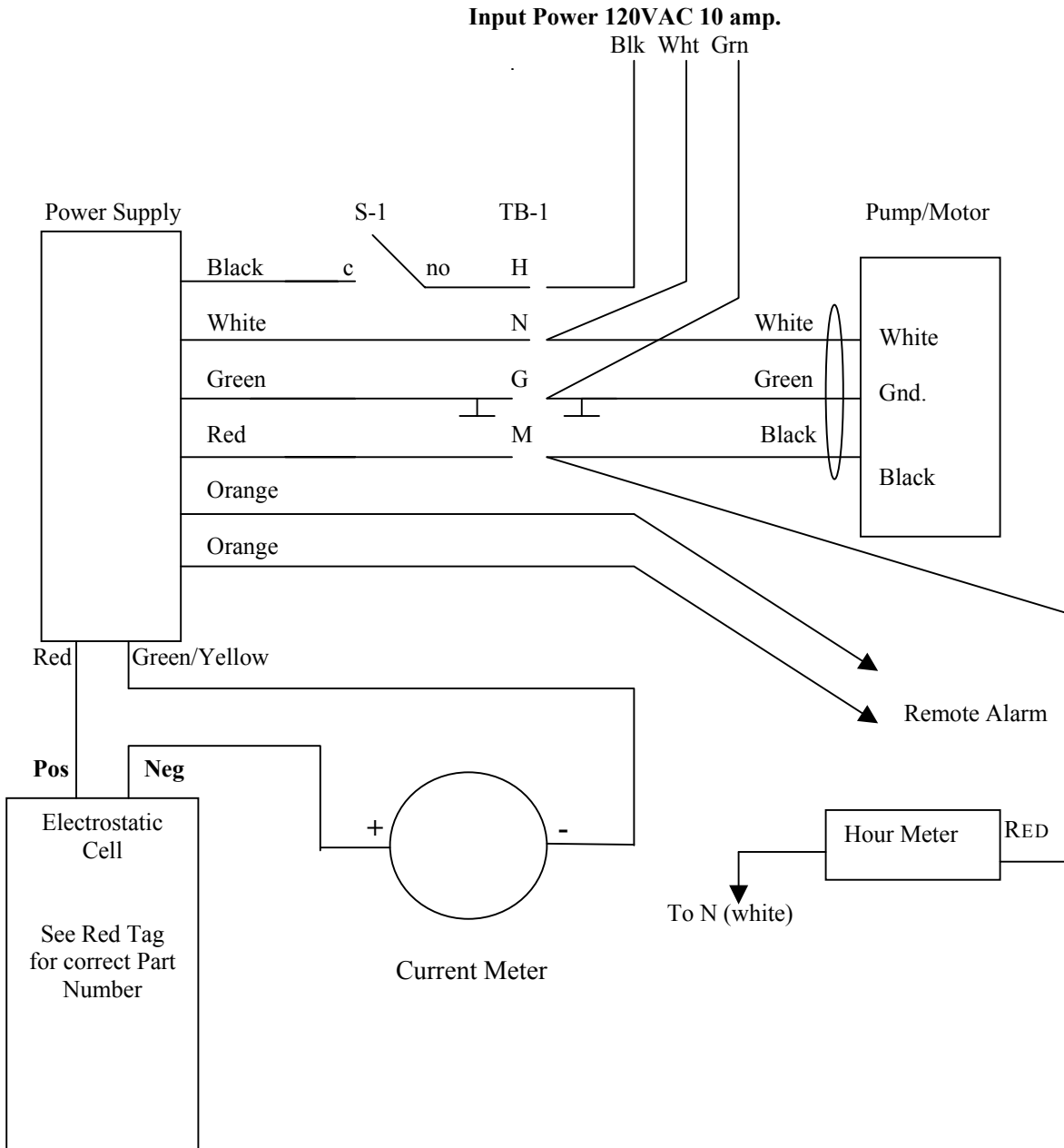

FLUID MAINTENANCE

GENERAL MAINTENANCE

The FPRS is relatively maintenance free if kept dry and operating in ambient temperatures of 95°F or below. Both the control module and filter cell are designed to be replaced completely when found to be faulty. The following recommendations are made in the interest of maximizing the benefits available with the E-Series Units.

1. Periodically check for leaks and possible damage to the Unit.
2. Periodically monitor the condition of the machine fluid. The following is a list of recommended tests that should be performed:
 - ◆ Viscosity
When compared to values for virgin oil, the viscosity gives an indication of excessive thinning or thickening resulting from oil breakdown.
 - ◆ TAN
When compared to values from virgin oil, an increase on the TAN indicates oil serviceability with regard to oxidation or contamination with an acidic product.
 - ◆ Particle Count
Monitors the oil cleanliness level to provide indication of filter efficiency and potential wear failures.
 - ◆ Water
Indicates the presence of moisture of coolant in the oil. For detection of water content below 1000ppm, the Karl-Fischer method can be used.
 - ◆ Spectrochemical Elemental Analysis
The presence of elements in solution, i.e. additives, wear metals and contamination elements.

FT-IR—Estimation of oxidation levels.

PIXIE—Analysis of contaminant residue on patches.
3. When the condition of the oil is in question, it is usually more economic with small reservoirs to simply replace the oil than it is to spend money on extensive testing. Tests should be used to analyze potential problems in the machinery, not necessarily to determine oil life in these cases.

ASL Technologies, LLC

10525 W US Hwy 30, Bldg. 3D, Wanatah, In. 46390

Phone 219.733.2777 or Toll Free 888-333.2990

E-Series Cabinet

Facsimile 219.733.2779 or e-mail custsvc@aslfilter.com

www.aslfilter.com

TROUBLE SHOOTING GUIDE

PROBLEM	POSSIBLE CAUSE	SOLUTION
No Green Power Light	Unit unplugged Circuit Breaker Blown	<ul style="list-style-type: none"> ◆ Plug unit in to power source ◆ Check for possible cause and reengage circuit breaker.
Overpressure on Pressure Gauge/s	Flow restricted down-stream of pump.	<ul style="list-style-type: none"> ◆ Check hoses for kinks. ◆ Check cell quick-disconnects to assure they are properly seated. ◆ Check all in-line valves and assure that they are fully open. ◆ Absorber needs replacing. ◆ Cell needs Backflushing.
Filter Shuts Down Red "OFF" Light is Lit.	Shorted Cell Power Interrupt	<ul style="list-style-type: none"> ◆ Backflush Cell ◆ Check Fluid for presence of water. ◆ If Water Found, replace water absorber and Cell. ◆ Check for cause of power interrupt, and re-start unit.
Filter Shuts Down Red "OFF" Light is Lit.	Faulty Control Module	<ul style="list-style-type: none"> ◆ Replace Control Module.
Filter shuts Down Red "OFF" Light Not Lit	No Power to Control Module	<ul style="list-style-type: none"> ◆ Check for power to terminal board, If OK, Replace Control Module.
Fluid Delivery system (FDS) Shuts Down Green "ON" light is Lit.	Pump/Motor Assembly not Running	<ul style="list-style-type: none"> ◆ Check at terminal board that pump/motor is receiving 110 volts AC (Red wire) ◆ Check power to hourmeter
Filter Operation Normal Fluid Condition Worsens	Water absorber overloaded Cell defective/full	<ul style="list-style-type: none"> ◆ Replace water absorber element. ◆ Backflush/replace cell.
Microamp meter reads 500	Cell Backflush Indicated	<ul style="list-style-type: none"> ◆ Backflush Cell
Microamp meter reads 700	Cell replacement Indicated	<ul style="list-style-type: none"> ◆ Replace Cell

FPRS E-SERIES CABINET FLUID FLOW DIAGRAM

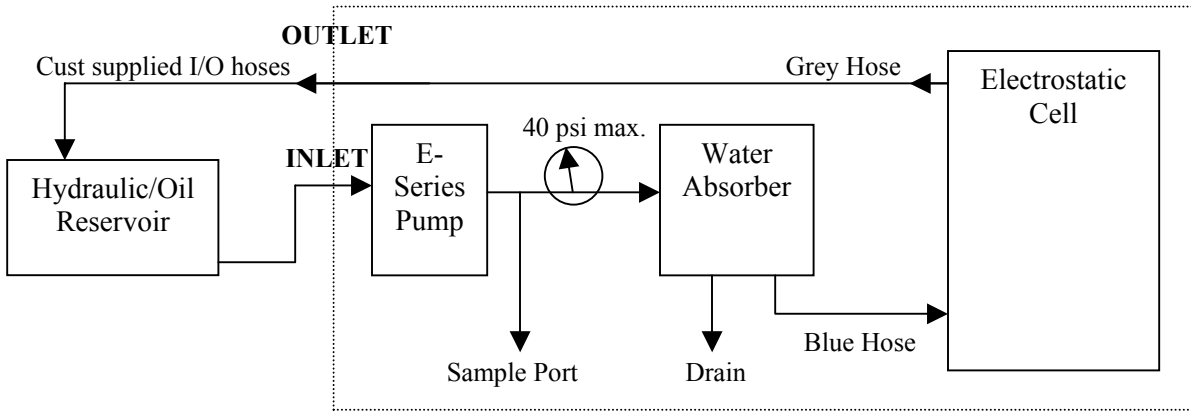

Component Locations

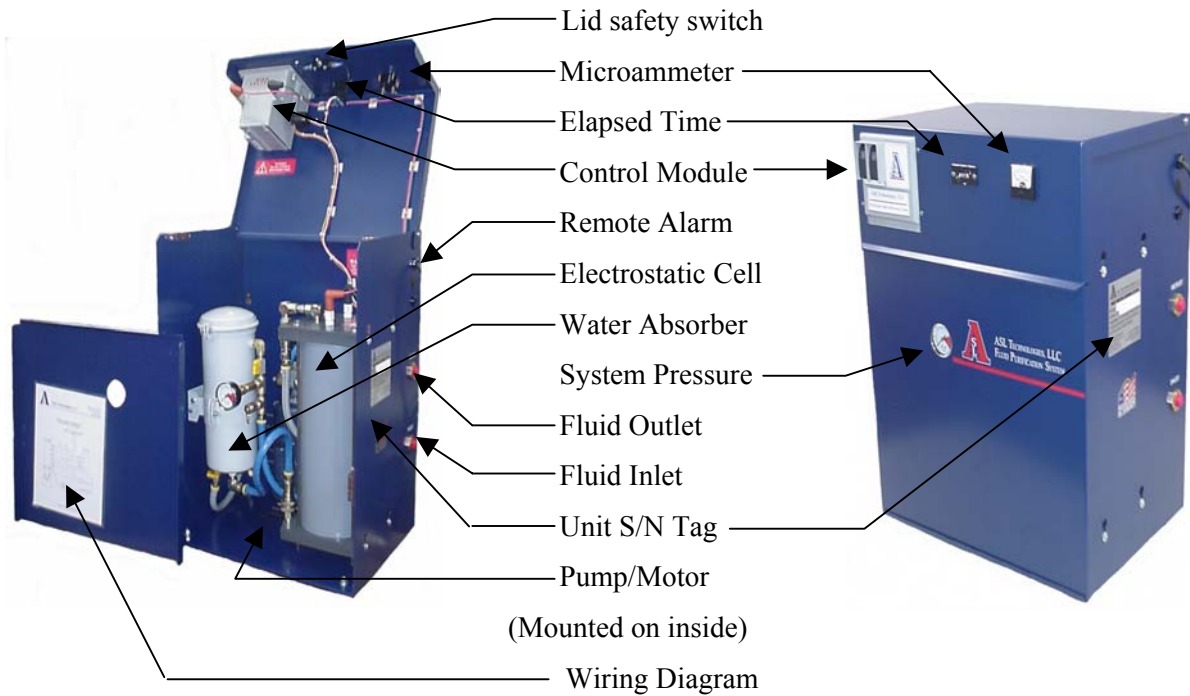

E-Series Cabinet Dimensions
 (Not to Scale)
 (See next page for Lid open dimensions)

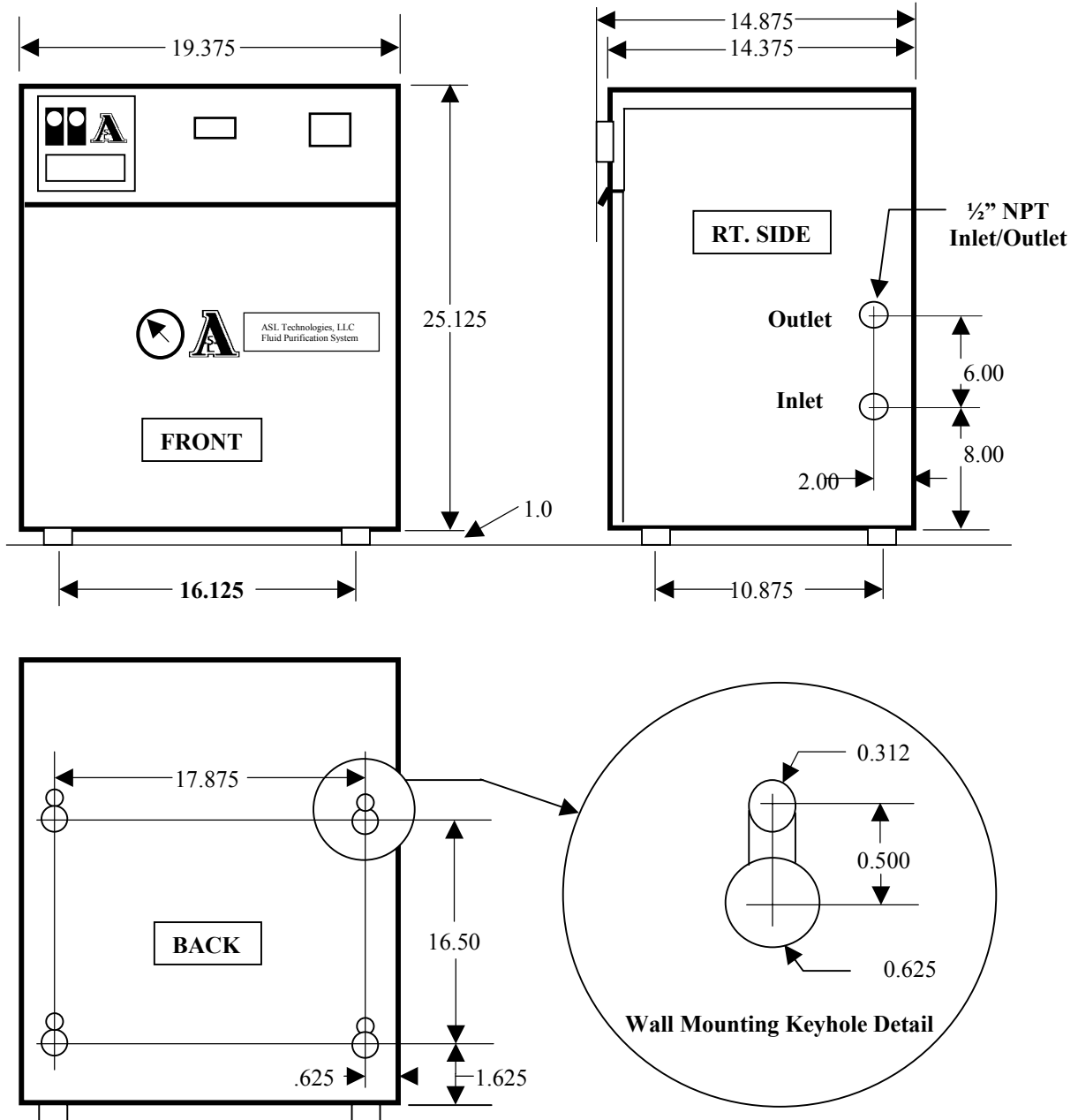

“E” Cabinet Units Right Side View Lid Open Dimensions

(Not to scale)

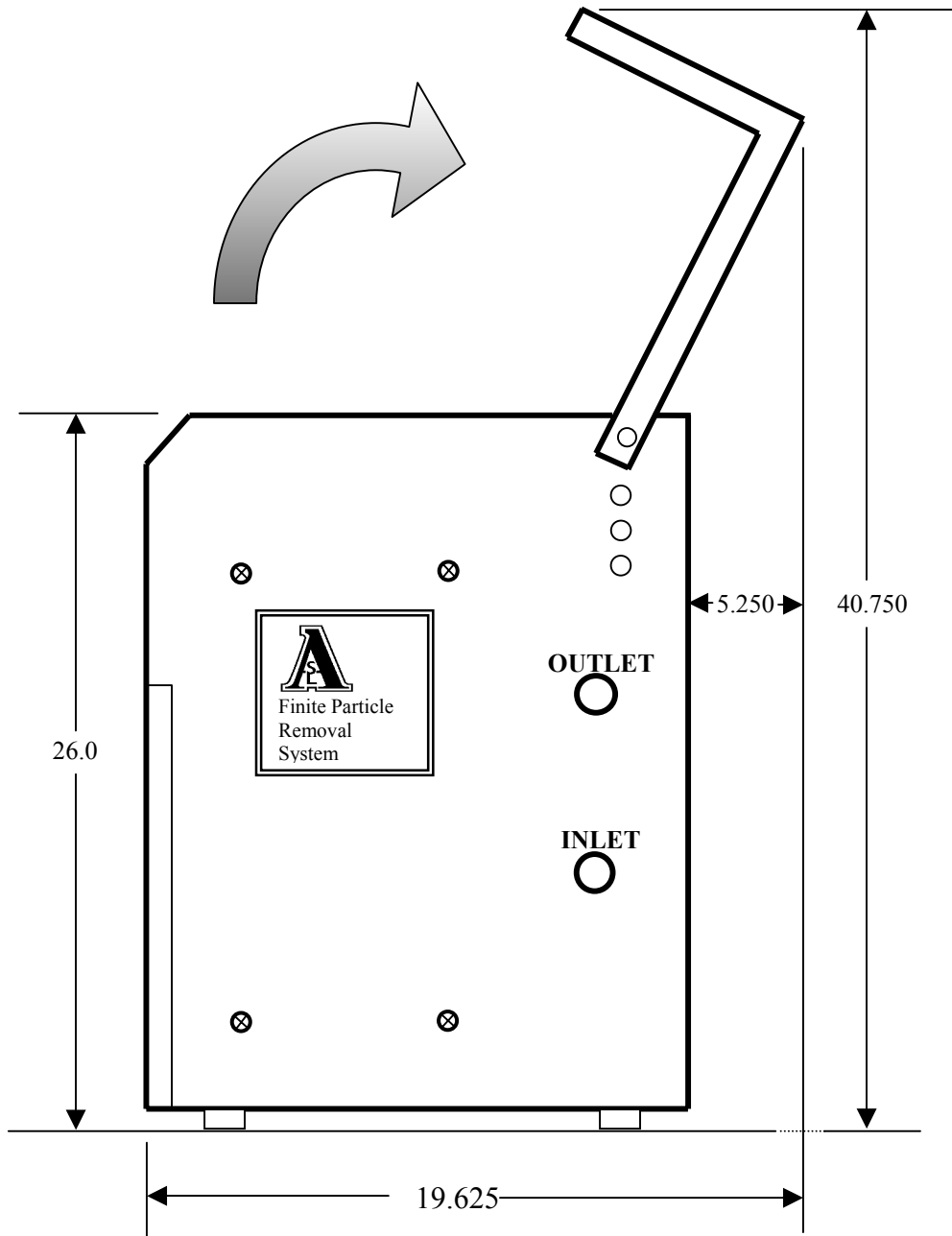

Motor Service Data Nameplate Data, P/N 88514 (Grey Baldor Motor Only)

Model: 34G510-5506	P/N: 88514	
Volts: 115/208-230	Hz: 50/60	KVA Code: L
H.P.: ¼	FR: 48 YZ	Phase: 1
RPM: 1725	SF: 1.35	ENC: TEFC
FLA: 5.0/2.6-2.5	Max 40°C Amb. 104°F	INS: B
SFA: 5.6/3-2.8	Time Cont. Rate: Duty	Baldor Motors
NEMA Eff: 55%	PF: 57%	

Motor Wiring Data (Grey Baldor Motor Only) (Motor is ASL Factory wired Lo Volt CW Rotation)

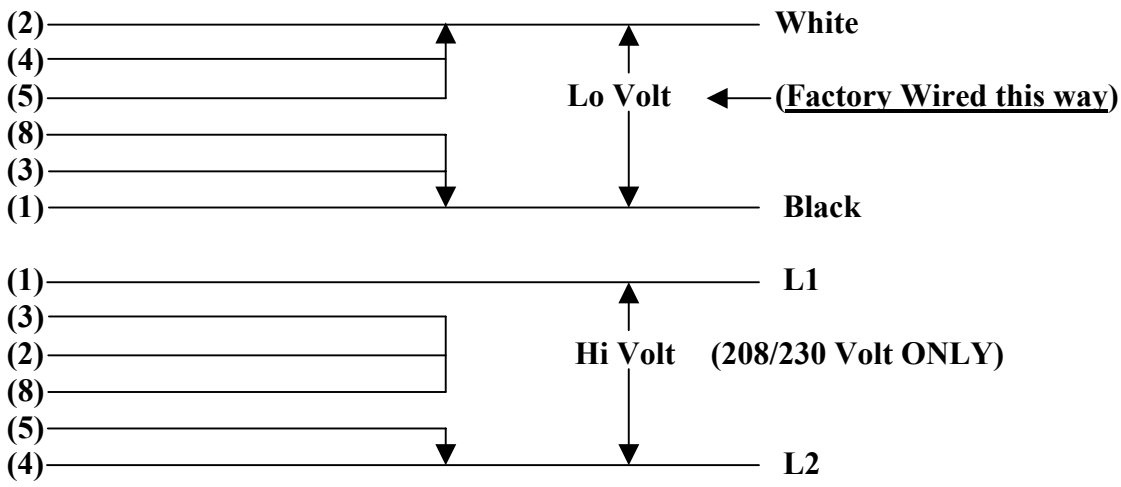

Do not reverse rotation!

The following pages contain the Installation and Service Instructions for the Tuthill L Series pumps. The model used in the ASL-FPRS-E40 Cabinet is 00LEV-040-CC-A. E-30 units use 30-LEV-CC-A-9821. The manual is reprinted with permission from the Tuthill Pump Group.



**TUTHILL
Pump Group**

12500 South Pulaski Road
Alsip, Illinois USA 60803
Tel 708 389-2500 Fax 708 388-0869
email: tuthillpump@tuthill.com
www.tuthill.com

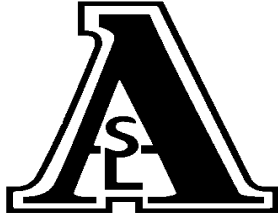

Installation and Service Instructions L Series Pumps

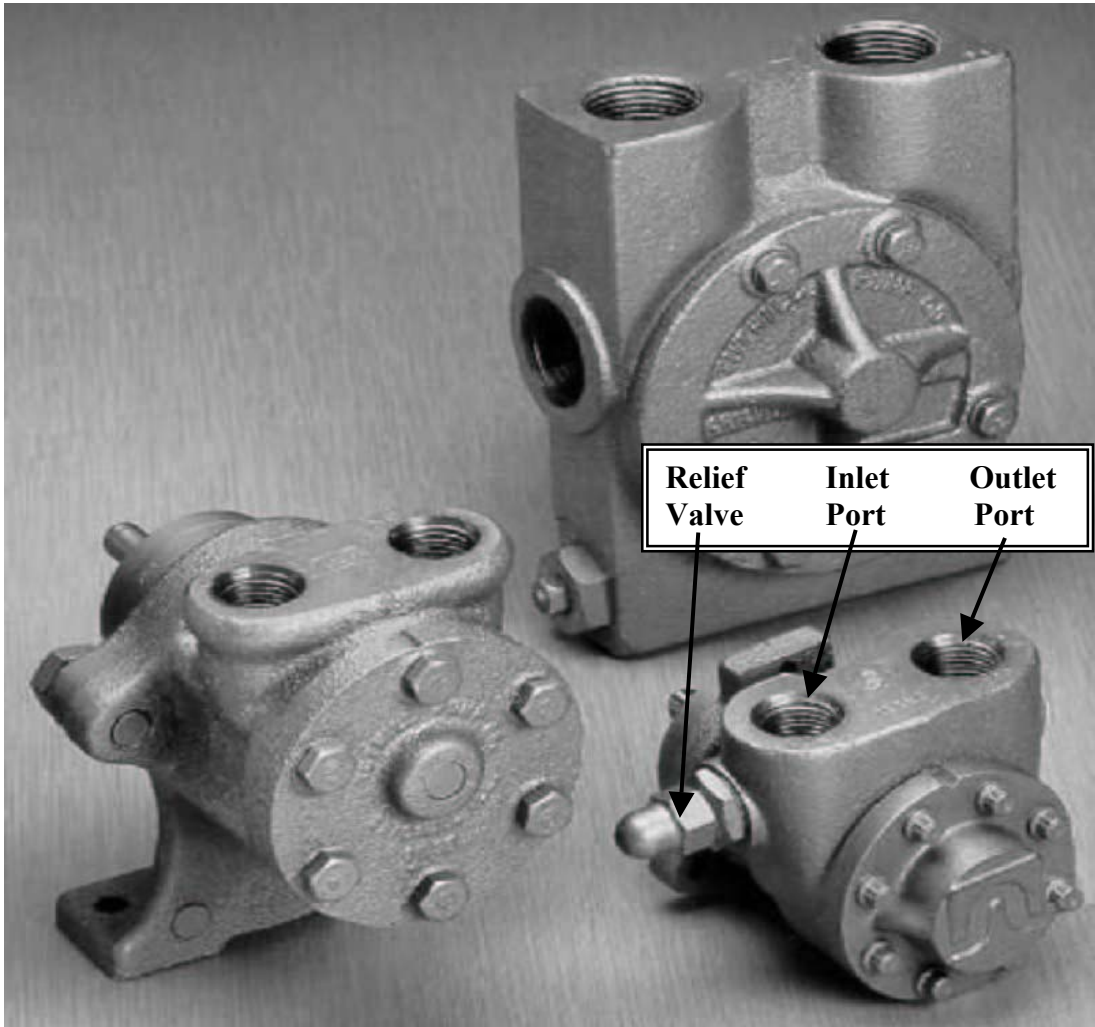

The pump used in ASL FPRS-E40-Cab is 00-LEV-040-CC-A
The pump used in ASL FPRS-E30-Cab is 30-LEV-CC-A-9821

General Description

Tuthill's LA and LE Series are compact, highly efficient, cast iron positive displacement rotary gear pumps with a mechanical seal. Built in six sizes, they provide nominal capacities from .5 to 14 gallons per minute and pressures up to 500 psi (300 psi in the 5LE). They are self priming and particularly suited to handle liquids of 35 to 1000 SSU viscosity. Higher viscosities can be handled at reduced speeds.

The LA Series is supplied with a two bolt flange, the **LE Series with a three bolt flange**. Optional mounting feet are available for both Series. **An internal relief valve is an option with the LE Series.** Both Series are bi-rotational (**unless outfitted with a relief valve**) and designed for direct drive at standard motor speeds, with modifications available for indirect drive.

The Pumping Principle

Tuthill's LA and LE Series employ the internal gear pumping principle. There are only two moving parts. Pumping action is based on a rotor, idler gear and crescent-shaped partition cast integral with the cover.

Power applied to the rotor is transmitted to the idler gear with which it meshes. The space between the outside diameter of the idler and the inside diameter of the rotor is sealed by the crescent.

As the pump starts, the teeth come out of mesh, increasing the volume. This creates a partial vacuum, drawing the liquid into the pump through the suction port.

The liquid fills the spaces between the teeth of the idler and the rotor and is carried past the crescent partition through the pressure side of the pump.

When the teeth mesh on the pressure side, the liquid is forced from the spaces and out through the discharge port.

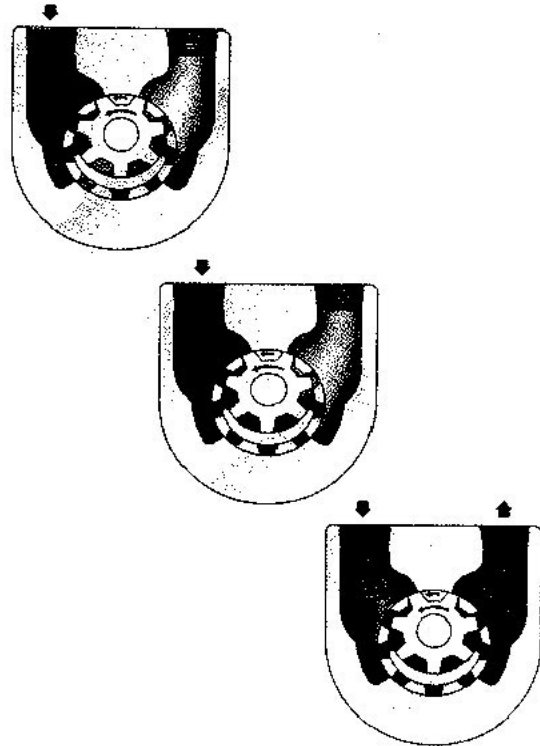



WARNING

Failure to follow these instructions could result in serious bodily injury or death.

These pumps should **not** be used for handling plain water, corrosive or abrasive liquids or liquids not possessing adequate lubricity.

Do not attempt to work on any Tuthill pump installation before completing the steps below.

Disconnect the drive so that it cannot be started while work is being performed.

Review the Material Safety Data Sheet (MSDS) applicable to the liquid being pumped to determine its characteristics and the precautions necessary to ensure safe handling.

Vent all pressure within the pump through the suction or discharge lines.

All Tuthill pumps contain residual 200 SSU lube oil from the factory production test. Determine if this is compatible with the fluid you are pumping. If the fluid is incompatible, consult the factory.

Location

LA and LE Series pumps are designed for working pressures up to 500 psi (300 psi in the 5LE) and are required to develop 25" mercury vacuum at 0 psi on factory test. While these pumps will develop as high as 27" of vacuum, it is a sound engineering practice to avoid extreme vacuum whenever possible. Select a pipe size to reduce line friction loss to a minimum.

The pump should be located as close to the source of supply as conditions permit and if possible, below the level of the liquid in the reservoir. When necessary to locate the pump in a pit, provisions should be made to safeguard against flooding. Care must be taken to properly support the suction and discharge piping so that no strain is put on the pump due to either weight or expansion. Piping strain can result in misalignment, hot bearings, worn couplings, and vibration. It is important that the piping used be clean and free of chips or scales.

Proper Installation

Unsatisfactory pump installations are usually characterized by poor suction conditions for the specific liquid being handled. Suction conditions should be minimized to prevent vaporization of the liquid. If vacuum conditions force the liquid to vaporize, cavitation will occur, resulting in loss of capacity, premature wear and noisy operation.

When handling high viscosity liquids, the speed of the pump must be reduced and the size of the lines increased to prevent cavitation.

Note: Pipe line friction increases at a rapid rate with an increase in viscosity. For a given pump and motor, larger pipe lines are necessary to maintain the same pump pressure when changing from a thin fluid to a thick one.

Most Tuthill LA and LE Series pumps are supplied with both ports on the same plane. Pumps with this type of porting arrangement should always be installed with both ports pointing upward to insure proper priming. If it is necessary to install the pump with the ports pointing to either side, it is recommended that the top port be the suction port. This will prevent gravity induced drainage of

ASL Technologies, LLC

10525 W US Hwy 30, Bldg. 3D, Wanatah, In. 46390

Phone 219.733.2777 or Toll Free 888-333.2990

E-Series Cabinet

Facsimile 219.733.2779 or e-mail custsvc@aslfilter.com

www.aslfilter.com

fluid through the suction port. When pipe lines are installed, an inverted "U" bend should be incorporated into the suction line close to the pump for priming purposes.

The multiple port arrangement in the 5LE offers flexibility but is limited to some common sense restrictions. There is an inlet and an outlet side to the pump. There must always be at least one pipe on each side. Units ordered with the side port option (modification S) are shipped with port plugs in the top ports. To adapt to a 90° porting arrangement, the plugs must be relocated. Because of its size, the 5LE will not mount onto a NEMA 48 frame motor unless the motor is shimmed approximately 1/4".

With the ports facing up, and viewing the pump from the shaft end, the inlet port is on the right for clockwise rotation and on the left for counter-clockwise rotation. Pumps with built in relief valves are directional. Therefore rotation must be specified at time of order. The adjusting screw of the internal relief valve must always be located on the suction side of the pump.

Pumps should be filled with oil at installation and should never be allowed to run dry.

Every pump installation should have a good foundation. Its structure should be sufficiently strong to hold the pump rigid and to absorb any strain or shock that may be encountered. The installation should be leveled, checked for proper piping alignment, and then fastened securely.

Method of Drive

Direct drive through a traditional flexible coupling is recommended. However, do not expect the flexible coupling to compensate for misalignment. Contact the coupling manufacturer to determine the maximum amount of misalignment to which the coupling can be subjected.

LA and LE Series pumps can be driven in either direction of rotation, unless outfitted with an internal relief valve. The seal chamber communicates with the neutral zone and therefore the seal is subjected to approximately one half of the discharge pressure.

All pump and motor units must be properly aligned during assembly and periodically checked since misalignment may occur later due to abuse or other conditions. Pipe strain can force the pump and motor shafts out of alignment. Therefore, all piping to the pump must be properly supported. Do not allow the pump to act as a pipe support.

Provide for proper expansion of pipes when handling hot liquids. Allow pump to reach operating temperature slowly. Rapid temperature change can result in damage to the cast iron components. Recheck the alignment.

Never align a pump and motor supplied with a pin type coupling without first removing the pins.

Never depend upon sight or feel. Use proper gauges when aligning the pump.

Never operate the pump without all guards in place.

Relief Valve Protection

The LA and LE Series are positive displacement pumps. As the pump rotates, liquid is positively delivered to the discharge side of the pump. If the discharge line is closed off, pressure will increase until the drive stalls and/or fails, the pump breaks or ruptures, or the piping bursts. To prevent this from happening, the use of a pressure relief valve is required. A relief valve that directs the flow back to the supply tank is recommended.

The internal relief valve available on LE Series pumps is designed for overpressure protection only. It is not intended as a flow control device or for any similar use. Continuous operation of the relief valve will result in excessive heat buildup within the pump cavity which could cause serious internal damage. Make certain the adjusting screw of the relief valve is located on the suction side of the pump.

Unless otherwise specified at the time of order, all LEV pumps are supplied with the standard spring, with a range of 55-120 psi (40-70 in the 5LE), set to provide full bypass relief at 55 psi.

Note that the ASL pump contains a special by-pass spring, which is factory set to provide full by-pass relief at 40 psi.

To adjust the relief setting within the range of a given spring's capability:

- Remove the acorn nut. (Not supplied with model 5LEV).
- Insert a screwdriver into the slot of the adjusting screw and hold it steady.
- Loosen the locking nut with a wrench by turning counterclockwise.
- Throttle the outlet line until the differential pressure at the pump port is at the desired level. If the pressure fails to reach this level with the throttling valve closed, turn the adjusting screw inward (clockwise) until the desired pressure is reached. (Adjusting clockwise raises the pressure setting).
- If the pressure reaches the desired level before the throttling valve is completely closed, turn the adjusting screw outward (counterclockwise) until the desired pressure is reached. (Adjusting counterclockwise lowers the pressure setting).
- Retighten the nut to lock the setting in place and replace the acorn nut.
- Recheck the pressure gauge reading.

If an internal relief valve has not been supplied with the pump some other means of protection must be utilized. These include in-line safety relief valves, pressure shutdown switches or other similar devices.

Strainer Protection

Strainers are used to remove contaminated particles from the fluid system and extend pump life. Every pump should be protected from these particles by a strainer in the suction line.

Strainer size and mesh of screen are determined by the rate of flow and viscosity of the fluid. Consult the strainer manufacturer for recommendations.

ASL Technologies, LLC

10525 W US Hwy 30, Bldg. 3D, Wanatah, In. 46390

Phone 219.733.2777 or Toll Free 888-333.2990

E-Series Cabinet

Facsimile 219.733.2779 or e-mail custsvc@aslfilter.com

www.aslfilter.com

Never use a strainer with a built-in automatic by-pass on the suction line set to open under 30" Hg. vacuum.

Install the strainer according to the designated direction of flow, locating it so that it is accessible for servicing. Use a duplex type strainer when shutdown during service is not possible.

Provide a vacuum gauge in the suction line for determining when the strainer requires cleaning.

Make certain strainer baskets are properly reinforced so as not to collapse under 30" Hg. vacuum.

WARNING

All Tuthill pumps contain residual 200 SSU lube oil from the factory production test. Determine if this is compatible with the fluid you are pumping. If the fluid is incompatible, consult the factory.

If the pump is to operate at elevated temperatures, it should be brought up to operating temperature gradually. Rapid or sudden introduction of liquid at an elevated temperature into the cold liquid chamber of the pump could cause damage to the seal or other internal parts.

Do not run the pump dry. This could cause severe damage to the seal, bushings and/or metal parts.

Startup

Prior to starting the pump double check the following:

- Pressure and vacuum gauges should be installed as close as possible to the pump.
- Rotate pump shaft to ensure it turns freely without binding.
- Recheck alignment and ensure all guards are in place.
- Make sure piping is independently supported and no strain is being transmitted to the pump.
- Make sure the safety relief valve is installed correctly.
- Check pump rotation.
- Open suction and discharge gate valves.
- Check for any leaks once gate valves are open.

After completing these checks the pump can be started.

CAUTION

The pump should not be run dry. If after approximately 60 seconds there is no discharge of liquid, stop the pump and investigate the possible cause. Failure to comply with this could cause severe damage to internal seals, bushings and/or metal parts.

Pump Performance Data

Size Capacity (gpm)

30L	.3
00L	.8
0L	1.6
1L	2.7
2L	4.9
5L	12.9

Note: 30LEV-CC-A-9821 @ 1725rpm = .5 gpm

Note: 00LEV-040-CC-A @ 1725rpm = .666 gpm

Based on pumping a fluid of 200 SSU viscosity at 100 psi and 1750 rpm.

WARNING

Failure to follow these instructions could result in serious bodily injury or death.

Do not attempt to work on any Tuthill pump installation before completing the steps below.

Disconnect the drive so that it cannot be started while work is being performed.

Review the Material Safety Data Sheet (MSDS) applicable to the liquid being pumped to determine its characteristics and the precautions necessary to ensure safe handling.

Vent all pressure within the pump through the suction or discharge lines.

All Tuthill pumps contain residual 200 SSU lube oil from the factory production test. Determine if this is compatible with the fluid you are pumping. If the fluid is incompatible, consult the factory.

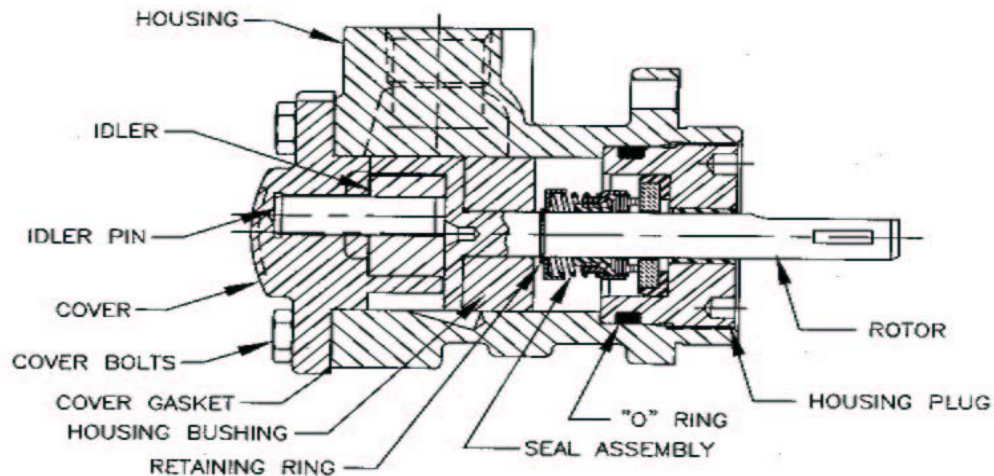

Disassembly of Seal

The seal assembly in LA and LE Series pumps can be changed without disassembly of the rest of the pump.

- Place the pump in a vise with the shaft facing up so that one jaw grips across the two ports. Do not tighten excessively as the pump housing may be distorted.
- Inspect the shaft at the keyway, flat or tang. Any burrs will interfere with removal of the housing plug and bearing assembly.
- Remove the housing plug with a spanner wrench, available from Tuthill as p/n 0L 506.
- Remove the seal from the shaft. The rubber boot will be bonded to the shaft, so it is necessary to push down on the seal to break this bond. Grasp the metal outer shell with any suitable device and pull the seal assembly upward. Remove the spring and washer.

ASL Technologies, LLC

10525 W US Hwy 30, Bldg. 3D, Wanatah, In. 46390

Phone 219.733.2777 or Toll Free 888-333.2990

E-Series Cabinet

Facsimile 219.733.2779 or e-mail custsvc@aslfilter.com

www.aslfilter.com

- Models 30LA through 1LA and models 30LE through 1LE have a snap ring on the shaft to back up the seal assembly. Do not remove this snap ring unless you are completely disassembling the pump. Models 2LA, 2LE and 5LE do not have a snap ring. A step on the shaft is used as the seal backup.
- Remove the stationary seal face from the housing plug by pressing out from the opposite side.
- If damaged, remove the O ring from the OD of the housing plug.

Disassembly of Pump

The seal assembly must be removed before the pump can be disassembled.

- Remove the snap ring from the shaft on all models except 2LA, 2LE and 5LE.
- Mark the cover and housing of the pump for proper re-assembly.
- Remove cover screws, cover, idler and rotor from the housing.

Inspection

Check the pump housing, rotor, idler gear, idler pin and cover for wear and chipped or broken teeth.

The housing bore and rotor OD may be checked for wear by positioning the rotor in the housing and checking for clearance in the bearing. The shaft must turn freely without any detectable side play.

Any side play will require replacement of the housing and/or rotor. If either of these two parts must be replaced, it is economically advisable to replace the entire pump.

Assembly of Pump

The following must be carefully followed when the pump is re-assembled:

- Clean all parts thoroughly using great care to eliminate all dirt.
- Install the rotor in the pump housing.
- Apply the gasket to the cover. Use a new gasket if the old one is damaged. (Models 30LA, 30LE and 5LE are also supplied with an O ring in the cover. Replace if damaged.)
- Place the idler gear on the pin in the cover assembly.
- Place the cover assembly with gear on the pump, aligning the matching marks for proper location.
- Install the cover screws. Tighten gradually, alternating from a screw on one side to a screw on the opposite side.
- Install the snap ring on the shaft (except models 2LA, 2LE and 5LE).

Assembly of Seal

- Clean all parts thoroughly using great care to eliminate all dirt.
- Oil the shaft with a suitable lubricating oil. (If the pump has an EPR seal, apply a silicon based lubricant instead.)
- Apply the appropriate lubricant to the inside of the new seal assembly.

For standard full length shafts with flat and/or keyway:

- Place seal assembly on the pump shaft.
- Push seal down with your fingers to a position approximately half way down the shaft.

For modification "A" tang shafts: The ASL Pump is a Mod. "A" shaft

- Use tapered plastic sleeve, available from Tuthill as part number 1LPF 531 7010.
- Lubricate the sleeve.
- Place seal assembly on the sleeve. The tapered end of the sleeve fits into the spring end of the seal assembly.
- Place the slotted end of the sleeve on a bench. Press down on the carbon face of the seal with your fingers and slide the seal to about the midpoint on the sleeve.
- Place the slotted end of the sleeve over the tang on the pump shaft. Line up the outside diameters of the sleeve and shaft by eye.
- Push seal down with your fingers so that it passes from the sleeve to a position approximately halfway down the shaft.
- Press the stationary face into the housing plug. The lapped surface must be up. Protect this lapped surface by covering it with a piece of paper when pressing down on the face. Use your fingers for this operation.
- Place a new O ring on the OD of the housing plug, if required, and lubricate.
- Lubricate the carbon face liberally.
- Re-assemble the housing plug into position over the pump shaft. Do not nick the seal face by hitting the pump shaft. Tighten the housing plug with the spanner wrench. The seal will automatically be positioned by this operation.
- If the pump is equipped with a ball bearing (modification K), press the bearing onto the shaft. Do not hammer into position or press on the bearing outer race.
- Check pump for free rotation by turning the shaft with a suitable wrench. There will be a definite resistance to turning because of the seal load. The pump must turn freely without binding.

Changing Rotation

LA and LE Series pumps are bi-directional and will work equally well in either direction with no modification. However, if outfitted with an internal relief valve (model LEV), these pumps become rotational. Rotation cannot be changed in the field unless the housing is replaced.

(Do Not change rotation on an ASL Filtration System Pump)

To change the location of the suction port on a pump outfitted with Tuthill's unique automatic reversing feature (models RLA and RLE):

- Remove the cover screws.
- Rotate the cover 180° so that the boss on the cover points to the new suction (inlet) port.
- Align the mounting holes and reinstall the cover screws.

Note: Location of the suction port cannot be changed in the field on RLEV pumps unless the housing is replaced.

Troubleshooting

No fluid is delivered.

- Power is not on.
- Net positive suction head available (NPSHA) is lower than required for the inlet conditions and the vapor pressure of the liquid pumped. Calculate NPSHA and redesign piping if necessary.
- Leaks in suction line or port passages. These can be detected by submerging the pressure line from the discharge side of the pump into a pail of liquid where the air will be seen in the form of bubbles.
- Direction of shaft rotation is incorrect.
- Pump shaft is not rotating. The coupling is defective or the tongue and groove are not engaged.
- The relief valve setting is too low. Liquid is discharging through the by-pass port. **On ASL Filtration Systems, the by-pass should be set so the pump enters "full bypass" at 40 psi maximum.**

Capacity is too low.

- There are air leaks in the suction line.
- Suction losses are too high. The suction lift is too great or the suction line too small or too long. This can be detected by installing a vacuum gauge directly at the pump suction. The maximum vacuum at the pump suction should never exceed 15" of mercury. Vaporization caused by higher vacuums will generally result in capacity drop off. Suction conditions must be redesigned.
- Pump speed is too slow.
- The strainer is too small or obstructed.
- The suction port or pipe is not immersed deeply enough in the liquid.
- Piping is improperly installed, permitting an air pocket to form in the pump.
- Increased clearances or wear in the pump will sometimes cause the pump to deliver an insufficient supply of fluid. This can generally be corrected by reducing the thickness of the cover gaskets. A folded gasket or a slight amount of dirt can exaggerate the problem and cause leakage.

ASL Technologies, LLC

10525 W US Hwy 30, Bldg. 3D, Wanatah, In. 46390

Phone 219.733.2777 or Toll Free 888-333.2990

E-Series Cabinet

Facsimile 219.733.2779 or e-mail custsvc@aslfilter.com

www.aslfilter.com

Pump works spasmodically.

- Leaky suction line.
- Varying suction conditions.
- Air or vapor in the fluid.

Excessive power draw.

- Pressure too high.
- Liquid is more viscous than originally expected.
- Suction or discharge lines obstructed.
- Insufficient horsepower.
- Drive shaft and pump misaligned.
- Pump binding due to insufficient end clearance.
- Pump shaft is bent.
- Misalignment within the pump due to bad piping or poor installation, causing strain or distortion.

Pump is noisy.

- Pump is cavitating due to inadequate suction conditions.
- Misalignment of coupling.
- Coupling is set too close to pump.
- Vibration of pump due to worn or bent shaft.
- Air leaks on suction side of pump or air entrainment in the fluid.

Pump leaks.

- Cover bolts need tightening or cover gasket is defective.
- Worn or defective seal.

Material Returns

If it becomes necessary to return a pump to the factory, a Return Goods Authorization (RGA) must be obtained from either your local Authorized Distributor or our Chicago plant. No RGA can be issued until a completed Material Safety Data Sheet (MSDS) has been forwarded to our Chicago plant and return of the pump approved.

- Tuthill pumps are precision built and must be handled with care.
- Pumps must be drained of all fluid and the ports plugged to prevent foreign material from getting into the pump.
- Pumps must be packaged securely to prevent damage while in transit.

Contact ASL Technologies for return of Defective pumps installed in ASL Filtration Systems

-END OF SERVICE MANUAL-