

Horizontal Multistage Pump



Applications

- ▶ Mineral processing
- ▶ Fire-fighting systems
- ▶ Water supply systems
- ▶ Water systems for industrial uses
- ▶ Warm water heating, chilled & cooling water systems

Features & Benefits

The D Series horizontal multistage pump is a sectional design, thus having each diffuser built into the sectional interstage casing, which comprehensively, with an impeller, being affixed on the shaft, forms one stage. Position of a suction flange can be directed vertically upwards; horizontally left or right.

Operation Data

Pump Size	DN 40 up to 300 mm
Capacities	up to 200 l/s
Heads	up to 900 Meter
Speed	1450 - 2900 rpm
Motor Rating	up to 2500 kW
Operating Temperature	up to 120°C*

* The materials of pumps differ according to the type of medium, operating temperature and pressure.

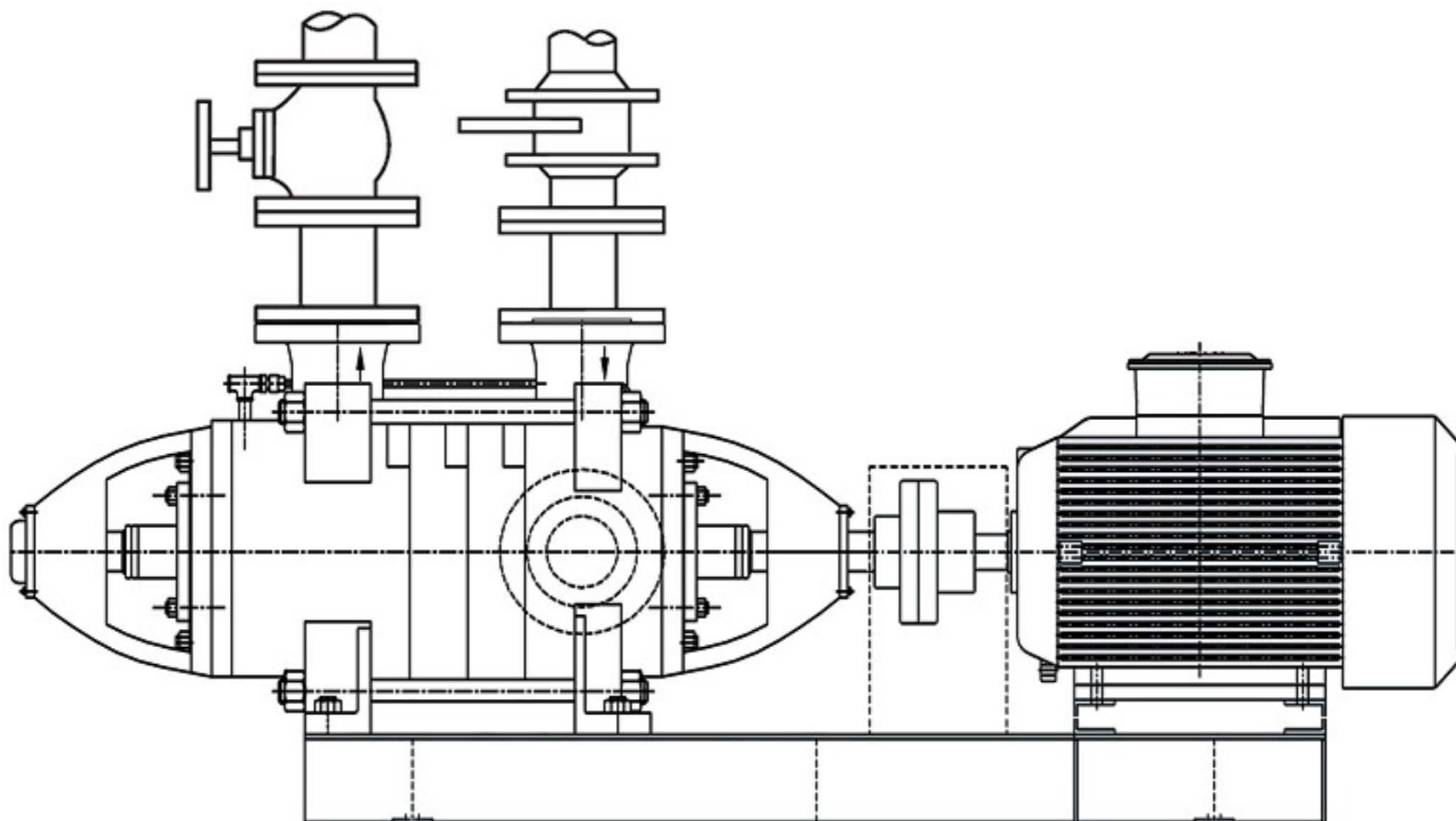

Performance Range

