

Vertical Inline Pump



Features & Benefits

SIL vertical single in-line pumps are designed for a straight inlet and outlet pipework and thus ensures easier installation with lower cost. The top pull-out design can make the service and maintenance work easier without dismantling the pump housing from the pipelines.

Applications

- ▶ Fire-fighting systems
- ▶ Water supply systems
- ▶ Industrial circulating systems
- ▶ Water systems for industrial uses
- ▶ Warm water heating, chilled & cooling water systems

Operation Data

Pump Size	DN 32 up to 250 mm
Capacities	up to 200 l/s
Heads	up to 90 Meter
Speed	1450 - 2900 rpm
Motor Rating	up to 110 kW
Operating Temperature	up to 105°C*

* The materials of pumps differ according to the type of pumped liquid, operating temperature and pressure.

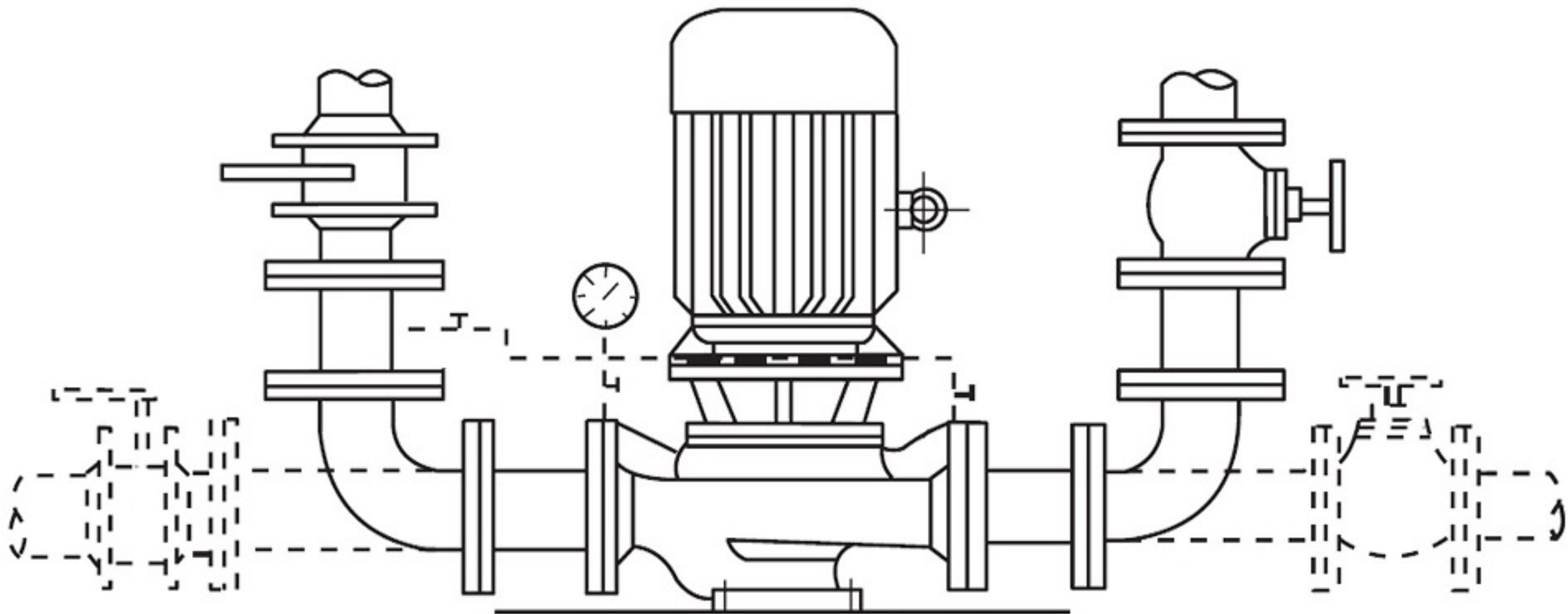

Performance Range

