

Vertical Inline Pump



Applications

- ▶ Water supply systems
- ▶ Industrial circulating systems
- ▶ Chilled & Cooling water systems
- ▶ Water systems for industrial uses

Features & Benefits

BGI vertical in-line pumps are designed for a straight inlet and outlet pipework and thus ensures easier installation with lower cost. The top pull-out design can make the service and maintenance work easier without dismantling the pump housing from the pipelines.

Operation Data

Pump Size	DN 32 up to 100 mm
Capacities	up to 1500 l/m
Heads	up to 29 Meter
Speed	2900 rpm
Motor Rating	up to 7.5 kW
Operating Temperature	up to 40°C*

* The materials of pumps differ according to the type of pumped liquid, operating temperature and pressure.

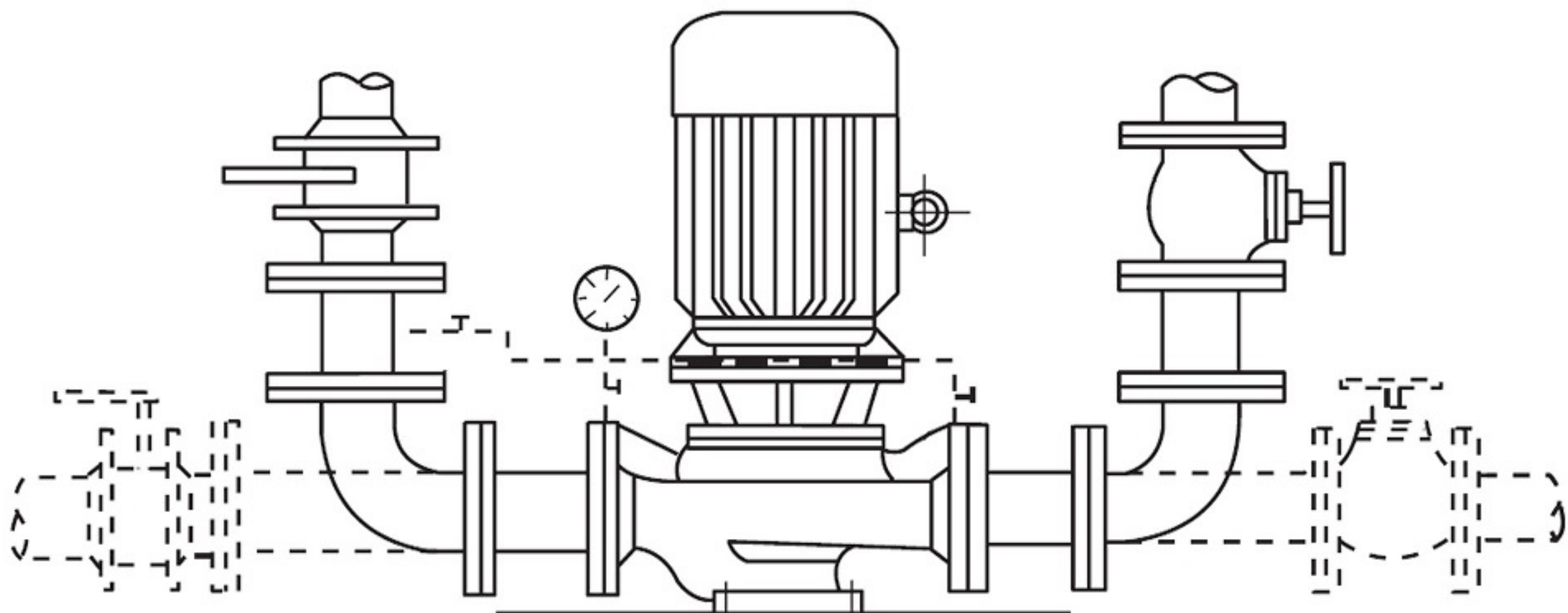

Performance Range

