

Measurement of WEIGHT, FORCE, PRESSURE, TORQUE, DISPLACEMENT and TEMPERATURE

RISOLUZIONE STANDARD
± 100000 div
RESOLUTION STANDARD

ACCURATEZZA
≤ ± 0.005%
ACCURACY

15
Stabilità a lungo termine
Long term high stability

Alta Affidabilità
High Reliability

CE RoHS

USB 2.0

Smart

Data Logger

"THE EVOLUTION OF THE SPECIES" : after more than 20 years of service in the various versions the new **MP6Plus** is born.

MP6Plus is a Professional Digital Laboratory Indicator with **1, 2, 3, or 4 inputs**, suitable for receiving signals from strain gauge sensors, transmitters with voltage or current output and PT100. Particularly suitable for both static and dynamic applications, for calibration and verification in metrology laboratories or industrial environments where it is necessary to make measurements of weight, force, pressure, torque, displacement and temperature in a synchronized manner.

To **FIT EVERY APPLICATION** the instrument can be configured and customized: the function keys F1, F2, F3 and F4 can be programmed for the function of interest such as: PEAK, HOLD, RELEASE, TX DATA DATALOG, DISCHARGE, ZOOM.

MP6Plus allows you to enable and disable each channel and using the **ZOOM** function it is possible to display only the channel of interest in full screen.

The instrument works with a resolution of ± 100.000 divisions and an accuracy better than 0.005% due to an internal 24-bit Sigma-Delta AD converter and a measurement control that is carried out for switching at a frequency equal to that of sampling: this system provides a better suppression of interference due to offset drift and to the connecting cables.

The sampling frequency (common to all channels) can be set from 2.5 samples per second up to 4800 samples per second therefore the instrument meets the needs of applications that require a considerable speed of response.

Each input channels can be supplied in 4 different configurations:

- Version with **input for strain gauge transducers** with standard resolution of ± 100.000 div. suitable for working with load cells or force transducers with output $\pm 2\text{mV/V}$ or $\pm 3\text{mV/V}$ and 4 wires or 6 wires connection.
- Version with **voltage input** with standard resolution of ± 100.000 div. suitable for working with pressure, torque transmitters, etc ... with output $\pm 10\text{V}$ or $\pm 5\text{V}$.
- Version with **current input** with a standard resolution of ± 160.000 div. suitable for working with pressure, torque transmitters, etc ... with output 4-20mA or 0-20mA and 2- and 3-wires.
- Version with **temperature input** for PT100 eligible to work in the range from $-50\text{ }^{\circ}\text{C}$ to $+250\text{ }^{\circ}\text{C}$ with $0.1\text{ }^{\circ}\text{C}$ resolution and accuracy $\pm 1\text{ }^{\circ}\text{C}$.

The instrument is equipped with a rear **USB** port to connect directly to a PC or Tablet.

As **OPTIONS** the instrument can be equipped with:

- **Additional input channels CH2, CH3 and CH4** with a synchronization system that allows to acquire at the same instant the measurement of all channels.

- One, two, three or four **Analog Outputs** programmable as voltage ($\pm 10V$, 0/5V, 0/10V, $\pm 5V$) or current (4-20mA, 0-20mA, 0-24mA) that can be associated to different channels or to the TOTAL (sum of two or more channels). The refresh rate of the analog signals is equal to the frequency of acquisition of the respective channels in input.
- A serial **RS232** line to directly connect the device to a PC, PLC or a serial **PRINTER**.
- 4 programmable **DIGITAL INPUTS** 24Vdc.
- A serial **RS485** line with protocol MODBUS RTU normally used to connect multiple instruments in a same network to a PLC.
- **WIRELESS** transmission designed to transmit measurements to other devices by radio at a distance up to 100m.
- A powerful **DATALOGGER** with non-volatile memory, which allows to store data at the maximum acquisition speed, synchronize recordings with an internal clock-calendar and eventually export data to a file using an USB stick in .csv file format that can be transferred directly to Microsoft Excel.

Other features and functions of importance are:

- Graphical, large and high resolution LCD display with backlit.
- Automatic **UNIT CONVERSIONS** in many specific units for each type of transducers.
- Function **MULTIMETER** which displays the signal of the sensor directly in mV/V, V or mA.
- User selectable language : **ITALIAN or ENGLISH**.
- Function **ZERO** and **AUTOZERO** to reset automatically the measure if the measurement is below a set threshold.
- Function of **HOLD**, **PEAK**, programmable **FILTER**.
- Function of **DISCHARGE** in order to measure the amount of product discharged for example from a tank.
- Function **TOTAL** to perform the sum of the channels.
- Function **KEY LOCK** to protect the instrument settings by unauthorized persons.
- Function **CLOCK-CALENDAR** (Option) with date and time.
- 24 columns **PRINTER** (option) connected to the serial port through which it is possible to print the measuring points with the date and time and the data of the company that carried out the survey.

For each input channel, you can calibrate the signal coming from the sensor both in the **POSITIVE RANGE** and in the **NEGATIVE RANGE** (Example in tension and compression) through 3 different modes:

- Calibration with **Full Scale**: characterization through the programming of the transducer full scale and sensitivity in both the positive and negative range.
- Calibration for **POINTS**: linearity correction by programming 5 known points in both the positive and negative range.
- **Known Weight**: practice characterization (in the field) by imposing a known weight, pressure, torque to the sensor and calibrating the transducer output to this reference value.



To increase security the instrument has the ability to perform a **BACKUP** of all calibrations data so that you can recall them in case of accidental tampering.

MP6^{Plus} may be accompanied by various applications and analysis software to perform calibrations for : PRESSURE FORCE and TORQUE measurements.









Typical applications:

Calibration of reference machines: force, pressure and torque.
 Calibration of materials testing machines.
 Calibration of test benches and testing machine.
 Calibration of transducers, pressure transmitters and pressure switches.
 Calibration of load cells, force transducers and dynamometers.
 Calibration of wrenches: snap or direct reading, screwdrivers.
 Audits between laboratories for the verification of measurement uncertainties.
 Audit to perform metrological confirmations.
 Audit for interlaboratory comparisons.
 Quality control in production lines.
 Quality Control in Calibration and Testing Laboratories.
 Tests on materials such as springs, friction detection, breakout forces.
 Tests on protective devices and safety.
 Monitoring over time of mechanical quantities.

STANDARD CONFIGURATION

INPUT	<p>CH1 $\pm 2\text{mV/V}$, $\pm 3\text{mV/V}$ $\pm 5\text{V}$, $\pm 10\text{V}$ $0\text{-}20\text{mA}$, $4\text{-}20\text{mA}$</p>		
FUNCTION	<p>POWER SUPPLY 220 Vac</p>	 USB 2.0 	<p>PEAK TOTAL DISCHARGE DIGITAL FILTER ZERO and AUTOZERO DIGITAL CALIBRATIONS UNIT CONVERSION</p>



ADDITIONAL OPTIONS

INPUT	<p>CH2 - CH3 - CH4 OPTIONS $\pm 2\text{mV/V}$, $\pm 3\text{mV/V}$ $\pm 5\text{V}$, $\pm 10\text{V}$ $0\text{-}20\text{mA}$, $4\text{-}20\text{mA}$ PT100 (temperature) ONLY CHANNELS CH2 and CH4</p>			
OPTION	<p>RS232C RS485 MODBUS</p>  <p>PRINTER</p> 	<p>From 1 to 4 ANALOG OUTPUTS Associated with channels CH1, CH2, CH3, CH4 or TOTAL The refresh rate of the analog signals is equal to the frequency of acquisition of the respective channels in input.</p> 	<p>4 Programmable Digital Inputs</p>  <p>Used for:</p> <ul style="list-style-type: none"> • Remote Function key • PLC Commands 	<p style="text-align: center;"> DATA TRANSMISSION</p> 
OPTION	<p style="text-align: center;"> Data Logger</p> <p style="text-align: center;">+ Internal CLOCK CALENDAR</p>	 <p>Front panel USB port to download data logger using a USB sticks and to bring data directly to a PC. File type : csv or txt</p>	<p style="text-align: center;">Power Supply 115 Vac 24Vdc</p>	 <p style="text-align: center;">HANDLE</p>

TECHNICAL DATA

STANDARD NUMBER OF CHANNELS	1 (CH1)
ACCURACY	≤± 0,005%
LINEARITY ERROR	≤± 0,005%
INTERNAL DIVISIONS	24bit
CH1 INPUT : STRAIN GAUGE TRANSDUCERS	± 2mV/V, ±3mV/V (max ±3.5mV/V)
RESOLUTION	± 100.000div
TRANSDUCERS POWER SUPPLY	5Vdc switching (±3%)
TYPE OF CONNECTION	4 or 6 wires
TRANSDUCER RESISTANCE	from 100Ω to 2000Ω
CH1 INPUT : VOLTAGE AMPLIFIED TRANSDUCERS	± 10V and ± 5V
RESOLUTION	± 100.000div
TRANSDUCERS POWER SUPPLY	20Vdc (±1Vdc)
CH1 INPUT : CURRENT AMPLIFIED TRANSDUCERS	0-20mA 4-20mA
RESOLUTION	+200.000div +160.000div
TRANSDUCERS POWER SUPPLY	20Vdc (±1Vdc)
Unit Conversions for WEIGHT and FORCE	kg, t, N, daN, kN, MN, lb, klb
Unit Conversions for PRESSURE	bar, mbar, psi, MPa, kPa, Pa, mH ₂ O inH ₂ O kg/cm ² , mmHg, cmHg, inHg, atm
Unit Conversions for TORQUE	N·m, N·mm, kN·m, kg·m, g·cm, kg·mm, ft·lbf, in·lbf
Unit Conversions for DISPLACEMENT	mm, m, foot, inch, cm, dm, μm
MULTIMETER FUNCTION	Direct Display in mV/V, Volt o mA
BACKLIT GRAPHIC DISPLAY CHARACTER SIZE	128 x 64 dots ~ 13 mm
TRANSDUCER CALIBRATION	Both in the POSITIVE and NEGATIVE range
TYPE OF DIGITAL CALIBRATION	Full Scale, Point Interpolation, Known Weight
FIELD LINEARITATION	On 1 ... 5 measurement point
BACKUP AND RESTORE FUNCTION	Save and restore all configuration data
FUNCTION OF ZERO	100% (on all the measurement range)
FUNCTION OF AUTOZERO	With TIME and THRESHOLD programming
FUNCTION OF PEAK	POSITIVE and NEGATIVE
FUNCTION OF DISCHARGE	YES
FUNCTION OF KEY BLOCK	Enabled through a Password
FUNCTION OF TOTAL (on all enabled channels)	YES
PROGRAMMABLE RESOLUTION	1 ... 100
DIGITAL FILTER	0 ... 5
PROGRAMMABLE CONVERSION RATE	from 2.5 to 4800 samples for second
INSTRUMENT LANGUAGE	ITALIAN and ENGLISH
Function Keys programmable in configuration	F1 – F2 – F3 – F4
Rear USB output, Connector type B	Max Cable Length 3.5m
NOMINAL WORKING TEMPERATURE	0... +50°C
MAX WORKING TEMPERATURE	0... +50°C
STORAGE TEMPERATURE	-20... +70°C
TEMPERATURE EFFECTS on the measurements a) on zero (10°C variation)	≤±0,005%
b) on full scale (10°C variation)	≤±0,005%
POWER SUPPLY	230 Vac +/-10%
FREQUENCY	50/60 Hz
EXTERNAL PROTECTION FUSE	250mA / 250 V
MAX. POWER REQUIRED	10VA
CASE MATERIAL	ALUMINIUM painted container
PROTECTION CLASS (EN 60529)	IP40
DEGREE OF ENVIRONMENTAL CONT.	1
WEIGHT	~ 0,8 kg

OPTIONS

INPUT CH2-CH3-CH4: STRAIN GAUGE TRANSDUCERS RESOLUTION TRANSDUCERS POWER SUPPLY TYPE OF CONNECTION TRANSDUCER RESISTANCE	$\pm 2\text{mV/V}$, $\pm 3\text{mV/V}$ (max $\pm 3.5\text{mV/V}$) $\pm 100.000\text{div}$ 5Vdc switching ($\pm 3\%$) 4 or 6 wires from 100Ω to 2000Ω									
INPUT CH2 – CH3 - CH4: VOLTAGE AMPLIFIED TRANSDUCERS RESOLUTION TRANSDUCERS POWER SUPPLY	$\pm 10\text{V}$ e $\pm 5\text{V}$ $\pm 100.000\text{div}$ 20Vdc									
INPUT CH2 – CH3 - CH4: CURRENT AMPLIFIED TRANSDUCERS RESOLUTION TRANSDUCERS POWER SUPPLY	<table style="border: none;"> <tr> <td style="border: none;">0-20mA</td> <td style="border: none;"> </td> <td style="border: none;">4-20mA</td> </tr> <tr> <td style="border: none;">+200.000 div</td> <td style="border: none;"> </td> <td style="border: none;">+160.000 div</td> </tr> <tr> <td colspan="3" style="border: none; text-align: right;">20Vdc</td> </tr> </table>	0-20mA		4-20mA	+200.000 div		+160.000 div	20Vdc		
0-20mA		4-20mA								
+200.000 div		+160.000 div								
20Vdc										
INPUT CH2 – CH4 TEMPERATURE ACCURACY RESOLUTION UNITS	PT100 2 wires (range -50 $+250^{\circ}\text{C}$) $\pm 1^{\circ}\text{C}$ $\pm 0.1^{\circ}\text{C}$ $^{\circ}\text{C}$, $^{\circ}\text{F}$									
RS232 SERIAL OUTPUT RS485 MODBUS RTU (max 32 in multipoint) PRINTER	MAX cable Lenght 13m MAX cable Lenght 1000m 24 columns (RS232)									
<div style="display: flex; align-items: flex-start;"> <div style="flex: 1;">  </div> <div style="flex: 2; padding-left: 10px;"> <p>USB Port for PC communication.</p> <p>RS232C serial port for PC or PLC communication.</p> <p>RS485 serial port for PC or PLC communication</p> <p>The USB, RS232 and RS485 are independent so it is possible to connect at the same time a PC , a PLC and a 24 columns serial printer.</p> <p>Serial communication with a 24 columns PRINTER .</p> <p>On the report is it possible to print up to 3 header lines with the company data. A measurement point will be printed by pressing the key PRINT or using a remote digital command.</p> <p>You can print on both paper and adhesive labels.</p> </div> </div>										
Analog Outputs Current Output Voltage Output (max 20mA – RL min: 1k Ω)	1, 2, 3 or 4 independent outputs 0-20mA, 4-20mA, 0-24mA 0-5V, 0-10V, $\pm 10\text{V}$, $\pm 5\text{V}$									
DIGITAL INPUTS with programmable function	4									
WIRELESS transmission – only version with up to 2 channels Max distance in free space	433MHz 100m									
<p>DATA LOGGER allows you to store the measurements and to keep them in internal memory even if you turn off the instrument.</p> <p>The logging can be done in AUTO mode or MANUAL mode.</p> <p>The AUTO mode records the measurements at regular intervals for a programmable time. The time interval between two measurements points can be varied from the maximum speed conversone (4,8kHz) up to recording every 24 hours.</p> <p>The MANUAL mode allows the operator to decide when to record the measurements on memory. The command can be given either via a button on the front panel or via a digital input.</p> <p>All data can be subsequently displayed on the display, downloaded through the powerful software MPSupervisor or exported to external Flash Memory (USB stick) for charting, data processing on Microsoft Excel, press reports etc ...</p>										
DATA LOGGER Max Storing Points	1 channel enabled : max. 130.000 2 channels enabled: max. 65.000 3 channels enabled: max. 32.000 4 channels enabled: max. 43.000 4 channels enabled +TOTAL: max. 26.000									
MAX PROGRAMMABLE TIME CLOCK - CALENDAR	100 days Year, Month, Day, Hour, Minute,Seconds									
<div style="display: flex; align-items: flex-start;"> <div style="flex: 1;">  </div> <div style="flex: 2; padding-left: 10px;"> <p>Front Panel USB connector (type A) that allows you to save or export the recorded measurements directly on a USB stick, for faster portability of the measures on PC.</p> <p>It is possible to export the file in TXT or CSV for a direct import of the measures on programs such as Microsoft Excel.</p> </div> </div>										
POWER SUPPLY	115 Vac or 24Vdc									

COMPONENTS SUPPLIED



Power Cord



DB9 Male Connector for transducer



CD with Manual and USB Driver

COMPONENTS IN OPTION (purchased separately)



USB cable



RS232 Serial Cable



Pair of mounting brackets for panel



Desktop Printer 24 columns



DB9 Male Connector For each transducers



Calibration Report ACCREDIA Certificate (MP6Plus +Transducer)



Calibrator for mV/V signals



Case for transport

ELECTRICAL CONNECTION



- ❶ Power Supply
- ❷ Fuse
- ❸ Main Switch
- ❹ USB Port
- ❺ RS232 - RS485 - Digital Input – Analog Outputs.
- ❻ CH1 standard input
- ❼ CH2 Input (Option)
- ❽ CH3 Input (Option)
- ❾ CH4 Input (Option)

APPLICAZIONI SOFTWARE (purchased separately)

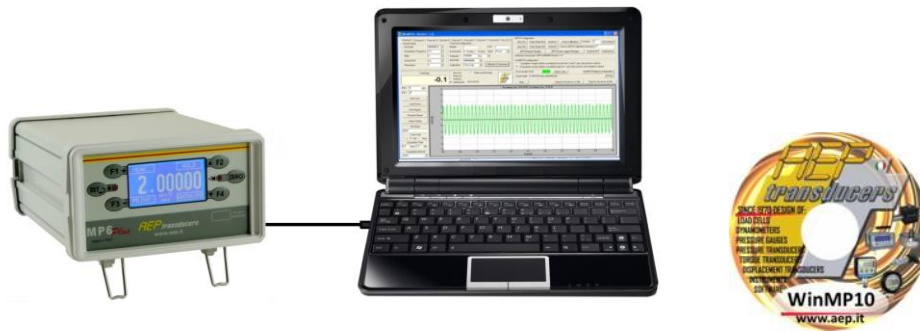

To complete the system of measurement **AEP transducers** has developed several software applications that interface directly to the instrument **MP6Plus** and support the user in the various functions of calibration, testing, analysis, data storage, transfer of measures on Microsoft Excel etc. ...

MPSupervisor is a software dedicated to **MP6Plus**. Through this software you can download the data logger and operate directly on **MP6Plus** to change parameters and create graphics test.

Quick Analyzer is a general purpose acquisition software where **MP6Plus** can be associated to other **AEP instruments**. For dedicated calibration applications 3 different software are available: **ForceKal**, **PressKal**, **TorqueKal**.

For more information download the manuals of the software on the site:

www.aeptransducers.com

www.aep.it

ForceKAL

Dedicated to the calibration of testing machines, test benches where force is generated.

Sample devices

Type	Serial n°	Certificate n°	
MP6A	06375	07004F	
Type	Serial n°	Max range	Unit
TCE	101001	350	kN
Baud rate	COM	Decimal	
9600	5	0000.00	
mV/V			

Open COM Close COM

Receiving data and remote commands

Sample Force
349.99
kN

Resolution: 1, 2, 5, 10
Measure Unit: [][][]
Zero: On, Off
Peak: On, Off

Calibration chart

Applied load kN	Cycle 1 kN	Cycle 2 kN	Cycle 3 kN	Average kN	Reading error %	Expanded uncertainty %
0.00	0.00	0.00		0.000	-	-
70.00	70.00	70.01		70.005	0.044	0.088
140.00	140.01	140.01		140.010	0.025	0.050
210.00	210.03	210.02		210.025	0.019	0.038
280.00	280.03	280.03		280.030	0.013	0.026
350.00	350.04	350.04		350.040	0.011	0.022

Machinery in Calibration

Type	Object	
TMM350	Test Material Machine	
Manufacturer	Serial number	
ABC	MM350-0010	
Max range	Unit	Resolution
350	kN	0.1

Calibration Certificate: CTF0004

Calibration characteristics

measurement points: 5
measurement cycles: Two cycles
measurement type: Compression

Calculate Errors: Calculate

Start Accepts the measurement

PressKAL

Dedicated to the calibration of pressure gauges such as

- manometers
- pressure transducers
- pressure transmitters
- pressure switches

TORQUEKAL

Dedicated to the calibration of torque wrench with direct reading or snap.

QUICK ANALYZER

Dedicated to recording and graphical analysis of up to 16 different AEP transducers instruments to measure: force, weight, pressure, torque and displacement.

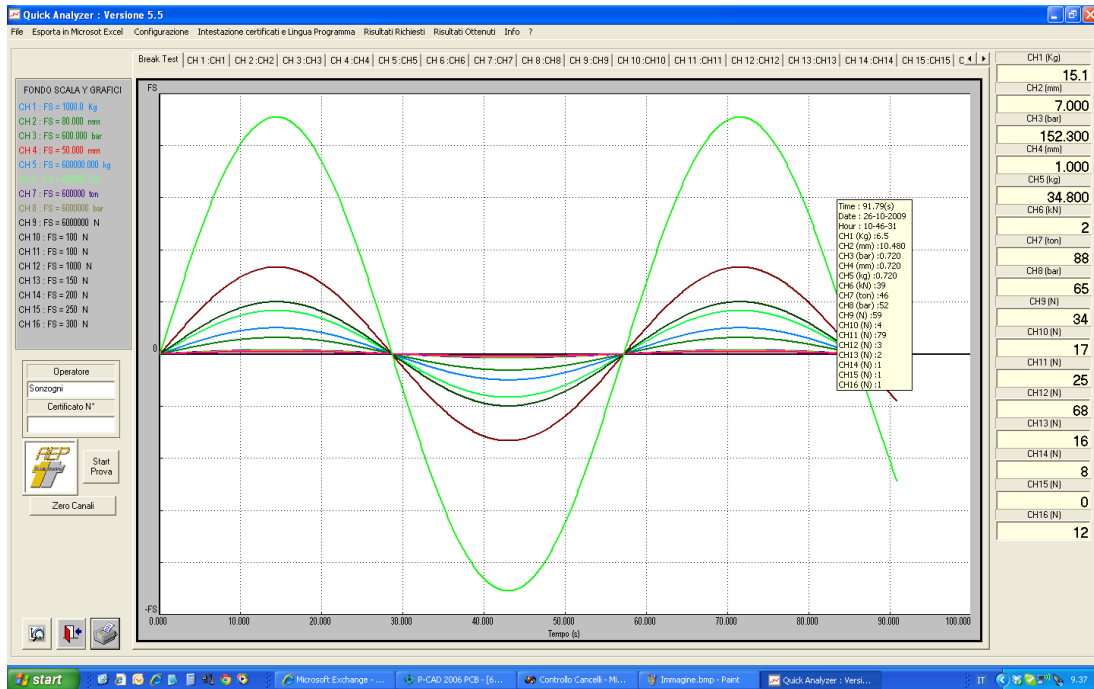

MP Supervisor

A dedicated program that allows an immediate interfacing through the USB port with the MP6Plus and allows you to view graphs, export data to Microsoft Excel directly from the PC and set all configuration parameters. The program also allows you to download a Data Logger carried out using the internal memory or the USB Flash Memory and display the respective curves of acquisition.

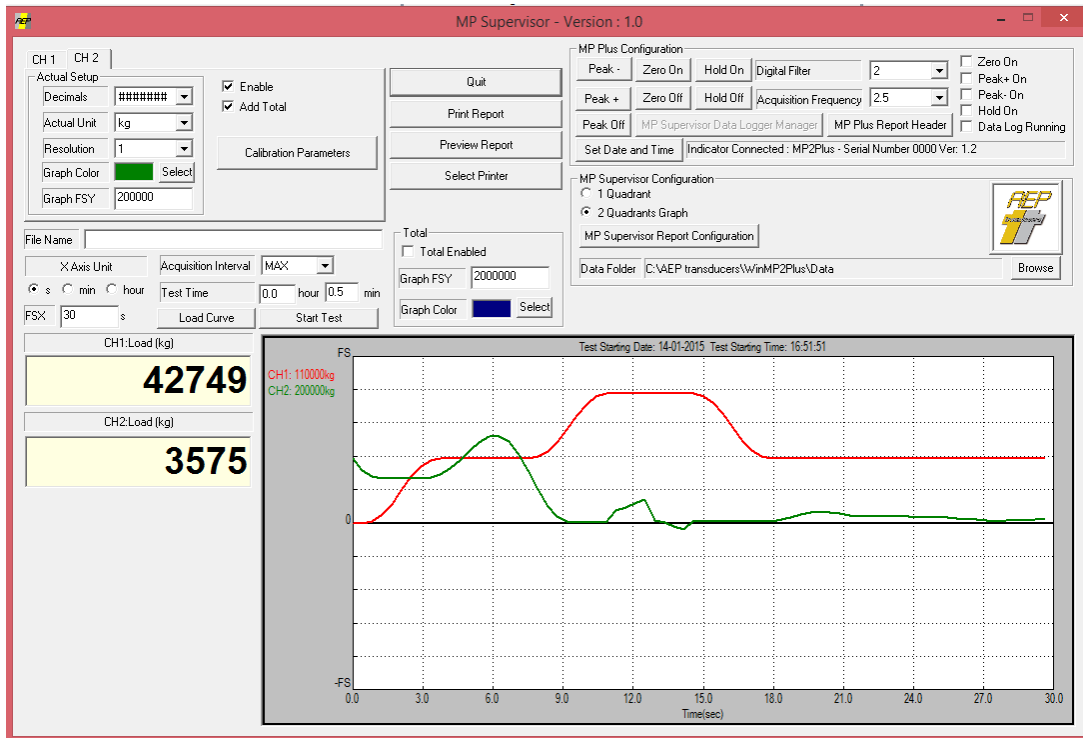

Dimensions (mm) STANDARD VERSION

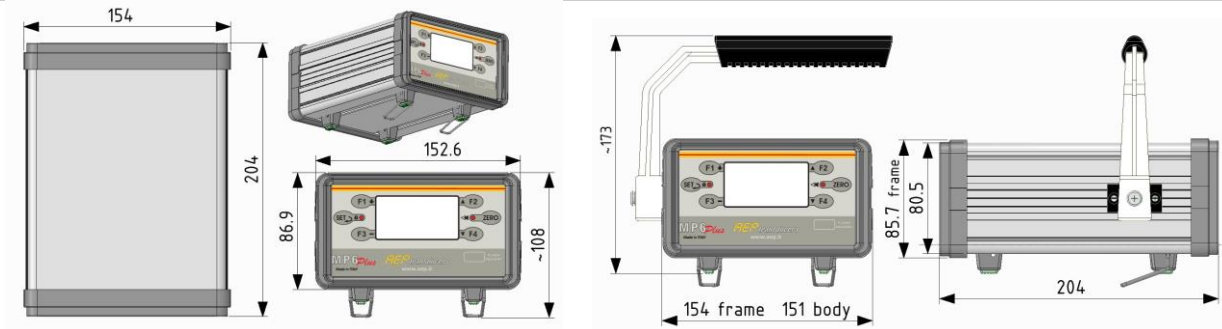

MOUNTING PANEL APPLICATION

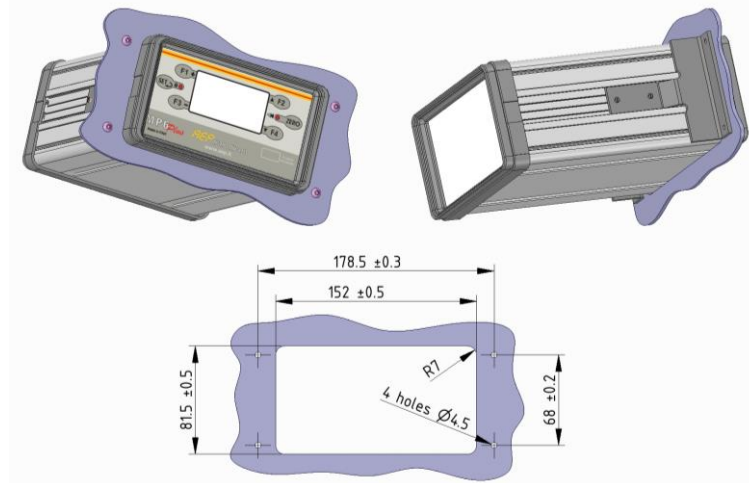

Note: For mounting panel requires 2 special brackets.

PURCHASE CODES

	Inputs	Power	Analog Output	Serial Output	Functions	Accessories	Digital Inputs
MP6P	X	XXX	XX	X	X	X	X
	2 2 inputs	230 230 Vac	A1 1 output	S RS232, RS458 Modbus, Printer	D Data logger Clock-Calendar	M Handle	N 4 Digital Inputs
	3 3 inputs	115 115Vac	A2 2 outputs	W Wireless Transmission	F Datalogger Clock-Calendar USB Flash Memory		
	4 4 inputs	24 24Vdc	A3 3 outputs				
			A4 4 outputs				

Example: **MP6P230** (MP6Plus power supply 230Vac base version)

Example: **MP6P224A2SM** (MP6Plus 2 channels- power supply 24Vdc + 2 Analog output + Serial output + handle)

Examples: **MP6P3115SF** (MP6Plus 3 channels power supply 115Vac + Serial output + USB Flash Memory)

ALWAYS SPECIFY in the purchase order how to configure the input channels:

Example: **CH1 = 4-20mA CH2 = 2mV/V CH3 = 10V CH4 = PT100**



41126 Cognento (MODENA) Italy Via Bottego 33/A Tel:+39-(0)59-346441 Fax:+39-(0)59-346437 E-mail: aep@aep.it

In order to improve the technical performance of the product, the company reserves the right to make changes without notice.