

MicroMate®

Serials General Vector Inverter

Power Range : 0.75kW-500kW



www.micromate.com.my



Official website

MicroMate Industries Sdn Bhd

Add : M4B/5, Jalan Pandan Indah 4/1A, Pandan Indah,
55100 Kuala Lumpur, Malaysia
Tel : +603-42978386
Fax : +603-42978382
Mobile : +6012-3566784
Email : sales@micromate.com.my
URL : www.micromate.com.my

General information

MicroMate Industries Sdn Bhd was established in 1999. With an impressive record of accomplishments, we have now gained a reputation as a renowned specialist in the field of power electronics. The features of our products are reliability, excellence and long service lifespan. We also customize our products to our clients' needs and specifications.

At **MicroMate Industries Sdn Bhd**, extensive design and development (D&D) is constantly performed to ensure that we are always at the forefront of innovative developments. We utilize efficient just-in-time (JIT) and just-in-case (JIC) inventory control systems for different categories of components, which enables us to source and stock them at low costs and thus allowing our clients to benefit from affordable prices.

The "think local, export global" strategy we employ gives us a competitive edge – our products are Malaysia based to keep costs low but still adhere to international standards. Thus, the stringent controls and testing we perform guarantee the reliability of our products.

At critical times, our products will serve as your trusted partner to ensure smooth operations of your business. From the stages of designing to the completion of products, we are ever eager to assist our valued clients in fulfilling specifications in order to achieve a mutual success.



Product introduction

G1 series general vector inverter is the first generation of general inverters which is developed by MicroMate Industries Sdn Bhd independently, covering the full power range of 0.75KW-500KW. The product is designed in conjunction with design concept of "high reliability, super performance, complete functions, easy to use, strong adaptability to the environment", combined with the application characteristics of domestic inverters and the technology advantages of the European and Japanese inverters.

Comprehensive protection function and the really independent air duct design give the product good reliability and safety.

Excellent EMC performance, rich and easy-to-use product functions, advanced control algorithms and strict crystal control make G1 series a general cost-effective inverter.



Product features

Various selection

Various assembly method

Central flange mounting assembly mode is available for 4.0kw inverter and above, which will meet all demand in different installation environment

G1 series all support bottom wall mounting assembly mode



Perfect I / O interface

- 7 group DI
- 1 group DO
- 2 group AI
- 2 group AO
- 2 group relay
- 2 group Power Supply

Support all kinds of function card, I/O card expand, which can meet various customization requirement



Superior performance

- Open loop vector control, large torque, 0.5HZ with 150% output

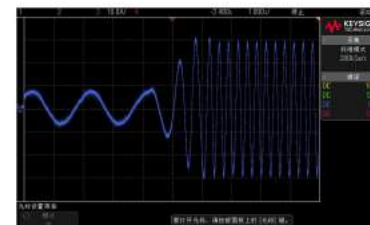

Quick-start Current wave form, 5.5kW asynchronous motor, 160% load

- Open loop vector control, quickly reaction of torque≤40ms



Sudden-load Current wave form, 5.5kW asynchronous motor, 0.5HZ, 60% load

- Perfect braking function, flux braking, stop DC braking, dynamic braking

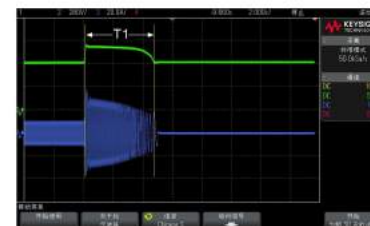

Flux braking effects



Flux braking uneffects

Overload ability

- G type : 150% - 60s 180% - 3s 200% - 0.5s
- P type : 120% - 60s 150% - 3s 180% - 0.5s

⚡ Reliable protection

■ Device selection Standard

Reliable device supplier
Reasonable device application



■ Temperature rise test standard

- Temperature rise test in single PCB during R&D process, make sure the thermal reliability .
- Temperature rise test in whole inverter with full load, to make sure thermal stress derating rule

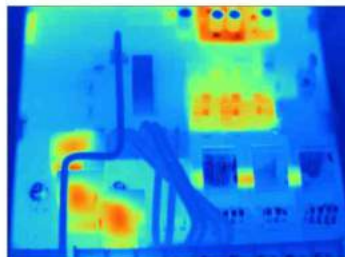

■ Three phase current detection

- Provide timely protection on output losing-phase or unbalance, to prevent motor from overheat damage
- Enhance the protection ability of motor for earth short circuit, ensure the safety of whole power system

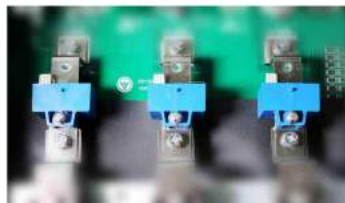

Environmental applicability and usability

■ Wide voltage range design

- Rated voltage : 4T 380 - 480 V
- Rated frequency : 50/60Hz
- Available voltage wave range : 320 - 528 V
- Degree of unbalancedness : < 3%
- Frequency range : 47 - 63Hz

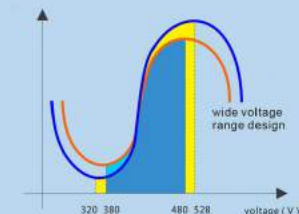

■ Independent air duct design

- Independent air duct design, really achieve isolation of top and bottom
- Provide independent sealing sleeve for capacitance assembly

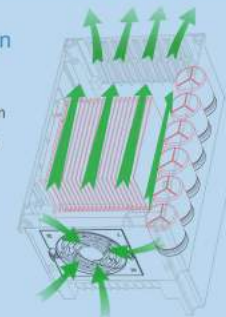

■ Dust mask

Provide dust mask to enhance protection ability of inverter



Easy fan maintainance

No need to open inverter, easy fan replacing and assembly, can be used in special environment which is hard to replace fan



Easy fan replacing method ▶

Compact structure design

- Smaller size, save the assembly room, convenient power distribution
- Save 20% for area size
- Save 30% for volume size



G1 series

Other brand

Intelligent terminal design

Avoid the connection mistake caused by sight fade zone during vertical installation

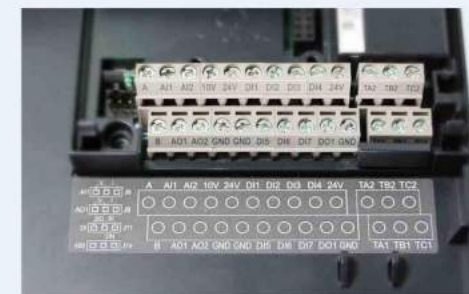

▲ Control circuit terminal



▼ Main circuit terminal



Two humanized fan replacing method

◀ Top replacing

Front replacing

Over 4.5kW



Industry applications

Machine tools, textile, packaging, chemical industry, transmission, fans and pumps, ceramic industry, woodworking machine



System wiring diagram

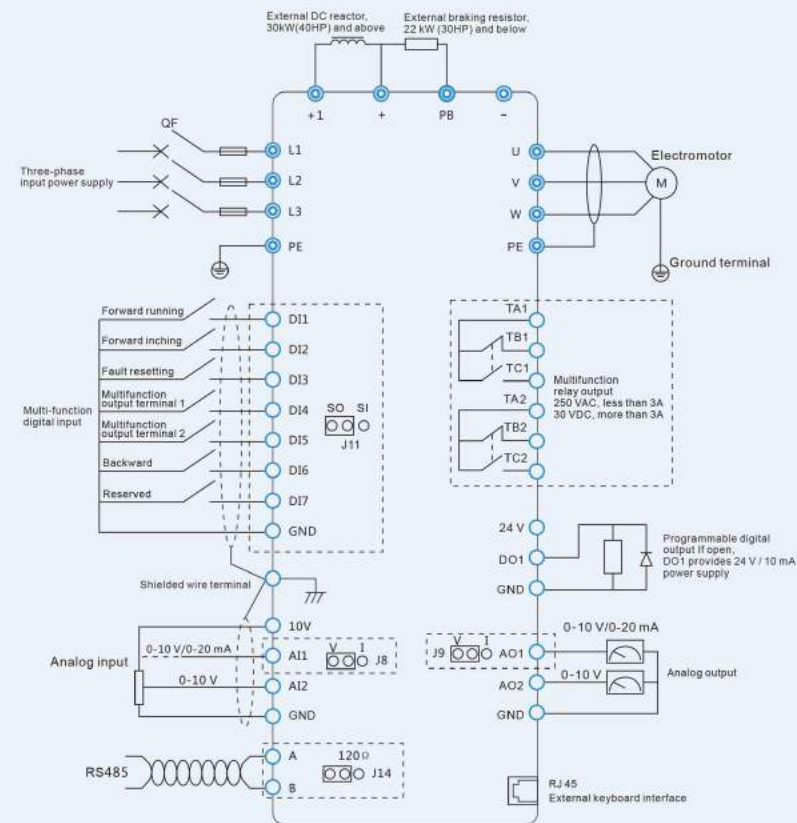

Note :
 Jumper J8: AI1 input 0 -10V, 0-20mA can be chosen
 Jumper J9: AO1 Output 0-10V, 0-20 mA can be chosen
 J11: DI input drain, source can be chosen
 Jumper J14:RS485 PC can be chosen

Technical specifications

Item		Specifications		
Input	Rated voltage, frequency	4T : 400 V, 50/60 Hz		
	Allowable voltage range	Range : 320-528V; degree of unbalance : <3%; frequency range : 47-63Hz		
output	Output voltage	0 - INPUT		
	Output frequency	0 - 1500 Hz		
	Overload capacity (180KW below)	G : 150% - 60s; 180% - 3s; 200% - 0.5s P : 120% - 60s; 150% - 3s; 180% - 0.5s		
Control features	Control mode	V/F control, open-loop vector control (SCV)		
	Starting torque	0.5 Hz 150% (SVC)		
	Range of speed regulation	1 : 200 (SVC)	1 : 100 (V/F)	
	Steady speed precision	±0.8% (SVC)		
	Speed fluctuation	±0.6% (SVC)		
	Torque response	≤40 ms (SVC)		
	Frequency precision	Low frequency mode		High frequency mode
		Digital setting : 0.01 Hz Analog setting : Max frequency <0.2%		Digital setting : 0.1 Hz Analog setting : Max frequency <0.2%
	Frequency resolution	0.01 Hz		0.1 Hz
	Modulation system	SVPWM		
	Carrier frequency	0.5- 16 KHz, based on model		
	Auto carrier adjustment	When the function is activated, the inverter can automatically adjust carrier frequency based on the temperature inside		
	Torque boost	In V/F control mode, the torque can increase by 0.1% -30% manually.		
	Torque curve	0: User customized V/F curve; 1: 2 power curve; 2: 1.7 power curve; 3: 1.2 power curve		
	Acceleration and deceleration time	0-6500.0 s, linear or sigmoid curve acceleration and deceleration mode, optional 4 groups of acceleration and deceleration time		
Basic functions	Inching function	Frequency range: 0.00-50.00 Hz		
		Acceleration and deceleration time: 0.1 – 60.0 s		
		Optional interval time: 0.0 – 100.0s		
	Simple PLC, multi speeds	Up to 16 speeds can be achieved through built-in PLC function and control terminal function		
	Internal PID	To achieve close-loop control		
	Wakeup	Process PID has sleep and wakeup function		
	Torque limit	The torque is limited during speed control to prevent frequent over-current alarm		
	DC brake	Starting frequency: 0.00 – max set frequency		
DC braking time: 0.01 – 30.00s (0.0: not activated) DC braking current: 0.0 – 100% rated current of the inverter				

Item		Specifications	
Basic functions	Auto voltage regulation (AVR)	When the input voltage deviates from the rated voltage, the function can be used to regulate the output voltage, so that AVR should be activated under normal circumstance, especially when the input voltage is higher than the rated voltage	
	Auto current limiting	When the input current reaches the auto current limiting, the function can adjust output frequency of inverter, so that the current will not be over the auto current limiting. This function will farthest avoid over current fault of inverter to keep the inverter uninterruptedly working.	
	Overvoltage stalling control	Used to control the voltage of DC bus during the running of the inverter to prevent overvoltage of DC bus	
Special functions	MODBUS communication	Standard MODBUS communication protocol for rapid communication with peripherals	
	Binding function	Operation command channel is bound with power input channel, without parameter setting	
	Input terminal drain/source section	Through jumper terminal, drain or source can be chosen for DI1- DI7 to meet the needs in different cases	
	Multi AI curve correction	Up to 4 points can be chosen to set AI curve for flexible and convenient curve correction	
	Double motor parameters	Two sets of parameters of asynchronous inverters are stored to achieve the switching function between two different motors	
Operation and running	Virtual I / O port	5 virtual DI/DO ports make complex logic control applications convenient	
	User customized parameter set	The customer can choose the required parameter set, sent to P14 as the custom parameter for daily view and modification	
	Command source channel	Three modes, keyboard setting, external terminal setting, communication setting, switchable	
	Frequency source channel	Digital setting, analog setting, pulse setting, multi-speed, communication setting etc. for selection	
	Input terminal	7 digital input terminals, DI1-DI7, drain and source input can be chosen DI7 can be used as a high speed pulse input, supporting 12 V and 24 V level, the maximum frequency of 50 KHz.	
		2 analog input terminals AI1:0 – 10V or 0-20 mA can be chosen; AI2: 0 – 10V can be chosen through parameter setting, 2 analog input terminals AI both can be used as digital input terminal DI	
	Output terminal	1 programmable switch output, the output level is 24 V when open	
2 programmable relay output, 250 VAC/3 A, 30VDC/ 3A			
		2 analog output terminals, AO1:0-10 V or 0-20 mA can be chosen ; AO2: 0-10V	

Nameplate and type designation

Nameplate introduction

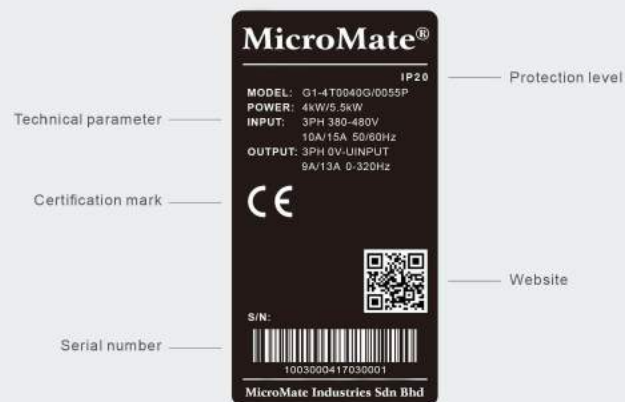

Type designation

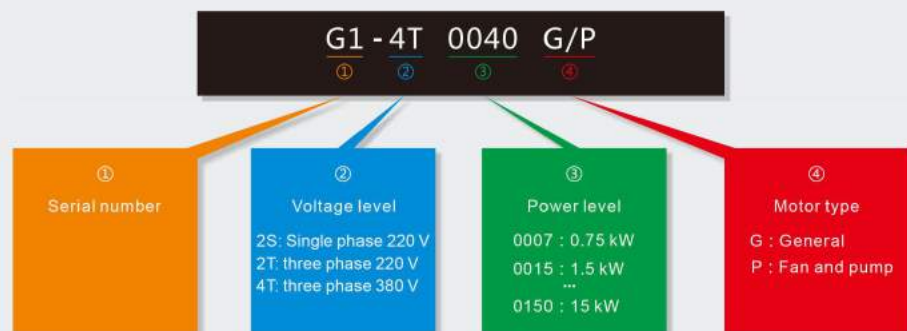

Technical parameters

Type	Fan and pump load (P-type)							
	Rated volume (kVA)	Rated output current (A)	Motor type		Rated volume (kVA)	Rated output (A)	Motor type	
			(kW)	(HP)			(kW)	(HP)
G1-4T0007G	1.7	2.5	0.75	1	—	—	—	—
G1-4T0015G	2.6	4	1.5	2	—	—	—	—
G1-4T0022G	3.4	5.2	2.2	3	—	—	—	—
G1-4T0040G/0055P	5.9	9	4	5	8.6	13	5.5	7.5
G1-4T0055G/0075P	8.6	13	5.5	7.5	11.2	17	7.5	10
G1-4T0075G/0110P	11.2	17	7.5	10	16.5	25	11	15
G1-4T0110G/0150P	16.5	25	11	15	21	32	15	20
G1-4T0150G/0185P	21	32	15	20	25	38	18.5	25
G1-4T0185G/0220P	25	38	18.5	25	30	45	22	30
G1-4T0220G/0300P	30	45	22	30	40	60	30	40
G1-4T0300G/0370P	40	60	30	40	50	75	37	50
G1-4T0370G/0450P	50	75	37	50	60	90	45	60
G1-4T0450G/0550P	60	90	45	60	75	110	55	75
G1-4T0550G/0750P	75	110	55	75	99	150	75	100
G1-4T0750G/0900P	99	150	75	100	116	176	90	120
G1-4T0900G/1100P	116	176	90	120	139	210	110	150
G1-4T1100G/1320P	139	210	110	150	164	250	132	175
G1-4T1320G/1600P	164	250	132	180	197	300	160	220
G1-4T1600G/1850P	197	300	160	220	224	340	185	250
G1-4T1850G/2000P	224	340	185	250	250	380	200	270
G1-4T2000G/2200P	250	380	200	270	273	415	220	295
G1-4T2200G/2500P	273	415	220	295	309	470	250	335
G1-4T2500G/2800P	309	470	250	335	342	520	280	375
G1-4T2800G/3150P	342	520	280	375	395	600	315	420
G1-4T3150G/3550P	395	600	315	420	421	650	335	480
G1-4T3550G/4000P	421	650	355	480	454	720	400	540
G1-4T4000G/4500P	454	720	400	540	530	810	450	600

Keyboard installation size

(Unit:mm)

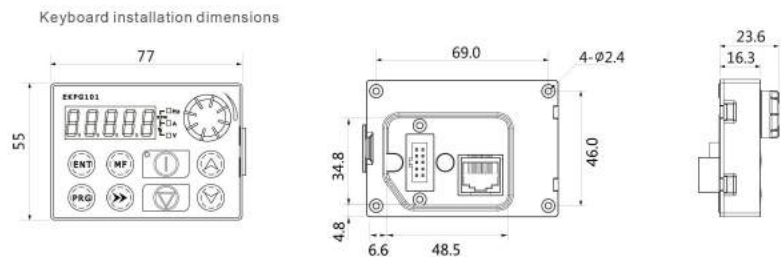

Foot mounting dimensions

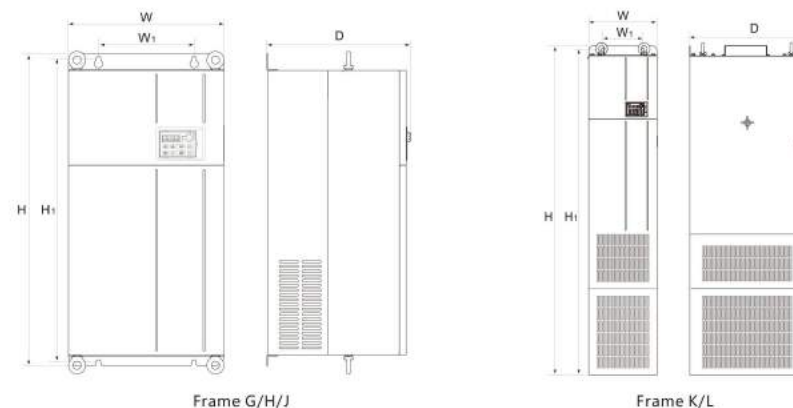
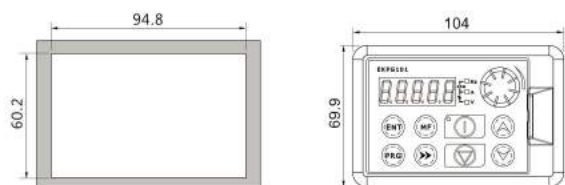

Installation dimensions

(Unit:mm)

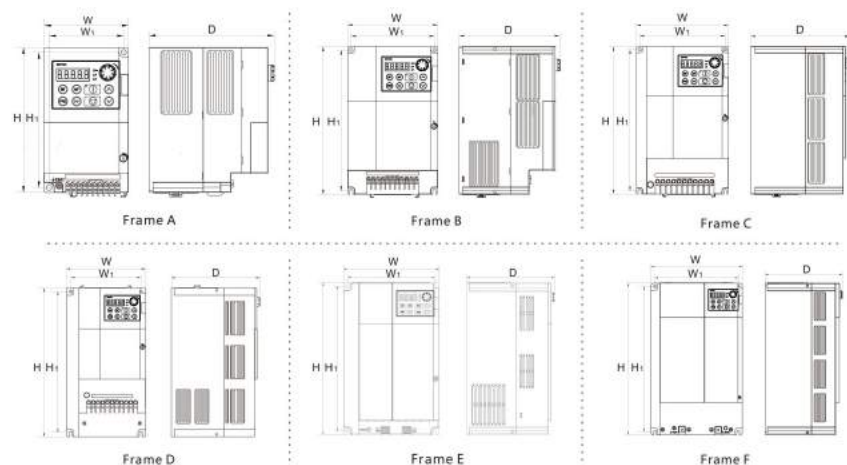

Frame	Inverter type	W1 (mm)	W (mm)	H1 (mm)	H (mm)	D (mm)	Screw size	Torsion	
								(kgf-cm)	(N-m)
A	G1-4T0007G G1-4T0015G G1-4T0022G	86	97	156	167	144	M5	30±10%	3±10%
B	G1-4T0040G/0055P G1-4T0055G/0075P	132	143	224	235	160.2	M5	30±10%	3±10%
C	G1-4T0075G/0110P	150.5	161.5	249	260	173.7	M5	30±10%	3±10%
D	G1-4T0110G/0150P G1-4T0150G/0185P	151	170	303.5	320	190.5	M5	30±10%	3±10%
E	G1-4T0185G/0220P G1-4T0220G/0300P	182	200	304.5	320	183.5	M5	30±10%	3±10%
F	G1-4T0300G/0370P G1-4T0370G/0450P	214	235	373	390	198.6	M6	45±10%	4.5±10%
G	G1-4T0450G/0550P G1-4T0550G/0750P	200	292	572	590	265	M8	110±10%	11±10%
H	G1-4T0750G/0900P G1-4T0900G/1100P G1-4T1100G/1320P	200	326	635	653	292	M8	110±10%	11±10%
J	G1-4T1320G/1600P G1-4T1600G/1850P	300	450	751	769	335	M8	110±10%	11±10%
K	G1-4T1850G/2000P G1-4T2000G/2200P G1-4T2200G/2500P G1-4T2500G/2800P	180	307	1469	1490	542	M12	390±10%	39±10%
L	G1-4T2800G/3150P G1-4T3150G/3500P G1-4T3500G/4000P G1-4T4000G/4500P	250	345.5	1740	1765	541	M16	980±10%	98±10%

Optional device

Dust mask

- For preventing pollution from going into inverter, dust mask should be chosen when inverter work environment is bad
- Inverter has to be derated when using dust mask
- Plastic case inverter(0.75kw-37kw) can support dust mask



Keyboard base

- Keyboard base is optional device for 0.75kw-37kw
- Keyboard base is standard device for 45kw and above



Flange mounting frame

- Flange mounting frame should be chosen when inverter is using flange mounting assembly method
- Only 4kw-37kw can support flange mounting frame



Project References

 <p>DBKL Project 12 photos</p>	<p>Government Linked Corporations</p> <ul style="list-style-type: none"> ▶ Telekom Malaysia Bhd ▶ Tenaga Nasional Bhd ▶ Malaysia Airlines System Bhd ▶ Petronas ▶ Sime Darby Bhd ▶ Permodalan Nasional Berhad (PNB) 	<p>Government Agencies</p> <ul style="list-style-type: none"> ▶ Jabatan Kerja Raya ▶ Majlis Perbandaran Kuala Lumpur ▶ Dewan Bandaraya Kuala Lumpur ▶ Jabatan Perdana Menteri ▶ Jabatan Ukur & Pemetaan ▶ Jabatan Kimia Malaysia ▶ Jabatan Kementerian Kesihatan ▶ Jabatan Bomba ▶ Kementerian Pertahanan 
<p>Universities</p> <ul style="list-style-type: none"> ▶ Universiti Malaya ▶ Universiti Antarabangsa Islam ▶ UTeM ▶ Universiti Sains Malaysia ▶ Universiti Putra Malaysia ▶ Universiti Tenaga Nasional Bhd ▶ Universiti Malaysia Perlis ▶ Universiti Malaysia Sabah 	<p>Hospitals</p> <ul style="list-style-type: none"> ▶ Hospital Besar KL ▶ Hospital UKM ▶ Hospital Seremban ▶ Hospital Sultanah Aminah, JB ▶ Hospital Sri Manjung, Perak ▶ Hospital Ampang ▶ Hospital Langkawi ▶ Hospital Banting ▶ Hospital Batu Pahat ▶ Hospital Shah Alam ▶ Hospital Bukit Mertajam ▶ Hospital Cameron Highland ▶ Hospital Melaka 	<p>Expressways Operators</p> <ul style="list-style-type: none"> ▶ PLUS ▶ ELITE  <p>A member of UEM</p>
<p>Banks</p> <ul style="list-style-type: none"> ▶ Hong Leong Bank Bhd ▶ CIMB Bank Berhad ▶ Bank of India ▶ Bank of Tokyo 	<p>Hotels</p> <ul style="list-style-type: none"> ▶ Hyatt Hotel Johor ▶ Grand Hyatt Hotel ▶ Hotel Mutiara, JB ▶ Q Hotel Kuala Lumpur ▶ D'Malaqa Hotel (Melaka) 	<p>Airports</p> <ul style="list-style-type: none"> ▶ Kuala Lumpur International Airport (KLIA) ▶ Penang Airport ▶ Senai Airport 
<p>Corporate Sectors</p> <ul style="list-style-type: none"> ▶ CELCOM ▶ DIGI ▶ REDTONE Telecommunications S/B ▶ Mecomb Malaysia S/B ▶ Shell Malaysia Bhd ▶ IOI Lipid Enzymtec S/B ▶ Fujifilm S/B 	<p>Franchise F&B outlets</p> <ul style="list-style-type: none"> ▶ The Coffee Bean & Tea Leaf 	<p>Overseas</p> <ul style="list-style-type: none"> ▶ Singapore Genting ▶ Australia ▶ Vietnam ▶ Cambodia 