

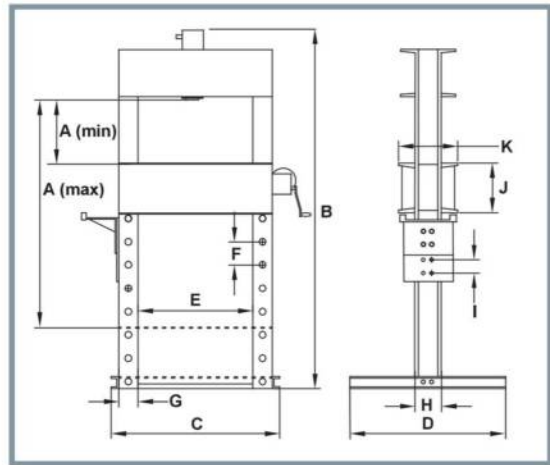

**WILLIAMS**

## 55/100 TON SHOP PRESS

- Heavy steel welded construction
- Multi-position bed for work height adjustment
- Ideal for the removal or installation of gears, universal joints, pulleys, wrist pins, and other press jobs
- Excellent for bending, bonding or straightening applications



### 55/100 TON SHOP PRESS SPECIFICATIONS

Product Code	Capacity (Tons)	Pump Model	Pump Type	Stroke Length	Bed Position	Product Size (H X L X W)	Working Space (A Min. / A Max.) (in)	Weight (lbs)
9A55T06	55	5AS150	AIR	6	9	79" X 56" X 30"	14" ~ 55-1/2"	760
9E55T06		5E05H1GR	ELECTRIC	6				
9H55T06		5HS25200	MANUAL	6				
9A55T13		5AS380	AIR	13				
9E55T13		5E05H1GR	ELECTRIC	13				
9E100T10	100	5E10H2GR	ELECTRIC	10	8	89" X 63" X 30"	11-1/4" ~ 51"	1550

### 55/100 TON SHOP PRESS DIMENSIONS

Product Code	Dimensions (in)											
	A (Min.)	A (Max.)	B	C	D	E	F	G	H	I	J	K
9A55T06	14	55.5	79	56	30	35.4	6	4	9	3	10	14.8
9E55T06												
9H55T06												
9A55T13												
9E55T13												
9E100T10	11.3	51	89	63	30	35.5	8	N/A	10	N/A	12	16