

ELECTROMAGNETIC DOOR HOLDERS



DESCRIPTION

DEMCO Electromagnetic Door Holders are attractively designed and ruggedly constructed for easy and versatile installation. The contact plate can be adjusted to suit any door angle. These door holders come with a typical holding force of approximately 12–100kg and can hold most type of doors. Ideal for use with self-closing fire and smoke barrier doors.

In application, the device releases the door when signaled by the fire alarm system, which then allows the door closing mechanism to close the door. DEMCO Electromagnetic Door Holders also have a Manual Release Switch to release the door manually or to test the operation of the unit. Each unit is housed in high grade ABS Polycarbonate casing and has a built-in Brass Pin Instant Release that is designed for better reliability and performance.

DEMCO ADVANTAGES

- Incorporation of Manual Release Switch.
- Residual Magnetism Release Brass Pin – for instant release.
- Customized holding force available upon request.
- Wide angle rotatable Contact Plate.
- High holding force.
- Easy visible access from side and rear.
- 220/240VAC version is fitted with power fuse.

SPECIFICATIONS

D-111 AC



D-111

	D-111	D-111 AC
Size (H x W x D)	100 X 100 X 50mm	
Operating Voltage	15-29V DC	220-240VAC
Operating Current	60 mA	8mA@230VAC
Input Power	1.5 W	2 W
Holding Force	588N/60kg/132lbs 343N/35kg/77lbs 201N/20.5kg/45lbs	588N/60kg/132lbs
Net/Gross Weight	680/730g	690/740g

* Please specify holding force when ordering

Wiring for MDH in parallel

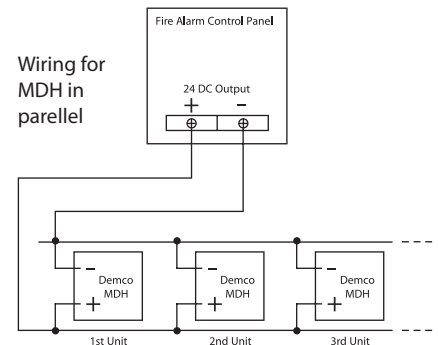

D-131



Size (H x W x D)	93 X 93 X 43mm
Operating Voltage	15-29V DC
Operating Current	40 mA
Input Power	1 W
Holding Force	294N/30kg/66lbs
Net/Gross Weight	400/450g

D-141



Size (H x W x D)	100 X 90 X 55mm
Operating Voltage	15-29V DC
Operating Current	180 mA
Input Power	4.5 W
Holding Force	980N/100kg/220lbs
Net/Gross Weight	1260/1320g

D-151



Size (H x W x D)	80 X 72 X 53mm
Operating Voltage	15-29V DC
Operating Current	60 mA
Input Power	1.5 W
Holding Force	588N/60kg/132lbs
Net Gross Weight	600/674g

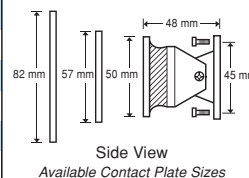

CATCH PLATE EXTENSION ROD

D-121/6

Length: 155mm

D-121/8

Length: 203mm

D-121/12

Length: 305mm



Standard catch plate included.

 **DEMCO**
INDUSTRIES SDN BHD
www.demcoalarm.com

Lot 3928, Jalan Keretapi Lama
Off Jalan Kapar 5 1/2 Miles
42100 Klang
Selangor Darul Ehsan
West Malaysia
Tel: +603-3290 3333
Fax: +603-3290 2288
E-mail: sales@demcoalarm.com



Specifications are subject to change without prior notice.

Quality without Compromise