



MODELS | SJIII 6826 SJIII 6832



## CONVENTIONAL SERIES DC Electric SCISSOR LIFTS

The Wide Conventional Series DC Electric Scissor Lifts offer high capacity, while boasting the largest platforms in their class. Featuring variable speed rear wheel hydraulic drive, the SJIII 6826 and SJIII 6832 offer working heights up to 38', capacities up to 1200 lbs, and 25% gradeability.

A standard 3' roll out extension deck can be secured in multiple positions, and both models can be driven at full height. Consistent with Skyjack's robust and reliable design features, the Wide Conventional Series DC Electric Scissor Lifts are built using Skyjack's

standard color coded and numbered wiring system. Analog based controls with a relay based electrical system ensures these units will maintain their industry leading life cycle value.

# CONVENTIONAL SERIES DC Electric Scissor Lifts

Specifications	SJIII 6826	SJIII 6832
A Work Height	32' (9.8 m)	38' (11.6 m)
B Raised Platform Height	26' (7.9 m)	32' (9.8 m)
C Lowered Platform Height	50" (1.3 m)	55.5" (1.4 m)
D Overall Width	68" (1.7 m)	68" (1.7 m)
E Overall Length	99.5" (2.5 m)	99.5" (2.5 m)
F Stowed Height (Rails Up)	93.5" (2.4 m)	99" (2.5 m)
G Stowed Height (Rails Down)	78.5" (2.0 m)	84" (2.1 m)
H Platform Width (Inside Dimension)	57" (1.4 m)	57" (1.4 m)
I Platform Length (Inside Dimension)	84" (2.1 m)	84" (2.1 m)
Deck Extension	3' (0.9 m)	3' (0.9 m)
Ground Clearance	7.5" (0.2 m)	7.5" (0.2 m)
Wheelbase	76" (19.0 cm)	76" (19.0 cm)
Weight	5,380 lbs (2,440 kg)	5,680 lbs (2,576 kg)
Gradeability	25%	25%
Turning Radius (Inside)	76" (1.9 m)	76" (1.9 m)
Turning Radius (Outside)	164" (4.2 m)	164" (4.2 m)
Lift Time (With Rated Load)	65 sec	60 sec
Drive Speed (Stowed)	2 mph (3.2 km/h)	2 mph (3.2 km/h)
Drive Speed (Raised)	0.7 mph (1.1 km/h)	0.7 mph (1.1 km/h)
Maximum Drive Height	Full Height	Full Height
Capacity (Overall)	1,200 lbs (544 kg)	850 lbs (386 kg)
Maximum # of Persons	3	3

## STANDARD FEATURES

- Drivable at full height
- Variable speed, rear two wheel hydraulic drive
- Dual holding brakes
- Proportional controls for drive & lift functions
- 3' (0.9 m) roll out extension deck
- 24V DC power source
- Low voltage battery protection
- Analog control system
- Color coded and numbered wiring system
- 25% gradeability
- Black foam-filled tires
- 110V AC outlet on platform with GFI
- Tilt alarm with drive & lift cut-out
- All motion audible alarm
- Operator horn
- Hinged railing system
- Lanyard attachment points
- Forklift pockets and tie down/lift lugs

## OPTIONS†

- Flashing light
- 5' powered extension deck\*  
\*adds 250 lbs to unit weight, 6826 capacity is reduced to 1,000 lbs, 6832 capacity remains the same
- Shop airline to platform
- 800 watt AC inverter
- Half height spring hinged gate
- Full height spring hinged gate
- Non-marking, foam-filled tires
- EE rating package
- Air operation package

† Capacities, and machine weights may differ when options are added

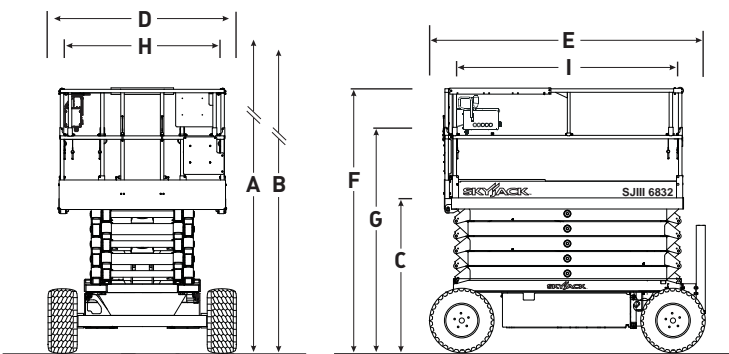

## Skyjack Head Office

55 Campbell Rd. Guelph, ON Canada N1H 1B9  
 Sales Inquiries: 1-877-755-4387 (1-877-SJLIFTS)  
 Main Switchboard: 1-800-265-2738  
 Phone: 519-837-0888  
 Fax: 519-837-8104  
 Email: skyjack@skyjack.com

[www.skyjack.com](http://www.skyjack.com)

This brochure is for illustrative purpose only and based on the latest information at the time of printing. Skyjack Inc. reserves the right to make changes at any time, without notice, to specifications, standard and optional equipment. Consult the Operating Maintenance and Parts Manuals for proper procedures. Work platforms have been tested to comply with ANSI and CSA standards as interpreted by Skyjack, Inc.

