

# Continuous Monorail Rotary Blasting Machine

## Model CMR6D9H

Continuous Shot Blasting Machine  
Design, Fabrication, Installation  
Training & Technical Documentations  
For Rail Coaches Wheel Bogie Parts

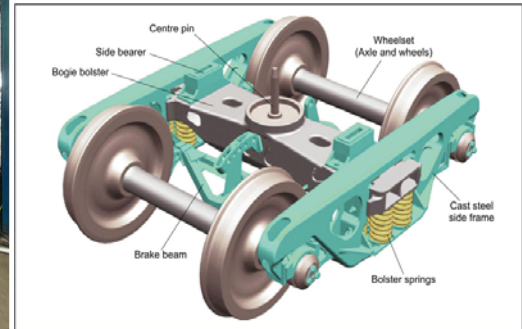

Site Commissioning - Works Pieces are Bogie Bolster and Cast Steel Side Frames at 3 min/pc Through-Put



Pics Bogie Bolster - Loading Side Frame - Control Station - Trolley Conveyor & Drives - Completed Finishes

## CONTRACT MAIN SPECIFICATIONS

- Steel castings or fabricated steel works that can fit into an envelope size of 1.85m diameter x 2.65m high x 2 tons load per hanger with 6 hangers on full loading.
- Overhead chain conveyor moves in indexing forward & stop for rotary blasting repeatedly.
- Work piece can be hung and rotated for blasting & rotation is capable of CW & CCW direction in PLC programmed manner.
- Works loading & unloading platforms are installed for ease of access in auto-swing manner for ease both loading & unloading.

## TECHNICAL DATA of Winning Design & Tender

- \* Double chambers blasting station design
- \* Hanger rotating speed @ 3 rpm
- \* Blast wheel motor @ 15kw x 10 sets installed + 2 units spare
- \* Elevator gear motor \* 4kw x 2 sets
- \* Lower long screw gear motor @ 1.5kw x 2 sets
- \* Lower cross screw gear motor @ 2.2kw x 2 sets
- \* Dust collector fan motor @ 18.75kw 17,900 CMH 9" w.g.
- \* Hanger rotator gear dirve @ 0.75kw x 2 sets
- \* Caterpillar chain drive @ 4kw of type X678 chain series



Filter Bag Type Dust Collector