

### Weights

Operating weight with ROPS cab , tires, standard bucket (SAE J732)	5550 kg
Additional weight for long dipperstick	20 kg

### Engine

Make / model	Yanmar / 4TNV98-EPDBW
Fuel	Diesel
Number of cylinders	4
Displacement	3300 cm <sup>3</sup>
Maximum NET power (ISO 9249)	40.8 kW
Maximum NET torque (ISO 9249)	206.0 Nm

### Performance

Digging force, standard dipperstick (ISO 6015)	27000 N
Digging force, long dipperstick (ISO 6015)	24000 N
Digging force, bucket (ISO 6015)	41000 N
Drawbar pull	31000 N
Travel speed, low range	10.0 km/h
Travel speed, high range	30.0 km/h

### Hydraulic System

Pump type	Two engine-driven piston pumps and two engine-driven gear pumps
Total pump capacity	180.30 L/min
Auxiliary flow	52.50 L/min
System relief pressure for auxiliary circuit 3	230.00 bar
System relief pressure for auxiliary circuit 2	210.00 bar

### Slew System

Boom swing, left	80°
Boom swing, right	50°
Slew rate	8.7 RPM

### Fluid Capacities

Cooling system	10.00 L
Engine lubrication plus oil filter	11.60 L
Fuel reservoir	120.00 L
Hydraulic system	147.80 L

### Environmental

Noise level LpA(EU Directive 2006/42/EC)	76 dB(A)
Noise level LWA(EU Directive 2000/14/EC)	97 dB(A)
Whole body vibration (ISO 2631-1)	0.26 ms <sup>-2</sup>
Hand/arm vibration (ISO 5349-1)	0.81 ms <sup>-2</sup>

### Standard Features

1920 mm dozer blade	Lockable storage compartment
1600 mm dipperstick	Horn
Boom load holding valve	Work lights
Dozer blade safety valve	Retractable seat belt
Fully adjustable air conditioning	TOPS/ROPS cab <sup>1</sup>
Suspension seat with high back	Harness for rotating beacon
Consoles with forwards/backwards adjustable displacement	Overload warning device
Steering column with adjustable angle	Sun visor
Second auxiliary hydraulic line (Rotation piping)	Two left and one right rear view mirrors
Fingertip auxiliary hydraulic control	Electric refueling pump
Control console locks	Auto idle
Hydraulic joystick controls	Warranty: 12 months, 2000 hours (whichever occurs first)
Two-speed travel	

1. Tip Over Protective Structure (TOPS) – Meets requirements of ISO 12117

### Working Range

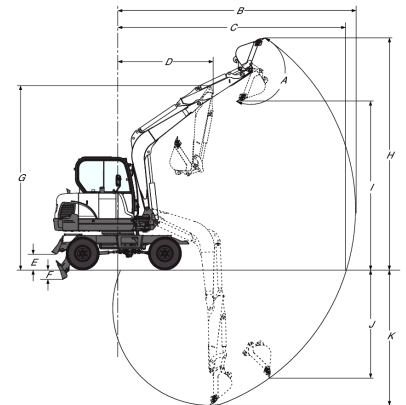

(A)	180°	(F)	205.0 mm
(B)	6110.0 mm	(G)	4665.0 mm
(B)	6400.0 mm	(H)	5980.0 mm
(C)	5980.0 mm	(H)	6170.0 mm
(C)	6190.0 mm	(I)	4265.0 mm
(D)	1980.0 mm	(I)	4455.0 mm
(D)	1990.0 mm	(K)	3495.0 mm
(E)	420.0 mm	(K)	3795.0 mm

### Dimensions

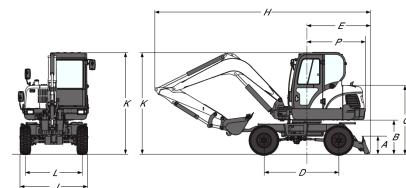

(A)	500.0 mm	(H)	6120.0 mm
(B)	980.0 mm	(J)	1920.0 mm
(C)	1935.0 mm	(K)	2855.0 mm
(D)	2100.0 mm	(O)	1980.0 mm
(E)	1842.0 mm	(P)	1650.0 mm
(F)	4260.0 mm		

### Options

Long dipperstick	Third auxiliary hydraulic line (Clamshell Piping)
Twin tyres with 2290 mm dozer blade	