

BENINCA[®]
TECHNOLOGY TO OPEN



YAK20 OM

230 V AC single-phase gear motor with integrated control panel



YAK20 OM

BENINCA[®]
TECHNOLOGY TO OPEN

The new motor **230 Vac** single-phase, evolution of the BULL20M model, for the automation of sliding gates of **up to 2000 kg**, is here.

Equipped with an integrated control panel with electronic safety wiring, the **YAK20 OM** is lubricated with a particular type of oil to guarantee excellent performance also at low temperatures.

The location of the control panel, at the top of the motor, facilitates wiring operations and relevant programming.



Like the BULL range, the **YAK20 OM** comes with a spring stop and also allows for the installation of photocells (PUPILLA). It also boasts a rapid and intuitive release system with customised key.



Raised foundation plate included.

The intensity with which it can be used is guaranteed by a number of design details regarding the self-cooling system and the finned motor.

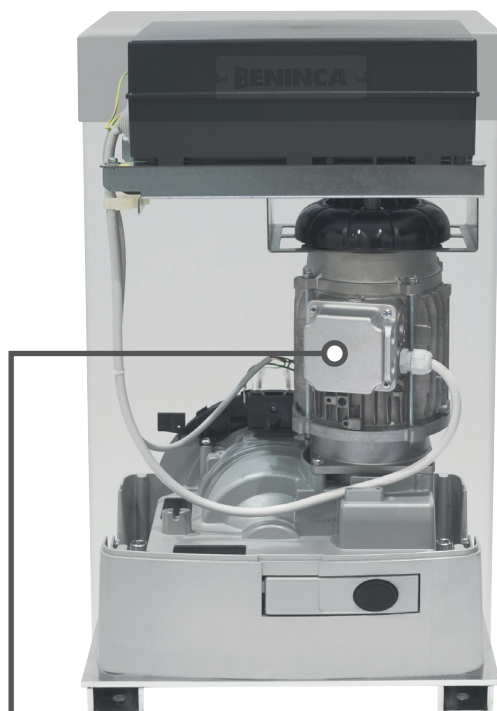
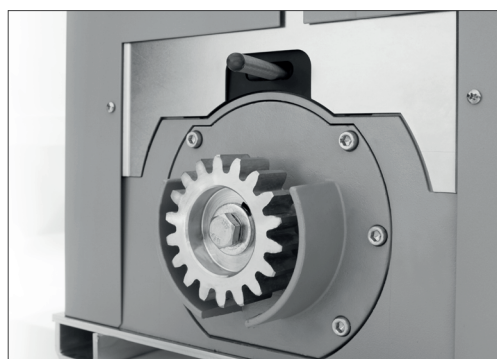
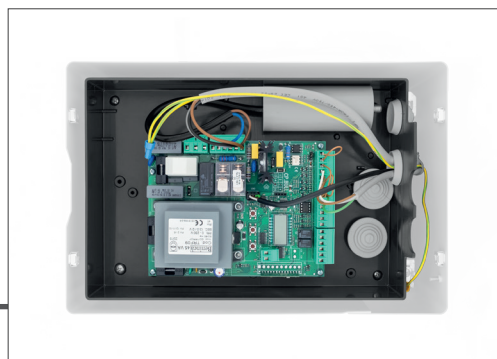

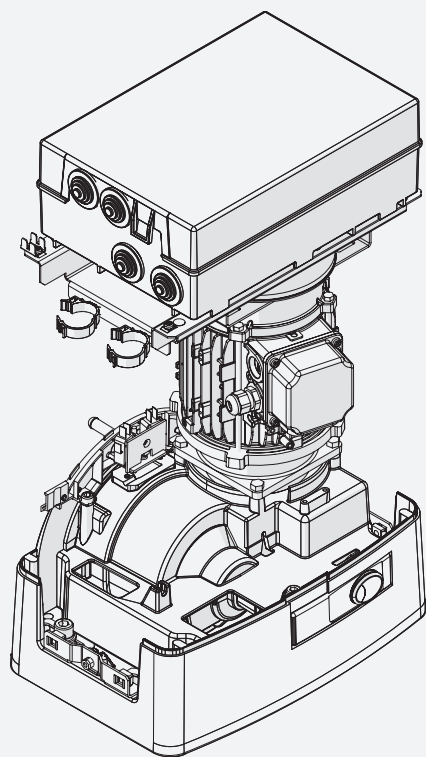

The new series of BENINCA motors for industrial gates further expands what is already a very wide range of solutions, meeting all of the market's requirements with its various specific models.

Technical data

Power supply	230Vac 50/60Hz
Max absorbed current	2,5 A
Max Thrust	1250 N - 45 Nm
Operating jogging	Heavy duty
Protection level	IP44
Operating temperature	-20°C / +50°C
Condenser	25 µF
Max gate weight	2000 kg
Rack module	M4 Z 18
Opening speed	10,5 m/min
Noise level	<70 dB
Lubrication	OIL
Weight	31,2 kg



www.beninca.com

BENINCA[®]
TECHNOLOGY TO OPEN

AUTOMATISMI BENINCÀ SpA

via del Capitello, 45

36066 Sandrigo (VI) ITALY

T +39 0444 751030

F +39 0444 759728

sales@beninca.it

