

HELI

• EFFICIENT • QUALITY • TRUSTWORTHY

10.0t

8.0t



h2000
SERIES

ENGINE POWERED 8.0 & 10.0 t
CPCD80 / 100

Import & distribute by:
UNITRACK HELI SDN. BHD. (593857-P)



ISO9001
ISO 9001 CERTIFICATION

CE
CE CERTIFICATION

PERFORMANCE

Model		CPCD 80	CPCD 100
Load Capacity	kg	8000	10000
Load Center	mm	600	800
Standard Tire		6pcs	6pcs
Tire (Front)	four	9.00-20-14PR	9.00-20-14PR
Tire (Back)	two	9.00-20-14PR	9.00-20-14PR
Lifting Speeds (Unloaded / Loaded)	mm/s	440/400	370/330
Max Towing (Unloaded / Loaded)	kN	27/60	31/58
Gradeability (Loaded)	%	25	21
Max Travelling Speed (Loaded / Unloaded)	Km/h	26/30	26/30

DIMENSIONS

Standard Maximum Fork Height	H3	mm	3000	3000
Free Lift	H2	mm	200	210
Fork Size (L x W x T)	L3/W/T	mm	1220 x 170 x 70	1220 x 175 x 80
Tilt Angle (F/B)	f/o	Deg	6/12	6/12
Overall Length (With Fork)	L1	mm	5160	5480
Overall Length (Without Fork)	L2	mm	3940	4280
Overall Width	B	mm	2165	2165
Overhead Guard Height	H6	mm	2560	2560
Overall Height of Mast	H1	mm	2700	2850
Max height for Raised (With Load Bracket)	H4	mm	4420	4330
Min Turning Radius	Wa	mm	3700	3900
Max Intersecting Aisle	RASA	mm	3310	3540
Service Weight		kg	10980	12510
Minimum Underclearance (Bottom of the Mast)	Z	mm	250	245
Front Overhang	X	mm	700	718
Rear Overhang	L4	mm	740	740

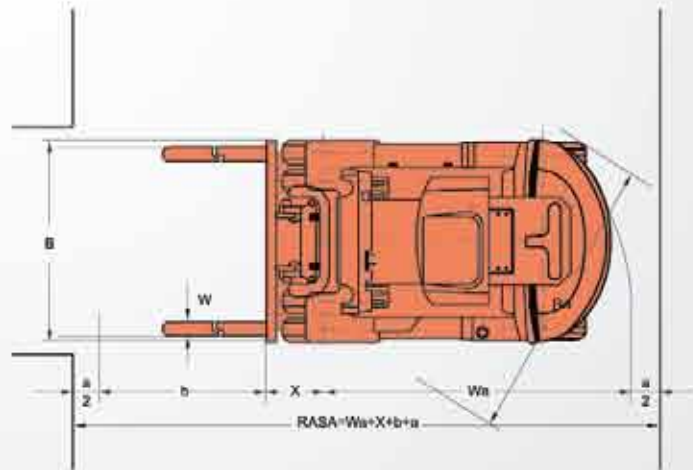
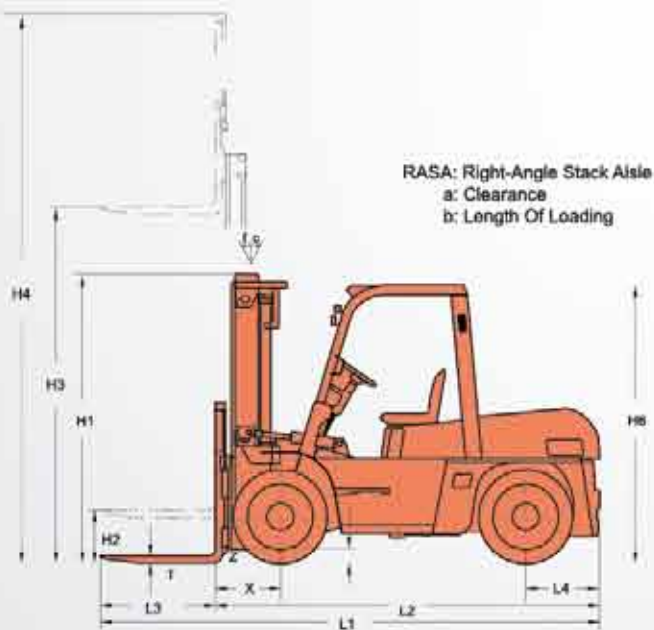

ENGINE OPTION

Engine Model	ISUZU
Fuel Type	Diesel

ENGINE PERFORMANCE

Rate Output / Speed	kw(hp) / rpm	82.3 (110) / 2000
Rate Torque / Speed	N.m (kg.m) / rpm	415 / 1400 - 1600
Cylinder Number	Quantity	6
Total Displacement	ml	6494