

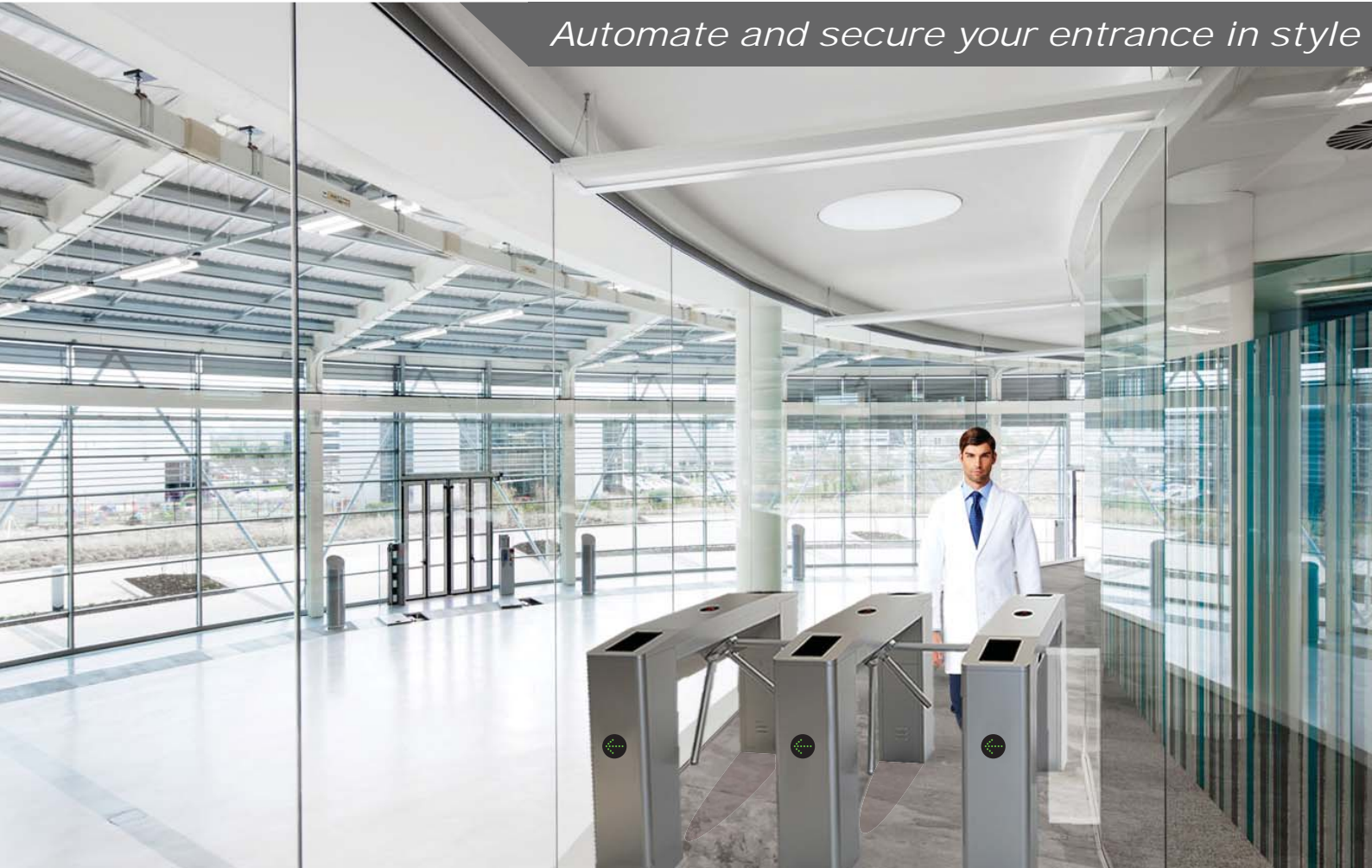

IS YOUR FIRST STEP  
IN SECURITY

*Automate and secure your entrance in style*



## Semi Automatic Tripod Turnstile

Model : TTS351L series

TTS351L is an electro mechanical waist height tripod turnstile. It's unique mechanical drive design allow the arm to be pushed effortlessly and auto-rotate back without any expensive electric motor.

TTS351L series can effectively control high volume human traffic ( up to 25 person per minutes ) while still maintaining a welcoming atmosphere. They can easily be integrated with any electronic system for ticketing, access control or time attendance. TTS351L series is suitable for indoor ONLY. It is NOT suitable to be installed outdoor or near sea side. They are optimized economical solution for railway, bus station, factory, colleges, commercial building, library, stadium, game park, bank and etc.



Premium  
automation



## TECHNICAL SPECIFICATION:

Description	Parameters
Pass speed	25 person per min
Response time	0.3 sec
Power supply input	AC230V ± 10V
power consumption	Idle 16W Operating 38W

## DIMENSION:

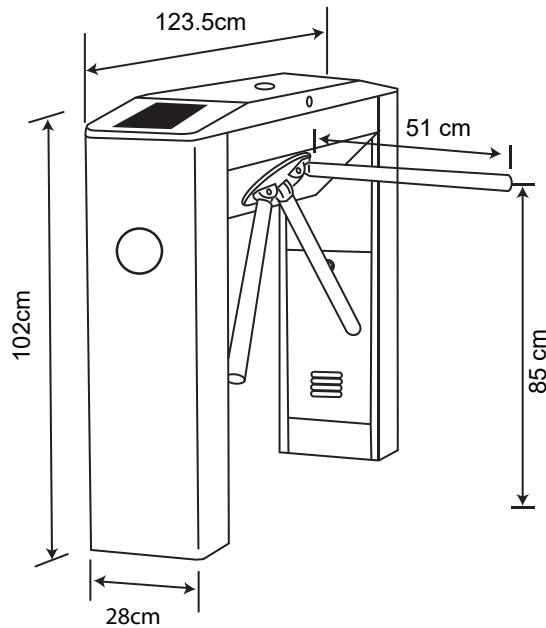

## ORDERING INFO:

Model No	Description
TTS351L	Standard tripod turnstile with additional LED light

## ACCESSORIES:



Safety beam



Push Button

Authorized dealer

## Feature

### 1 EASY MAINTENANCE

Common parts are modular and can be easily changed by simply removing screws. Top cover can be opened for full access into internal mechanism during servicing. Regular wear and tear parts can be purchased to keep stock for faster replacement.

### 2 SEMI AUTO ROTATION

Its unique mechanical drive design allow the arm to be pushed effortlessly and auto-rotate back without any expensive electric motor. If arm rotated more than half, it will auto-rotate to the next idle position. If arm rotated less than half, it will auto-rotate back to the current idle position. Adjustable absorber controls rotation force to minimize loud sound and avoid over rotation.

### 3 ANTI TAIL-GATING

Smart lock mechanism effectively allow only one person to pass through at a time. Arm will automatically relock back if nobody pass through after a preset delay time.

### 4 USER FRIENDLY

LED at top cover indicates approved entry direction after flash card. LED at each leg indicate if the lane is available or closed down for servicing. During power failure, arm will drop automatically allowing free pass through. Arm is manually lifted up back to position after power resumed.

### 5 EASY INTEGRATION

Turnstile is triggered to open via dry contact relay output for bi-directional or uni-directional entry. RFID reader can be easily installed underneath side black arylc. Top cover and and side leg can be opened to install external devices.

“ Entrance is the first level of protection in building security. MAG offer complete gate automation system to secure your entrance.... ”

