

General Description

AST BR600T series modern gray concept effectively increase premium prestigious impression of guard house entrance at any high end lifestyle residential, premium commercial building or boutique factory.

AST BR600T design is well balanced between performance, stability and affordability. It is not the best barrier gate in the world that is too high cost to buy. It is not the super low cost barrier gate using cheap component that always break down. AST BR600T design philosophy is to be "good enough" and affordable for target application.

AST BR600T is backed up with comprehensive local spare parts. Fast spare parts availability is important to ensure your barrier resume operation in shortest time possible in the event of break down.

Application

Suitable for indoor as well as outdoor parking area at airport, shopping mall, warehouse, hotel, factories, condominium, car rental companies, etc. It can also be customized to be used together with any auto-pay ticketing parking or access control system.

Features

Intelligent. Advanced smart motor control system is combined with unique lever design to achieve swift arm movement that reduces bouncing at end position.

DSP Dual Spring mechanism to achieve two times smoother arm motion. Combination of different tension force reduced vibration as the arm stop. Well balanced arm weight reduces the possibility of broken spring thus reducing down time.

DSD Dual Sensor Detection to achieve double safety. Innovative design monitors current spike and motor rotation simultaneously to auto-reverse arm if blocked by obstacle. This is an important safety feature to prevent further damage in the event when arm hit car or pedestrian.

BlueSpeed motor uses lowest possible rotation speed (RPM) with our force rotation ratio technology to achieve high speed opening. This reduces mechanical wear and effectively eliminates any maintenance servicing on the motor.

Improved air ventilation. New fan design located at top instead of sideways. This allowed cool air enter from bottom and exit from top to achieve more efficient cooling this enabling AST BR600T series to support higher flow of traffic.

Improved NLSV2 design. NLS V2 is using magnet sensor instead of optical sensor. Optical sensor is subjected to interference from ambient light level. New NLS design removed all blind spot area to achieve perfect opening and closing consistently.

Safe. Arm will auto-reverse when hitting an obstacle during closing. Photo beam can be added to auto-reverse the arm ahead of time before hitting approaching vehicle or human. Arm will swing out during direct collision from front avoid arm frequently broken (only available in BR618T and BR630T).

Traffic light (red & green can be added to indicate permission to pass through and further enhance safety usage. Built-in MCB to protect against any electric hazard.

Heavy Duty. Enhanced NLS design eliminates the use of mechanical limit switch thus reducing mechanical wear and tear. Innovative counter weight spring design avoids possibility of motor over-stressed and break due to high volume continuous open/close cycle. All these allow BR600 to work harder and work longer for you.

Fast speed. BR618T's 1.8 sec fast opening / closing speed allow more car to pass through faster thus effectively reducing congestion during peak hours.

User Friendly. In the event of power failure, arm can be easily lifted up by insert a key from outside to unlock the clutch. There is no need to open up entire casing to avoid any vandalism attempt of internal parts.

Easy maintenance. Epoxy powder paint will keep the unit looking clean and new for years. Damaged barrier arm can be replaced easily. AC based motor is stronger and maintenance free (no need to change carbon).

Technical specification

Mechanical unit

Consist of the drive motor, speed reduction gear box and casing. Control panel is mounted into mechanical unit casing as a complete system that drives the arm movement. Casing is made with electroplated mild steel and finished with epoxy powder paint. The top cover and door on casing is cam locked (requires key) to avoid tampering with the internal system. The following is the parameter for complete system:

Description	Parameter
Mechanical temperature	-40° to 75 C
Electrical temperature	-10° to 75 C
Power supply input	220V ± 10% AC, 50/60Hz
Power consumption	80 watt - 1.25A @ 240V
Relative humidity	< 90 %
Arm speed	1 , 1.8, 3 , 6 second
Internal lubrication	Grease
Max starting torque	Max torque : 1 second : 1.4±0.2 N.M 3 / 6 second : 2.1 ± 0.1 N.M
AC rotation speed	AC rotation speed :1 second : 900 ± 50 RPM 3/6 second : 460 ± 40 RPM

Built in spring mechanism to counter balance arm's weight allow for effortless motor drive and longer mechanical life span.

Control panel

Consist of advance intelligent microprocessor based board and transformer housed in a weather resistant plastic casing. It controls the operation of the barrier system.



Function:

- Support 4 types of speed - 1 ,1.8, 3 , and 6 second
- Support separate push button for opening , closing and stop
- Support motor encoder sensor
- Support traffic light (red - green) output AC230
- Optical slot sensor to control up and down limit

Casing is made from weather proof ABS plastic.
Casing dimension: 211mm x 95mm x 118mm

Barrier arm

Arm is made of octagon aluminum hollow. There are 4 standard lengths available: 3m, 4m, 4.5m or 6m depend on barrier gate model. Other customized length is also available upon request. Red reflective adhesive is put onto the arm alternately for better visual during night time.

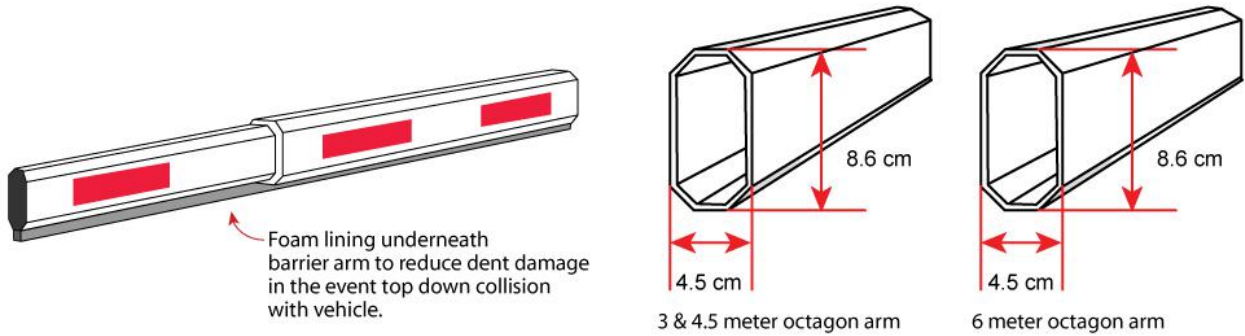

Typical installation diagram - with access control system

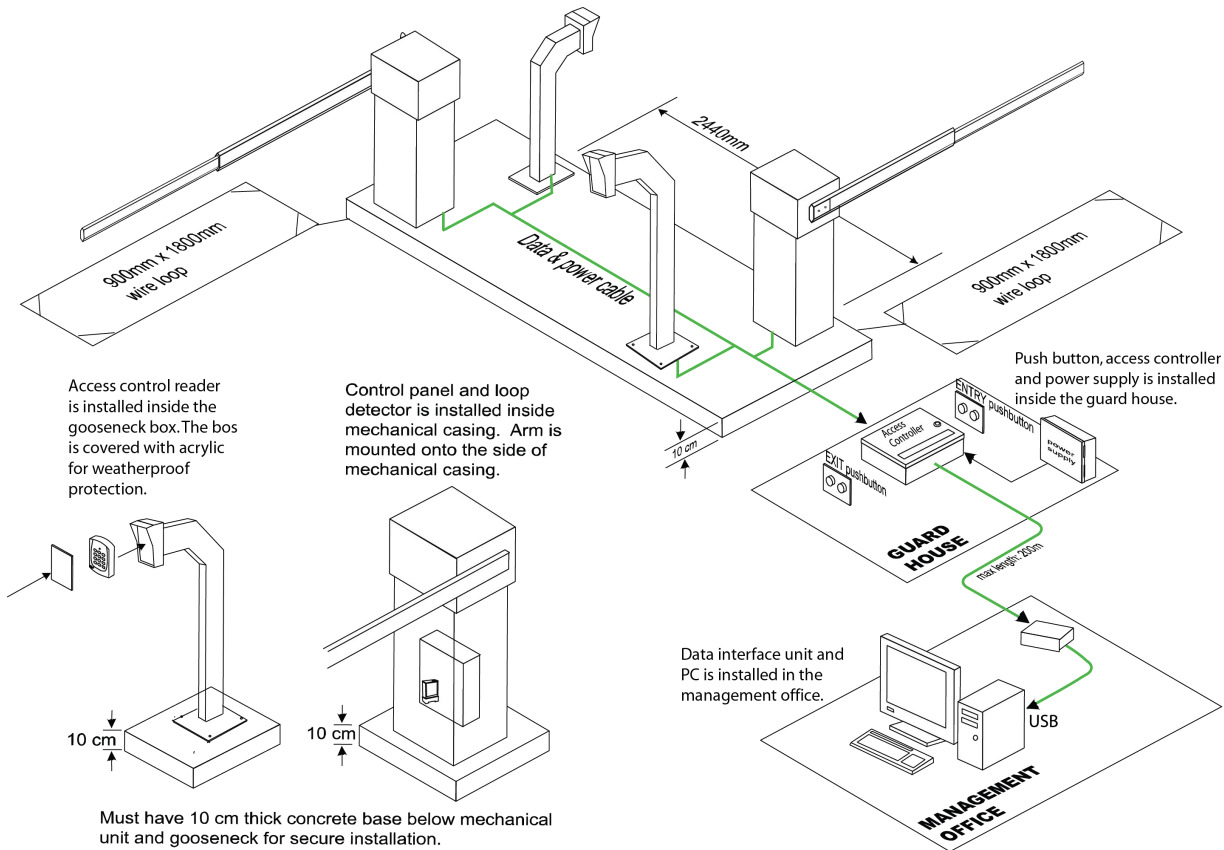

****Diagram is for illustration only and does NOT reflect actual installation. Actual installation dimension varies depending on site.**

Dimension drawing

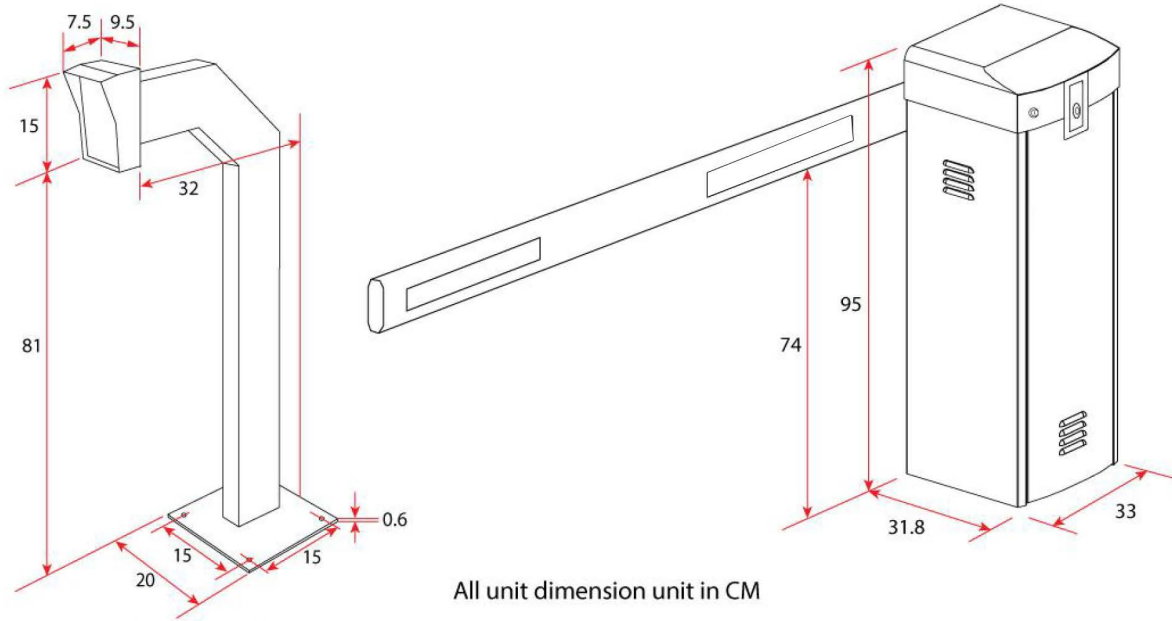

Ordering information

Ordering code:

Model No.	Open/close Speed	Max arm length	Arm swing out
BR618T	1.8 sec	4 meter	Yes
BR630T	3 sec	4 meter	Yes
BR660T	6 sec	6 meter	No
GSSD	MAG Gooseneck		

Left Side Arm	BR618TL, BR630TL, BR660TL
Right Side Arm	BR618TR, BR630TR, BR660TR

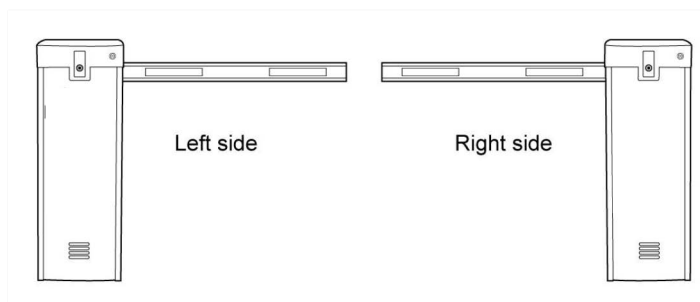

Packaging information

Standard color body is gray, top cover is dark gray in color. A complete system consists of:

- 1 pcs Standard AC 230 Motor
- 1 pcs Control panel and MCB switch
- 1 set Aluminum Arm
- 2 pcs U bracket for base mounting
- 4 pcs Raw bolt screw

The following is the approximate weight information of major components to help estimate shipping cost.

Items	Weight
Mechanical unit and control panel	65 kg
Gooseneck	9 kg
6 meter arm	7 kg
4 meter arm	5 kg
3 meter arm	3 kg

Optional accessories

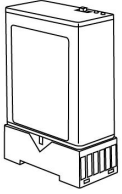

Single channel loop detector. Detect presence of vehicle.

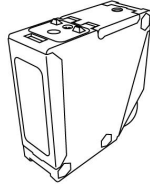

Safety IR beam sensor. Detect obstacle in barrier path and auto reverse barrier arm for extra safety

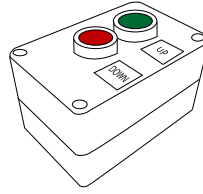

Heavy duty push button for manual open and close.

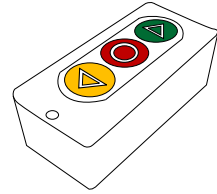

Light usage push button for manual open, stop and close.

Authorized dealer:

Disclaimers

Applications that are described herein for any of these products are for illustrative purposes only. Drawing does not necessary reflect exact assembly/installation. AST makes no representation or warranty that such applications will be suitable for the specified use without further testing or modification.

AST reserves the right to make changes, without notice, in the products, including circuits, standard cells, and/or software, described or contained herein in order to improve design and/or performance. AST assumes no responsibility or liability for the use of any of these products, conveys no license or title under any patent, copyright, or masks work right to these products, and makes no representations or warranties that these products are free from patent, copyright, or mask work right infringement, unless otherwise specified