

Heat proof compact design hydraulic cylinders usable at high temperatures

- Heat proof hydraulic cylinders usable at ambient temperatures up to 150°C. Switch Set Cylinders provided with heat proof sensors SW013 can be used at temperatures up to 130°C.
- A wide variety of heat proof compact design hydraulic cylinders having bores from 32 to 80 mm and mounting styles SD, LD, FA and FB.
- The mounting pitch is the same as that of general purpose type 160S-1 Series. (The overall length is larger by 10 mm.)
- For bearings and sealing parts, special copper alloy and fluorine-based material seals are adopted.



Standard Specifications

Type	Standard type	Switch Set
Nominal pressure	16 MPa	
Proof test pressure	24 MPa	
Minimum operating pressure	0.3 MPa	
Working speed range	1 to 100 mm/s	
Working temperature range	-10 to +150°C	-10 to +130°C
Structure of cushioning	None	
Adaptable fluid	Petroleum-based fluid and phosphate ester fluid	
Seal material	Fluoric plastic sliding ring+fluorocarbon O-ring	
Tolerance for thread	JIS 6H/6g	
Tolerance of stroke	0 to 0.8 mm	
Mounting style	SD·LD·FA·FB	
Rod end thread	Female thread, male thread	
Applicable sensor	-	SW013

Adaptability of Fluid to Seal Material

Seal material	Applicable fluid				
	Petroleum-based fluid	Water-glycol fluid	Phosphate ester fluid	Water in oil fluid	Oil in water fluid
Fluororesin sliding rings + Fluorocarbon O-rings	⊙	×	⊙	⊙	⊙

Note) ⊙: Applicable ×: Inapplicable

Terminologies

Nominal pressure

Pressure given to a cylinder for convenience of naming. It is not always the same as the working pressure (rated pressure) that guarantees performance under the specified conditions.

Maximum allowable pressure

Maximum allowable pressure generated in a cylinder (surge pressure, etc.).

Proof test pressure

Test pressure against which a cylinder can withstand without unreliable performance at the return to nominal pressure.

Minimum operating pressure

Minimum pressure at which cylinder installed horizontally operates under no load.

- Notes) ● This series of cylinders does not have air vents.
- Since lateral load (eccentric load) must not be applied to the piston rod, take care when installing the cylinder.
 - The working temperature range depends on the seal material.
 - For details, see the selection materials at the beginning of this catalog.
 - When the piston hits against the cylinder end face at the stroke end, reduce the speed to less than the minimum speed.

Product Lineup

Unit: mm

Series Variation	Type	Mounting Style	φ32	φ40	φ50	φ63	φ80
High-temperature type	Double acting single rod	Standard type HRST1	SD	●	●	●	●
			LD	●	●	●	●
	FA·FB	●	●	●	●		
	Switch Set HRST1R	SD	●	●	●	●	
		LD	●	●	●	●	
		FA·FB	●	●	●	●	

- Notes) ● When using a sensor, use a Switch Set Cylinder.
● No sensor can be mounted onto the standard type cylinder.

Double acting single rod



Standard type (HRST1)



Switch Set (HRST1R)

Weight Table: Standard type

Unit: kg

Bore mm	Basic style (SD)		Switch Set (SD)		Mounting accessory additional weight		Separate flange joint (M-end)	Male thread additional weight
	Basic weight	Additional weight per mm of stroke	Basic weight	Additional weight per mm of stroke	Flange type FA·FB	Foot type LD		
φ32	1.70	0.025	1.47	0.022	062	1.09	0.3	0.057
φ40	2.18	0.030	1.96	0.028	1.16	1.42	0.4	0.114
φ50	2.99	0.037	2.68	0.036	1.60	2.43	0.6	0.201
φ63	4.45	0.047	3.96	0.049	2.02	3.30	0.8	0.435
φ80	7.57	0.067	7.20	0.071	3.77	5.86	1.4	0.798

Sensor Additional Weight Table

Unit: kg

Heat proof reed sensor (cord length 1.5 m)	
SW013	0.05

Calculation formula Cylinder weight (kg)=basic weight+(cylinder stroke (mm)×additional weight per mm of stroke)+(sensor additional weight×sensor quantity)

Calculation example HRST1R, bore φ40, cylinder stroke 50 mm, 2 pcs of SW013
1.96+(50×0.028)+(0.05×2)=3.46kg

Piston Pressure Receiving Area Table

Unit: mm²

Bore	Rod dia.	Double acting single rod	
		Extension side	Retraction side
φ32	φ18	804	550
φ40	φ22	1257	876
φ50	φ28	1963	1348
φ63	φ36	3117	2100
φ80	φ45	5027	3436

Calculation formula $F=A \cdot P \cdot \beta$ (N)

F: cylinder force (N) A: piston pressure receiving area (mm²)
P: working pressure (MPa) β: load rate

Calculation example

Double acting single rod, bore φ40, working pressure: 16 MPa, load rate: 0.8
Cylinder force on extension side (N)
=1257×16×0.8=16090 (N)
Cylinder force on retraction side (N)
=876×16×0.8=11213 (N)

● How to order

General Purpose Type

The item enclosed by broken line needs not to be entered, if unnecessary. Semi-standard

● Standard type **HRST1** 3 SD 40 N 30 T G - L - V

● Switch Set **HRST1R** 3 SD 40 N 30 T G DH 2 - L - V

Fluorine-based material

SD Basic style
LD Foot type
FA Rod flange
FB Cap flange

φ32-φ40-φ50-φ63-φ80
 No cushion
 Cylinder stroke (mm)

None Without air vent (standard)
V With air vents

With one lock nut
 Note) Available only for male thread type

Sensor quantity (1, 2)

DH Heat proof sensor

Notes on ordering Switch Set

- When no sensor is required, specify 0 for the sensor symbol and the sensor quantity.
- Sensors are not mounted on cylinders at delivery.

None Rc thread
G G thread

Note) G thread is applicable only to the SD style.

 Female thread type (No entry for standard type)
T Male thread type

★ Lock nut number for ordering

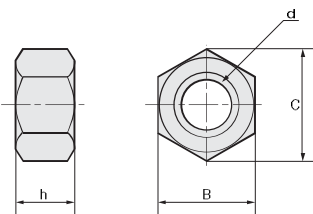

★ Port G thread type (only for SD style)

● Please specify the code as following.
 (Example) HRST1 3SD63N30-G
 Port G thread type

Note) The port G thread has dimensions different from the standard dimensions depending on the bore.
 Refer to the dimensional tables.

Dimensional Table

Unit: mm

Bore	Part number	d	B	C	h
φ20	LNH-16F-H	M16X1.5	22	25.4	10
φ40	LNH-20F-H	M20X1.5	27	31.2	12
φ50	LNH-24F-H	M24X1.5	32	37.0	14
φ63	LNH-30F-H	M30X1.5	41	47.3	17
φ80	LNH-39F-H	M39X1.5	55	63.5	20

★ Air vent specifications (order made)

The air vents are laid on the port surface and located symmetrical positions to the ports.

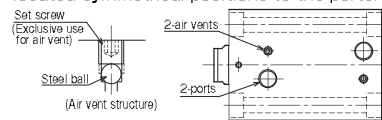

(Structure)

Applicable to: Single rod
 SD/LA/FA/FB style

Sensor List

Type	Sensor symbol	Load voltage range	Load current range	Max. switching capacity	Protective circuit	Indicating lamp	Wiring method	Cord length	Applicable load
Heat proof	DH SW013	DC: 30 V or less AC: 120 V or less	DC: 40 mA or less AD: 20 mA or less	DC: 1.5W AC: 2VA	None	None	0.3 mm ² , 2-core, outer dia. φ3.9 mm Heat proof silicone cable cord	1.5 m	IC circuit, small relay, programmable controller

Notes) ● For the sensors without a protective circuit, be sure to provide a protective circuit (SK-100) with the load when using any induction load (relay, etc.).
 ● For handling of sensors, be sure to see the sensor specifications at the end of this catalog.

Heat proof sensor

SW013 (rear wiring)



Sensor Mountable Minimum Stroke Unit: mm

Bore	With one sensor	With two sensors
φ32	5	10
φ40		
φ50		
φ63		
φ80		

Operating Range and Hysteresis Unit: mm

Bore	Operating range	Hysteresis
φ32	10 to 17	2 or less
φ40		
φ50		
φ63		
φ80		

Note) ● When two sensors are used on one surface at a stroke of 10 mm, adjust their positions because they may interfere with each other.

Standard Stroke Range

Series variation	Type	Bore	Cylinder stroke (mm)													Male thread type			
			5	10	15	20	25	30	35	40	50	60	70	80	90		100		
Double acting single rod	Standard type HRST1	φ32	○	○	○	○	○	○	○	○	○	○	○	○	○	○	□	○	
		φ40	○	○	○	○	○	○	○	○	○	○	○	○	○	○	○	□	○
		φ50	○	○	○	○	○	○	○	○	○	○	○	○	○	○	○	□	○
	Switch Set HRST1R	φ63	○	○	○	○	○	○	○	○	○	○	○	○	○	○	○	□	○
		φ80	○	○	○	○	○	○	○	○	○	○	○	○	○	○	○	□	○
		φ32	○	○	○	○	○	○	○	○	○	○	○	○	○	○	○	□	○
		φ40	○	○	○	○	○	○	○	○	○	○	○	○	○	○	□	○	
		φ50	○	○	○	○	○	○	○	○	○	○	○	○	○	○	□	○	
		φ63	○	○	○	○	○	○	○	○	○	○	○	○	○	○	□	○	
		φ80	○	○	○	○	○	○	○	○	○	○	○	○	○	○	□	○	

○: Standard range □: Semi-standard range (The leadtime varies depending on the bore and stroke. For details, contact us.)

Heat Resisting Compact Hydraulic Cylinders

HRST1

Heat Resisting Compact Hydraulic Cylinders

HRST1

SD

HRST1 3 SD Bore N Stroke T

None: Female thread type
T : Male thread type

- Bore $\phi 32$ to $\phi 80$
Heat proof: 150°C

- Male thread type

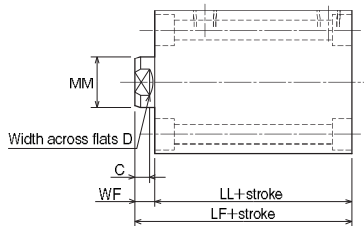
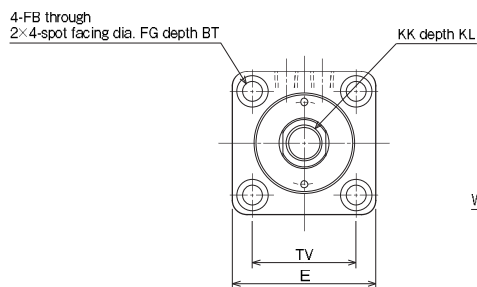
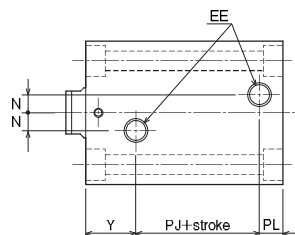
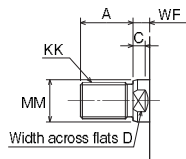
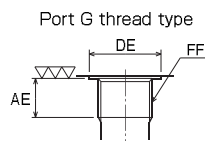

CAD/DATA is available.

HRST1/THRST1 Bore

Dimensional Table

Symbol Bore	A	AE	BT	C	D	DE	E	EE	FB	FF	FG	KK		KL
												Female thread type	Male thread type	
$\phi 32$	25(40)	8	6.5	7	14	$\phi 17.2$	$\square 62$	Rc1/4	$\phi 6.6$	G1/8	$\phi 11$	M12 X 1.75	M16 X 1.5	15
$\phi 40$	30(45)	8	8.6	7	19	$\phi 17.2$	$\square 70$	Rc1/4	$\phi 9$	G1/8	$\phi 14$	M16 X 2	M20 X 1.5	20
$\phi 50$	35(50)	12	10.8	8	24	$\phi 21.5$	$\square 80$	Rc1/4	$\phi 11$	G1/4	$\phi 17.5$	M20 X 2.5	M24 X 1.5	24
$\phi 63$	45(60)	12	13	9	30	$\phi 21.5$	$\square 94$	Rc1/4	$\phi 14$	G1/4	$\phi 20$	M27 X 3	M30 X 1.5	33
$\phi 80$	60(80)	12	15.2	14	41	$\phi 21.5$	$\square 114$	Rc3/8	$\phi 16$	G1/4	$\phi 23$	M30 X 3.5	M39 X 1.5	36

Symbol Bore	LF	LL	MM	N		PJ		PL		TV	WF	Y	
				Rc thread	G thread	Rc thread	G thread	Rc thread	G thread			Rc thread	G thread
$\phi 32$	64	64	$\phi 18$	10	10	19	19	12	12	$\square 47$	10	33	33
$\phi 40$	65	65	$\phi 22$	10	10	26	26	12	12	$\square 52$	10	27	27
$\phi 50$	71	70	$\phi 28$	10	14	29	23.5	13	18.5	$\square 58$	11	28	28
$\phi 63$	80	77	$\phi 36$	10	16	34	30	13	17	$\square 69$	13	30	30
$\phi 80$	95	88	$\phi 45$	15	19	35	34	18	18	$\square 86$	17	35	36

- Notes) ● When the lock nut is used, the parenthesized dimension A is recommended. (Order made)
 ● The lock nut needs to be ordered separately.
 ● The tolerance of MM is f8.

CAD/DATA
is available.

HRST1/THRST1 is available.

LD

HRST1 3 LD N

None: Female thread type
 : Male thread type

- Bore $\phi 32$ to $\phi 80$
Heat proof: 150°C
- Male thread type

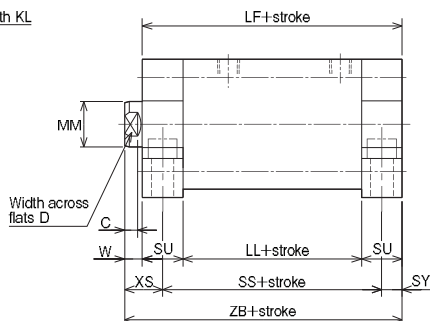
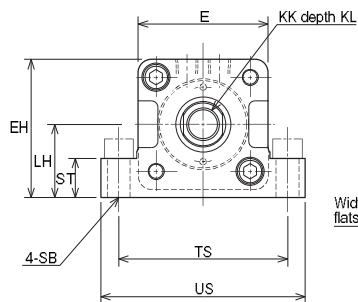
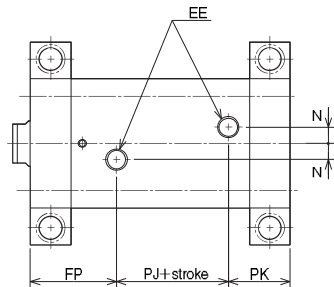
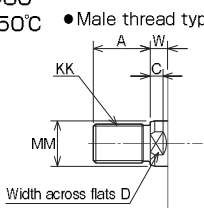

*When installing the cylinder on the grounding surface, be sure to use hex. socket head cap screws.

Dimensional Table

Symbol Bore	A	C	D	E	EE	EH	FP	KK		KL	LF	LH
								Female thread type	Male thread type			
$\phi 32$	25(40)	7	14	$\square 62$	Rc1/4	66	53	M12×1.75	M16×1.5	15	104	35±0.15
$\phi 40$	30(45)	7	19	$\square 70$	Rc1/4	72.5	47	M16×2	M20×1.5	20	105	37.5±0.15
$\phi 50$	35(50)	8	24	$\square 80$	Rc1/4	85	53	M20×2.5	M24×1.5	24	120	45±0.15
$\phi 63$	45(60)	9	30	$\square 94$	Rc1/4	97	55	M27×3	M30×1.5	33	127	50±0.15
$\phi 80$	60(80)	14	41	$\square 114$	Rc3/8	117	65	M30×3.5	M39×1.5	36	148	60±0.25

Symbol Bore	LL	MM	N	PJ	PK	SB	SS	ST	SU	SY	TS	US	W	XS	ZB
$\phi 32$	64	$\phi 18$	10	19	32	9	84	16	20	10	79	94	10	20	114
$\phi 40$	65	$\phi 22$	10	26	32	11	85	20	20	10	90	108	10	20	115
$\phi 50$	70	$\phi 28$	10	29	38	14	95	24	25	12.5	104	126	11	23.5	131
$\phi 63$	77	$\phi 36$	10	34	38	16	102	30	25	12.5	121	146	13	25.5	140
$\phi 80$	88	$\phi 45$	15	35	48	18	118	35	30	15	144	172	17	32	165

- Notes) • When the lock nut is used, the parenthesized dimension A is recommended. (Order made)
 • The lock nut needs to be ordered separately.
 • The tolerance of MM is f8.

HRST1/THRST1 [Bore] CAD/DATA is available.

FA

HRST1 3 FA [Bore] N [Stroke] [T]

None: Female thread type
[T] : Male thread type

- Bore $\phi 32$ to $\phi 80$
Heat proof: 150°C
- Male thread type

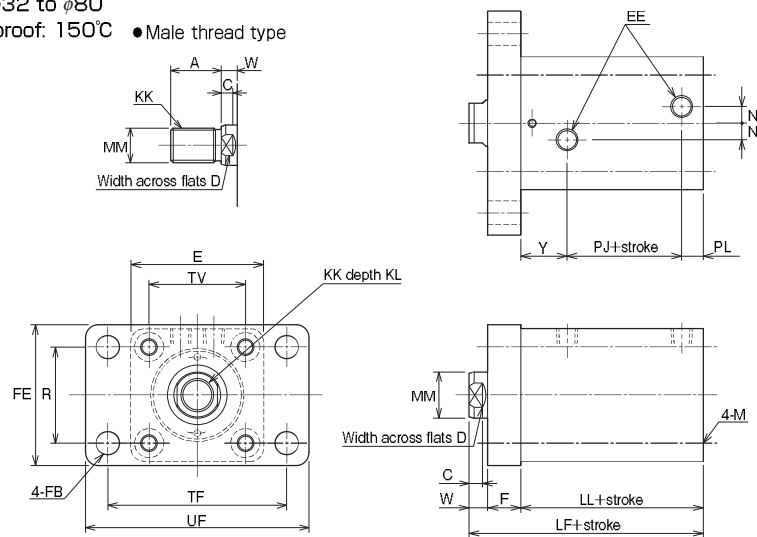

Dimensional Table

Symbol Bore	A	C	D	E	EE	F	FB	FE	KK		KL	LF
									Female thread type	Male thread type		
$\phi 32$	25(40)	7	14	$\square 62$	Rc1/4	15	$\phi 6.6$	62	M12×1.75	M16×1.5	15	89
$\phi 40$	30(45)	7	19	$\square 70$	Rc1/4	20	$\phi 11$	70	M16×2	M20×1.5	20	95
$\phi 50$	35(50)	8	24	$\square 80$	Rc1/4	20	$\phi 14$	85	M20×2.5	M24×1.5	24	101
$\phi 63$	45(60)	9	30	$\square 94$	Rc1/4	20	$\phi 14$	98	M27×3	M30×1.5	33	110
$\phi 80$	60(80)	14	41	$\square 114$	Rc3/8	25	$\phi 18$	118	M30×3.5	M39×1.5	36	130

Symbol Bore	LL	M	MM	N	PJ	PL	R	TF	TV	UF	W	Y
$\phi 32$	64	M6×1	$\phi 18$	10	19	12	40	80	$\square 47$	95	10	33
$\phi 40$	65	M8×1.25	$\phi 22$	10	26	12	46	96	$\square 52$	118	10	27
$\phi 50$	70	M10×1.5	$\phi 28$	10	29	13	58	108	$\square 58$	135	11	28
$\phi 63$	77	M12×1.75	$\phi 36$	10	34	13	65	124	$\square 69$	150	13	30
$\phi 80$	88	M14×2	$\phi 45$	15	35	18	87	154	$\square 86$	185	17	35

- Notes) ● When the lock nut is used, the parenthesized dimension A is recommended. (Order made)
 ● The lock nut needs to be ordered separately.
 ● The tolerance of MM is f8.

HRST1/THRST1 [Bore] CAD/DATA is available.

FB

HRST1 3 FB [Bore] N [Stroke] T

None: Female thread type
T : Male thread type

- Bore $\phi 32$ to $\phi 80$
Heat proof: 150°C
- Male thread type

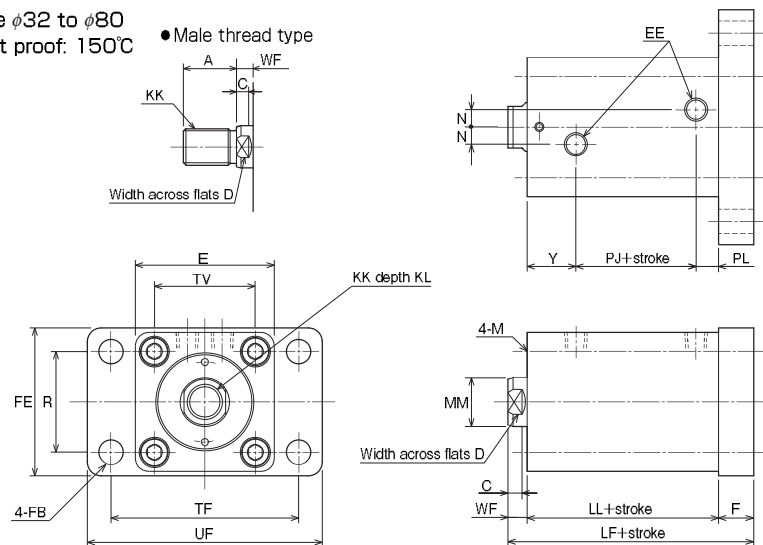

Dimensional Table

Symbol Bore	A	C	D	E	EE	F	FB	FE	KK		KL	LF
									Female thread type	Male thread type		
$\phi 32$	25(40)	7	14	$\square 62$	Rc1/4	15	$\phi 6.6$	62	M12×1.75	M16×1.5	15	89
$\phi 40$	30(45)	7	19	$\square 70$	Rc1/4	20	$\phi 11$	70	M16×2	M20×1.5	20	95
$\phi 50$	35(50)	8	24	$\square 80$	Rc1/4	20	$\phi 14$	85	M20×2.5	M24×1.5	24	101
$\phi 63$	45(60)	9	30	$\square 94$	Rc1/4	20	$\phi 14$	98	M27×3	M30×1.5	33	110
$\phi 80$	60(80)	14	41	$\square 114$	Rc3/8	25	$\phi 18$	118	M30×3.5	M39×1.5	36	130

Symbol Bore	LL	M	MM	N	PJ	PL	R	TF	TV	UF	WF	Y
$\phi 32$	64	M6×1	$\phi 18$	10	19	12	40	80	$\square 47$	95	10	33
$\phi 40$	65	M8×1.25	$\phi 22$	10	26	12	46	96	$\square 52$	118	10	27
$\phi 50$	70	M10×1.5	$\phi 28$	10	29	13	58	108	$\square 58$	135	11	28
$\phi 63$	77	M12×1.75	$\phi 36$	10	34	13	65	124	$\square 69$	150	13	30
$\phi 80$	88	M14×2	$\phi 45$	15	35	18	87	154	$\square 86$	185	17	35

- Notes) ●When the lock nut is used, the parenthesized dimension A is recommended. (Order made)
 ●The lock nut needs to be ordered separately.
 ●The tolerance of MM is f8.

SD

HRST1R 3 SD Bore N Stroke T Sensor symbol Sensor quantity

CAD/DATA is available.

None: Female thread type
 : Male thread type

- Bore $\phi 32$ to $\phi 80$
Heat proof: 130°C

• Port G thread type

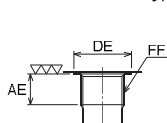

• Male thread type

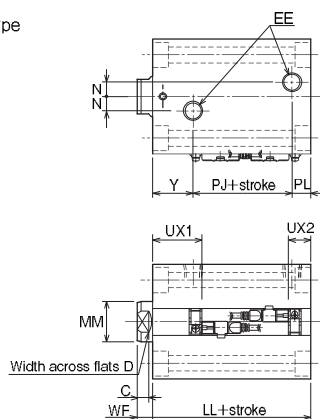
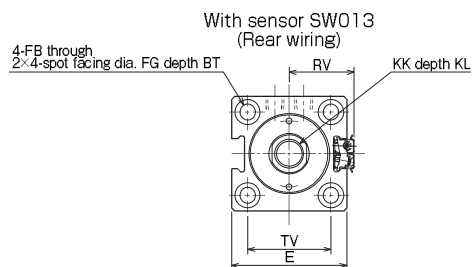
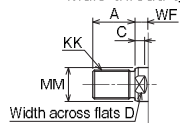

Dimensional Table

Symbol Bore	A	AE	BT	C	D	DE	E	EE	FB	FF	FG	KK		KL
												Female thread type	Male thread type	
$\phi 32$	25(40)	8	6.5	7	14	$\phi 17.2$	$\square 62$	Rc1/4	$\phi 6.6$	G1/8	$\phi 11$	M12 X 1.75	M16 X 1.5	15
$\phi 40$	30(45)	8	8.6	7	19	$\phi 17.2$	$\square 70$	Rc1/4	$\phi 9$	G1/8	$\phi 14$	M16 X 2	M20 X 1.5	20
$\phi 50$	35(50)	12	10.8	8	24	$\phi 21.5$	$\square 80$	Rc1/4	$\phi 11$	G1/4	$\phi 17.5$	M20 X 2.5	M24 X 1.5	24
$\phi 63$	45(60)	12	13	9	30	$\phi 21.5$	$\square 94$	Rc1/4	$\phi 14$	G1/4	$\phi 20$	M27 X 3	M30 X 1.5	33
$\phi 80$	60(80)	12	15.2	14	41	$\phi 21.5$	$\square 114$	Rc3/8	$\phi 16$	G1/4	$\phi 23$	M30 X 3.5	M39 X 1.5	36

Symbol Bore	LL	MM	N		PJ		PL		RV	TV	UX1	UX2	WF	Y	
			Rc thread	G thread	Rc thread	G thread	Rc thread	G thread						Rc thread	G thread
$\phi 32$	64	$\phi 18$	10	10	19	19	12	12	37	$\square 47$	29	17	10	33	33
$\phi 40$	65	$\phi 22$	10	10	26	26	12	12	41	$\square 52$	29	19	10	27	27
$\phi 50$	70	$\phi 28$	10	14	29	23.5	13	18.5	46	$\square 58$	31	22	11	28	28
$\phi 63$	77	$\phi 36$	10	16	24	30	13	17	53	$\square 69$	34	26	13	30	30
$\phi 80$	88	$\phi 45$	15	19	35	34	18	18	63	$\square 86$	39	31	17	35	36

- Notes) • When the lock nut is used, the parenthesized dimension A is recommended. (Order made)
 • The lock nut needs to be ordered separately.
 • The tolerance of MM is f8.

HRST1/THRST1 [Bore] CAD/DATA is available.

LD

HRST1R 3 LD [Bore] N [Stroke] T [Sensor symbol] [Sensor quantity]

None: Female thread type
T : Male thread type

- Bore $\phi 32$ to $\phi 80$
Heat proof: 130°C

● Male thread type

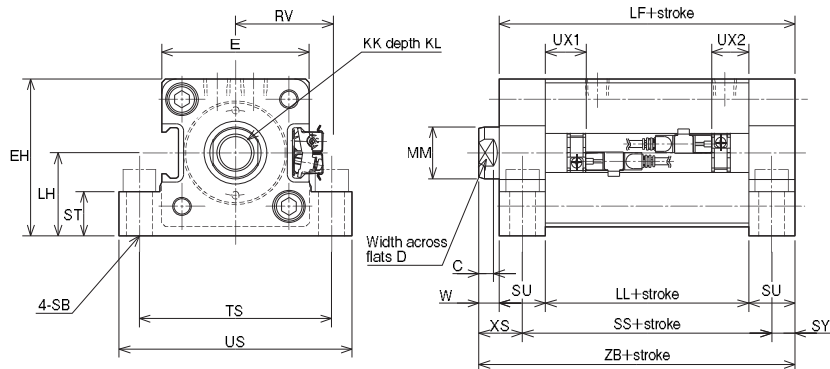
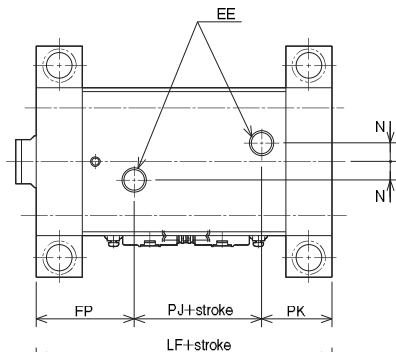
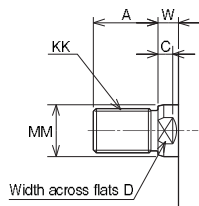

Dimensional Table

Symbol Bore	A	C	D	E	EE	EH	FP	KK		KL	LF	LH	LL
								Female thread type	Male thread type				
$\phi 32$	25(40)	7	14	$\square 62$	Rc1/4	66	53	M12×1.75	M16×1.5	15	94	35±0.15	64
$\phi 40$	30(45)	7	19	$\square 70$	Rc1/4	72.5	47	M16×2	M20×1.5	20	95	37.5±0.15	65
$\phi 50$	35(50)	8	24	$\square 80$	Rc1/4	85	53	M20×2.5	M24×1.5	24	110	45±0.15	70
$\phi 63$	45(60)	9	30	$\square 94$	Rc1/4	97	55	M27×3	M30×1.5	33	117	50±0.15	77
$\phi 80$	60(80)	14	41	$\square 114$	Rc3/8	117	65	M30×3.5	M39×1.5	36	138	60±0.25	88

Symbol Bore	MM	N	PJ	PK	RV	SB	SS	ST	SU	SY	TS	US	UX1	UX2	W	XS	ZB
$\phi 32$	$\phi 18$	10	19	32	37	9	84	16	20	10	79	94	29	17	10	20	114
$\phi 40$	$\phi 22$	10	26	32	41	11	85	20	20	10	90	108	29	19	10	20	115
$\phi 50$	$\phi 28$	10	29	38	46	14	95	24	25	12.5	104	126	31	22	11	23.5	131
$\phi 63$	$\phi 36$	10	34	38	53	16	102	30	25	12.5	121	146	34	26	13	25.5	140
$\phi 80$	$\phi 45$	15	35	48	63	18	118	35	30	15	144	172	39	31	17	32	165

- Notes) ● When the lock nut is used, the parenthesized dimension A is recommended. (Order made)
 ● The lock nut needs to be ordered separately.
 ● The tolerance of MM is f8.

*When installing the cylinder on the grounding surface, be sure to use hex. socket head cap screws.

CAD/DATA is available.

HRST1/THRST1 is available.

FA

HRST1R 3 FA

None: Female thread type
 : Male thread type

- Bore $\phi 32$ to $\phi 80$
Heat proof: 130°C
- Male thread type

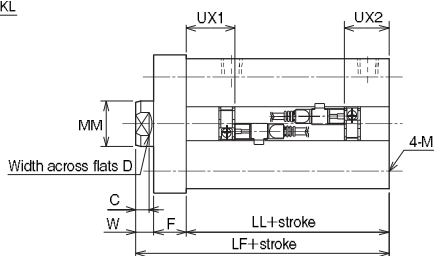
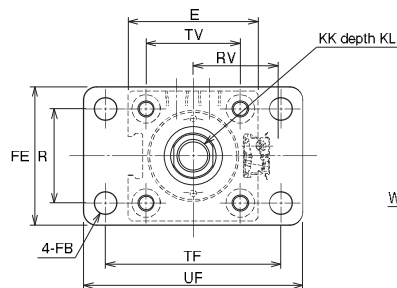
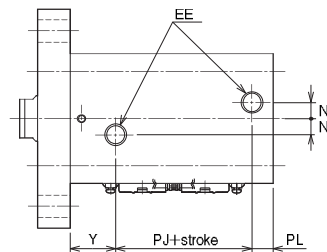
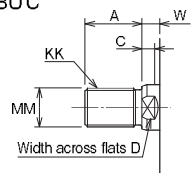

Dimensional Table

Symbol Bore	A	C	D	E	EE	F	FB	FE	KK		KL	LF	LL	M
									Female thread type	Male thread type				
$\phi 32$	25(40)	7	14	$\square 62$	Rc1/4	15	$\phi 6.6$	62	M12×1.75	M16×1.5	15	79	64	M6×1
$\phi 40$	30(45)	7	19	$\square 70$	Rc1/4	20	$\phi 11$	70	M16×2	M20×1.5	20	85	65	M8×1.25
$\phi 50$	35(50)	8	24	$\square 80$	Rc1/4	20	$\phi 14$	85	M20×2.5	M24×1.5	24	91	70	M10×1.5
$\phi 63$	45(60)	9	30	$\square 94$	Rc1/4	20	$\phi 14$	98	M27×3	M30×1.5	33	100	77	M12×1.75
$\phi 80$	60(80)	14	41	$\square 114$	Rc3/8	25	$\phi 18$	118	M30×3.5	M39×1.5	36	120	88	M14×2

Symbol Bore	MM	N	PJ	PL	R	RV	TF	TV	UF	UX1	UX2	W	Y
$\phi 32$	$\phi 18$	10	19	12	40	37	80	$\square 47$	95	29	17	10	33
$\phi 40$	$\phi 22$	10	26	12	46	41	96	$\square 52$	118	29	19	10	27
$\phi 50$	$\phi 28$	10	29	13	58	46	108	$\square 58$	135	31	22	11	28
$\phi 63$	$\phi 36$	10	34	13	65	53	124	$\square 69$	150	34	26	13	30
$\phi 80$	$\phi 45$	15	35	18	87	63	154	$\square 86$	185	39	31	17	35

- Notes:
- When the lock nut is used, the parenthesized dimension A is recommended. (Order made)
 - The lock nut needs to be ordered separately.
 - The tolerance of MM is f8.

HRST1/THRST1 [Bore] CAD/DATA is available.

FB

HRST1R 3 FB [Bore] N [Stroke] T [Sensor symbol] [Sensor quantity]

None: Female thread type
 : Male thread type

- Bore $\phi 32$ to $\phi 80$
Heat proof: 130°C
- Male thread type

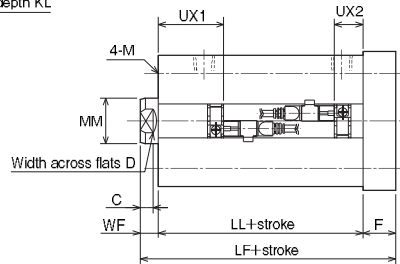
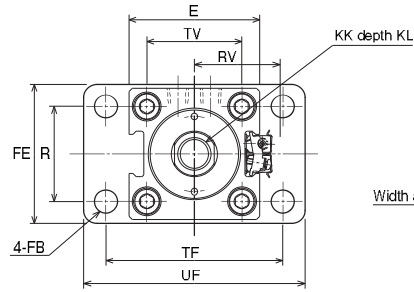
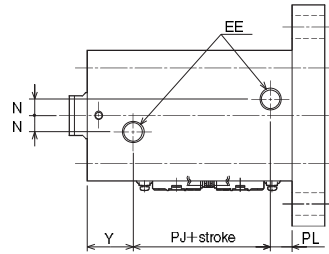
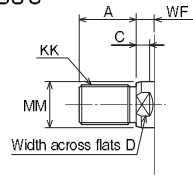

Dimensional Table

Symbol Bore	A	C	D	E	EE	F	FB	FE	KK		KL	LF	LL	M
									Female thread type	Male thread type				
$\phi 32$	25(40)	7	14	$\square 62$	Rc1/4	15	$\phi 6.6$	62	M12×1.75	M16×1.5	15	79	64	M6×1
$\phi 40$	30(45)	7	19	$\square 70$	Rc1/4	20	$\phi 11$	70	M16×2	M20×1.5	20	85	65	M8×1.25
$\phi 50$	35(50)	8	24	$\square 80$	Rc1/4	20	$\phi 14$	85	M20×2.5	M24×1.5	24	91	70	M10×1.5
$\phi 63$	45(60)	9	30	$\square 94$	Rc1/4	20	$\phi 14$	98	M27×3	M30×1.5	33	100	77	M12×1.75
$\phi 80$	60(80)	14	41	$\square 114$	Rc3/8	25	$\phi 18$	118	M30×3.5	M39×1.5	36	120	88	M14×2

Symbol Bore	MM	N	PJ	PL	R	RV	TF	TV	UF	UX1	UX2	WF	Y
$\phi 32$	$\phi 18$	10	19	12	40	37	80	$\square 47$	95	29	17	10	33
$\phi 40$	$\phi 22$	10	26	12	46	41	96	$\square 52$	118	29	19	10	27
$\phi 50$	$\phi 28$	10	29	13	58	46	108	$\square 58$	135	31	22	11	28
$\phi 63$	$\phi 36$	10	34	13	65	53	124	$\square 69$	150	34	26	13	30
$\phi 80$	$\phi 45$	15	35	18	87	63	154	$\square 86$	185	39	31	17	35

- Notes) • When the lock nut is used, the parenthesized dimension A is recommended. (Order made)
 • The lock nut needs to be ordered separately.
 • The tolerance of MM is f8.

Separate flange joint (M-end): Only for rod end shape A82

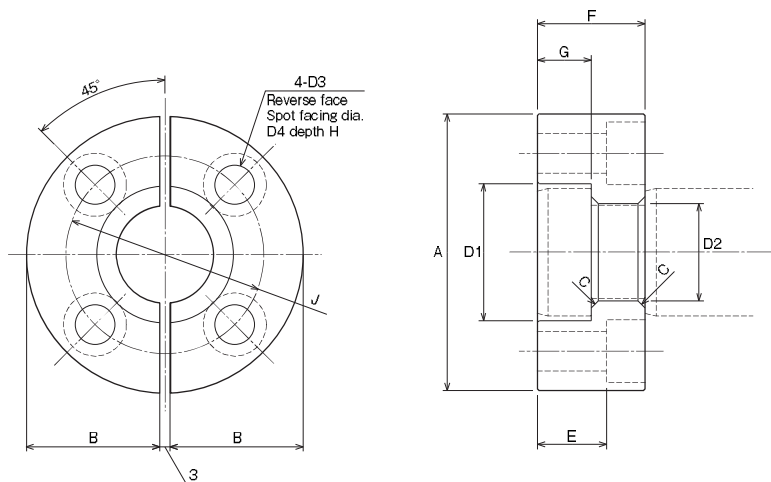

● Additional order must be made for this item. Specify as RMH-**.

Dimensional Table

Symbol Bore	Part number	A	B	C	D1	D2	D3	D4	E	F	G	H	J
φ32	RMH-18	φ49	23	1	φ19	φ13.5	φ6.6	φ11	18.5	25	12.5	6.5	φ34
φ40	RMH-22	φ57	27	1.5	φ23	φ16.5	φ9	φ14	16.4	25	12.5	8.6	φ40
φ50	RMH-28	φ71	34	1.5	φ29	φ21.5	φ11	φ17.5	14.2	25	12.5	10.8	φ50
φ63	RMH-36	φ77	37	2	φ38	φ27	φ11	φ17.5	19.2	30	15	10.8	φ55
φ80	RMH-45	φ100	48.5	2	φ48	φ33	φ14	φ20	17	30	15	13	φ76

Setting method of sensor detecting position

Tightening torque of bracket screw for sensor SW013
Approx. 0.4 N·m

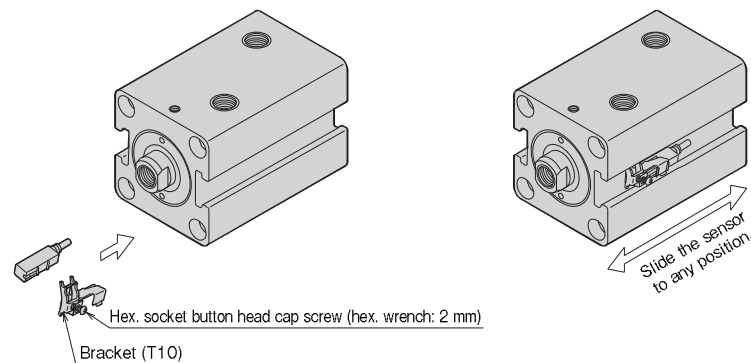

1. Loosen the bracket screw, and fit the bracket in the center of the sensor.
2. Insert the sensor combined with the bracket into the sensor mounting part of the cylinder body.
3. Slide the sensor to any position. Installing in the center of operating range provides the most stable detection.
4. To detect the cylinder stroke end, mount the sensor at dimension UX (optimum setting position).
5. After sliding the sensor to the detecting position, tighten the bracket screw.

Note) Inappropriate tightening torque may cause the off-center of the sensor position or damage to the sensor body.

How to order sensor only

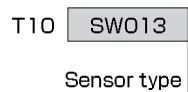

Precautions for use

- When using the cylinder with the rod push out, tighten the screw(s) to the rod end completely so that no load is applied to the piston rod screw section.
- Since lateral load (eccentric load) must not be applied to the piston rod, take care when installing the cylinder.
- When operating the cylinder for the first time, discharge air from the piping.
After discharging air, run the cylinder at a reduced pressure, and gradually increase the pressure to the working pressure.
Note) Since HRST1 Series has without air vents, discharge air from the piping.
- To install the cylinder, use four hex. socket head cap screws (JIS B1176, strength class 10.9 or more).
- When using mounting bolts, screw the bolts into mounting materials by 80% or more of the screw diameter. The mounting materials must have strength equal to SS400.
- When using nuts to tighten mounting bolts, use steel nuts with a strength class of 6 or more. (However, DO NOT use the type 3 nuts.)
- When using mounting bolts to secure the cylinder body, be sure to tighten them according to the following specified torque.

Cylinder Mounting Bolt Tightening Torque

Cylinder bore	Mounting bolt size	Tightening torque N·m
φ32	M6X1	8.1
φ40	M8X1.25	20.0
φ50	M10X1.5	40.0
φ63	M12X1.75	67.0
φ80	M14X2	110.0

Notes on disassembly and reassembly

- After removing the set screw, use the turning hole of the bush to remove the bush from the cylinder. When a jig is removed from the rod end screw, burrs may occur on the width across flats of the rod. Remove the burrs with a file, and remove the bush.
- The piston rod and piston cannot be disassembled.
- When reassembling the cylinder, be careful that foreign matters such as dust, fillings, and debris do not enter the inside of the cylinder.

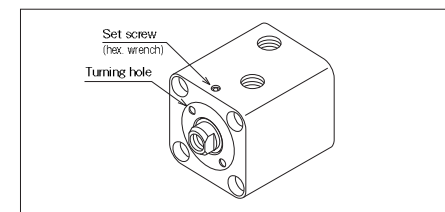

Note) A copper piece may be set under the set screw.

- When a copper piece is equipped under the set screw to protect the bush, remove it before tightening the bush.
- The center height of cylinders of the mounting style LD has been determined before shipment. When reassembling such a cylinder, adjust the center height.
- After tightening the bush;
In case of ①, place the copper piece under the set screw and tighten it.
In case of ②, tighten the set screw without placing the copper piece.

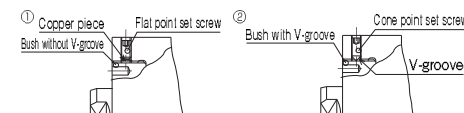

Combination of Copper Piece and Set Screw

No.	Screw on bush	Copper piece	Set screw type
①	Without V-groove	Required	Flat point
②	With V-groove	—	Cone point

Seal replacement

- When disassembling the cylinder, replace all seals (packing and gaskets).
- The piston seals, rod seals, dust wipers and bush O-rings of the standard type (HRST1) and Switch Set (HRST1R) cylinders are replaceable.
- Since the piston and rod have been locked, the piston rod O-ring cannot be replaced.
- Dimensions of bush turning hole

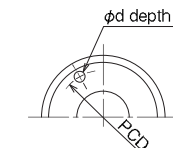

*Bore φ32 to φ80

Unit: mm

Bore	a	d	PCD
φ32	4.5	4	32
φ40	4.5	4	38
φ50	8	5	46
φ63	8	5	58
φ80	10	8	70