

02 | HYDRAULIC CYLINDER



Reference Data	[2] - 2
Standard Hydraulic Cylinder / KP140H	[2] - 8
High-Pressure Hydraulic Cylinder / KP210H	[2] - 29
Mill Type Hydraulic Cylinder / KPC70/140H	[2] - 42
High-Pressure Mill Type Hydraulic Cylinder / KPC210H	[2] - 53
Telescopic Cylinder / KTC70HP	[2] - 63
Steel Compact Cylinder / KP140HS	[2] - 76
Aluminium Compact Cylinder / KP125/160A	[2] - 83
Rotary Cylinder / KP35R	[2] - 88
Hydraulic Machinery Cylinder / KH	[2] - 92

Hydraulic Cylinder Selection Procedures

When selecting a hydraulic cylinder, the items below need to be decided.

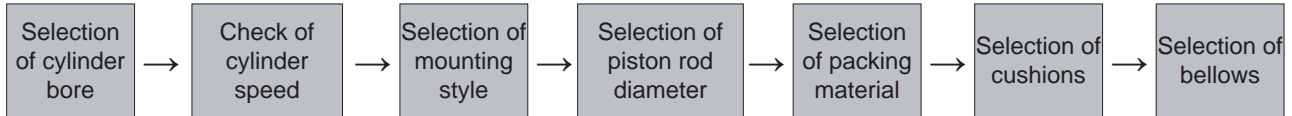

The items below need to be consider when selecting a hydraulic cylinder.

1. Set pressure (kgf/cm²): Set pressure of safety valve
2. Load (kgf): Weight of moving object
3. Condition of load : Mounting condition of load and applications
4. Cylinder required stroke (mm)
5. Operating speed (mm/sec)
6. Operating frequency (times/min) : Cycle/min
7. Application environment : Temperature, condition of dust, vibration and etc.

Selection of Cylinder Bore

The bore of a hydraulic cylinder depends on the required cylinder force.

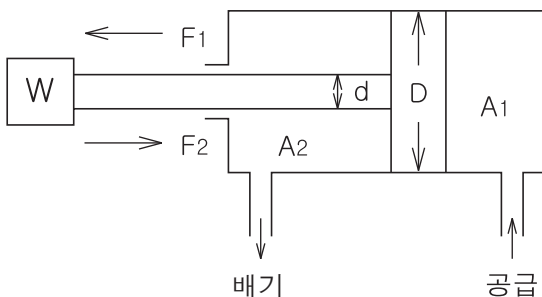

Push side cylinder force, $F_1 = A_1 \times P \times \beta$ (kgf)

Pull side cylinder force, $F_2 = A_2 \times P \times \beta$ (kgf)

(Unit : cm)

A_1 : Push side piston pressurized area(cm²)

A_2 : Pull side piston pressurized area (cm²)

D : Cylinder bore (cm) $A_1 = \frac{\pi}{4} D^2$

d : Diameter of piston rod (cm)

P : Operating pressure (kgf/cm²) $A_2 = \frac{\pi}{4} (D^2 - d^2)$

β : Load rate (%)

When deciding the actual cylinder output, the resistance in the cylinder slipping part and the pressure loss in the piping and machines must be considered.

The load rate is the ration of the actual force loaded onto the cylinder to the theoretical force (theroetical cylinder force) calculated from the circuit set pressure. The general set points are shown below.

For low speed working : 60~80%

For high speed working : 25~35%

(This catalogue is applying 80% as load rate in calculation.)

Example 1)

In the case of KP70/140H series with a 100mm cylinder bore and 70kgf/cm² pressure, Find the output of cylinder when piston is forwarding or reversing.

(Rod type: B type)

<Answer>

• Forward output (kgf)

$$= \text{Set pressure(kgf/cm}^2) \times \text{Forward piston pressurized area(cm}^2) \times \text{Load rate}$$

$$= 70 \times 78.54 \times 0.8 = 4,398.24(\text{kgf})$$

• Reverse output (kgf)

$$= \text{Set pressure(kgf/cm}^2) \times \text{Reverse piston pressurized area(cm}^2) \times \text{Load rate}$$

$$= 70 \times 54.78 \times 0.8 = 3,067.68(\text{kgf})$$

Example 2)

What is the diameter of cylinder in order to obtain the force of 5000kgf with the pressure of 70kgf/cm² by using KP70/140H?

<Answer>

• Piston pressurized area(cm²)

$$\begin{aligned} \text{Piston pressurized area (cm}^2) &= \frac{\text{Cylinder output(kgf)} \div \text{Load rate}}{\text{Set pressure (kgf/cm}^2)} \\ &= \frac{5000 \div 0.8}{70} \doteq 89.2(\text{cm}^2) \end{aligned}$$

Choose a piston pressurized area value which is near to 89.

Push side: Diameter 125mm

Pull side : Diameter of rod B 140mm
Diameter of rod C 125mm



Hydraulic Cylinder Theoretical Output Table

B type Rod Output Table (Load Rate 100%)

Bore size (mm)	Piston rod dia. (mm)	Operating direction	Effective sectional area (cm ²)	Output (kgf/cm ²)			Speed at flow rate of 10l/min (mm/sec)	Flow rate of speed of 10mm/sec (l/min)	Speed rate	
				70kgf/cm ²	140kgf/cm ²	210kgf/cm ²			Forward	Reverse
Ø40	Ø22	Forward	12.56	879	1,758	2,637	132.6	0.8	1	1.43
		Reverse	8.76	613	1,226	1,839	190.2	0.6		
Ø50	Ø28	Forward	19.63	1,374	2,748	4,122	84.9	1.2	1	1.46
		Reverse	13.47	942	1,885	2,828	123.7	0.8		
Ø63	Ø35	Forward	31.17	2,181	4,363	6,545	53.4	1.9	1	1.45
		Reverse	21.55	1,508	3,017	4,525	77.3	1.3		
Ø80	Ø45	Forward	50.26	3,518	7,036	10,554	33.1	3.0	1	1.47
		Reverse	34.36	2,405	4,810	7,215	48.5	2.1		
Ø100	Ø55	Forward	78.54	5,497	10,995	16,493	21.2	4.8	1	1.43
		Reverse	54.78	3,834	7,669	11,503	30.4	3.3		
Ø125	Ø70	Forward	122.71	8,589	17,179	25,769	13.5	7.4	1	1.46
		Reverse	84.23	5,896	11,792	17,688	19.7	5.1		
Ø140	Ø80	Forward	153.93	10,775	21,551	32,325	10.8	9.3	1	1.48
		Reverse	103.67	7,256	14,513	21,770	16.0	6.3		
Ø150	Ø85	Forward	176.71	12,369	24,739	37,109	9.4	10.6	1	1.47
		Reverse	119.97	8,397	16,795	25,193	13.58	7.2		
Ø160	Ø90	Forward	201.06	14,074	28,148	42,222	8.2	12.1	1	1.48
		Reverse	137.44	9,620	19,241	28,862	12.1	8.3		
Ø180	Ø100	Forward	254.46	17,812	35,624	53,436	6.5	15.3	1	1.45
		Reverse	175.92	12,314	24,628	36,943	9.4	10.6		
Ø200	Ø112	Forward	314.15	21,990	43,981	65,971	5.3	18.9	1	1.43
		Reverse	219.12	15,338	30,676	46,015	7.6	13.2		
Ø250	Ø140	Forward	490.87	34,360	68,721	103,082	3.3	29.5	1	1.48
		Reverse	336.93	23,585	47,170	70,755	4.9	20.3		

Hydraulic Cylinder
Reference Data
KP140H
KP210H
KPC70/140H
KPC210H
KTC70HP
KP140HS
KP125/160A
KP35R

C type Rod Output Table (Load Rate 100%)

Bore size (mm)	Piston rod dia. (mm)	Operating direction	Effective sectional area (cm ²)	Output (kgf/cm ²)			Speed at flow rate of 10l/min (mm/sec)	Flow rate of speed of 10mm/sec (l/min)	Speed rate	
				70kgf/cm ²	140kgf/cm ²	210kgf/cm ²			Forward	Reverse
Ø40	Ø18	Forward	12.56	439	879	1,758	132.6	0.8	1	1.25
		Reverse	10.02	350	701	1,402	166.3	0.6		
Ø50	Ø22	Forward	19.63	687	1,374	2,748	84.9	1.2	1	1.24
		Reverse	15.83	554	1,108	2,216	105.2	1.0		
Ø63	Ø28	Forward	31.17	1,090	2,181	4,363	53.4	1.9	1	1.25
		Reverse	25.01	875	1,750	3,501	66.6	1.5		
Ø80	Ø35	Forward	50.26	1,759	3,518	7,036	33.1	3.0	1	1.24
		Reverse	40.64	1,422	2,844	5,689	41.0	2.5		
Ø100	Ø45	Forward	78.54	2,748	5,497	10,995	21.2	4.8	1	1.23
		Reverse	62.63	2,192	4,384	8,768	26.1	3.8		
Ø125	Ø55	Forward	122.71	4,294	8,589	17,179	13.5	7.4	1	1.24
		Reverse	98.95	3,463	6,926	13,853	16.8	6.0		
Ø140	Ø65	Forward	153.93	5,387	10,775	21,551	10.8	9.3	1	1.22
		Reverse	125.66	4,398	8,796	17,592	13.2	7.6		
Ø150	Ø65	Forward	176.71	6,184	12,369	24,739	9.4	10.6	1	1.23
		Reverse	143.53	5,023	10,047	20,094	11.6	8.7		
Ø160	Ø70	Forward	201.06	7,037	14,074	28,148	8.2	12.1	1	1.24
		Reverse	162.57	5,689	11,379	22,759	10.2	9.8		
Ø180	Ø80	Forward	254.46	8,906	17,812	35,624	6.5	15.3	1	1.25
		Reverse	204.20	7,147	14,294	28,588	8.1	12.3		
Ø200	Ø90	Forward	314.15	10,995	21,990	43,981	5.3	18.9	1	1.25
		Reverse	250.54	87,68	17,537	35,075	6.6	15.1		
Ø250	Ø110	Forward	490.87	17,180	34,360	68,721	3.3	29.5	1	1.27
		Reverse	395.84	13,855	27,710	55,421	4.2	23.8		

KH

Selection of Piston Rod Diameter

When using hydraulic cylinder, user have to make considerations for compressive stress and buckling resulting from the cylinder strokes. As the use of high tension steel or heat treatment does not increase the hardness of piston rod, the only solution is to make the diameter of piston rod larger.

The buckling chart of piston rod indicates the maximum safe stroke based on the "Euler" formula when an optimum load is applied to each piston diameter. Stroke value have to be changed according to the condition of use like the case of special device of vertical, inclined or horizontal position or impact load. For example, user may increase the stroke by 1/3 when "guide" is enough by using the vertical cylinder, or apply 1/3 of the indicated value when impact load is given due to the horizontal installation of cylinder.

Calculation Method of Cylinder Buckling

How to calculate the maximum available load depending upon the diameter of cylinder.

1. Determine the type of the cylinder mounting (Figure 1~16 on next page)
2. Calculate "L" value
3. Find the maximum available load with "L" value and relevant diameter from the cylinder buckling chart.

Example) In case of CA type KP 140H series with a 1000mm stroke, Ø50 cylinder bore and rod B. Find the max. available load.

<Solution>

1. As both ends of cylinder are free axes, ①TYPE L=D
2. Calculate "L" value when stroke is known (refer to the dimensions in the catalogue)
 $L=D=(230+70+1000+1000)=2300\text{mm}$ Note)70 is the size of joint
3. From the buckling chart of KP 70/140H, you can get the answer W=250kg or less.

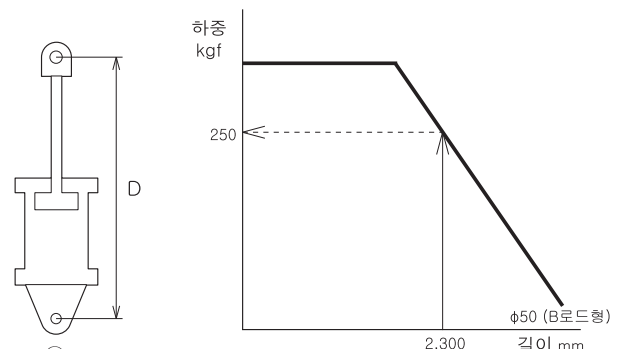

How to calculate the maximum stroke depending upon the cylinder bore size.

1. Determine the type of the cylinder mounting (Figure 1~16 on next page)
2. Find the "L" value with maximum available load and relevant diameter from the cylinder buckling chart.

Example) In case of FZ type KP 140H series with a Ø80 cylinder bore, 3500kg load and rod B. Find the max. stroke.

<Solution>

1. As one end of FZ type cylinder are free axes, ⑦TYPE L=2D
2. With W=3500kg and L=1500mm, find the stroke from the chart.
 $D=L/2=1500/2=(2 \times \text{stroke} + 243)$
Note) cylinder stroke on catalogue is approx. 253mm

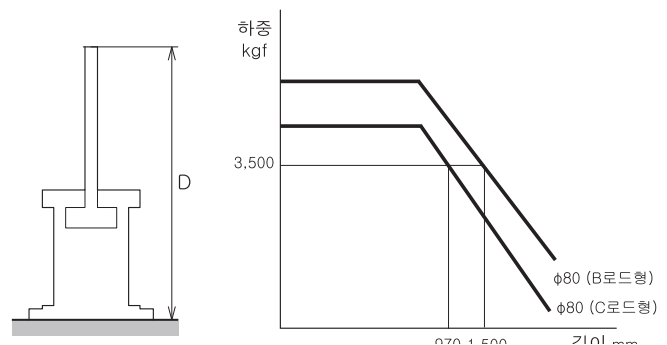

How to calculate the cylinder bore size depending upon the max. available load.

1. Determine the type of the cylinder mounting (Figure 1~16 on next page)
2. Calculate "L" value
3. Find the bore size with maximum available load and "L" value from the cylinder buckling chart.

Example) In case of FY type KP 140H series with 1000mm stroke, 3000kg load and free rod end. Find the bore size.

<Solution>

1. As one end of FY type cylinder are free axes, ⑤TYPE L=2D
2. $L=2D=2 \times (1000+100)=2200\text{mm}$ Note)100 is the length of rod
3. From the buckling chart, you can get the answer Rod B: Ø100, Rod C:Ø125.

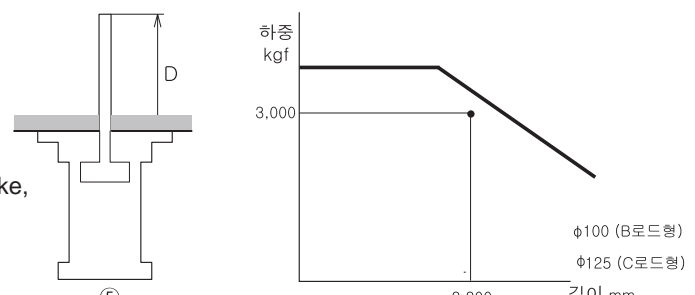

Buckling Chart by Cylinder Mounting Style

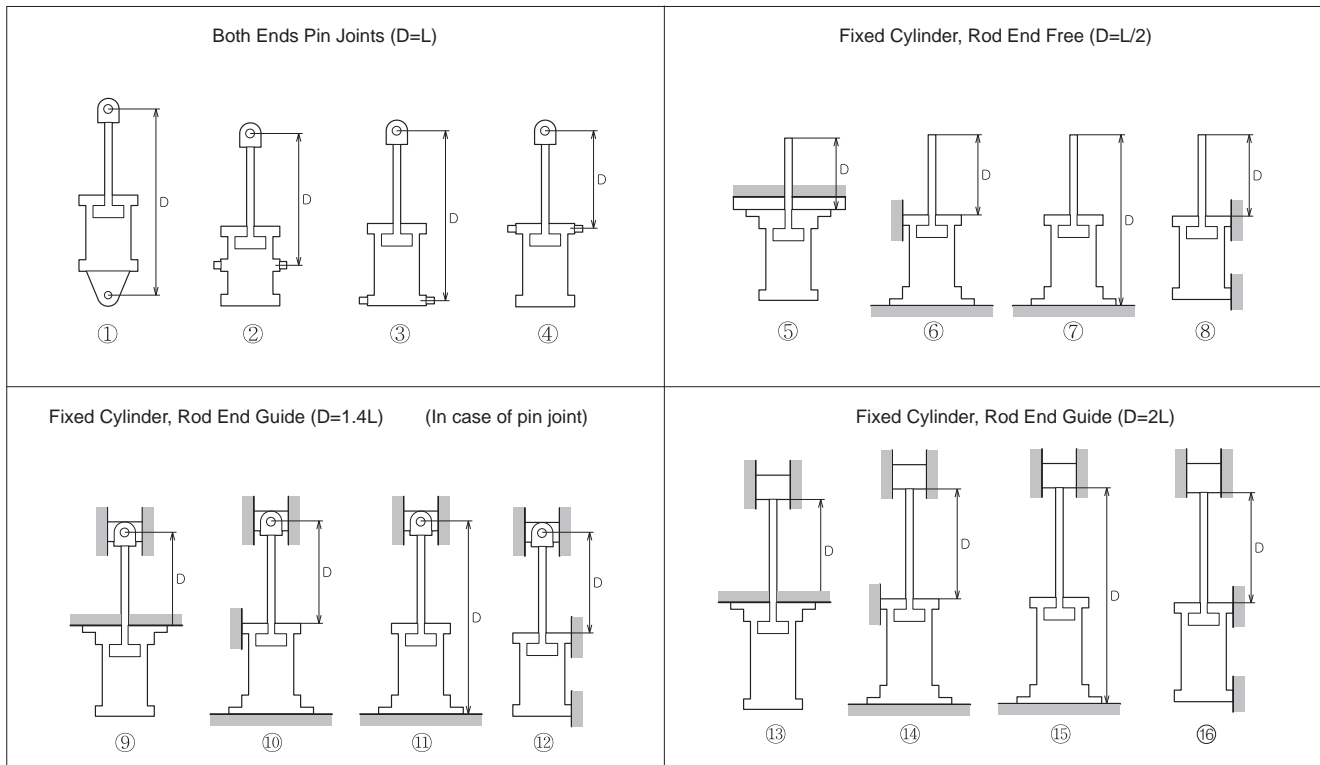

Hydraulic Cylinder
Reference Data
KP140H
KP210H
KPC70/140H
KPC210H
KTC70HP
KP140HS
KP125/160A
KP35R

Buckling Chart of Cylinder Rod

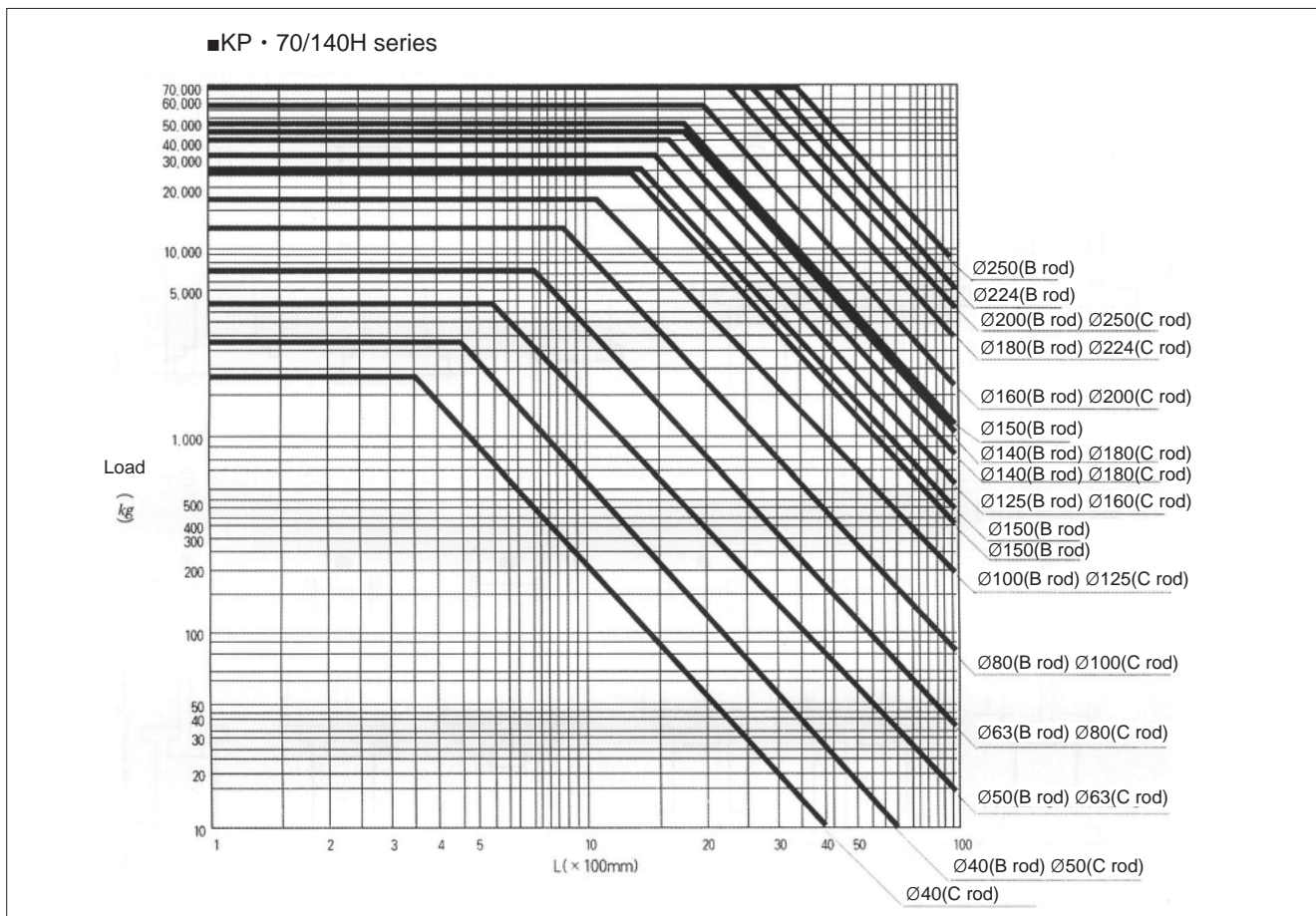

Notes on Piston Rod Buckling

Prior to the calculation of the piston rod buckling, consider the cylinder stopping method. The stopping methods of a cylinder include the cylinder stopping method, in which a cylinder is stopped at the stroke end, and the external stopping method, in which a cylinder is stopped with the external stopper. The definition of load differs depending on the selection of the stopping method as shown below.

Definition of a load when the cylinder stopping method is selected

Case ①	Case ②
	<p>The state of stopping at the cylinder stroke end as shown in the figure. For the load required for the buckling calculation, apply the formula below. For case ①: Load=W For case ②: Load=μW μ: Frictional coefficient</p>

Definition of a load when the external stopping method is selected

Case ①	Case ②
	<p>The state of halfway stopping with the external stopper as shown in the figure. The load required for the buckling calculation in this case is not the W, but the cylinder theoretical output (relief set pressure (kgf/cm²) x piston area (cm²))</p>

Adaptability of Packing Material to Working Oil

No.	Packing material	Applicable working oil				
		Petroleum-based fluid	Water-glycol fluid	Phosphate ester fluid	W/O fluid	O/W fluid
1	Nitrile Rubber	○	○	X	○	○
2	Urethane Rubber	◎	X	X	△	△
3	Fluoric Rubber	○	X	○	○	○

○/◎ = Applicable X = Inapplicable △ = Contact us
 ※ In case that the priority is given to the abrasion resistance, adopt the packing material of the ◎-marked combinations.

Working Temperature Range of Packing Material

No.	Packing material	Oil Temperature °C							
		-50	-10	0	50	80	100	120	150
1	Nitrile Rubber								
2	Urethane Rubber								
3	Fluoric Rubber								

Speed Range against Packing Material

Packing Material	Speed Range m/sec
Nitrile Rubber	8~500
Urethane Rubber	8~500
Fluoric Rubber	8~300

Packing Selection Criteria

Items	Urethane Rubber	Nitrile Rubber
Pressure resistance	◎ (Rate 2.5)	○ (Rate 1)
Abrasion resistance	◎	○
Life against change of ambient temperature	○	◎
Life against inferiority of working oil	○	◎
Oil leak from rod	◎	○
High use frequency under high pressure	◎	○
Low use frequency under low pressure	○	◎
Pull Strength (kgf/cm ²)	≥ 400	≥ 150
Elongation (%)	≥ 400	≥ 100
Hardness (HS)	90±5	85±5

Features of Urethane Rubber & Nitrile Rubber

Urethane Rubber

It has an excellent, pressure-resistant & abrasion-resistant, quality, for its tensile strength is 2.5 times as high as that of nitrile rubber. However, it needs to be overhauled and inspected every year because the quality of urethane rubber can deteriorate due to heat or the aging of oil in case of long-time use.

Nitrile Rubber

It is less affected by heat or by the aging of oil than urethane rubber. However, it is less pressure-resistant and abrasion-resistant because it has lower tensile strength than urethane rubber. Nitrile rubber is suitable for the case in which it is infrequently used at a low pressure without overhauling it for inspection for 2 or 3 years.

Check of Port Diameter Depending on Cylinder Speed

Cylinder speed depends on the quantity of oil fed into a cylinder.

$$\text{Cylinder speed, } V = 1.67 \times 10^4 \times Q_c / A$$

- V : Cylinder speed (mm/sec)
- Q_c : Oil quantity supplied into cylinder (ℓ/min)
- A : Pressurized area of piston(mm²)

The chart below shows the relation between the speed and the required flow rate for each size of standard hydraulic cylinders (cylinder inside) and that between the required flow rate and flow velocity in pipe for each port diameter.

<Example>

In the case of KP70/140H series with an 80mm cylinder bore and 300mm/s cylinder speed, is the standard port dia. applicable? Also, find the flow velocity in pipe.

<Answer>

In the chart below, find the cross point of the straight line from the point of 300mm/s cylinder speed and the slant line of 80mm cylinder bore, and draw a straight line parallel with lateral axis until it reaches the slant line of the port dia. 3/4 (the standard port dia. for the KP70/140H series with a cylinder bore of 80mm).

From the cross point on the slant port dia. line, draw a straight line parallel with the longitudinal axis until it reaches the lateral axis. From the cross point, the corresponding flow velocity in pipe is 5.2m/s.

Since the cross point, which is found based on the port dia. cylinder speed, and bore, is within the applicable working range, the standard port dia. is applicable.

Chart of Relation Between Cylinder Speed, Required Flow Rate, & Flow Velocity in Pipe

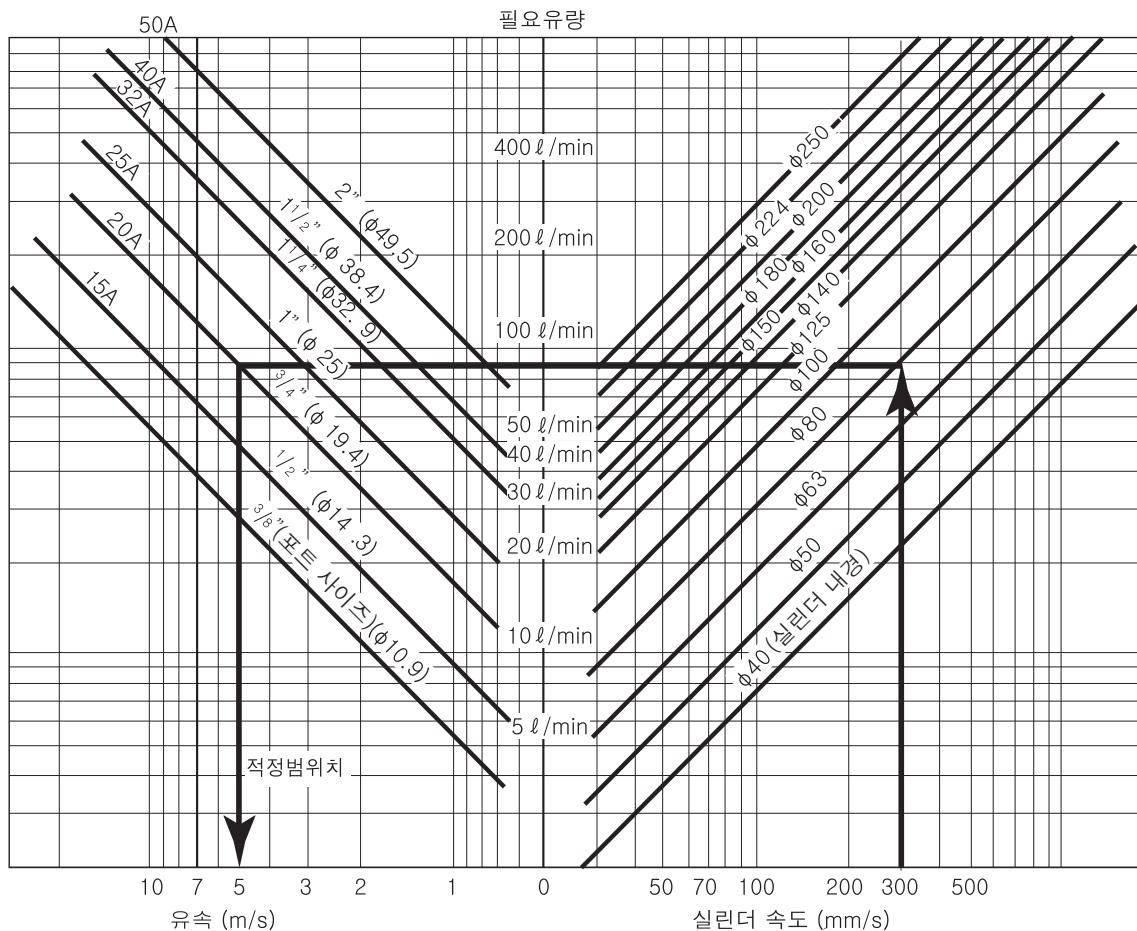

* The appropriate flow velocity in pipe for the appropriate range is 1m/s or less. In general, if the flow velocity in pipe exceeds 7m/s, the piping resistance and pressure loss are increased, causing less output during cylinder work and lower speed.

Standard Port Diameter

Series	Bore	Port Diameter Rc(PT)												
		40	50	63	80	100	125	140	150	160	180	200	224	250
KP-70/140H		3/8	1/2	1/2	3/4	3/4	1	1	1	1	1 1/4	1 1/2	1 1/2	2

- Hydraulic Cylinder
- Reference Data
- KP140H
- KP210H
- KPC70/140H
- KPC210H
- KTC70HP
- KP140HS
- KP125/160A
- KP35R
- KH

KP140H series



KP140HC-FA80C-N100 A B

KP140HLC-FY40B-N100 A B A54

Features

- Standard tie rod type hydraulic cylinder
- Double acting hydraulic cylinder for 70 kgf/cm² or 140kgf/cm² with bore sizes from Ø40 to Ø250.
- High performance cushion to reduce shock when stopping.
- Various mounting styles
(SD, LA, LB, FA, FB, FY, FZ, FC, FD, CA, CB, TC, TA)

Symbol

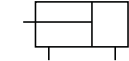

Double Acting / Single Rod

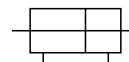

Double Acting / Double Rod

How to Order

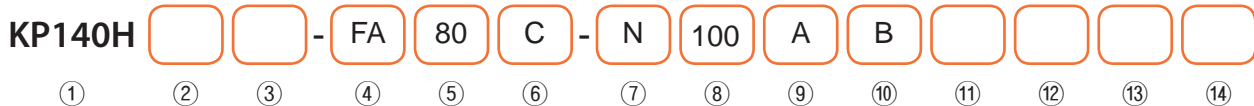

① Series

KP140H	Single rod
KP140H W	Double rod
KP140HL	With auto switch (Single rod)
KP140HL W	With auto switch (Double rod)

② Seal

C	Compact seal (Standard)
Nil	Basic seal
B	Booster seal

③ Seal Material

Nil	Nitrile Urethane (Standard)
1	Nitrile rubber
2	Urethane rubber
3	Fluoric rubber

※ The packing material of the compact seal is nitrile rubber.

④ Mounting style

140kgf/cm ²		70kgf/cm ²	
SD	Standard	LB	Axial foot
LA	Axial angle of foot	FA	Rod side rectangular flange
FY	Rod side rectangular flange	FB	Head side rectangular flange
FZ	Head side rectangular flange		
FC	Rod side square flange		
FD	Head side square flange		
CA	Single clevis		
CB	Double clevis		
TC	Center trunnion		
TA	Rod side trunnion		

⑤ Bore size

Bore size	B	C
40	Ø40	Ø22
50	Ø50	Ø28
63	Ø63	Ø35
80	Ø80	Ø45
100	Ø100	Ø55
125	Ø125	Ø70
140	Ø140	Ø80
150	Ø150	Ø85
160	Ø160	Ø90
180	Ø180	Ø100
200	Ø200	Ø112
250	Ø250	Ø140

⑥ Rod type

Bore size	B	C
40	Ø22	Ø18
50	Ø28	Ø22
63	Ø35	Ø28
80	Ø45	Ø35
100	Ø55	Ø45
125	Ø70	Ø55
140	Ø80	Ø65
150	Ø85	Ø65
160	Ø90	Ø70
180	Ø100	Ø80
200	Ø112	Ø90
250	Ø140	Ø112

⑦ Cushion

N	Without cushion
B	Cushions on both ends
R	Cushion on the rod side
H	Cushion on the head side

⑧ Cylinder stroke

Bore size	Max. stroke
Ø40, Ø50	1200
Ø63, Ø80	1600
Ø100	2000
Ø125~Ø250	2000

- ※ Check buckling, as it varies depending on mounting style.
- ※ Contact us for longer stroke.

⑨ Port position

A	Standard
B, C, D	Refer to the next figure

⑩ Cushion valve position

B	Standard
A, C, D	Refer to the next figure

⑪ Bellows

	Material	Max. ambient temperature
Nil	Without bellows	
J	Nylon Tarpaulin	60 °C
K	Neoprene Cloth	110 °C

⑫ Rod end attachment

Nil	Rod end nut (Standard)
I	Single knuckle joint
Y	Double knuckle joint

⑬ Auto switch

Reed A/S	Model	Solid state A/S	Model
A54	D-A54K	F59	D-F59K
A56	D-A56K	F5P	D-F5PK
A64	D-A64K	J59	D-J59K
A90(V)	D-A90(V)K	J51	D-J51K
A93(V)	D-A93(V)K	F9N	D-F9N(V)K
A96(V)	D-A96(V)K	F9P	D-F9P(V)K
		F9B	D-F9B(V)K

- ※ Only for single rod auto switch attached type.
- ※ For more information, refer to Auto Switch Catalogue.

⑭ Number of auto switch

Nil	2 pcs
1	1 pc
N	N pcs (N:3,4,5...)

- ※ Only for single rod auto switch attached type.

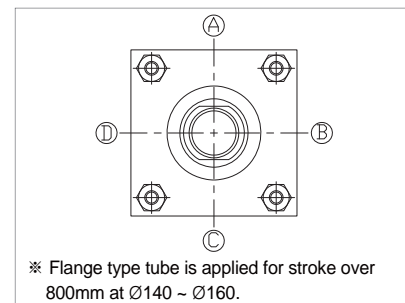



Specifications

Type	Standard		Auto switch attached			
	C Rod	B Rod	C Rod	B Rod		
Bore size	Ø40, Ø50, Ø63, Ø80, Ø100, Ø125, Ø140, Ø150, Ø160, Ø180, Ø200, Ø250		Ø40, Ø50, Ø63, Ø80, Ø100			
Operating pressure	70kgf/cm ² (7.0MPa)	140kgf/cm ² (14.0MPa)	70kgf/cm ² (7.0MPa)	140kgf/cm ² (14.0MPa)		
Max. operating pressure	Head side:90kgf/cm ² (9.0MPa) Rod side:110kgf/cm ² (11.0MPa)	Head side:180kgf/cm ² (18.0MPa) Rod side:180kgf/cm ² (18.0MPa)	Head side:90kgf/cm ² (9.0MPa) Rod side:110kgf/cm ² (11.0MPa)	Head side:180kgf/cm ² (18.0MPa) Rod side:180kgf/cm ² (18.0MPa)		
Proof pressure	105kgf/cm ² (10.5MPa)	210kgf/cm ² (21.0MPa)	105kgf/cm ² (10.5MPa)	210kgf/cm ² (21.0MPa)		
Min. operating pressure	Head side ≤3kgf/cm ² (0.3MPa), Rod side: B rod ≤4.5kgf/cm ² (0.45MPa), C rod ≤ 4kgf/cm ² (0.4MPa)					
Operating piston speed	Ø40 ~ Ø63 : 8~400mm/sec Ø80 ~ Ø125 : 8~300mm/sec Ø140 ~ Ø250 : 8~200mm/sec		Ø40 ~ Ø63 : 8~400mm/sec Ø80 ~ Ø100 : 8~300mm/sec			
Ambient & fluid temperature	-10 ~ 80℃		-10 ~ 70℃			
Cushion	Metal fitting type					
Working oil	Petroleum-based fluid					
Tolerance of thread	KS class 2					
Tolerance of stroke	≤100mm ^{+0.8} ₀	≤101~250mm ^{+1.0} ₀	≤251~630mm ^{+1.25} ₀	≤631~1000mm ^{+1.4} ₀	≤1001~1600mm ^{+1.6} ₀	≤1601~2000mm ^{+1.8} ₀
Tube material	Carbon steel for machine structural use			Stainless steel		
Mounting style	SD, LA, (LB), (FA), (FB), FY, FZ, FC, FD, CA, CB, TC, TA					

- * Operating pressure: Max. allowable setting pressure for a relief valve while cylinder is operating.
- * Max. operating pressure: Maximum allowable pressure generated in a cylinder (surge pressure, etc.).
- * Proof pressure: Test pressure for a cylinder can withstand without unreliable performance when returning to operating pressure.
- * Min. operating pressure: Minimum pressure for cylinder installed horizontally and operating without load.
- * Operating pressure for the mounting styles in () are 70kgf/cm².
- * A longer thread length (A) is required when lock nut is applied on the end of the piston rod.

Cushion Length

Unit:mm

Bore size	Ø40 ~ Ø63	Ø80 ~ Ø100	Ø125 ~ Ø150	Ø160	Ø180	Ø200	Ø250
Cushion length	22	25	30	35	40	45	50

Mounting Style

Bore size Mounting	Ø40	Ø50	Ø63	Ø80	Ø100	Ø125	Ø140	Ø150	Ø160	Ø180	Ø200	Ø250
Axial angle of foot	LA(Hyd.)40	LA(Hyd.)50	LA(Hyd.)63	LA(Hyd.)80	LA(Hyd.)100	LA(Hyd.)125	LA(Hyd.)140	LA(Hyd.)150	LA(Hyd.)160	LA(Hyd.)180	LA(Hyd.)200	LA(Hyd.)250
Axial foot	LB(Hyd.)40	LB(Hyd.)50	LB(Hyd.)63	LB(Hyd.)80	LB(Hyd.)100	LB(Hyd.)125	LB(Hyd.)140	LB(Hyd.)150	LB(Hyd.)160	LB(Hyd.)180	LB(Hyd.)200	LB(Hyd.)250
Flange	FA/FB (Hyd.)40	FA/FB (Hyd.)50	FA/FB (Hyd.)63	FA/FB (Hyd.)80	FA/FB (Hyd.)100	FA/FB (Hyd.)125	FA/FB (Hyd.)140	FA/FB (Hyd.)150	FA/FB (Hyd.)160	FA/FB (Hyd.)180	FA/FB (Hyd.)200	FA/FB (Hyd.)250
Reinforced square flange	FY/FZ (Hyd.)40	FY/FZ (Hyd.)50	FY/FZ (Hyd.)63	FY/FZ (Hyd.)80	FY/FZ (Hyd.)100	FY/FZ (Hyd.)125	FY/FZ (Hyd.)140	FY/FZ (Hyd.)150	FY/FZ (Hyd.)160	FY/FZ (Hyd.)180	FY/FZ (Hyd.)200	FY/FZ (Hyd.)250
Square flange	FC/FD (Hyd.)40	FC/FD (Hyd.)50	FC/FD (Hyd.)63	FC/FD (Hyd.)80	FC/FD (Hyd.)100	FC/FD (Hyd.)125	FC/FD (Hyd.)140	FC/FD (Hyd.)150	FC/FD (Hyd.)160	FC/FD (Hyd.)180	FC/FD (Hyd.)200	FC/FD (Hyd.)250
Single clevis	CA(Hyd.)40	CA(Hyd.)50	CA(Hyd.)63	CA(Hyd.)80	CA(Hyd.)100	CA(Hyd.)125	CA(Hyd.)140	CA(Hyd.)150	CA(Hyd.)160	CA(Hyd.)180	CA(Hyd.)200	CA(Hyd.)250
Double clevis	CB(Hyd.)40	CB(Hyd.)50	CB(Hyd.)63	CB(Hyd.)80	CB(Hyd.)100	CB(Hyd.)125	CB(Hyd.)140	CB(Hyd.)150	CB(Hyd.)160	CB(Hyd.)180	CB(Hyd.)200	CB(Hyd.)250
Trunnion	TA/TC (Hyd.)40	TA/TC (Hyd.)50	TA/TC (Hyd.)63	TA/TC (Hyd.)80	TA/TC (Hyd.)100	TA/TC (Hyd.)125	TA/TC (Hyd.)140	TA/TC (Hyd.)150	TA/TC (Hyd.)160	TA/TC (Hyd.)180	TA/TC (Hyd.)200	TA/TC (Hyd.)250
Double clevis pin	CB PIN (Hyd.)40	CB PIN (Hyd.)50	CB PIN (Hyd.)63	CB PIN (Hyd.)80	CB PIN (Hyd.)100	CB PIN (Hyd.)125	CB PIN (Hyd.)140	CB PIN (Hyd.)150	CB PIN (Hyd.)160	CB PIN (Hyd.)180	CB PIN (Hyd.)200	CB PIN (Hyd.)250

Rod End Attachment

Bore size		Ø40	Ø50	Ø63	Ø80	Ø100	Ø125	Ø140	Ø150	Ø160
Accessory	Single knuckle joint	I(Hyd.)40B	I(Hyd.)50B	I(Hyd.)63B	I(Hyd.)80B	I(Hyd.)100B	I(Hyd.)125B	I(Hyd.)140B	I(Hyd.)150B	I(Hyd.)160B
	C	I(Hyd.)40C	I(Hyd.)50C	I(Hyd.)63C	I(Hyd.)80C	I(Hyd.)100C	I(Hyd.)125C	I(Hyd.)140C	I(Hyd.)150C	I(Hyd.)160C
Double knuckle joint	B	Y(Hyd.)40B	Y(Hyd.)50B	Y(Hyd.)63B	Y(Hyd.)80B	Y(Hyd.)100B	Y(Hyd.)125B	Y(Hyd.)140B	Y(Hyd.)150B	Y(Hyd.)160B
	C	Y(Hyd.)40C	Y(Hyd.)50C	Y(Hyd.)63C	Y(Hyd.)80C	Y(Hyd.)100C	Y(Hyd.)125C	Y(Hyd.)140C	Y(Hyd.)150C	Y(Hyd.)160C
Double knuckle joint pin		Y PIN (Hyd.)40	Y PIN (Hyd.)50	Y PIN (Hyd.)63	Y PIN (Hyd.)80	Y PIN (Hyd.)100	Y PIN (Hyd.)125	Y PIN (Hyd.)140	Y PIN (Hyd.)150	Y PIN (Hyd.)160
Rod end nut		RN(Hyd.)40	RN(Hyd.)50	RN(Hyd.)63	RN(Hyd.)80	RN(Hyd.)100	RN(Hyd.)125	RN(Hyd.)140	RN(Hyd.)150	RN(Hyd.)160

Mass

Unit : kg

Bore size	Rod type	Basic mass (SD)		Mounting mass												Accessory mass		Additional mass for each 1mm of stroke	
		Standard type	Double rod type	LA	LB	FA	FB	FC	FD	FY	FZ	CA	CB	TA	TC	Single knuckle joint	Double knuckle joint	Standard type	Double rod type
Ø40	B	3.5	4.4	0.5	0.5	0.2	0.7	0.7	1.1	0.3	0.8	0.5	0.6	0.1	0.6	0.5	0.7	0.011	0.014
	C	3.4	4.3															0.010	0.012
Ø50	B	5.0	6.4	0.9	0.7	0.7	1.2	1.5	2.0	1.1	1.6	1.0	1.2	0.4	1.0	1.0	1.2	0.014	0.019
	C	4.9	6.2															0.012	0.014
Ø63	B	7.9	10.2	1.0	1.2	1.0	1.8	2.2	3.1	1.6	2.4	2.0	2.6	0.6	1.2	2.7	3.9	0.019	0.027
	C	7.6	9.8															0.017	0.022
Ø80	B	16.2	20.3	1.8	2.0	1.1	3.0	2.8	4.7	2.1	4.0	3.0	3.6	0.6	2.1	2.7	3.7	0.032	0.045
	C	15.5	19.4															0.027	0.035
Ø100	B	26.0	32.7	2.1	2.9	1.8	4.8	4.6	7.4	3.9	6.9	5.5	6.7	1.0	3.8	4.2	7.7	0.048	0.067
	C	24.9	31.1															0.042	0.055
Ø125	B	42.9	53.6	3.2	5.5	2.9	8.4	8.0	13.0	6.2	12.1	9.9	12.1	2.1	6.2	8.0	14.6	0.077	0.107
	C	42.5	52.7															0.065	0.084
Ø140	B	59.6	73.9	3.8	7.7	3.2	11.1	9.2	17.1	8.2	16.1	16.7	21.0	4.1	11.1	19.0	28.8	0.100	0.140
	C	56.0	69.6															0.085	0.111
Ø150	B	66.9	86.5	4.8	9.6	4.9	13.7	16.6	22.4	10.7	19.5	18.2	26.8	4.6	10.9	18.9	28.3	0.118	0.162
	C	67.9	83.6															0.101	0.127
Ø160	B	84.3	114.6	5.4	10.0	5.3	16.5	19.0	25.2	11.3	22.5	22.9	28.4	5.2	14.8	22.7	34.2	0.121	0.171
	C	79.9	99.1															0.102	0.132
Ø180	B	115.1	-	7.9	13.8	7.7	22.7	25.0	33.6	17.5	32.5	33.8	42.9	-	19.4	-	-	0.179	0.241
	C	108.5	-															0.157	0.197
Ø200	B	155.2	-	11.4	21.0	10.6	31.6	28.8	48.7	22.6	43.6	51.4	65.4	-	27.2	-	-	0.220	0.295
	C	147.3	-															0.192	0.242
Ø250	B	283.7	-	18.3	46.7	17.5	55.1	48.2	88.3	42.5	80.1	74.5	91.6	-	43.3	-	-	0.333	0.454
	C	264.1	-															0.290	0.365

Calculation:

Ex.) KP140H-LA80B-N200 A B
 Basic mass: 16.2 / Additional mass: 0.032 / Cylinder stroke: 200mm /
 LA type:1.8
 $16.2+(0.032 \times 200) + 1.8 = 24.4\text{kg}$

Structure-Ø40C~Ø63C

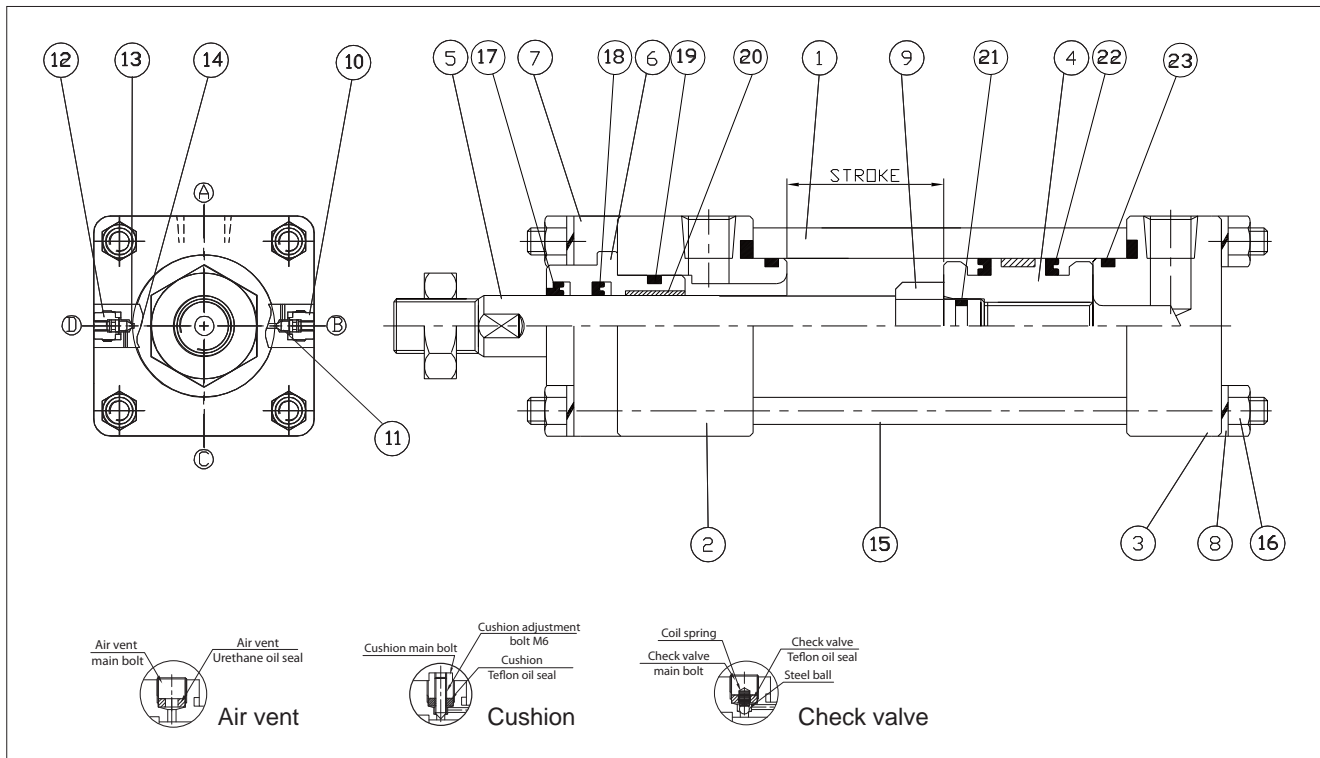

Hydraulic Cylinder
Reference Data
KP140H
KP210H
KPC70/140H
KPC210H
KTC70HP
KP140HS
KP125/160A
KP35R
KH

Part List

Part no.	Parts	Material	Quantity
1	Cylinder Tube	STKM13C	1
2	Rod Cover	SS400	1
3	Head Cover	SS400	1
4	Piston	SM45C	1
5	Piston Rod	SM45C	1
6	Bush	SM45C	1
7	Retainer (Bush Cover)	SS400	1
8	Spring Washer	SWRH57B	8

Part no.	Parts	Material	Quantity
9	Cushion Ring	SM45C	1
10	Cushion Body	SUM24L	2
11	Cushion Needle	SUM24L	2
12	Check Body	SUM24L	4
13	Coil Spring	SUP	4
14	Steel Ball	SUJ2	4
15	Tie Rod	SM45C	4
16	Hex Nut (2 Kinds)	SM45C	8

Packing List

Part no.	Parts	Ø40 (C)	Ø50 (C)	Ø63 (C)	Ø40 (B)	Ø50 (B)	Material	Quantity
17	Dust Seal	18×26×4.5×6	22×30×4.5×6	28×36×6	22×30×4.5×6	28×30×4.5×6	Urethane	1
18	Rod Packing	18×26×5	22×30×5	28×35.5×5	22×30×5	28×35.5×5	Urethane	1
19	Bush O-Ring	G-30	G-35	G-45	G-30	G-35	NBR	1
20	DU Bush	1820	2220	2820	2220	2820	SPCC	1
21	Rod O-Ring	P-14	P-18	P-22	P-14	P-18	NBR	1
22	Piston Packing	40×30×16.4	50×34×18.4	63×47×18.4	40×30×16.4	50×34×18.4	NBR	1
23	Tube O-Ring	G-35	G-35	G-58	G-35	G-35	NBR	2

Structure-Ø63B~Ø125B

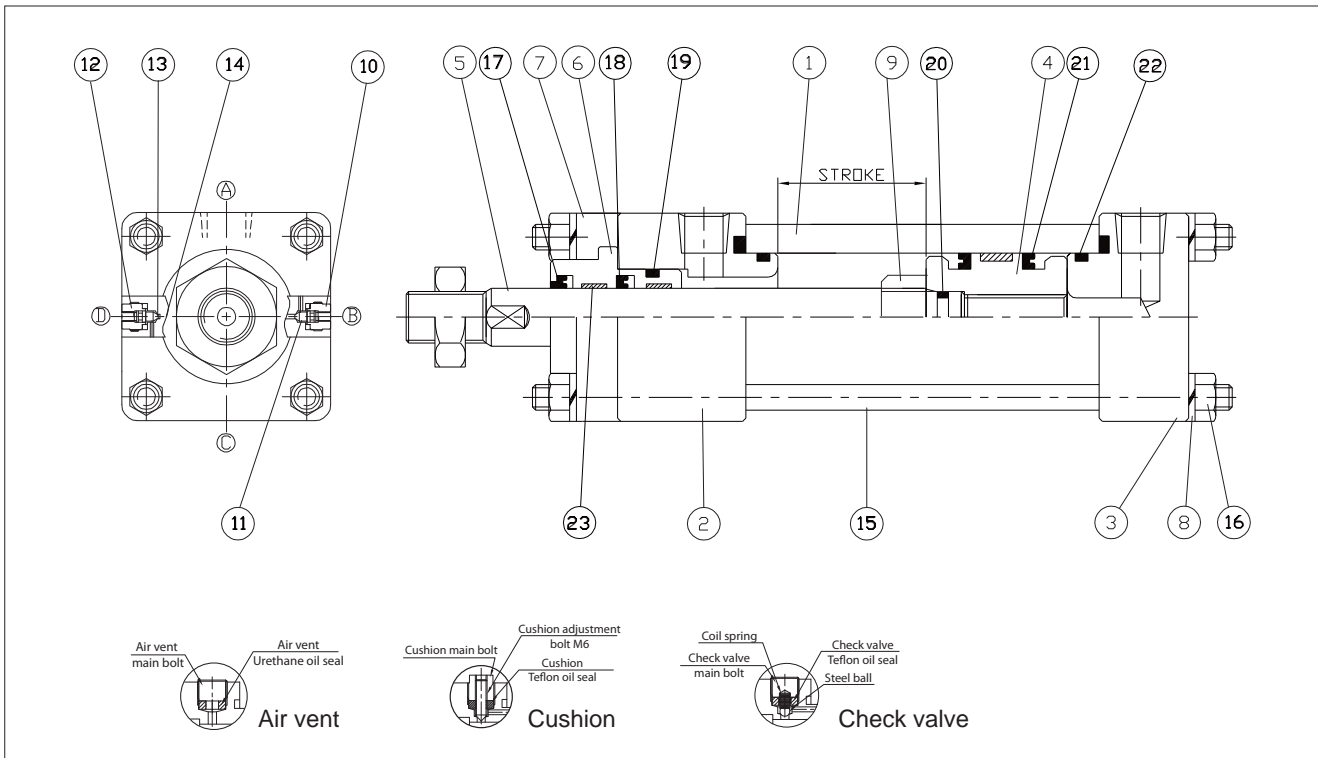

Part List

Part no.	Parts	Material	Quantity
1	Cylinder Tube	STKM13C	1
2	Rod Cover	SS400	1
3	Head Cover	SS400	1
4	Piston	SM45C	1
5	Piston Rod	SM45C	1
6	Bush	SM45C	1
7	Retainer (Bush Cover)	SS400	1
8	Spring Washer	SWRH57B	8

Part no.	Parts	Material	Quantity
9	Cushion Ring	SM45C	1
10	Cushion Body	SUM24L	2
11	Cushion Needle	SUM24L	2
12	Check Body	SUM24L	4
13	Coil Spring	SUP	4
14	Steel Ball	SUJ2	4
15	Tie Rod	SM45C	4
16	Hex Nut (2 Kinds)	SM45C	8

Packing List

Part no.	Parts	Ø80 (C)	Ø100 (C)	Ø125 (C)	Ø63 (B)	Ø80 (B)	Ø100 (B)	Ø125 (B)	Material	Qty.
17	Dust Seal	35×43×6.5	45×53×6×6.5	55×63×5/6.5	35×43×6.5	45×53×6.5	55×63×6×6.5	70×80×6/8	Urethane	1
18	Rod Packing	35×45×6	45×55×6	55×65×6	35×45×6	45×55×6	55×65×6	70×80×6	Urethane	1
19	Bush O-Ring	G-55	G-65	G-80	G-45	G-55	G-65	G-80	NBR	1
20	ROD O-Ring	P-29	G-50	G-50	P-22	P-29	G-50	G-50	NBR	1
21	Piston Packing	80×60×22.4	100×75×22.4	125×100×25.4	63×47×18.4	80×60×22.4	100×75×22.4	125×100×25.4	NBR	1
22	Tube O-Ring	G-75	G-95	G-120	G-58	G-75	G-95	G-120	NBR	2
23	Wearing	-	45×50×10	55×60×10	-	45×50×10	55×60×10	70×75×10	Phenol	2

Structure-Ø140C~Ø250B

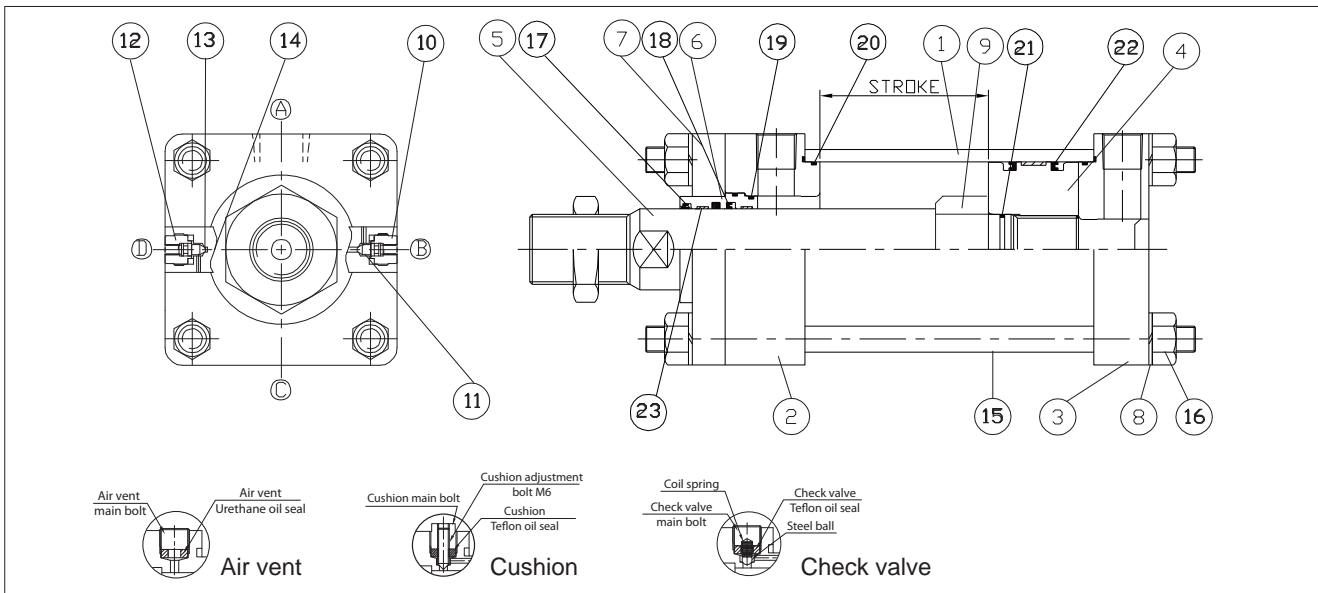

Hydraulic Cylinder
Reference Data
KP140H
KP210H
KPC70/140H
KPC210H
KTC70HP
KP140HS
KP125/160A
KP35R
KH

Part List

Part no.	Parts	Material	Quantity
1	Cylinder Tube	STKM13C	1
2	Rod Cover	SS400	1
3	Head Cover	SS400	1
4	Piston	SM45C	1
5	Piston Rod	SM45C	1
6	Bush	SM45C	1
7	Retainer (Bush Cover)	SS400	1
8	Spring Washer	SS400	8

Part no.	Parts	Material	Quantity
9	Cushion Ring	SM45C	1
10	Cushion Body	SUM24L	2
11	Cushion Needle	SUM24L	2
12	Check Body	SUM24L	2
13	Coil Spring	SUP	2
14	Steel Ball	SUJ2	2
15	Tie Rod	SM45C	4
16	Hex Nut (2 Kinds)	SM45C	8

Packing List

Part no.	Parts	Ø140 (C)	Ø150 (C)	Ø160 (C)	Ø180 (C)	Ø200 (C)	Ø250 (C)	Material	Qty.
17	Dust Seal	65x73x5/6.5	65x73x5/6.5	70x80x6/8	80x90x6/8	LBI-90	110x120x6/8	Urethane	1
18									
19	Rod Packing	65x75x6	65x75x6	70x80x6	80x90x6	USH-90	110x125x9	Urethane	1
20									
21	Bushing O-Ring	G80	G95	G100	G110	G125	G155	NBR	1
22									
23	Tube O-Ring	G120	G145	G150	G170	G190	G240	NBR	2
24	Rod O-Ring	G60	G60	G65	G75	G85	G105	NBR	1
25									
26	Piston Packing	140x115x25.4/9.5	150x125x25.4/9.5	160x135x25.4/9.5	180x155x25.4	200x175x25.4	250x225x25.4	NBR	1
27	Wear Ring	65x70x10	65x70x10	2.5x25/10	80x85x10	2.5x15	282x15x2.5	Phenol	2

Part no.	Parts	Ø140 (B)	Ø150 (B)	Ø160 (B)	Ø180 (B)	Ø200 (B)	Ø250 (B)	Material	Qty.
17	Dust Seal	80x90x6/8	85x95x6/8	90x100x6/8	100x110x6/8	LBH-110	140x153x7/9.6	Urethane	1
18									
19	Rod Packing	80x90x6	85x100x9	90x105x9.5	100x115x9	USH-110	140x155x9.5	Urethane	1
20									
21	Bushing O-Ring	G80	G95	G100	G110	G125	G155	NBR	1
22									
23	Tube O-Ring	G120	G145	G150	G170	G190	G240	NBR	2
24	Rod O-Ring	G60	G60	G65	G75	G85	G105	NBR	1
25									
26	Piston Packing	140x115x25.4/9.5	150x125x25.4/9.5	160x135x25.4/9.5	180x155x25.4	200x175x25.4	250x225x25.4	NBR	1
27	Wear Ring	80x85x10	85x90x15	2.5x25/10	100x105x10	2.5x15	282x15x2.5	Phenol	2

Dimensions-Standard (SD)

70kgf/cm² • 140kgf/cm²

※ Shape varies depending on bore sizes.

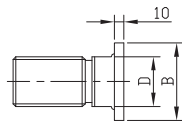

D:Width cross flat (for spanner)

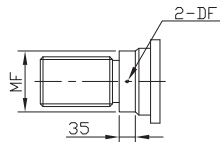

※ To the bore size of Ø100 a hole is placed with the width cross flat.

Bore size	MF	DF
Ø100	Ø97	Ø12
Ø110	Ø109	Ø15
Ø140	Ø137	Ø15

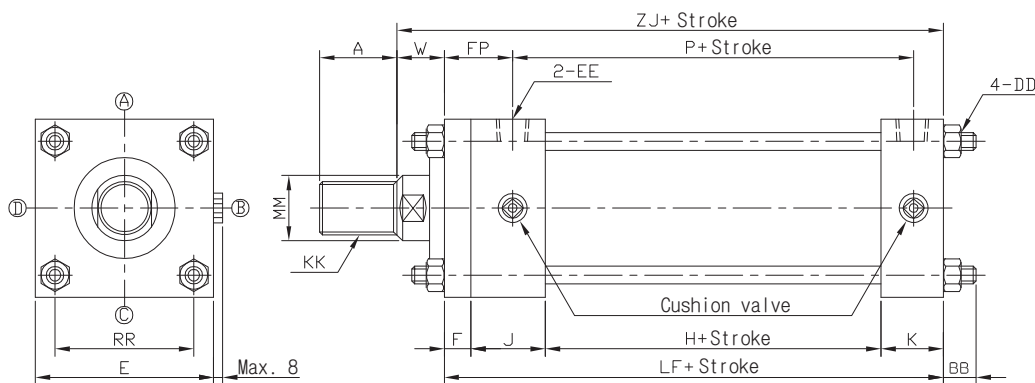

Double rod type (Ø40 ~ Ø160)

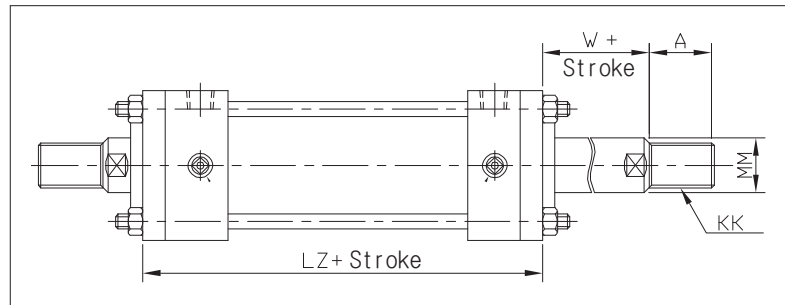

Cylinder cover fixing method according to stroke
Unit:mm

Bore size	~1500	1501~2000
Ø80~Ø250	Tie rod type	Tube flange type

Unit : mm

Bore size	Bore size (B type)					Bore size (C type)					BB	DD	E	EE	F	FP	H	J	K	LF	LZ	P	RR	W	ZJ
	A	B	D	KK	MM	A	B	D	KK	MM															
Ø40	30	Ø40	21	M20X1.5	Ø22	25	Ø36	17	M16X1.5	Ø18	15	M10x1.25	□65	Rc(PT)3/8	11	38	54	45	31	141	166	90	45	30	171
Ø50	35	Ø45	24	M24X1.5	Ø28	30	Ø40	20	M20X1.5	Ø22	15	M10x1.25	□76	Rc(PT)1/2	13	42	58	49	35	155	182	98	52	30	185
Ø63	45	Ø55	30	M30X1.5	Ø35	35	Ø45	24	M24X1.5	Ø28	17	M12x1.5	□90	Rc(PT)1/2	15	46	62	51	35	163	194	102	63	35	198
Ø80	60	Ø65	41	M39X1.5	Ø45	45	Ø55	30	M30X1.5	Ø35	23	M16x1.5	□110	Rc(PT)3/4	18	56	64	59	39	180	218	106	80	35	215
Ø100	75	Ø80	50	M48X1.5	Ø55	60	Ø65	41	M39X1.5	Ø45	26	M18x1.5	□135	Rc(PT)3/4	20	58	70	61	41	192	232	116	102	40	232
Ø125	95	Ø95	65	M64X2	Ø70	75	Ø80	50	M48X1.5	Ø55	30	M22x1.5	□165	Rc(PT)1	24	67	82	67	47	220	264	130	122	45	265
Ø140	110	Ø105	75	M72X2	Ø80	80	Ø85	60	M56X2	Ø65	35	M24x1.5	□185	Rc(PT)1	26	67	96	64	44	230	276	142.5	138	50	280
Ø150	115	Ø110	80	M76X2	Ø85	85	Ø90	60	M60X2	Ø65	35	M27x1.5	□196	Rc(PT)1	28	68	104	64	44	240	288	151.5	148	50	290
Ø160	120	Ø115	85	M80X2	Ø90	95	Ø95	65	M64X2	Ø70	35	M27x1.5	□210	Rc(PT)1	31	74	106	68	48	253	304	156	160	55	308
Ø180	140	Ø125	-	M95X2	Ø100	110	Ø105	75	M72X2	Ø80	40	M30x1.5	□235	Rc(PT)1 1/4	33	75	116	70	56	275	-	172	182	55	330
Ø200	150	Ø140	-	M100X2	Ø110	120	Ø135	85	M80X2	Ø90	40	M33x1.5	□262	Rc(PT)1 1/2	37	85	118	83	63	301	-	185	200	55	356
Ø250	195	Ø170	-	M130X2	Ø140	150	Ø140	-	M100X2	Ø112	50	M42x1.5	□325	Rc(PT)2	46	106	126	118	98	346	-	200	250	65	411

Dimensions-Axial Angle of Foot (LA)

70kgf/cm² • 140kgf/cm²

※ Shape varies depending on bore sizes.

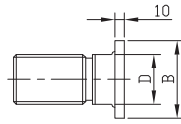

D:Width cross flat (for spanner)

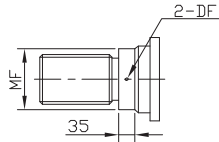

※ To the bore size of Ø100 a hole is placed with the width cross flat.

Bore size	MF	DF
Ø100	Ø97	Ø12
Ø110	Ø109	Ø15
Ø140	Ø137	Ø15

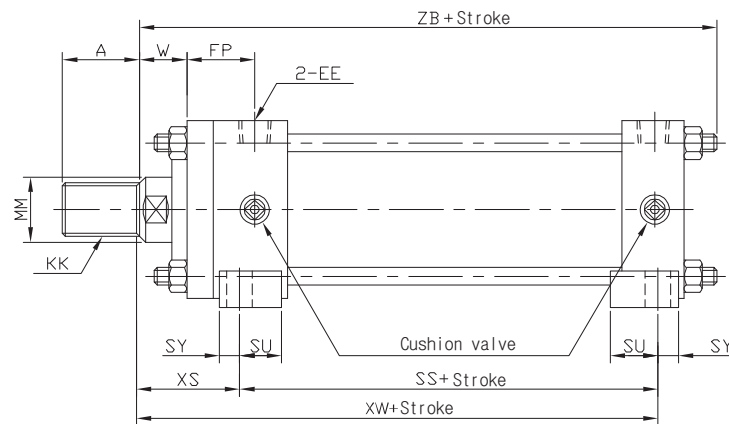
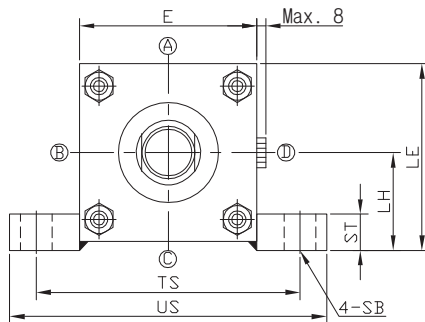

Double rod type (Ø40 ~ Ø160)

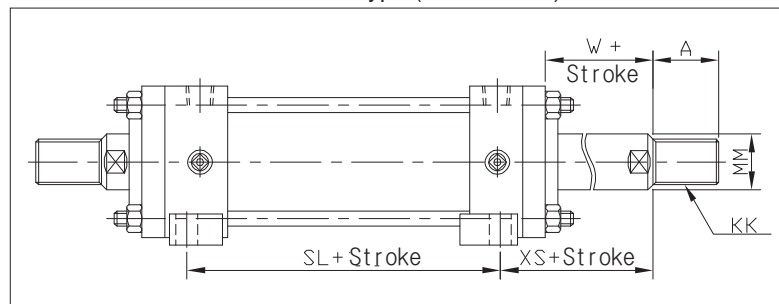

※ For not shown dimensions, refer to SD type (standard type).

Cylinder cover fixing method according to stroke
Unit:mm

Bore size	~1500	1501~2000
Ø80~Ø250	Tie rod type	Tube flange type

Hydraulic Cylinder

Reference Data

KP140H

KP210H

KPC70/140H

KPC210H

KTC70HP

KP140HS

KP125/160A

KP35R

KH

Unit : mm

Bore size	Bore size (B type)					Bore size (C type)					E	EE	FP	LE	LH	SB	SL	SS	ST	SU	SY	TS	US	W	XS	XW	ZB
	A	B	D	KK	MM	A	B	D	KK	MM																	
Ø40	30	Ø40	21	M20X1.5	Ø22	25	Ø36	17	M16X1.5	Ø18	□65	Rc(PT)3/8	38	70	37.5±0.15	Ø11	112	98	14	31	13	95	118	30	57	155	186
Ø50	35	Ø45	24	M24X1.5	Ø28	30	Ø40	20	M20X1.5	Ø22	□76	Rc(PT)1/2	42	83	45±0.15	Ø14	122	108	17	34	14	115	145	30	60	168	200
Ø63	45	Ø55	30	M30X1.5	Ø35	35	Ø45	24	M24X1.5	Ø28	□90	Rc(PT)1/2	46	95	50±0.15	Ø18	122	106	19	32	18	132	165	35	71	177	215
Ø80	60	Ø65	41	M39X1.5	Ø45	45	Ø55	30	M30X1.5	Ø35	□110	Rc(PT)3/4	56	115	60±0.15	Ø18	140	120	25	42	18	155	190	35	74	194	238
Ø100	75	Ø80	50	M48X1.5	Ø55	60	Ø65	41	M39X1.5	Ø45	□135	Rc(PT)3/4	58	138.5	71±0.15	Ø22	142	122	27	38	22	190	230	40	85	207	258
Ø125	95	Ø95	65	M64X2	Ø70	75	Ø80	50	M48X1.5	Ø55	□165	Rc(PT)1	67	167.5	85±0.15	Ø26	156	136	32	41	25	224	272	45	99	235	295
Ø140	110	Ø105	75	M72X2	Ø80	80	Ø85	60	M56X2	Ø65	□185	Rc(PT)1	67	187.5	95±0.15	Ø26	164	144	35	41	25	250	300	50	106	250	315
Ø150	115	Ø110	80	M76X2	Ø85	85	Ø90	60	M60X2	Ø65	□196	Rc(PT)1	68	204	106±0.15	Ø30	166	146	37	38	28	270	320	50	111	257	325
Ø160	120	Ø115	85	M80X2	Ø90	95	Ø95	65	M64X2	Ø70	□210	Rc(PT)1	74	217	112±0.15	Ø33	170	150	42	40	31	285	345	55	122	272	343
Ø180	140	Ø125	-	M95X2	Ø100	110	Ø105	75	M72X2	Ø80	□235	Rc(PT)1 1/4	75	242.5	125±0.25	Ø33	-	172	47	-	35	315	375	55	123	295	370
Ø200	150	Ø140	-	M100X2	Ø112	120	Ø115	85	M80X2	Ø90	□262	Rc(PT)1 1/2	85	271	140±0.25	Ø36	-	186	52	-	39	355	425	55	131	317	396
Ø250	195	Ø170	-	M130X2	Ø140	150	Ø140	-	M100X2	Ø112	□325	Rc(PT)2	106	332.5	170±0.25	Ø45	-	206	57	-	47	425	515	65	158	364	461

Dimensions-Axial Foot (LB)

70kgf/cm²

※ Shape varies depending on bore sizes.

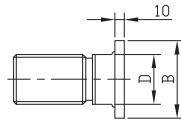

D:Width cross flat
(for spanner)

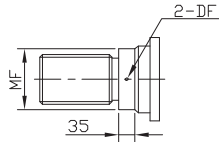

※ To the bore size of Ø100 a hole is placed with the width cross flat.

Bore size	MF	DF
Ø100	Ø97	Ø12
Ø110	Ø109	Ø15
Ø140	Ø137	Ø15

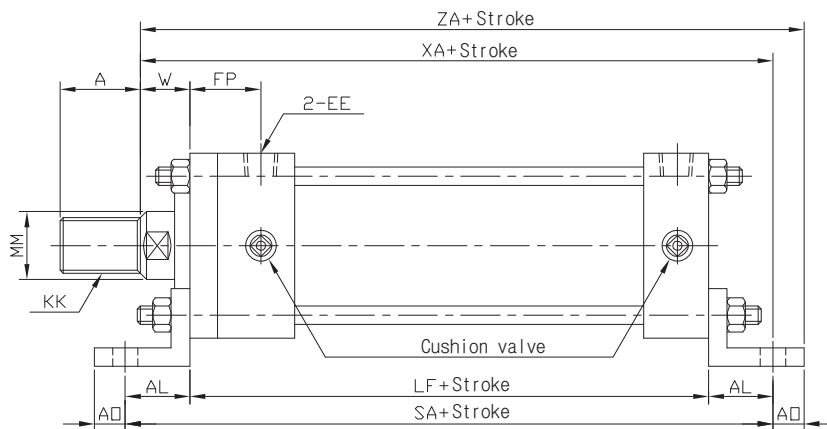
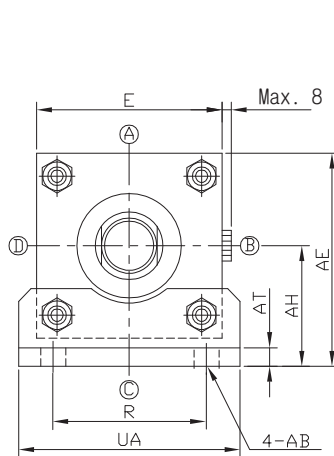

Double rod type (Ø40 ~ Ø160)

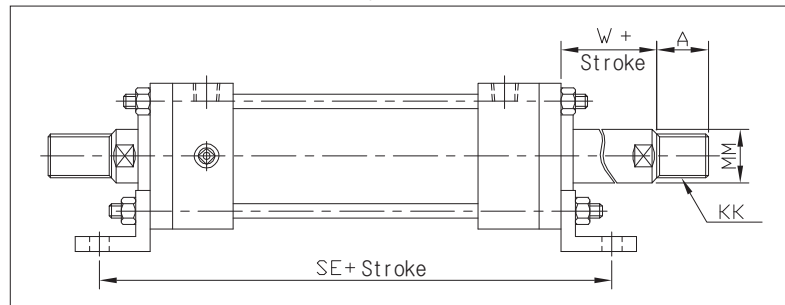

※ For not shown dimensions, refer to SD type (standard type).

Cylinder cover fixing method according to stroke
Unit:mm

Bore size	~1500	1501~2000
Ø80~Ø250	Tie rod type	Tube flange type

Unit : mm

Bore size	Bore size (B type)					Bore size (C type)					AB	AE	AH	AL	AO	AT	E	EE	FP	LF	R	SA	SE	UA	W	XA	ZA
	A	B	D	KK	MM	A	B	D	KK	MM																	
Ø40	30	Ø40	21	M20X1.5	Ø22	25	Ø36	17	M16X1.5	Ø18	Ø11	75.5	43±0.15	32	13	9	□65	Rc(PT)3/8	38	141	46	205	230	69	30	203	216
Ø50	35	Ø45	24	M24X1.5	Ø28	30	Ø40	20	M20X1.5	Ø22	Ø14	87.5	50±0.15	35	15	9	□76	Rc(PT)1/2	42	155	58	225	252	85	30	220	235
Ø63	45	Ø55	30	M30X1.5	Ø35	35	Ø45	24	M24X1.5	Ø28	Ø18	105	60±0.15	42	18	12	□90	Rc(PT)1/2	46	163	65	247	278	98	35	240	258
Ø80	60	Ø65	41	M39X1.5	Ø45	45	Ø55	30	M30X1.5	Ø35	Ø18	127	72±0.25	50	20	13	□110	Rc(PT)3/4	56	180	87	280	318	118	35	265	285
Ø100	75	Ø80	50	M48X1.5	Ø55	60	Ø65	41	M39X1.5	Ø45	Ø22	152.5	82±0.25	55	23	13	□135	Rc(PT)3/4	58	192	109	302	342	150	40	287	310
Ø125	95	Ø95	65	M64X2	Ø70	75	Ø80	50	M48X1.5	Ø55	Ø26	187.5	105±0.25	66	29	15	□165	Rc(PT)1	67	220	130	352	396	175	45	331	360
Ø140	110	Ø105	75	M72X2	Ø80	80	Ø85	60	M56X2	Ø65	Ø26	207.5	115±0.25	70	30	18	□185	Rc(PT)1	67	230	145	370	416	195	50	350	380
Ø150	115	Ø110	80	M76X2	Ø85	85	Ø90	60	M60X2	Ø65	Ø30	221	123±0.25	75	30	18	□196	Rc(PT)1	68	240	155	390	438	210	50	365	395
Ø160	120	Ø115	85	M80X2	Ø90	95	Ø95	65	M64X2	Ø70	Ø33	237	132±0.25	75	35	18	□210	Rc(PT)1	74	253	170	403	454	225	55	383	418
Ø180	140	Ø125	-	M95X2	Ø100	110	Ø105	75	M72X2	Ø80	Ø33	265.5	148±0.25	85	40	20	□235	Rc(PT)1 1/4	75	275	185	445	-	243	55	415	455
Ø200	150	Ø140	-	M100X2	Ø112	120	Ø115	85	M80X2	Ø90	Ø36	296	165±0.25	98	40	25	□262	Rc(PT)1 1/2	85	301	206	497	-	272	55	454	494
Ø250	195	Ø170	-	M130X2	Ø140	150	Ø140	-	M100X2	Ø112	Ø45	370.5	208±0.25	130	50	35	□325	Rc(PT)2	106	346	250	606	-	335	65	541	591

Dimensions-Rod Side Rectangular Flange (FA)

70kgf/cm²

※ Shape varies depending on bore sizes.

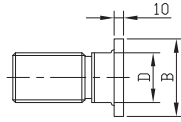

D:Width cross flat
(for spanner)

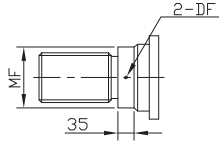

※ To the bore size of Ø100 a hole is placed with the width cross flat.

Bore size	MF	DF
Ø100	Ø97	Ø12
Ø110	Ø109	Ø15
Ø140	Ø137	Ø15

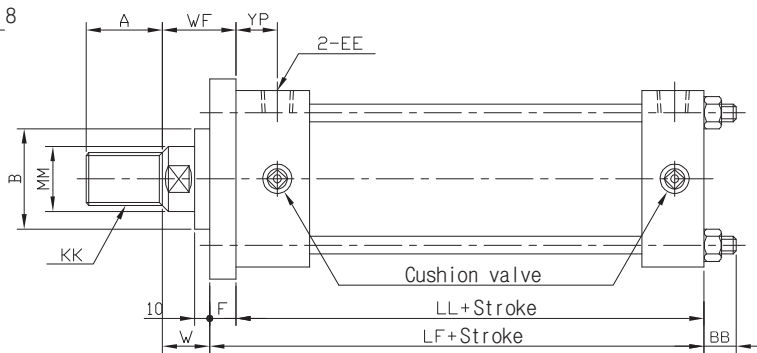
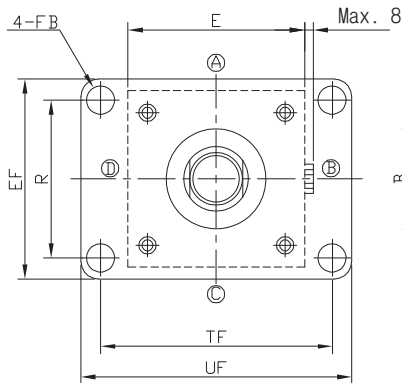

Double rod type (Ø40 ~ Ø160)

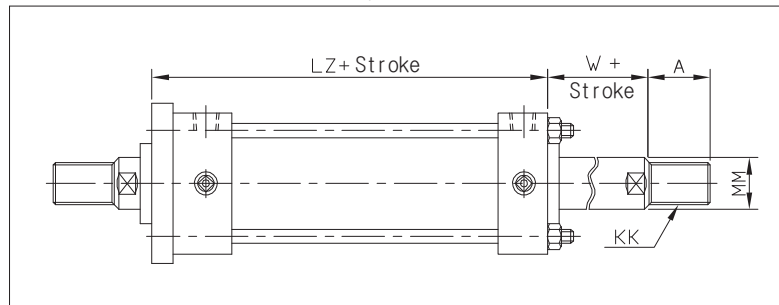

※ For not shown dimensions, refer to SD type (standard type).

Cylinder cover fixing method according to stroke
Unit:mm

Bore size	~1500	1501~2000
Ø80~Ø250	Tie rod type	Tube flange type

Hydraulic Cylinder

Reference Data

KP140H

KP210H

KPC70/140H

KPC210H

KTC70HP

KP140HS

KP125/160A

KP35R

KH

Unit : mm

Bore size	Bore size (B type)					Bore size (C type)					BB	E	EE	EF	F	FB	LF	LL	LZ	R	TF	UF	W	WF	YP
	A	B	D	KK	MM	A	B	D	KK	MM															
Ø40	30	Ø40	21	M20X1.5	Ø22	25	Ø36	17	M16X1.5	Ø18	15	□65	Rc(PT)3/8	69	11	Ø11	141	130	166	46	95	118	30	41	27
Ø50	35	Ø45	24	M24X1.5	Ø28	30	Ø40	20	M20X1.5	Ø22	15	□76	Rc(PT)1/2	85	13	Ø14	155	142	182	58	115	145	30	43	29
Ø63	45	Ø55	30	M30X1.5	Ø35	35	Ø45	24	M24X1.5	Ø28	17	□90	Rc(PT)1/2	98	15	Ø18	163	148	194	65	132	165	35	50	31
Ø80	60	Ø65	41	M39X1.5	Ø45	45	Ø55	30	M30X1.5	Ø35	23	□110	Rc(PT)3/4	118	18	Ø18	180	162	218	87	155	190	35	53	38
Ø100	75	Ø80	50	M48X1.5	Ø55	60	Ø65	41	M39X1.5	Ø45	26	□135	Rc(PT)3/4	150	20	Ø22	192	172	232	109	190	230	40	60	38
Ø125	95	Ø95	65	M64X2	Ø70	75	Ø80	50	M48X1.5	Ø55	30	□165	Rc(PT)1	175	24	Ø26	220	196	264	130	224	272	45	69	43
Ø140	110	Ø105	75	M72X2	Ø80	80	Ø85	60	M56X2	Ø65	35	□185	Rc(PT)1	195	26	Ø26	230	204	276	145	250	300	50	76	41
Ø150	115	Ø110	80	M76X2	Ø85	85	Ø90	60	M60X2	Ø65	35	□196	Rc(PT)1	210	28	Ø30	240	212	288	155	270	320	50	78	40
Ø160	120	Ø115	85	M80X2	Ø90	95	Ø95	65	M64X2	Ø70	35	□210	Rc(PT)1	225	31	Ø33	253	222	304	170	285	345	55	86	43
Ø180	140	Ø125	-	M95X2	Ø100	110	Ø105	75	M72X2	Ø80	40	□235	Rc(PT)1 1/4	243	33	Ø33	275	242	-	185	315	375	55	88	42
Ø200	150	Ø140	-	M100X2	Ø112	120	Ø115	85	M80X2	Ø90	40	□262	Rc(PT)1 1/2	272	37	Ø36	301	264	-	206	355	425	55	92	48
Ø250	195	Ø170	-	M130X2	Ø140	150	Ø140	-	M100X2	Ø112	50	□325	Rc(PT)2	335	46	Ø45	346	300	-	250	425	515	65	111	60

Dimensions-Head Side Rectangular Flange (FB)

70kgf/cm²

※ Shape varies depending on bore sizes.

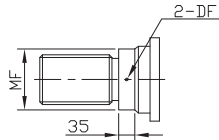
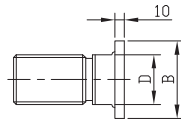

Bore size	MF	DF
Ø100	Ø97	Ø12
Ø110	Ø109	Ø15
Ø140	Ø137	Ø15

D:Width cross flat
(for spanner)

※ To the bore size of Ø100 a hole is placed with the width cross flat.

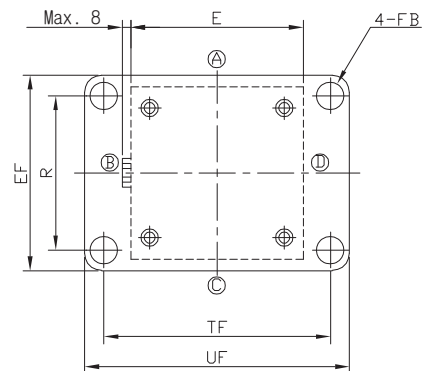
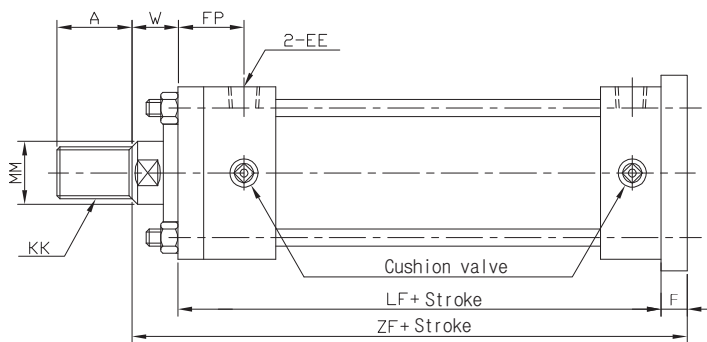

Double rod type (Ø40 ~ Ø160)

※ For not shown dimensions, refer to SD type (standard type).

Cylinder cover fixing method according to stroke
Unit:mm

Bore size	~1500	1501~2000
Ø80~Ø250	Tie rod type	Tube flange type

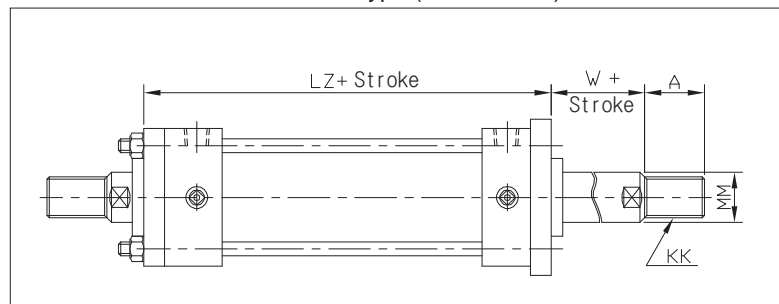

Unit : mm

Bore size	Bore size (B type)					Bore size (C type)					E	EE	EF	F	FB	FP	LF	LZ	R	TF	UF	W	ZF
	A	B	D	KK	MM	A	B	D	KK	MM													
Ø40	30	Ø40	21	M20X1.5	Ø22	25	Ø36	17	M16X1.5	Ø18	□65	Rc(PT)3/8	69	11	Ø11	38	141	166	46	95	118	30	182
Ø50	35	Ø45	24	M24X1.5	Ø28	30	Ø40	20	M20X1.5	Ø22	□76	Rc(PT)1/2	85	13	Ø14	42	155	182	58	115	145	30	198
Ø63	45	Ø55	30	M30X1.5	Ø35	35	Ø45	24	M24X1.5	Ø28	□90	Rc(PT)1/2	98	15	Ø18	46	163	194	65	132	165	35	213
Ø80	60	Ø65	41	M39X1.5	Ø45	45	Ø55	30	M30X1.5	Ø35	□110	Rc(PT)3/4	118	18	Ø18	56	180	218	87	155	190	35	233
Ø100	75	Ø80	50	M48X1.5	Ø55	60	Ø65	41	M39X1.5	Ø45	□135	Rc(PT)3/4	150	20	Ø22	58	192	232	109	190	230	40	252
Ø125	95	Ø95	65	M64X2	Ø70	75	Ø80	50	M48X1.5	Ø55	□165	Rc(PT)1	175	24	Ø26	67	220	264	130	224	272	45	289
Ø140	110	Ø105	75	M72X2	Ø80	80	Ø85	60	M56X2	Ø65	□185	Rc(PT)1	195	26	Ø26	67	230	276	145	250	300	50	306
Ø150	115	Ø110	80	M76X2	Ø85	85	Ø90	60	M60X2	Ø65	□196	Rc(PT)1	210	28	Ø30	68	240	288	155	270	320	50	318
Ø160	120	Ø115	85	M80X2	Ø90	95	Ø95	65	M64X2	Ø70	□210	Rc(PT)1	225	31	Ø33	74	253	304	170	285	345	55	339
Ø180	140	Ø125	-	M95X2	Ø100	110	Ø105	75	M72X2	Ø80	□235	Rc(PT)1 1/4	243	33	Ø33	75	275	-	185	315	375	55	363
Ø200	150	Ø140	-	M100X2	Ø112	120	Ø115	85	M80X2	Ø90	□262	Rc(PT)1 1/2	272	37	Ø36	85	301	-	206	355	425	55	393
Ø250	195	Ø170	-	M130X2	Ø140	150	Ø140	-	M100X2	Ø112	□325	Rc(PT)2	335	46	Ø45	106	346	-	250	425	515	65	457

Dimensions-Reinforced Type Rod Side Rectangular Flange (FY)

70kgf/cm² · 140kgf/cm²

※ Shape varies depending on bore sizes.

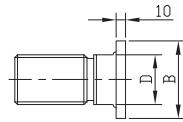

D:Width cross flat
(for spanner)

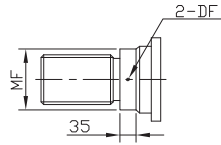

※ To the bore size of Ø100 a hole is placed with the width cross flat.

Bore size	MF	DF
Ø100	Ø97	Ø12
Ø110	Ø109	Ø15
Ø140	Ø137	Ø15

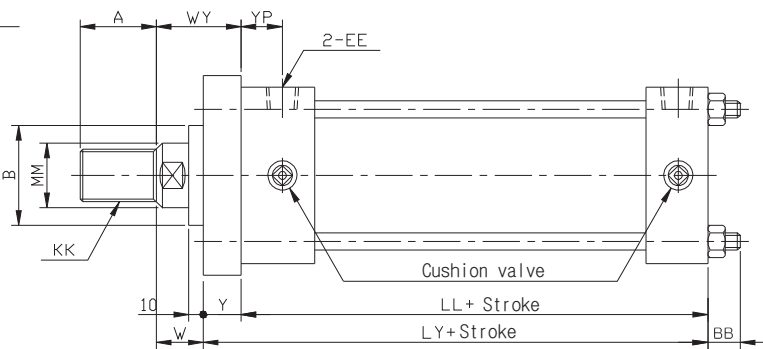
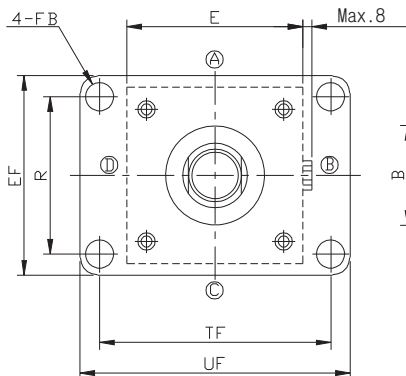

Double rod type (Ø40 ~ Ø160)

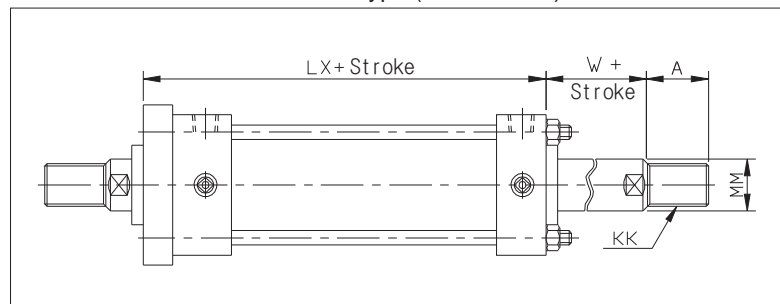

- ※ For not shown dimensions, refer to SD type (standard type).
- ※ FY type has high mounting rigidity with its reinforced flange thickness compare with FA flange.

Cylinder cover fixing method according to stroke
Unit:mm

Bore size	~1500	1501~2000
Ø80~Ø250	Tie rod type	Tube flange type

Unit : mm

Bore size	Bore size (B type)					Bore size (C type)					BB	E	EE	EF	FB	LL	LX	LY	R	TF	UF	W	WY	Y	YP
	A	B	D	KK	MM	A	B	D	KK	MM															
Ø40	30	Ø40	21	M20X1.5	Ø22	25	Ø36	17	M16X1.5	Ø18	15	□65	Rc(PT)3/8	69	Ø11	130	168	143	46	95	118	30	43	13	27
Ø50	35	Ø45	24	M24X1.5	Ø28	30	Ø40	20	M20X1.5	Ø22	15	□76	Rc(PT)1/2	85	Ø14	142	187	160	58	115	145	30	48	18	29
Ø63	45	Ø55	30	M30X1.5	Ø35	35	Ø45	24	M24X1.5	Ø28	17	□90	Rc(PT)1/2	98	Ø18	148	199	168	65	132	165	35	55	20	31
Ø80	60	Ø65	41	M39X1.5	Ø45	45	Ø55	30	M30X1.5	Ø35	23	□110	Rc(PT)3/4	118	Ø18	162	224	186	87	155	190	35	59	24	38
Ø100	75	Ø80	50	M48X1.5	Ø55	60	Ø65	41	M39X1.5	Ø45	26	□135	Rc(PT)3/4	150	Ø22	172	240	200	109	190	230	40	68	28	38
Ø125	95	Ø95	65	M64X2	Ø70	75	Ø80	50	M48X1.5	Ø55	30	□165	Rc(PT)1	175	Ø26	196	273	229	130	224	272	45	78	33	43
Ø140	110	Ø105	75	M72X2	Ø80	80	Ø85	60	M56X2	Ø65	35	□185	Rc(PT)1	195	Ø26	204	287	241	145	250	300	50	87	37	41
Ø150	115	Ø110	80	M76X2	Ø85	85	Ø90	60	M60X2	Ø65	35	□196	Rc(PT)1	210	Ø30	212	299	251	155	270	320	50	89	39	40
Ø160	120	Ø115	85	M80X2	Ø90	95	Ø95	65	M64X2	Ø70	35	□210	Rc(PT)1	225	Ø33	222	314	263	170	285	345	55	96	41	43
Ø180	140	Ø125	-	M95X2	Ø100	110	Ø105	75	M72X2	Ø80	40	□235	Rc(PT)1 1/4	243	Ø33	242	-	288	185	315	375	55	101	46	42
Ø200	150	Ø140	-	M100X2	Ø112	120	Ø115	85	M80X2	Ø90	40	□262	Rc(PT)1 1/2	272	Ø36	264	-	315	206	355	425	55	106	51	48
Ø250	195	Ø170	-	M130X2	Ø140	150	Ø140	-	M100X2	Ø112	50	□325	Rc(PT)2	335	Ø45	300	-	365	250	425	515	65	130	65	60

Dimensions-Reinforced Type Head Side Rectangular Flange (FZ)

70kgf/cm² · 140kgf/cm²

※ Shape varies depending on bore sizes.

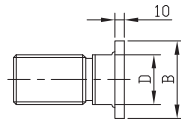

D:Width cross flat
(for spanner)

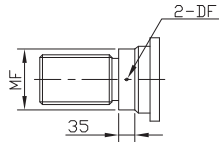

※ To the bore size of Ø100 a hole is placed with the width cross flat.

Bore size	MF	DF
Ø100	Ø97	Ø12
Ø110	Ø109	Ø15
Ø140	Ø137	Ø15

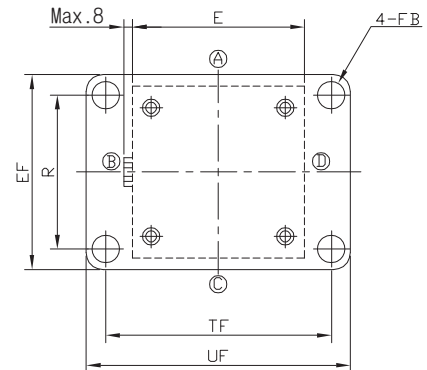
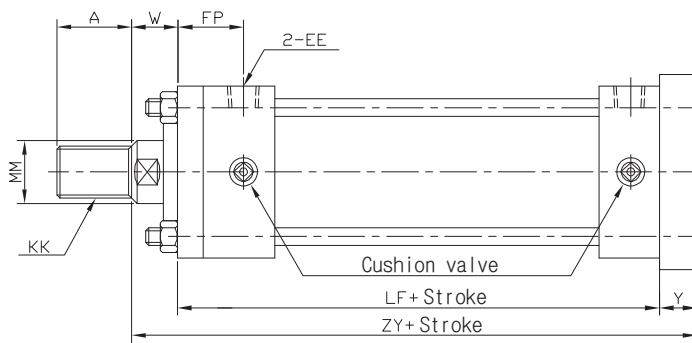

Double rod type (Ø40 ~ Ø160)

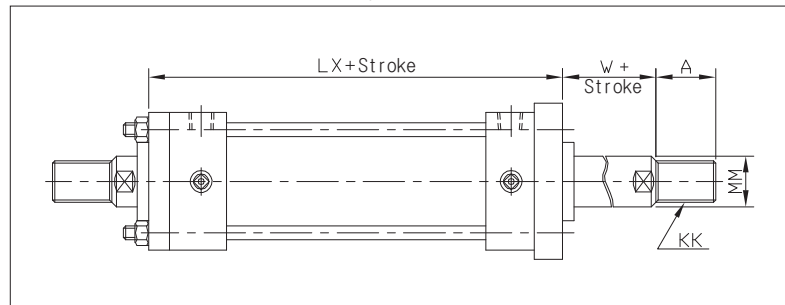

- ※ For not shown dimensions, refer to SD type (standard type).
- ※ FZ type has high mounting rigidity with its reinforced flange thickness compare with FB flange.

Cylinder cover fixing method according to stroke
Unit:mm

Bore size	~1500	1501~2000
Ø80~Ø250	Tie rod type	Tube flange type

Unit : mm

Bore size	Bore size (B type)					Bore size (C type)					E	EE	EF	FB	FP	LF	LX	R	TF	UF	W	Y	ZY
	A	B	D	KK	MM	A	B	D	KK	MM													
Ø40	30	Ø40	21	M20X1.5	Ø22	25	Ø36	17	M16X1.5	Ø18	□65	Rc(PT)3/8	69	Ø11	38	141	168	46	95	118	30	13	184
Ø50	35	Ø45	24	M24X1.5	Ø28	30	Ø40	20	M20X1.5	Ø22	□76	Rc(PT)1/2	85	Ø14	42	155	187	58	115	145	30	18	203
Ø63	45	Ø55	30	M30X1.5	Ø35	35	Ø45	24	M24X1.5	Ø28	□90	Rc(PT)1/2	98	Ø18	46	163	199	65	132	165	35	20	218
Ø80	60	Ø65	41	M39X1.5	Ø45	45	Ø55	30	M30X1.5	Ø35	□110	Rc(PT)3/4	118	Ø18	56	180	224	87	155	190	35	24	239
Ø100	75	Ø80	50	M48X1.5	Ø55	60	Ø65	41	M39X1.5	Ø45	□135	Rc(PT)3/4	150	Ø22	58	192	240	109	190	230	40	28	260
Ø125	95	Ø95	65	M64X2	Ø70	75	Ø80	50	M48X1.5	Ø55	□165	Rc(PT)1	175	Ø26	67	220	273	130	224	272	45	33	298
Ø140	110	Ø105	75	M72X2	Ø80	80	Ø85	60	M56X2	Ø65	□185	Rc(PT)1	195	Ø26	67	230	287	145	250	300	50	37	317
Ø150	115	Ø110	80	M76X2	Ø85	85	Ø90	60	M60X2	Ø65	□196	Rc(PT)1	210	Ø30	68	240	299	155	270	320	50	39	329
Ø160	120	Ø115	85	M80X2	Ø90	95	Ø95	65	M64X2	Ø70	□210	Rc(PT)1	225	Ø33	74	253	314	170	285	345	55	41	349
Ø180	140	Ø125	-	M95X2	Ø100	110	Ø105	75	M72X2	Ø80	□235	Rc(PT)1 1/4	243	Ø33	75	275	-	185	315	375	55	46	376
Ø200	150	Ø140	-	M100X2	Ø112	120	Ø115	85	M80X2	Ø90	□262	Rc(PT)1 1/2	272	Ø36	85	301	-	206	355	425	55	51	407
Ø250	195	Ø170	-	M130X2	Ø140	150	Ø140	-	M100X2	Ø112	□325	Rc(PT)2	335	Ø45	106	346	-	250	425	515	65	65	476

Dimensions-Rod Side Square Flange (FC)

70kgf/cm² • 140kgf/cm² ※ Shape varies depending on bore sizes.

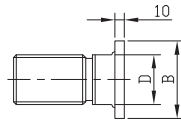

D:Width cross flat (for spanner)

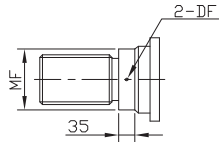

※ To the bore size of Ø100 a hole is placed with the width cross flat.

Bore size	MF	DF
Ø100	Ø97	Ø12
Ø110	Ø109	Ø15
Ø140	Ø137	Ø15

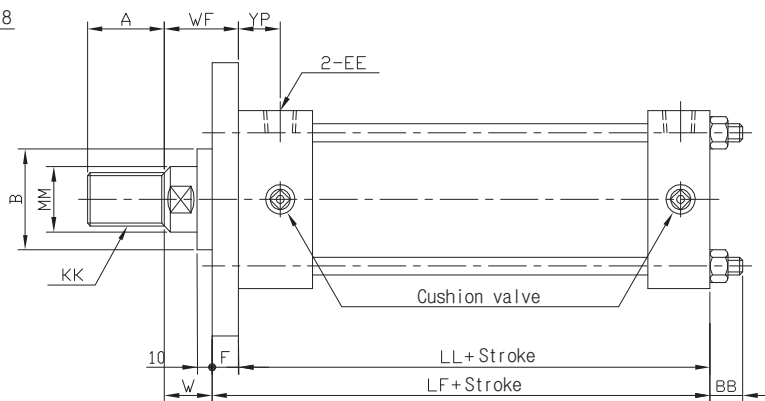
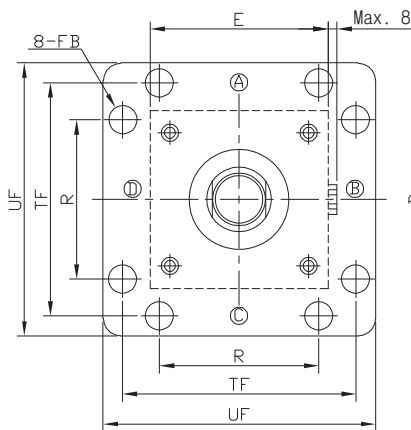

Double rod type (Ø40 ~ Ø160)

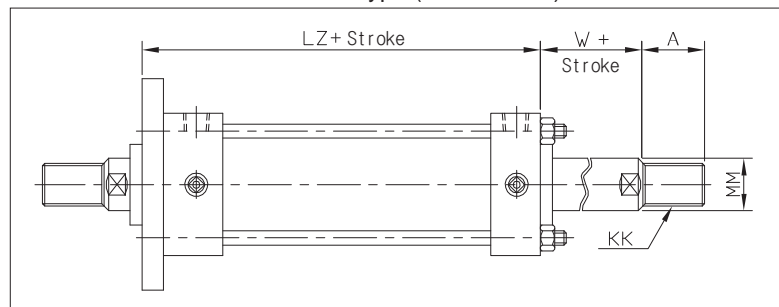

※ For not shown dimensions, refer to SD type (standard type).

Cylinder cover fixing method according to stroke
Unit:mm

Bore size	~1500	1501~2000
Ø80~Ø250	Tie rod type	Tube flange type

Hydraulic Cylinder

Reference Data

KP140H
KP210H
KPC70/140H
KPC210H
KTC70HP
KP140HS
KP125/160A
KP35R
KH

Unit : mm

Bore size	Bore size (B type)					Bore size (C type)					BB	E	EE	F	FB	LF	LL	LZ	R	TF	UF	W	WF	YP
	A	B	D	KK	MM	A	B	D	KK	MM														
Ø40	30	Ø40	21	M20X1.5	Ø22	25	Ø36	17	M16X1.5	Ø18	15	□65	Rc(PT)3/8	11	Ø11	141	130	166	46	95	118	30	41	27
Ø50	35	Ø45	24	M24X1.5	Ø28	30	Ø40	20	M20X1.5	Ø22	15	□76	Rc(PT)1/2	13	Ø14	155	142	182	58	115	145	30	43	29
Ø63	45	Ø55	30	M30X1.5	Ø35	35	Ø45	24	M24X1.5	Ø28	17	□90	Rc(PT)1/2	15	Ø18	163	148	194	65	132	165	35	50	31
Ø80	60	Ø65	41	M39X1.5	Ø45	45	Ø55	30	M30X1.5	Ø35	23	□110	Rc(PT)3/4	18	Ø18	180	162	218	87	155	190	35	53	38
Ø100	75	Ø80	50	M48X1.5	Ø55	60	Ø65	41	M39X1.5	Ø45	26	□135	Rc(PT)3/4	20	Ø22	192	172	232	109	190	230	40	60	38
Ø125	95	Ø95	65	M64X2	Ø70	75	Ø80	50	M48X1.5	Ø55	30	□165	Rc(PT)1	24	Ø26	220	196	264	130	224	272	45	69	43
Ø140	110	Ø105	75	M72X2	Ø80	80	Ø85	60	M56X2	Ø65	35	□185	Rc(PT)1	26	Ø26	230	204	276	145	250	300	50	76	41
Ø150	115	Ø110	80	M76X2	Ø85	85	Ø90	60	M60X2	Ø65	35	□196	Rc(PT)1	28	Ø30	240	212	288	155	270	320	50	78	40
Ø160	120	Ø115	85	M80X2	Ø90	95	Ø95	65	M64X2	Ø70	35	□210	Rc(PT)1	31	Ø33	253	222	304	170	285	345	55	86	43
Ø180	140	Ø125	-	M95X2	Ø100	110	Ø105	75	M72X2	Ø80	40	□235	Rc(PT)1 1/4	33	Ø33	275	242	-	185	315	375	55	88	42
Ø200	150	Ø140	-	M100X2	Ø112	120	Ø115	85	M80X2	Ø90	40	□262	Rc(PT)1 1/2	37	Ø36	301	264	-	206	355	425	55	92	48
Ø250	195	Ø170	-	M130X2	Ø140	150	Ø140	-	M100X2	Ø112	50	□325	Rc(PT)2	46	Ø45	346	300	-	250	425	515	65	111	60

Dimensions-Head Side Square Flange (FD)

70kgf/cm² • 140kgf/cm²

※ Shape varies depending on bore sizes.

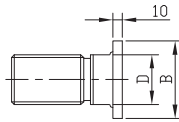

D:Width cross flat
(for spanner)

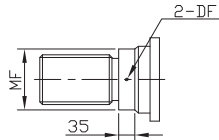

※ To the bore size of Ø100 a hole is placed with the width cross flat.

Bore size	MF	DF
Ø100	Ø97	Ø12
Ø110	Ø109	Ø15
Ø140	Ø137	Ø15

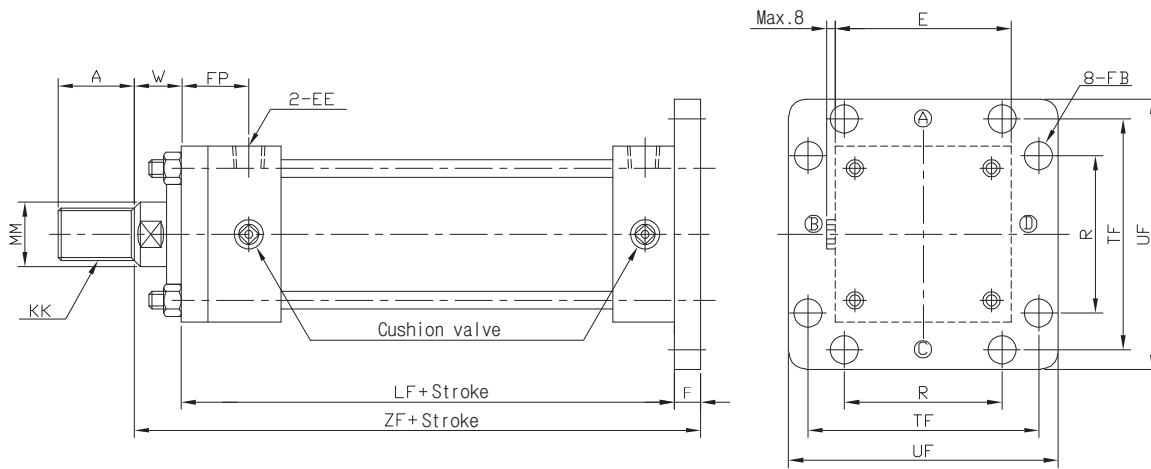

Double rod type (Ø40 ~ Ø160)

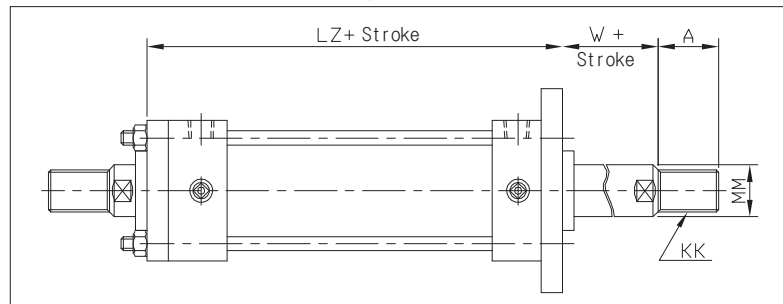

※ For not shown dimensions, refer to SD type (standard type).

Cylinder cover fixing method according to stroke
Unit:mm

Bore size	~1500	1501~2000
Ø80~Ø250	Tie rod type	Tube flange type

Unit : mm

Bore size	Bore size (B type)					Bore size (C type)					E	EE	F	FB	FP	LF	LZ	R	TF	UF	W	ZF
	A	B	D	KK	MM	A	B	D	KK	MM												
Ø40	30	Ø40	21	M20X1.5	Ø22	25	Ø36	17	M16X1.5	Ø18	□65	Rc(PT)3/8	11	Ø11	38	141	166	46	95	118	30	182
Ø50	35	Ø45	24	M24X1.5	Ø28	30	Ø40	20	M20X1.5	Ø22	□76	Rc(PT)1/2	13	Ø14	42	155	182	58	115	145	30	198
Ø63	45	Ø55	30	M30X1.5	Ø35	35	Ø45	24	M24X1.5	Ø28	□90	Rc(PT)1/2	15	Ø18	46	163	194	65	132	165	35	213
Ø80	60	Ø65	41	M39X1.5	Ø45	45	Ø55	30	M30X1.5	Ø35	□110	Rc(PT)3/4	18	Ø18	56	180	218	87	155	190	35	233
Ø100	75	Ø80	50	M48X1.5	Ø55	60	Ø65	41	M39X1.5	Ø45	□135	Rc(PT)3/4	20	Ø22	58	192	232	109	190	230	40	252
Ø125	95	Ø95	65	M64X2	Ø70	75	Ø80	50	M48X1.5	Ø55	□165	Rc(PT)1	24	Ø26	67	220	264	130	224	272	45	289
Ø140	110	Ø105	75	M72X2	Ø80	80	Ø85	60	M56X2	Ø65	□185	Rc(PT)1	26	Ø26	67	230	276	145	250	300	50	306
Ø150	115	Ø110	80	M76X2	Ø85	85	Ø90	60	M60X2	Ø65	□196	Rc(PT)1	28	Ø30	68	240	288	155	270	320	50	318
Ø160	120	Ø115	85	M80X2	Ø90	95	Ø95	65	M64X2	Ø70	□210	Rc(PT)1	31	Ø33	74	253	304	170	285	345	55	339
Ø180	140	Ø125	-	M95X2	Ø100	110	Ø105	75	M72X2	Ø80	□235	Rc(PT)1 1/4	33	Ø33	75	275	-	185	315	375	55	363
Ø200	150	Ø140	-	M100X2	Ø112	120	Ø115	85	M80X2	Ø90	□262	Rc(PT)1 1/2	37	Ø36	85	301	-	206	355	425	55	393
Ø250	195	Ø170	-	M130X2	Ø140	150	Ø140	-	M100X2	Ø112	□325	Rc(PT)2	46	Ø45	106	346	-	250	425	515	65	457

Dimensions-Single Clevis (CA)

70kgf/cm² · 140kgf/cm²

※ Shape varies depending on bore sizes.

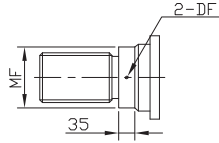
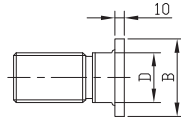

Bore size	MF	DF
Ø100	Ø97	Ø12
Ø110	Ø109	Ø15
Ø140	Ø137	Ø15

D:Width cross flat
(for spanner)

※ To the bore size of Ø100 a hole is placed with the width cross flat.

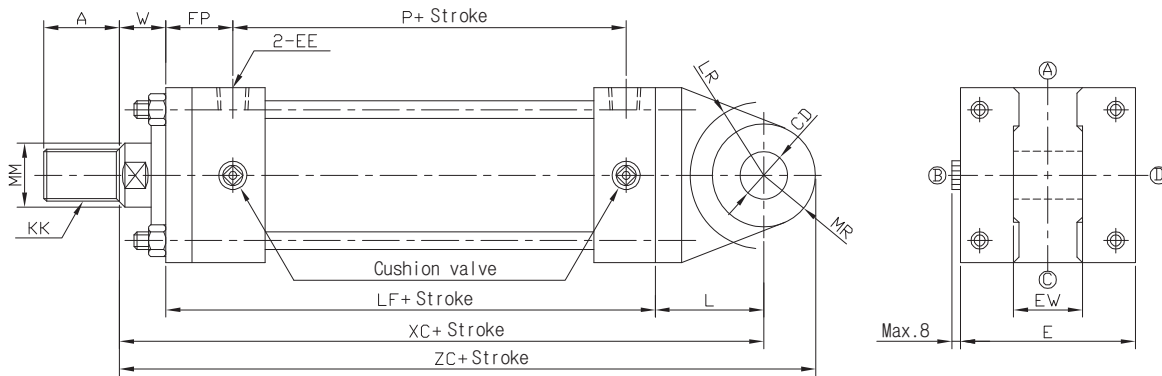

※ For not shown dimensions, refer to SD type (standard type).

Cylinder cover fixing method according to stroke

Unit:mm

Bore size	~1500	1501~2000
Ø80~Ø250	Tie rod type	Tube flange type

Hydraulic
Cylinder

Reference
Data

KP140H

KP210H

KPC70/140H

KPC210H

KTC70HP

KP140HS

KP125/160A

KP35R

KH

Unit : mm

Bore size	Bore size (B type)					Bore size (C type)					CD	E	EE	EW	FP	L	LF	LR	MR	P	W	XC	ZC
	A	B	D	KK	MM	A	B	D	KK	MM													
Ø40	30	Ø40	21	M20X1.5	Ø22	25	Ø36	17	M16X1.5	Ø18	Ø16H9	□65	Rc(PT)3/8	25 ^{-0.1} _{-0.4}	38	38	141	R20	R16	90	30	209	225
Ø50	35	Ø45	24	M24X1.5	Ø28	30	Ø40	20	M20X1.5	Ø22	Ø20H9	□76	Rc(PT)1/2	31.5 ^{-0.1} _{-0.4}	42	45	155	R25	R20	98	30	230	250
Ø63	45	Ø55	30	M30X1.5	Ø35	35	Ø45	24	M24X1.5	Ø28	Ø31.5H9	□90	Rc(PT)1/2	40 ^{-0.1} _{-0.4}	46	63	163	R46	R31.5	102	35	261	292.5
Ø80	60	Ø65	41	M39X1.5	Ø45	45	Ø55	30	M30X1.5	Ø35	Ø31.5H9	□110	Rc(PT)3/4	40 ^{-0.1} _{-0.4}	56	72	180	R52	R31.5	106	35	287	318.5
Ø100	75	Ø80	50	M48X1.5	Ø55	60	Ø65	41	M39X1.5	Ø45	Ø40H9	□135	Rc(PT)3/4	50 ^{-0.1} _{-0.4}	58	84	192	R62	R40	116	40	316	356
Ø125	95	Ø95	65	M64X2	Ø70	75	Ø80	50	M48X1.5	Ø55	Ø50H9	□165	Rc(PT)1	63 ^{-0.1} _{-0.4}	67	100	220	R73	R50	130	45	365	415
Ø140	110	Ø105	75	M72X2	Ø80	80	Ø85	60	M56X2	Ø65	Ø63H9	□185	Rc(PT)1	80 ^{-0.1} _{-0.6}	67	120	230	R91	R63	138	50	400	463
Ø150	115	Ø110	80	M76X2	Ø85	85	Ø90	60	M60X2	Ø65	Ø63H9	□196	Rc(PT)1	80 ^{-0.1} _{-0.6}	68	122	240	R91	R63	146	50	412	475
Ø160	120	Ø115	85	M80X2	Ø90	95	Ø95	65	M64X2	Ø70	Ø71H9	□210	Rc(PT)1	80 ^{-0.1} _{-0.6}	74	137	253	R103	R71	156	55	445	516
Ø180	140	Ø125	-	M95X2	Ø100	110	Ø105	75	M72X2	Ø80	Ø80H9	□235	Rc(PT)1 1/4	100 ^{-0.1} _{-0.6}	75	150	275	R100	R80	172	55	480	560
Ø200	150	Ø140	-	M100X2	Ø112	120	Ø115	85	M80X2	Ø90	Ø90H9	□262	Rc(PT)1 1/2	125 ^{-0.1} _{-0.6}	85	170	301	R115	R90	184	55	526	616
Ø250	195	Ø170	-	M130X2	Ø140	150	Ø140	-	M100X2	Ø112	Ø100H9	□325	Rc(PT)2	125 ^{-0.1} _{-0.6}	106	185	346	R125	R100	200	65	596	696

Dimensions-Double Clevis (CB)

70kgf/cm² · 140kgf/cm²

※ Shape varies depending on bore sizes.

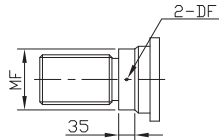
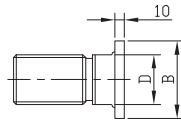

Bore size	MF	DF
Ø100	Ø97	Ø12
Ø110	Ø109	Ø15
Ø140	Ø137	Ø15

D:Width cross flat
(for spanner)

※ To the bore size of Ø100 a hole is placed with the width cross flat.

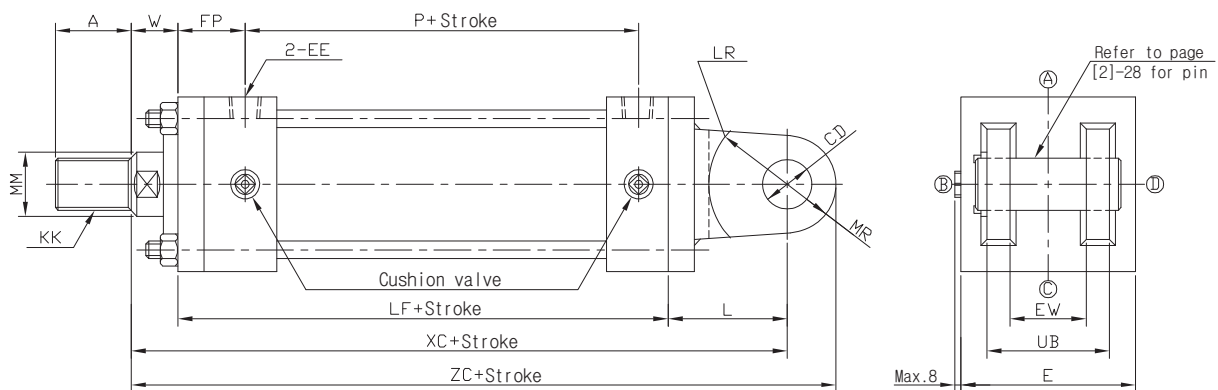

※ For not shown dimensions, refer to SD type(standard type).

Cylinder cover fixing method according to stroke
Unit:mm

Bore size	~1500	1501~2000
Ø80~Ø250	Tie rod type	Tube flange type

Unit : mm

Bore size	Bore size (B type)					Bore size (C type)					CD	E	EE	EW	FP	L	LF	LR	MR	P	UB	W	XC	ZC
	A	B	D	KK	MM	A	B	D	KK	MM														
Ø40	30	Ø40	21	M20X1.5	Ø22	25	Ø36	17	M16X1.5	Ø18	Ø16H9	□65	Rc(PT)3/8	25 ^{+0.4} / _{+0.1}	38	38	141	R20	R16	90	50	30	209	225
Ø50	35	Ø45	24	M24X1.5	Ø28	30	Ø40	20	M20X1.5	Ø22	Ø20H9	□76	Rc(PT)1/2	31.5 ^{+0.4} / _{+0.1}	42	45	155	R25	R20	98	63.5	30	230	250
Ø63	45	Ø55	30	M30X1.5	Ø35	35	Ø45	24	M24X1.5	Ø28	Ø31.5H9	□90	Rc(PT)1/2	40 ^{+0.4} / _{+0.1}	46	63	163	R46	R31.5	102	80	35	261	292.5
Ø80	60	Ø65	41	M39X1.5	Ø45	45	Ø55	30	M30X1.5	Ø35	Ø31.5H9	□110	Rc(PT)3/4	40 ^{+0.4} / _{+0.1}	56	72	180	R52	R31.5	106	80	35	287	318.5
Ø100	75	Ø80	50	M48X1.5	Ø55	60	Ø65	41	M39X1.5	Ø45	Ø40H9	□135	Rc(PT)3/4	50 ^{+0.4} / _{+0.1}	58	84	192	R62	R40	116	100	40	316	356
Ø125	95	Ø95	65	M64X2	Ø70	75	Ø80	50	M48X1.5	Ø55	Ø50H9	□165	Rc(PT)1	63 ^{+0.4} / _{+0.1}	67	100	220	R73	R50	130	126	45	365	415
Ø140	110	Ø105	75	M72X2	Ø80	80	Ø85	60	M56X2	Ø65	Ø63H9	□185	Rc(PT)1	80 ^{+0.6} / _{+0.1}	67	120	230	R91	R63	138	160	50	400	463
Ø150	115	Ø110	80	M76X2	Ø85	85	Ø90	60	M60X2	Ø65	Ø63H9	□196	Rc(PT)1	80 ^{+0.6} / _{+0.1}	68	122	240	R91	R63	146	160	50	412	475
Ø160	120	Ø115	85	M80X2	Ø90	95	Ø95	65	M64X2	Ø70	Ø71H9	□210	Rc(PT)1	80 ^{+0.6} / _{+0.1}	74	137	253	R103	R71	156	160	55	445	516
Ø180	140	Ø125	-	M95X2	Ø100	110	Ø105	75	M72X2	Ø80	Ø80H9	□235	Rc(PT)1 1/4	100 ^{+0.6} / _{+0.1}	75	150	275	R100	R80	172	200	55	480	560
Ø200	150	Ø140	-	M100X2	Ø112	120	Ø115	85	M80X2	Ø90	Ø90H9	□262	Rc(PT)1 1/2	125 ^{+0.6} / _{+0.1}	85	170	301	R115	R90	184	251	55	526	616
Ø250	195	Ø170	-	M130X2	Ø140	150	Ø140	-	M100X2	Ø112	Ø100H9	□325	Rc(PT)2	125 ^{+0.6} / _{+0.1}	106	185	346	R125	R100	200	251	65	596	696

Dimensions-Center Trunnion (TC)

70kgf/cm² · 140kgf/cm²

※ Shape varies depending on bore sizes.

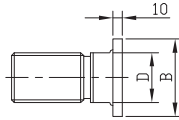

D: Width across flat (for spanner)

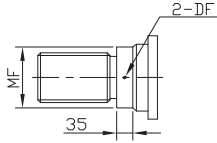

※ To the bore size of Ø100 a hole is placed with the width cross flat.

Bore size	MF	DF
Ø100	Ø97	Ø12
Ø110	Ø109	Ø15
Ø140	Ø137	Ø15

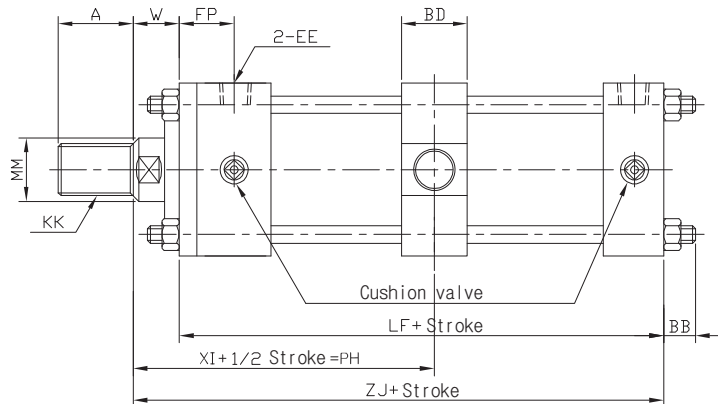
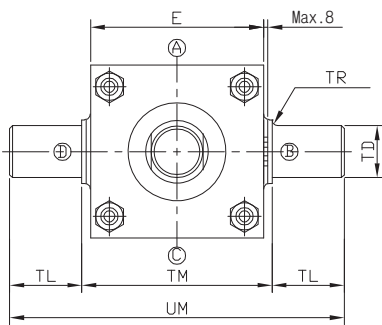

Double rod type (Ø40 ~ Ø160)

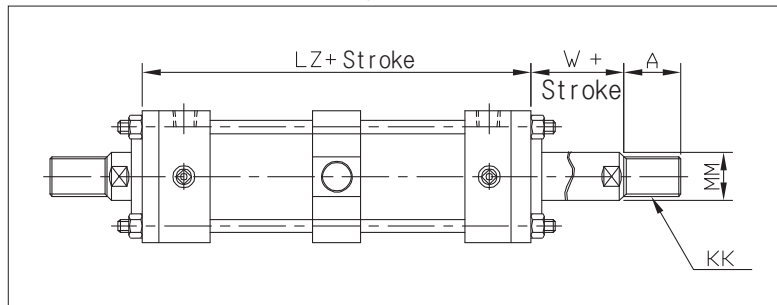

※ For not shown dimensions, refer to SD type (standard type).

Cylinder cover fixing method according to stroke
Unit:mm

Bore size	~1500	1501~2000
Ø80~Ø250	Tie rod type	Tube flange type

Hydraulic Cylinder

Reference Data

KP140H
KP210H
KPC70/140H
KPC210H
KTC70HP
KP140HS
KP125/160A
KP35R
KH

Unit : mm

Bore size	Bore size (B type)					Bore size (C type)					BB	BD	E	EE	FP	LF	LZ	Min. PH	TD	TL	TM	TR	UM	W	XI	ZJ
	A	B	D	KK	MM	A	B	D	KK	MM																
Ø40	30	Ø40	21	M20X1.5	Ø22	25	Ø36	17	M16X1.5	Ø18	15	28	□65	Rc(PT)3/8	38	141	166	105	Ø20e9	20	69 ⁰ _{-0.3}	2	109	30	113	171
Ø50	35	Ø45	24	M24X1.5	Ø28	30	Ø40	20	M20X1.5	Ø22	15	33	□76	Rc(PT)1/2	42	155	182	113.5	Ø25e9	25	85 ⁰ _{-0.35}	2.5	135	30	121	185
Ø63	45	Ø55	30	M30X1.5	Ø35	35	Ø45	24	M24X1.5	Ø28	17	43	□90	Rc(PT)1/2	46	163	194	127.5	Ø31.5e9	31.5	98 ⁰ _{-0.35}	2.5	161	35	132	198
Ø80	60	Ø65	41	M39X1.5	Ø45	45	Ø55	30	M30X1.5	Ø35	23	43	□110	Rc(PT)3/4	56	180	218	140.5	Ø31.5e9	31.5	118 ⁰ _{-0.35}	2.5	181	35	146	215
Ø100	75	Ø80	50	M48X1.5	Ø55	60	Ø65	41	M39X1.5	Ø45	26	53	□135	Rc(PT)3/4	58	192	232	152.5	Ø40e9	40	145 ⁰ _{-0.35}	3	225	40	156	232
Ø125	95	Ø95	65	M64X2	Ø70	75	Ø80	50	M48X1.5	Ø55	30	58	□165	Rc(PT)1	67	220	264	174	Ø50e9	50	175 ⁰ _{-0.46}	3	275	45	177	265
Ø140	110	Ø105	75	M72X2	Ø80	80	Ø85	60	M56X2	Ø65	35	78	□185	Rc(PT)1	67	230	276	191	Ø63e9	63	195 ⁰ _{-0.46}	4	321	50	188	280
Ø150	115	Ø110	80	M76X2	Ø85	85	Ø90	60	M60X2	Ø65	35	78	□196	Rc(PT)1	68	240	288	193	Ø63e9	63	206 ⁰ _{-0.46}	4	332	50	194	290
Ø160	120	Ø115	85	M80X2	Ø90	95	Ø95	65	M64X2	Ø70	35	88	□210	Rc(PT)1	74	253	304	211	Ø71e9	71	218 ⁰ _{-0.46}	4	360	55	207	308
Ø180	140	Ø125	-	M95X2	Ø100	110	Ø105	75	M72X2	Ø80	40	98	□235	Rc(PT)1 1/4	75	275	-	225	Ø80e9	80	243 ⁰ _{-0.46}	4	403	55	216	330
Ø200	150	Ø140	-	M100X2	Ø112	120	Ø115	85	M80X2	Ø90	40	108	□262	Rc(PT)1 1/2	85	301	-	224	Ø90e9	90	272 ⁰ _{-0.52}	5	452	55	232	356
Ø250	195	Ø170	-	M130X2	Ø140	150	Ø140	-	M100X2	Ø112	50	117	□325	Rc(PT)2	106	346	-	287.5	Ø100e9	100	335 ⁰ _{-0.57}	5	535	65	271	411

Dimensions-Rod Side Trunnion (TA)

70kgf/cm² • 140kgf/cm²

※ Shape varies depending on bore sizes.

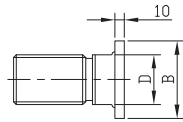

D:Width cross flat
(for spanner)

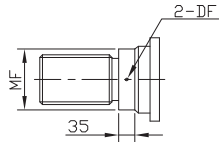

※ To the bore size of Ø100 a hole is placed with the width cross flat.

Bore size	MF	DF
Ø100	Ø97	Ø12
Ø110	Ø109	Ø15
Ø140	Ø137	Ø15

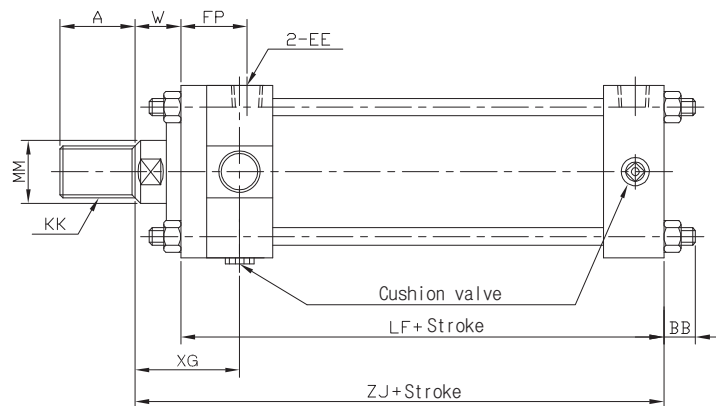
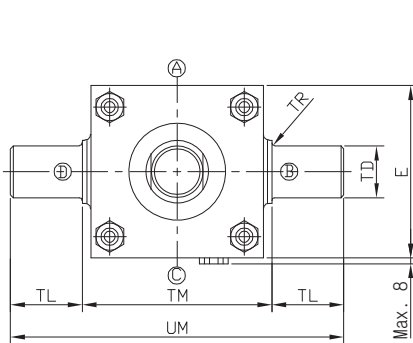

Double rod type (Ø40 ~ Ø160)

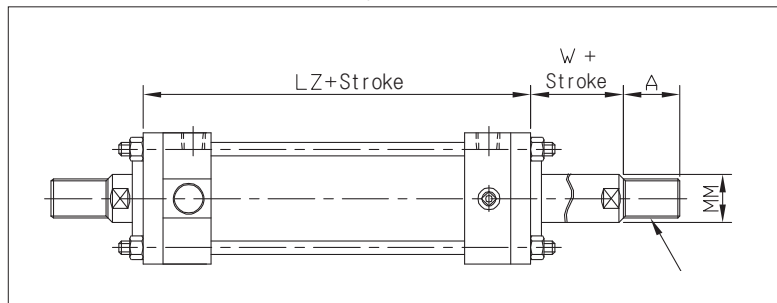

- ※ For not shown dimensions, refer to SD type (standard type).
- ※ Cushion valve and air vent location of TA type is C. (Rod cover)

Cylinder cover fixing method according to stroke
Unit:mm

Bore size	~1500	1501~2000
Ø80~Ø250	Tie rod type	Tube flange type

Unit : mm

Bore size	Bore size (B type)					Bore size (C type)					BB	E	EE	FP	LF	LZ	TD	TL	TM	TR	UM	W	XG	ZJ
	A	B	D	KK	MM	A	B	D	KK	MM														
Ø40	30	Ø40	21	M20X1.5	Ø22	25	Ø36	17	M16X1.5	Ø18	15	□65	Rc(PT)3/8	38	141	166	Ø20e9	20	69 ⁰ _{-0.3}	2	109	30	62	171
Ø50	35	Ø45	24	M24X1.5	Ø28	30	Ø40	20	M20X1.5	Ø22	15	□76	Rc(PT)1/2	42	155	182	Ø25e9	25	85 ⁰ _{-0.35}	2.5	135	30	72	185
Ø63	45	Ø55	30	M30X1.5	Ø35	35	Ø45	24	M24X1.5	Ø28	17	□90	Rc(PT)1/2	46	163	194	Ø31.5e9	31.5	98 ⁰ _{-0.35}	2.5	161	35	74	198
Ø80	60	Ø65	41	M39X1.5	Ø45	45	Ø55	30	M30X1.5	Ø35	23	□110	Rc(PT)3/4	56	180	218	Ø31.5e9	31.5	118 ⁰ _{-0.35}	2.5	181	35	82	215
Ø100	75	Ø80	50	M48X1.5	Ø55	60	Ø65	41	M39X1.5	Ø45	26	□135	Rc(PT)3/4	58	192	232	Ø40e9	40	145 ⁰ _{-0.4}	3	225	40	89	232
Ø125	95	Ø95	65	M64X2	Ø70	75	Ø80	50	M48X1.5	Ø55	30	□165	Rc(PT)1	67	220	264	Ø50e9	50	175 ⁰ _{-0.46}	3	275	45	103	265
Ø140	110	Ø105	75	M72X2	Ø80	80	Ø85	60	M56X2	Ø65	35	□185	Rc(PT)1	67	230	276	Ø63e9	63	195 ⁰ _{-0.46}	4	321	50	108	280
Ø150	115	Ø110	80	M76X2	Ø85	85	Ø90	60	M60X2	Ø65	35	□196	Rc(PT)1	68	240	288	Ø63e9	63	206 ⁰ _{-0.46}	4	332	50	112	290
Ø160	120	Ø115	85	M80X2	Ø90	95	Ø95	65	M64X2	Ø70	35	□210	Rc(PT)1	74	253	304	Ø71e9	71	218 ⁰ _{-0.46}	4	360	55	126	308

Dimensions-Bellows Attached Type (J, K)

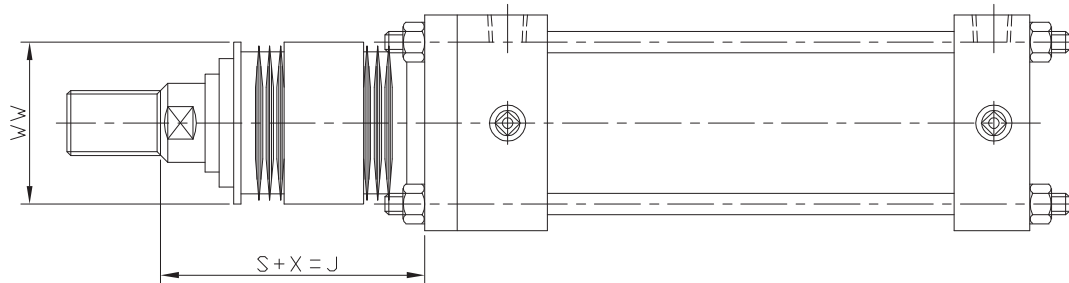

Type	J	K
Material	Nylon Tarpaulin	Neoprene Cloth
Temperature	60°C	110°C

Bore size	Ø40	Ø50	Ø63	Ø80	Ø100	Ø125	Ø140	Ø150	Ø160	Ø180	Ø200	Ø250	
X	45	45	55	55	55	65	65	65	65	65	65	80	
WW	B type	50	63	71	80	100	125	140	140	140	160	180	200
	C type	50	50	63	71	80	125	125	125	125	125	140	180
S	1/3.5xstroke		1/4xstroke			1/5xstroke						1/6x stroke	

- ※ For not shown dimensions, refer to SD type (standard type).
- ※ Dimensions remain the same even when tube flange type mounting is applied.
- ※ When calculating with decimals, please round up.
- ※ SUS band is mounted at bellows at delivery.

Hydraulic Cylinder

Reference Data

KP140H

KP210H

KPC70/140H

KPC210H

KTC70HP

KP140HS

KP125/160A

KP35R

KH

Dimensions-Auto Switch Attached Type

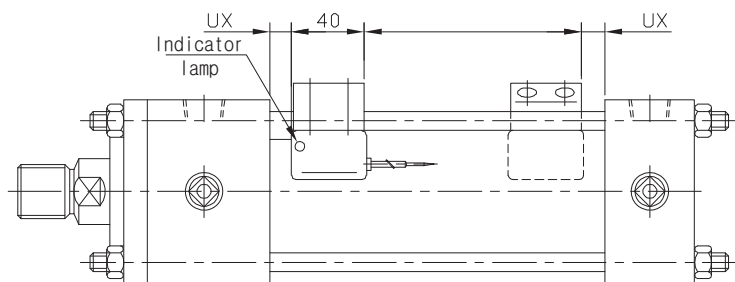
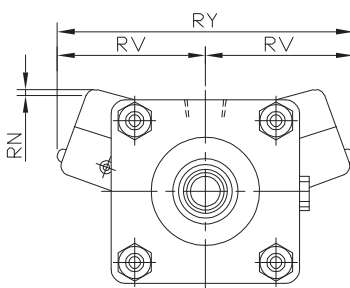

- ※ For not shown dimensions, refer to KP140H series according to cylinder mounting type.

Applicable Auto Switch

D-A54K, D-A56K, D-A64K, D-A90(V)K, DA93(V)K, D-A96(V)K, D-F59K, D-F5PK, D-J59K, D-J51K, D-F9N(V)K, D-F9P(V)K, D-F9B(V)K

Bore size	RN	RY	RV	UX
Ø40	3	99	49.5	28
Ø50	3	110	55	30
Ø63	2	120	60	35
Ø80	6	144	72	37
Ø100	5	159	79.5	45

- ※ Tube material : SUS
- ※ Magnet: Metal magnet

KP210H series



KP210H-FA80B-N100 A B

Features

- High-pressure tie rod type cylinder.
- Double acting hydraulic cylinder for 2100kgf/cm² with bore from Ø40 to Ø160.
- High performance cushion to reduce shock when stopping
- Various mounting styles (SD, LA, FA, FB, CA, CB, TC, TA)

Symbol
Double Acting / Single Rod
Double Acting / Double Rod

Hydraulic Cylinder

Reference Data

KP140H

KP210H

KPC70/140H

KPC210H

KTC70HP

KP140HS

KP125/160A

KP35R

KH

How to Order

KP210H - FA 80 **B** - N 100 A B

① ② ③ ④ ⑤ ⑥ ⑦ ⑧ ⑨ ⑩ ⑪ ⑫

① Series

KP210H	Single rod	210kgf/cm ²
KP210H W	Double rod	
KP210HL	Auto switch (Single rod)	
KP210HL W	Auto switch (Double rod)	

② Seal material

Nil	Nitrile Urethane(Standard)
1	Nitrile rubber
2	Fluoric rubber

③ Mounting style

SD	Standard	CA	Single clevis
LA	Axial angle of foot	CB	Double clevis
FA	Rod side flange	TC	Center trunnion
FB	Head side flange	TA	Rod side trunnion

④ Bore size

40	Ø40
50	Ø50
63	Ø63
80	Ø80
100	Ø100
125	Ø125
140	Ø140
150	Ø150
160	Ø160

⑤ Cushion

N	Without cushion
B	With cushions on both ends
R	With cushion on the rod side
H	With cushion on the head side

⑥ Cylinder stroke

Bore size	Stroke
Ø40, Ø50	1200
Ø63, Ø80	1600
Ø100~Ø160	2000

- * Check buckling, as it varies depending on the mounting style.
- * Contact us for longer stroke.
- * Mounting style for stroke over 801mm at tube size Ø140~Ø160 is flange mounting.

⑦ Port position

A	Standard
B,C,D	Refer to figure below

⑧ Cushion valve position

B	Standard
A,C,D	Refer to figure below

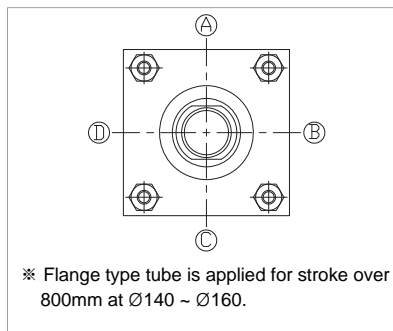

⑨ Bellows

	Material	Max. ambient temperature
Nil	Without bellows	
J	Nylon Tarpaulin	60°C
K	Neoprene Cloth	110°C

⑩ Rod end attachment

Nil	Rod end nut (Standard)
I	Single knuckle joint
Y	Double knuckle joint

⑪ Auto switch

Reed A/S	Model	Solid state A/S	Model
A54	D-A54K	F59	D-F59K
A56	D-A56K	F5P	D-F5PK
A64	D-A64K	J59	D-J59K
A90(V)	D-A90(V)K	J51	D-J51K
A93(V)	D-A93(V)K	F9N	D-F9N(V)K
A96(V)	D-A96(V)K	F9P	D-F9P(V)K
		F9B	D-F9B(V)K

- * Only for auto switch attached type.
- * For more information, refer to Auto Switch Catalogue.

⑫ Number of auto switches

Nil	2pcs
1	1pc
N	Npcs (N:3,4,5...)

- * Only for auto switch attached type.

Specifications

Type	Standard		Auto switch attached	
	KP210H		KP210HL	
Bore size	Ø40, Ø50, Ø63, Ø80, Ø100, Ø125, Ø140, Ø160			
Operating pressure	214.3kgf/cm ² (21.0MPa)			
Max. operating pressure	Head side 250kgf/cm ² (24.5MPa) Rod side 270kgf/cm ² (26.5MPa)			
Proof pressure	321.4kgf/cm ² (31.5MPa)			
Min. operating pressure	Head side ≤4.59kgf/cm ² (0.45MPa), Rod side ≤ 3.06kgf/cm ² (0.3MPa)			
Operating piston speed	8~300mm/sec			
Ambient & fluid temperature	-10 ~ 80 °C		-10 ~ 70 °C	
Cushion	Metal fitting type			
Working oil	Petroleum-based fluid			
Tolerance of thread	KS class 2			
Tolerance of stroke	0~100mm $\begin{matrix} +0.8 \\ 0 \end{matrix}$, 101~250mm $\begin{matrix} +1.0 \\ 0 \end{matrix}$, 251~630mm $\begin{matrix} +1.25 \\ 0 \end{matrix}$ 631~1000mm $\begin{matrix} +1.4 \\ 0 \end{matrix}$, 1001~1600mm $\begin{matrix} +1.6 \\ 0 \end{matrix}$, 1601~2000mm $\begin{matrix} +1.8 \\ 0 \end{matrix}$			
Tube material	Carbon steel for machine structural use		Stainless steel	
Mounting style	SD, LA, FA, FB, CA, CB, TA, TC			

Cushion Length

Unit:mm

Bore size	Ø40 ~ Ø63	Ø80 ~ Ø100
Cushion length	22	25

Bore size	Ø125 ~ Ø150	Ø160
Cushion length	30	35

- * Operating pressure: Max. allowable setting pressure for a relief valve while cylinder is operating.
- * Max. operating pressure: Maximum allowable pressure generated in a cylinder (surge pressure, etc.).
- * Proof pressure: Test pressure for a cylinder can withstand without unreliable performance when returning to operating pressure.
- * Min. operating pressure: Minimum pressure for cylinder installed horizontally and operating without load.
- * A longer thread length (A) is required when lock nut is applied on the end of the piston rod.

Mounting Style

Bore size	Ø40	Ø50	Ø63	Ø80	Ø100	Ø125	Ø140	Ø150	Ø160
Mounting	KP210H	KP210H	KP210H	KP210H	KP210H	KP210H	KP210H	KP210H	KP210H
Axial angle of foot	LA(Hdy.)40	LA(Hdy.)50	LA(Hdy.)63	LA(Hdy.)80	LA(Hdy.)100	LA(Hdy.)125	LA(Hdy.)140	LA(Hdy.)150	LA(Hdy.)160
Flange	FA/FB(Hdy.)40	FA/FB(Hdy.)50	FA/FB(Hdy.)63	FA/FB(Hdy.)80	FA/FB(Hdy.)100	FA/FB(Hdy.)125	FA/FB(Hdy.)140	FA/FB(Hdy.)150	FA/FB(Hdy.)160
Single clevis	CA(Hdy.)40	CA(Hdy.)50	CA(Hdy.)63	CA(Hdy.)80	CA(Hdy.)100	CA(Hdy.)125	CA(Hdy.)140	CA(Hdy.)150	CA(Hdy.)160
Double clevis	CB(Hdy.)40	CB(Hdy.)50	CB(Hdy.)63	CB(Hdy.)80	CB(Hdy.)100	CB(Hdy.)125	CB(Hdy.)140	CB(Hdy.)150	CB(Hdy.)160
Trunnion	TA/TC(Hdy.)40	TA/TC(Hdy.)50	TA/TC(Hdy.)63	TA/TC(Hdy.)80	TA/TC(Hdy.)100	TA/TC(Hdy.)125	TA/TC(Hdy.)140	TA/TC(Hdy.)150	TA/TC(Hdy.)160
Pin of double clevis	CB PIN(Hdy.)40	CB PIN(Hdy.)50	CB PIN(Hdy.)63	CB PIN(Hdy.)80	CB PIN(Hdy.)100	CB PIN(Hdy.)125	CB PIN(Hdy.)140	CB PIN(Hdy.)150	CB PIN(Hdy.)160

Accessory

Bore size	Ø40	Ø50	Ø63	Ø80	Ø100	Ø125	Ø140	Ø150	Ø160
Single knuckle joint	I(Hdy.)40	I(Hdy.)50	I(Hdy.)63	I(Hdy.)80	I(Hdy.)100	I(Hdy.)125	I(Hdy.)140	I(Hdy.)150	I(Hdy.)160
Double knuckle joint	Y(Hdy.)40	Y(Hdy.)50	Y(Hdy.)63	Y(Hdy.)80	Y(Hdy.)100	Y(Hdy.)125	Y(Hdy.)140	Y(Hdy.)150	Y(Hdy.)160
Pin of double knuckle joint	Y PIN(Hdy.)40	Y PIN(Hdy.)50	Y PIN(Hdy.)63	Y PIN(Hdy.)80	Y PIN(Hdy.)100	Y PIN(Hdy.)125	Y PIN(Hdy.)140	Y PIN(Hdy.)150	Y PIN(Hdy.)160
Rod end nut	RN(Hdy.)40	RN(Hdy.)50	RN(Hdy.)63	RN(Hdy.)80	RN(Hdy.)100	RN(Hdy.)125	RN(Hdy.)140	RN(Hdy.)150	RN(Hdy.)160

Mass

Unit : kg

Bore size	Basis mass (SD)	Mounting mass							Accessory			Additional mass per each 1mm of stroke
		LA	FA	FB	CA	CB	TA	TC	Single knuckle joint	Double knuckle joint	Rod end nut	
Ø40	4.44	0.964	0.7	1.0	0.7	0.7	0.4	0.969	1.0	1.2	0.03	0.0122
Ø50	8.06	1.11	1.2	1.9	1.3	1.3	0.4	1.49	1.4	2.2	0.05	0.0202
Ø63	13.2	1.27	1.9	3.7	2.0	2.0	0.6	2.03	2.2	3.7	0.11	0.0293
Ø80	23.6	1.91	2.0	4.7	3.4	3.4	1.0	2.91	4.2	7.7	0.24	0.0451
Ø100	39.6	5.11	4.4	9.7	6.4	6.4	2.1	7.61	8.0	14.6	0.52	0.0738
Ø125	68.5	8.5	10.0	18.6	13.2	13.2	4.0	13.0	31.1	20.5	1.10	0.121
Ø140	92.4	5.2	8.6	21.8	16.5	16.5	5.2	15.1	36.7	24.4	1.44	0.164
Ø160	126	4.7	13.7	30.0	25.6	25.6	7.1	23.7	58.8	41.1	1.93	0.192

Calculation:

Ex.) KP210H-LA100B-N500 A B
Basis mass: 39.6
Additional mass: 0.0738
Stroke: 500mm / LA type: 5.11
39.6+(0.0738 X 500) + 5.11 = 81.61kg

Structure

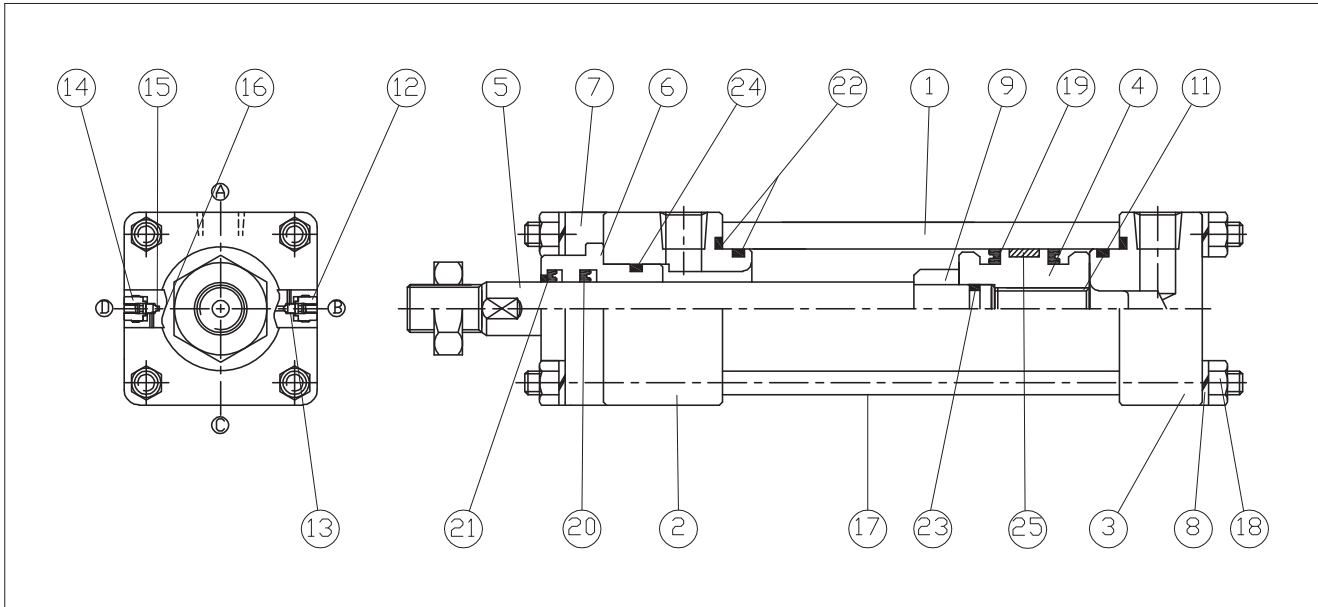

Hydraulic Cylinder

Reference Data

KP140H

KP210H

KPC70/140H

KPC210H

KTC70HP

KP140HS

KP125/160A

Part List

Part no.	Parts	Material	Quantity
1	Cylinder Tube	STKM13C	1
2	Rod Cover	SS400	1
3	Head Cover	SS400	1
4	Piston	S45C	1
5	Piston Rod	S45C	1
6	Bush	SM45C	1
7	Retainer (Bush Cover)	SS400	1
8	Spring Washer	SS400	8
9	Cushion Ring	S45C	1

Part no.	Parts	Material	Quantity
11	Set Screw	SCM435	1
12	Cushion Body	SUM24L	2
13	Cushion Needle	SUM24L	2
14	Check Body	SUM24L	2
15	Coil Spring	SUP	2
16	Steel Ball	SUJ2	2
17	Tie Rod	SM45C	4
18	Hex Nut (2 Kinds)	SM45C	8

KP35R

KH

Packing List

Part no.	19	20	21	22	23	24		
Part	Piston Packing	Rod Packing	B.U.R	Dust Seal	T/O-Ring	B.U.R	Rod O-Ring	Bush O-Ring
Quantity	2	1	1	1	2	2	1	1
Material	Urethane	Urethane	PTFE	Urethane	NBR	PTFE	NBR	NBR
Bore size	Type	Type	Type	Type	Type	Type	Type	Type
Ø40	40x30x16	22x30x5	22x30x2	22x30x4.5x6	G40	-	P-14	G30
Ø50	50x34x18.4	28x35.5x5	28x35.5x3	28x36x4.5/6	G45	For G45	P-18	For P-18
Ø63	63x47x18.4	35x45x6	35x45x3	35x43x5/6.5	G58	For G58	P-22	For P-22
Ø80	80x60x22.4	45x55x6	45x55x3	45x53x5x6.5	G75	For G75	G25	G55
Ø100	100x75x22.4	55x65x6	55x65x3	55x63x5x6.5	G95	For G95	G40	G65
Ø125	125x100x25.4	70x80x6	70x80x3	70x80x6/8	G120	For G120	G50	G85
Ø140	140x115x25.4x9.5	80x90x6	80x90x3	80x90x6/8	G135	For G135	G60	G95
Ø160	160x135x25.4	90x105x9	90x105x3	90x100x6/8	G150	For G150	G65	G115

Dimensions-Standard (SD)

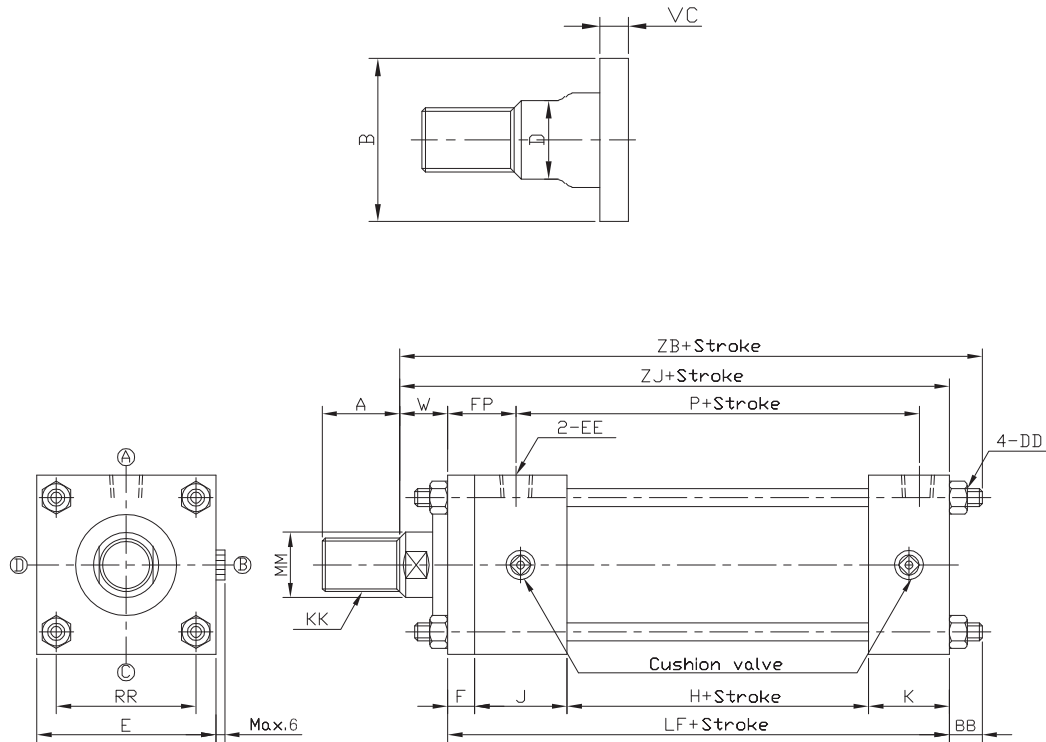

Double Rod Type

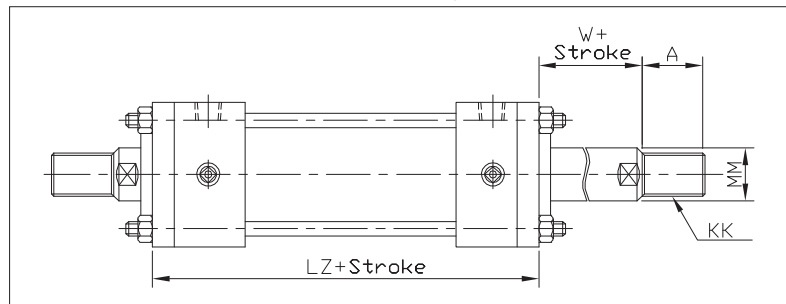

※ Flange type tube is applied for stroke over 800mm at Ø140 - Ø160.

Unit : mm

Bore size	A	B	BB	D	DD	E	EE	F	FP	H	J	K	KK	LF	LZ	MM	P	RR	VC	W	ZB	ZJ
Ø40	25	Ø40	17	19	M12x1.5	□70	Rc(PT)3/8	13	43	64	47	32	M20x1.5	156	183	Ø22	98	□50	11	30	203	186
Ø50	30	Ø46	18	25	M14x1.5	□85	Rc(PT)1/2	15	48	68	52	37	M24x1.5	172	202	Ø28	106	□62	14	30	220	202
Ø63	35	Ø55	21	30	M16x1.5	□100	Rc(PT)1/2	18	56	75	57	37	M30x1.5	187	225	Ø35	113	□74	15	35	243	222
Ø80	45	Ø65	23	41	M18x1.5	□125	Rc(PT)3/4	24	69	85	67	42	M39x1.5	218	267	Ø45	129	□92	9	35	276	253
Ø100	55	Ø80	29	50	M22x1.5	□160	Rc(PT)3/4	26	71	95	67	42	M48x1.5	230	281	Ø55	139	□120	14	40	299	270
Ø125	75	Ø95	35	65	M27x1.5	□190	Rc(PT)1	33	83	105	77	52	M64x2	267	325	Ø71	159	□145	13	45	347	312
Ø140	80	Ø105	39	75	M30x1.5	□215	Rc(PT)1	36	86	110	77	52	M72x2	275	336	Ø80	164	□165	14	50	364	325
Ø160	90	Ø120	40	85	M33x1.5	□240	Rc(PT)1	41	94	124	80	59	M80x2	304	366	Ø90	186	□185	14	55	399	359

Dimensions-Axial Angle of Foot (LA)

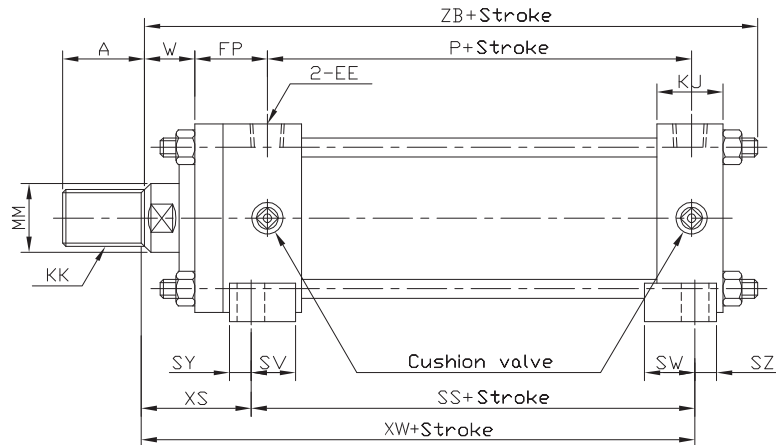
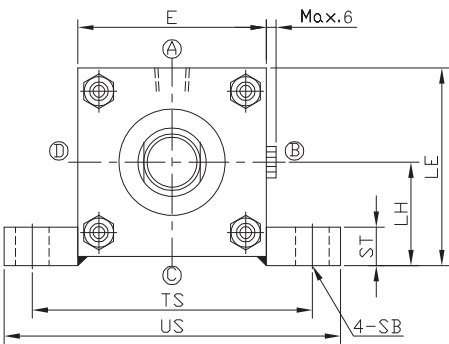

Double Rod Type

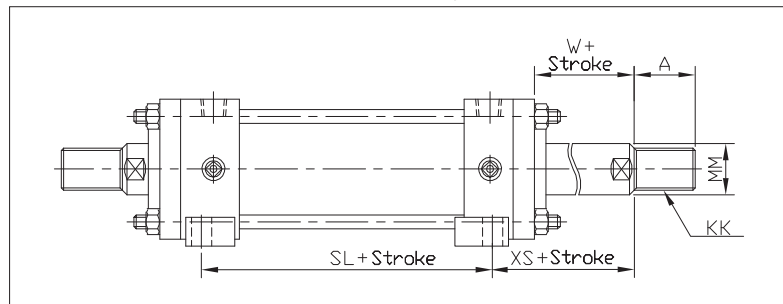

※ For not shown dimensions, refer to SD type (standard type).
 ※ Flange type tube is applied for stroke over 800mm at $\varnothing 140 - \varnothing 160$.

Hydraulic Cylinder

Reference Data

KP140H

KP210H

KPC70/140H

KPC210H

KTC70HP

KP140HS

KP125/160A

KP35R

KH

Unit : mm

Bore size	A	E	EE	FP	KK	KJ	LE	LH	MM	P	SB	SL	SS	ST	SV	SW	SY	SZ	TS	US	W	XS	XW	ZB
$\varnothing 40$	25	□70	Rc(PT)3/8	43	M20x1.5	32	77	42±0.15	$\varnothing 22$	98	$\varnothing 11$	125	111	15	31	16	16	16	98	122	30	59	170	203
$\varnothing 50$	30	□85	Rc(PT)1/2	48	M24x1.5	37	97.5	55±0.15	$\varnothing 28$	106	$\varnothing 14$	136	120	20	34	18	18	19	118	145	30	63	183	220
$\varnothing 63$	35	□100	Rc(PT)1/2	56	M30x1.5	37	113	63±0.15	$\varnothing 35$	113	$\varnothing 18$	153	132	25	39	18	18	19	140	175	35	71	203	243
$\varnothing 80$	45	□125	Rc(PT)3/4	69	M39x1.5	42	137.5	75±0.25	$\varnothing 45$	129	$\varnothing 22$	177	152	30	46	21	21	21	175	210	35	80	232	276
$\varnothing 100$	55	□160	Rc(PT)3/4	71	M48x1.5	42	165	85±0.25	$\varnothing 55$	139	$\varnothing 26$	183	162	35	44	23	23	24	215	260	40	89	251	299
$\varnothing 125$	75	□190	Rc(PT)1	83	M64x2	52	200	105±0.25	$\varnothing 71$	159	$\varnothing 33$	203	182	45	49	28	28	29	270	330	45	106	288	347
$\varnothing 140$	80	□215	Rc(PT)1	86	M72x2	52	219.5	112±0.25	$\varnothing 80$	164	$\varnothing 33$	208	187	45	49	28	28	29	280	335	50	114	301	364
$\varnothing 160$	90	□240	Rc(PT)1	94	M80x2	59	245	125±0.25	$\varnothing 90$	186	$\varnothing 36$	222	212	50	49	31	31	31	315	375	55	127	339	399

Dimensions-Rod Side Flange (FA)

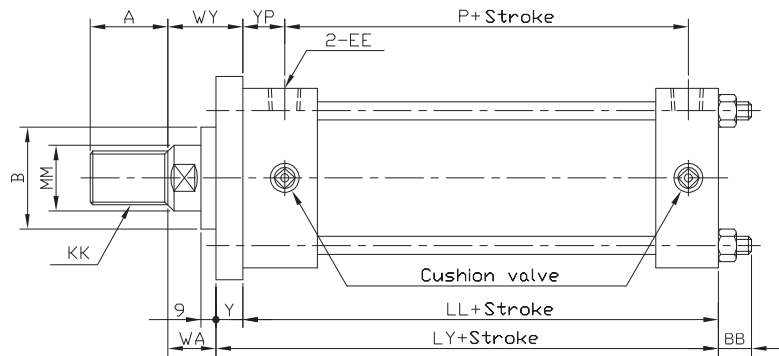
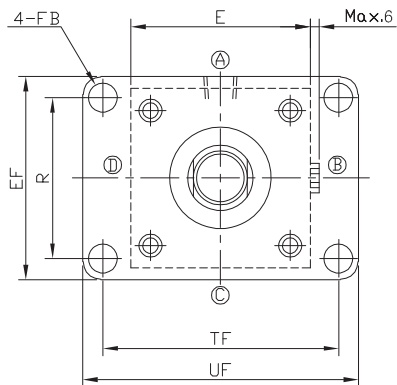

Double Rod Type

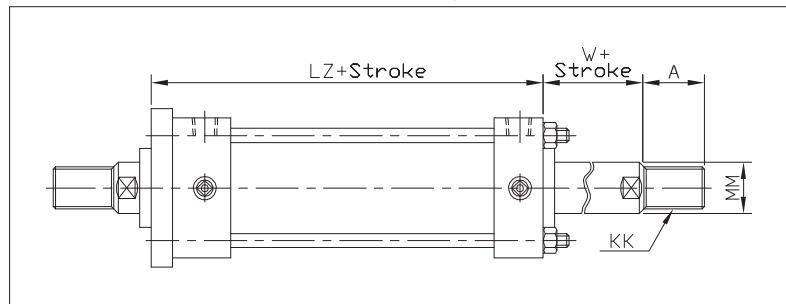

※ For not shown dimensions, refer to SD type (standard type).
 ※ Flange type tube is applied for stroke over 800mm at $\varnothing 140 - \varnothing 160$.

Unit : mm

Bore size	A	B	BB	E	EE	EF	FB	KK	LL	LY	LZ	MM	P	R	TF	UF	W	WA	WY	Y	YP
$\varnothing 40$	25	$\varnothing 40$	17	$\square 70$	Rc(PT)3/8	73	$\varnothing 11$	M20x1.5	143	158	185	$\varnothing 22$	98	50	98	122	30	28	43	15	30
$\varnothing 50$	30	$\varnothing 46$	18	$\square 85$	Rc(PT)1/2	88	$\varnothing 14$	M24x1.5	157	177	207	$\varnothing 28$	106	60	118	145	30	25	45	20	33
$\varnothing 63$	35	$\varnothing 55$	21	$\square 100$	Rc(PT)1/2	106	$\varnothing 18$	M30x1.5	169	193	231	$\varnothing 35$	113	73	140	175	35	29	53	24	38
$\varnothing 80$	45	$\varnothing 65$	23	$\square 125$	Rc(PT)3/4	130	$\varnothing 22$	M39x1.5	194	218	267	$\varnothing 45$	129	90	175	210	35	35	59	24	45
$\varnothing 100$	55	$\varnothing 80$	29	$\square 160$	Rc(PT)3/4	165	$\varnothing 26$	M48x1.5	204	235	286	$\varnothing 55$	139	115	215	260	40	35	66	31	45
$\varnothing 125$	75	$\varnothing 95$	35	$\square 190$	Rc(PT)1	205	$\varnothing 33$	M64x2	234	271	329	$\varnothing 71$	159	145	270	330	45	41	78	37	50
$\varnothing 140$	80	$\varnothing 105$	39	$\square 215$	Rc(PT)1	218	$\varnothing 33$	M72x2	239	280	341	$\varnothing 80$	164	160	280	335	50	45	86	41	50
$\varnothing 160$	90	$\varnothing 120$	40	$\square 240$	Rc(PT)1	243	$\varnothing 36$	M80x2	263	309	371	$\varnothing 90$	186	180	315	375	55	50	96	46	53

Dimensions-Head Side Flange (FB)

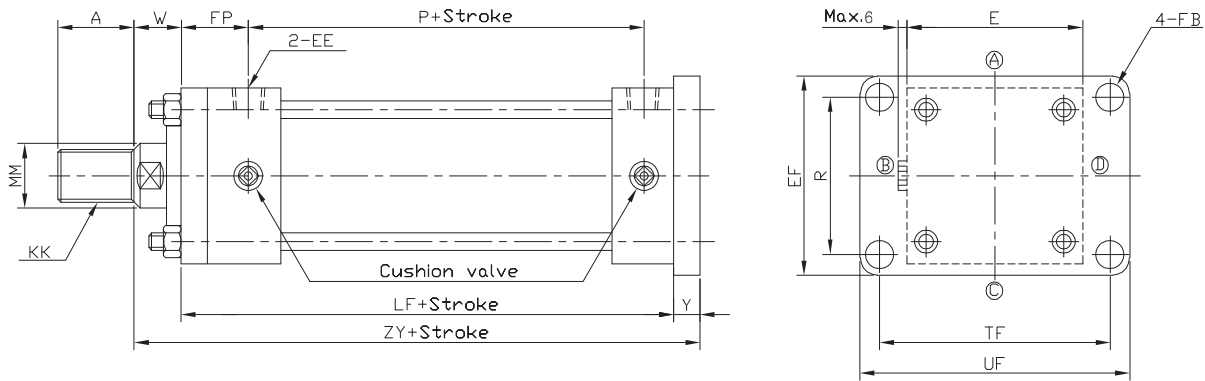

Double Rod Type

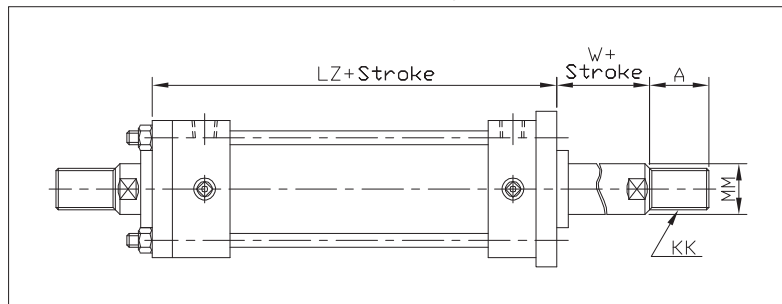

※ For not shown dimensions, refer to SD type (standard type).
 ※ Flange type tube is applied for stroke over 800mm at $\varnothing 140 - \varnothing 160$.

Hydraulic Cylinder
Reference Data
KP140H
KP210H
KPC70/140H
KPC210H
KTC70HP
KP140HS
KP125/160A
KP35R
KH

Unit : mm

Bore size	A	E	EE	EF	FB	FP	KK	LF	LZ	MM	P	R	TF	UF	W	Y	ZY
$\varnothing 40$	25	□70	Rc(PT)3/8	73	$\varnothing 11$	43	M20x1.5	156	185	$\varnothing 22$	98	50	98	122	30	15	201
$\varnothing 50$	30	□85	Rc(PT)1/2	88	$\varnothing 14$	48	M24x1.5	172	207	$\varnothing 28$	106	60	118	145	30	20	222
$\varnothing 63$	35	□100	Rc(PT)1/2	106	$\varnothing 18$	56	M30x1.5	187	231	$\varnothing 35$	113	73	140	175	35	24	246
$\varnothing 80$	45	□125	Rc(PT)3/4	130	$\varnothing 22$	69	M39x1.5	218	267	$\varnothing 45$	129	90	175	210	35	24	277
$\varnothing 100$	55	□160	Rc(PT)3/4	165	$\varnothing 26$	71	M48x1.5	230	286	$\varnothing 55$	139	115	215	260	40	31	301
$\varnothing 125$	75	□190	Rc(PT)1	205	$\varnothing 33$	83	M64x2	267	329	$\varnothing 71$	159	145	270	330	45	37	349
$\varnothing 140$	80	□215	Rc(PT)1	218	$\varnothing 33$	86	M72x2	275	341	$\varnothing 80$	164	160	280	335	50	41	366
$\varnothing 160$	90	□240	Rc(PT)1	243	$\varnothing 36$	94	M80x2	304	371	$\varnothing 90$	186	180	315	375	55	46	405

Dimensions-Single Clevis (CA)

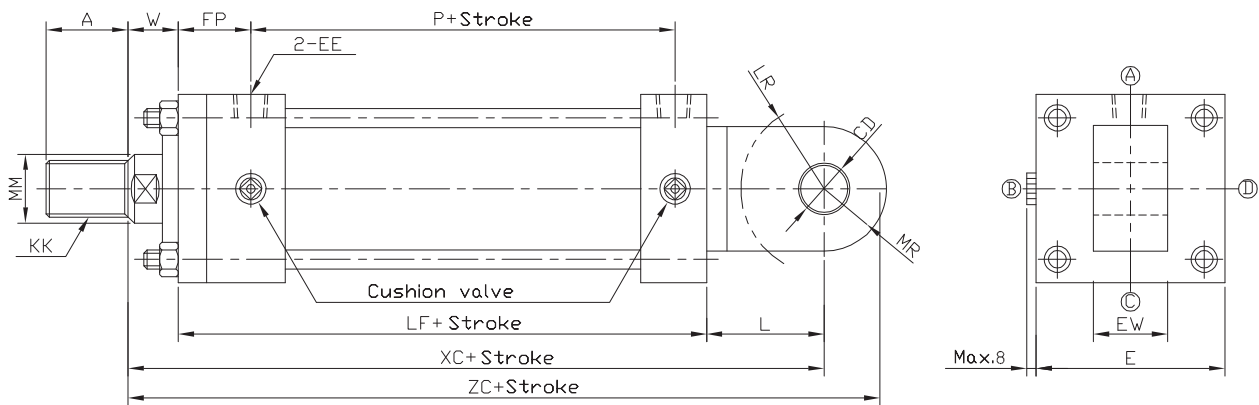

※ For not shown dimensions, refer to SD type (standard type).
 ※ Flange type tube is applied for stroke over 800mm at $\varnothing 140 \sim \varnothing 160$.

Unit : mm

Bore size	A	CD	E	EE	EW	FP	KK	L	LF	LR	MM	MR	P	W	XC	ZC
$\varnothing 40$	25	$\varnothing 20^{H9}$	$\square 70$	Rc(PT)3/8	32 ^{-0.1} _{-0.4}	43	M20x1.5	35	156	R25	$\varnothing 22$	R25	98	30	221	246
$\varnothing 50$	30	$\varnothing 25^{H9}$	$\square 85$	Rc(PT)1/2	36 ^{-0.1} _{-0.4}	48	M24x1.5	45	172	R32	$\varnothing 28$	R30	106	30	247	277
$\varnothing 63$	35	$\varnothing 31.5^{H9}$	$\square 100$	Rc(PT)1/2	40 ^{-0.1} _{-0.4}	56	M30x1.5	55	187	R40	$\varnothing 35$	R35	113	35	277	312
$\varnothing 80$	45	$\varnothing 40^{H9}$	$\square 125$	Rc(PT)3/4	50 ^{-0.1} _{-0.4}	69	M39x1.5	70	218	R50	$\varnothing 45$	R40	129	35	323	363
$\varnothing 100$	55	$\varnothing 50^{H9}$	$\square 160$	Rc(PT)3/4	63 ^{-0.1} _{-0.4}	71	M48x1.5	80	230	R63	$\varnothing 55$	R50	139	40	350	400
$\varnothing 125$	75	$\varnothing 63^{H9}$	$\square 190$	Rc(PT)1	80 ^{-0.1} _{-0.6}	83	M64x2	105	267	R79	$\varnothing 71$	R63	159	45	417	480
$\varnothing 140$	80	$\varnothing 71^{H9}$	$\square 215$	Rc(PT)1	80 ^{-0.1} _{-0.6}	86	M72x2	115	275	R89	$\varnothing 80$	R71	164	50	440	511
$\varnothing 160$	90	$\varnothing 80^{H9}$	$\square 240$	Rc(PT)1	100 ^{-0.1} _{-0.6}	94	M80x2	125	304	R100	$\varnothing 90$	R80	186	55	484	564

Dimensions-Double Clevis (CB)

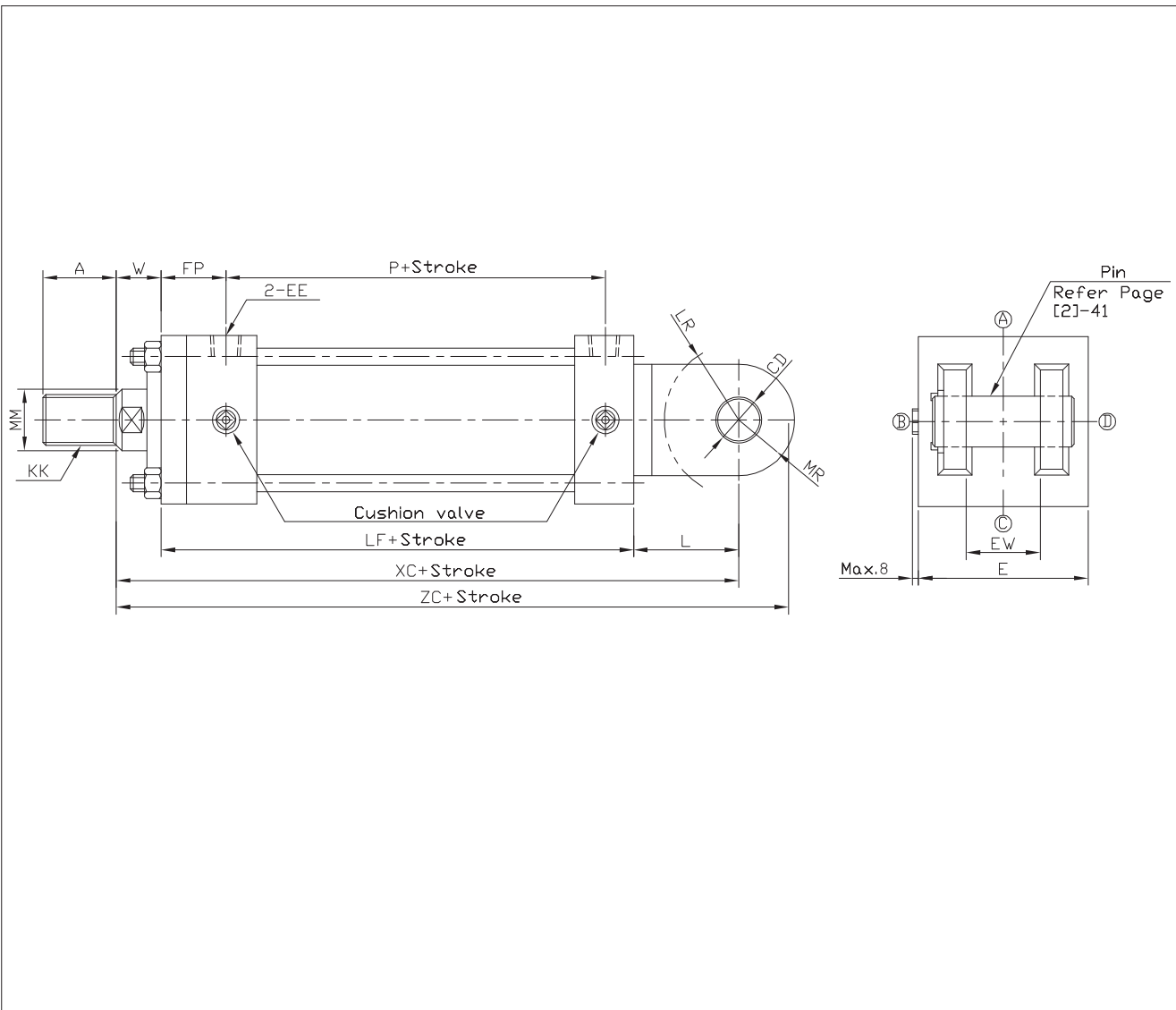

※ For not shown dimensions, refer to SD type(standard type).
 ※ Flange type tube is applied for stroke over 800mm at Ø140 ~ Ø160.

Hydraulic Cylinder
Reference Data
KP140H
KP210H
KPC70/140H
KPC210H
KTC70HP
KP140HS
KP125/160A
KP35R
KH

Unit : mm

Bore size	A	CD	E	EE	EW	FP	KK	L	LF	LR	MM	MR	P	W	XC	ZC
Ø40	25	Ø20 ^{H9}	□70	Rc(PT)3/8	32 ^{+0.4/+0.1}	43	M20x1.5	35	156	R25	Ø22.4	R25	98	30	221	246
Ø50	30	Ø25 ^{H9}	□85	Rc(PT)1/2	36 ^{+0.4/+0.1}	48	M24x1.5	45	172	R32	Ø28	R30	106	30	247	277
Ø63	35	Ø31.5 ^{H9}	□100	Rc(PT)1/2	40 ^{+0.4/+0.1}	56	M30x1.5	55	187	R40	Ø35.5	R35	113	35	277	312
Ø80	45	Ø40 ^{H9}	□125	Rc(PT)3/4	50 ^{+0.4/+0.1}	69	M39x1.5	70	218	R50	Ø45	R40	129	35	323	363
Ø100	55	Ø50 ^{H9}	□160	Rc(PT)3/4	63 ^{+0.4/+0.1}	71	M48x1.5	80	230	R63	Ø56	R50	139	40	350	400
Ø125	75	Ø63 ^{H9}	□190	Rc(PT)1	80 ^{+0.6/+0.1}	83	M64x2	105	267	R79	Ø71	R63	159	45	417	480
Ø140	80	Ø71 ^{H9}	□215	Rc(PT)1	80 ^{+0.6/+0.1}	86	M72x2	115	275	R89	Ø80	R71	164	50	440	511
Ø160	90	Ø80 ^{H9}	□240	Rc(PT)1	100 ^{+0.6/+0.1}	94	M80x2	125	304	R100	Ø90	R80	186	55	484	564

Dimensions-Center Trunnion (TC)

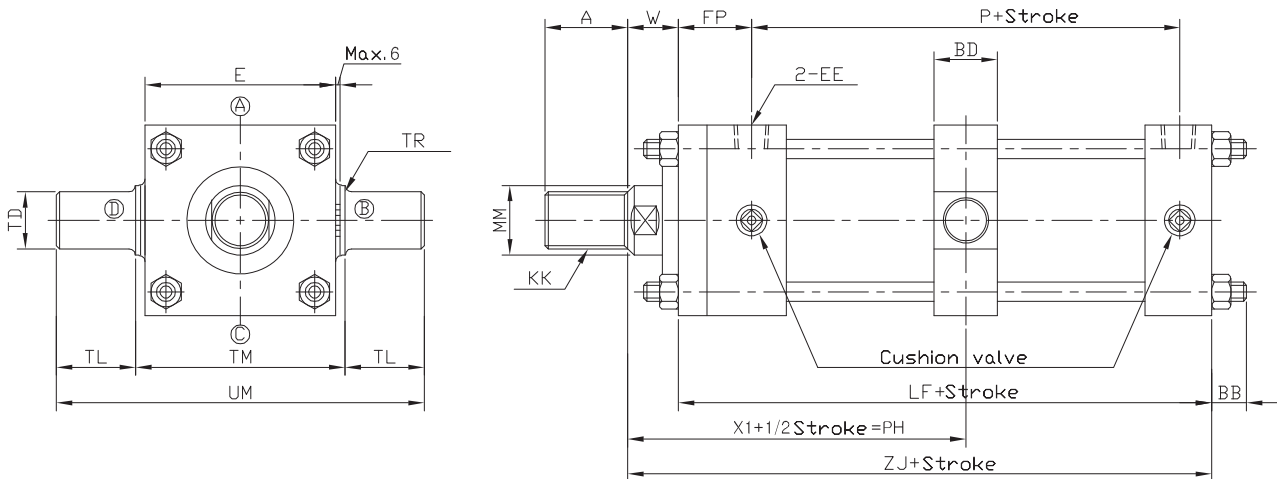

Double Rod Type

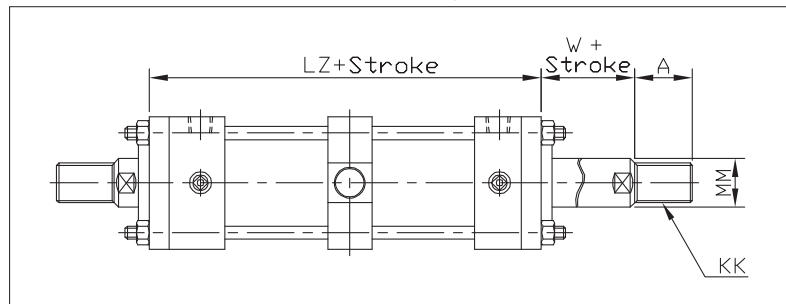

※ For not shown dimensions, refer to SD type (standard type).
 ※ Flange type tube is applied for stroke over 800mm at Ø140 - Ø160.

Unit : mm

Bore size	A	BB	BD	E	EE	FP	KK	LF	LZ	MM	P	Min. PH	TL	TM	TD	TR	UM	W	X1	ZJ
Ø40	25	17	33	□70	Rc(PT)3/8	43	M20×1.5	156	183	Ø22	98	107	25	73 ⁰ _{-0.3}	Ø25 ⁶⁹	2.5	123	30	122	186
Ø50	30	18	33	□85	Rc(PT)1/2	48	M24×1.5	172	202	Ø28	106	114	25	88 ⁰ _{-0.35}	Ø25 ⁶⁹	2.5	138	30	131	202
Ø63	35	21	43	□100	Rc(PT)1/2	56	M30×1.5	187	225	Ø35	113	132	31.5	106 ⁰ _{-0.35}	Ø31.5 ⁶⁹	2.5	169	35	148	222
Ø80	45	23	53	□125	Rc(PT)3/4	69	M39×1.5	218	267	Ø45	129	153	40	128 ⁰ _{-0.4}	Ø40 ⁶⁹	3	208	35	169	253
Ø100	55	29	63	□160	Rc(PT)3/4	71	M48×1.5	230	281	Ø55	139	165	50	170 ⁰ _{-0.4}	Ø50 ⁶⁹	3	270	40	181	270
Ø125	75	35	78	□190	Rc(PT)1	83	M64×2	267	325	Ø71	159	219	63	205 ⁰ _{-0.46}	Ø63 ⁶⁹	4	331	45	208	312
Ø140	80	39	88	□215	Rc(PT)1	86	M72×2	275	336	Ø80	164	232	71	225 ⁰ _{-0.46}	Ø71 ⁶⁹	4	367	50	218	325
Ø160	90	40	98	□240	Rc(PT)1	94	M80×2	304	366	Ø90	186	253	80	255 ⁰ _{-0.52}	Ø80 ⁶⁹	4	415	55	242	359

Dimensions-Rod Side Trunnion (TA)

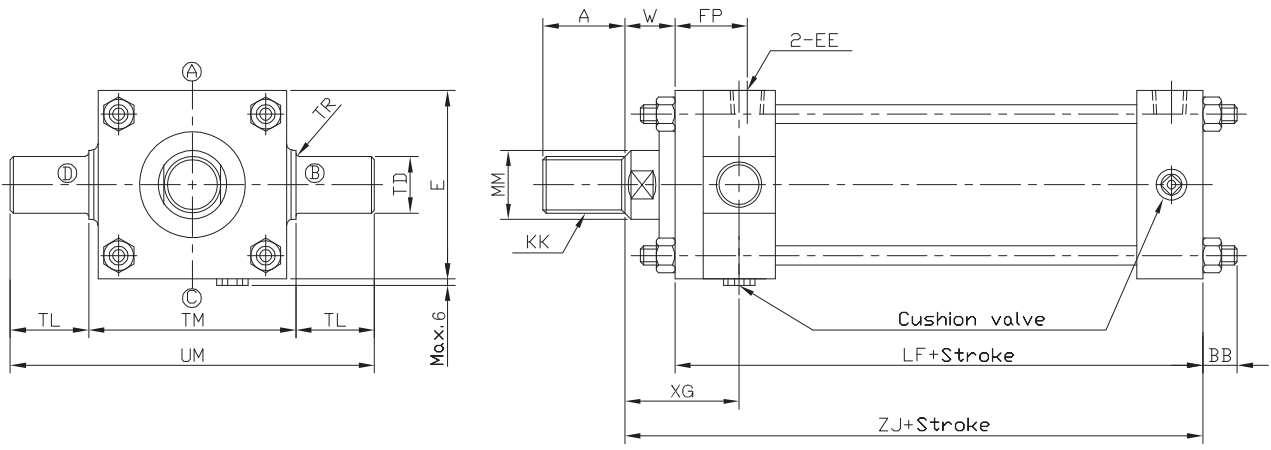

Double Rod Type

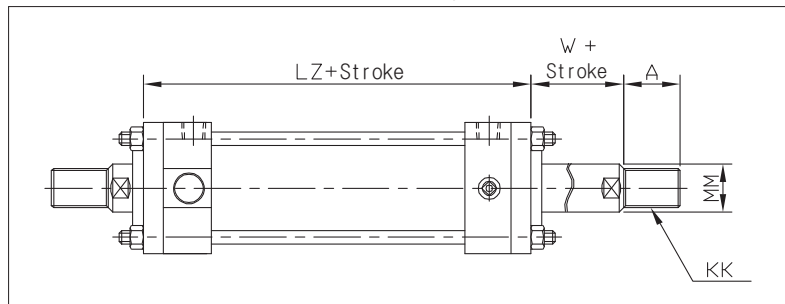

※ For not shown dimensions, refer to SD type (standard type).
 ※ Flange type tube is applied for stroke over 800mm at Ø140 - Ø160.

Unit : mm

Bore size	A	BB	E	EE	FP	KK	LF	LZ	MM	TD	TL	TM	TR	UM	W	XG	ZJ
Ø40	25	17	□70	Rc(PT)3/8	43	M20×1.5	156	183	Ø22.4	Ø25 ^{±0.09}	25	73 ^{0 -0.3}	2.5	123	30	66	186
Ø50	30	18	□85	Rc(PT)1/2	48	M24×1.5	172	202	Ø28	Ø25 ^{±0.09}	25	88 ^{0 -0.35}	2.5	138	30	71	202
Ø63	35	21	□100	Rc(PT)1/2	56	M30×1.5	187	225	Ø35.5	Ø31.5 ^{±0.09}	31.5	106 ^{0 -0.35}	2.5	169	35	81	222
Ø80	45	23	□125	Rc(PT)3/4	69	M39×1.5	218	267	Ø45	Ø40 ^{±0.09}	40	128 ^{0 -0.4}	3	208	35	92	253
Ø100	55	29	□160	Rc(PT)3/4	71	M48×1.5	230	281	Ø56	Ø50 ^{±0.09}	50	170 ^{0 -0.4}	3	270	40	99	270
Ø125	75	35	□190	Rc(PT)1	83	M64×2	267	325	Ø71	Ø63 ^{±0.09}	63	205 ^{0 -0.46}	4	331	45	116	312
Ø140	80	39	□215	Rc(PT)1	99	M72×2	288	349	Ø80	Ø71 ^{±0.09}	71	225 ^{0 -0.46}	4	367	50	131	325
Ø160	90	40	□240	Rc(PT)1	114	M80×2	324	386	Ø90	Ø80 ^{±0.09}	80	255 ^{0 -0.52}	4	415	55	146	359

Hydraulic Cylinder

Reference Data

KP140H

KP210H

KPC70/140H

KPC210H

KTC70HP

KP140HS

KP125/160A

KP35R

KH

Dimensions- Bellows Attached Type (J, K)

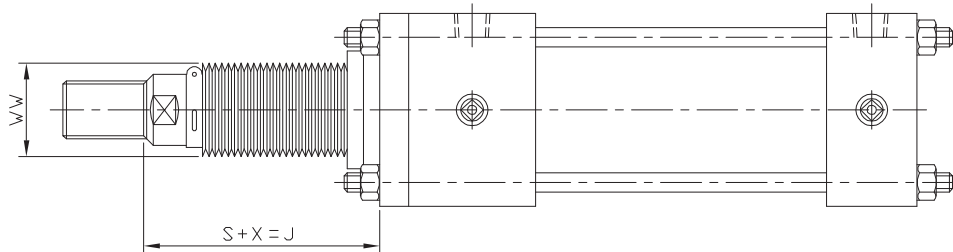

Type	J	K	Bore size	Ø40	Ø50	Ø63	Ø80	Ø100	Ø125	Ø140	Ø160	
Material	Nylon Tarpaulin	Neoprene Cloth	WW	Ø50	Ø63	Ø71	Ø80	Ø100	Ø125	Ø125	Ø140	
Temperature	60°C	110°C	X	FA type	45	45	55	55	55	65	65	65
				All types accept FA	47	50	61	55	60	69	70	70
			S	1/3.5 x Stroke			1/4 x Stroke			1/5 x Stroke		

Dimensions-Accessory

Single Knuckle Joint

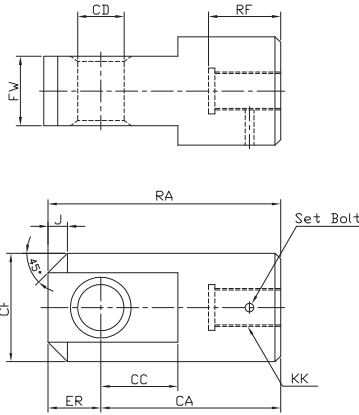

Unit : mm

Part no.	CA	CC	CD	CF	CP	CT	CW	CV	ER	FW	KK	RA	RF	J
KP210H I(Hdy.)40	70	28	∅20 ^{H10}	∅49	76.5	63.5	16	8	25	31.5 ^{-0.1/-0.4}	M20x1.5	95	32	10
KP210H I(Hdy.)50	85	35	∅25 ^{H10}	∅55	84.5	71.5	18	8	30	35.5 ^{-0.1/-0.4}	M24x1.5	115	35	12
KP210H I(Hdy.)63	115	43	∅31.5 ^{H10}	∅62	93	80	20	8	35	40 ^{-0.1/-0.4}	M30x1.5	150	47	15
KP210H I(Hdy.)80	145	55	∅40 ^{H10}	∅79	117	100	25	12	40	50 ^{-0.1/-0.4}	M39x1.5	185	62	20
KP210H I(Hdy.)100	180	65	∅50 ^{H10}	∅100	143	126	31.5	12	50	63 ^{-0.1/-0.4}	M48x1.5	230	77	30
KP210H I(Hdy.)125	225	85	∅63 ^{H10}	∅130	183	160	40	18	65	80 ^{-0.1/-0.6}	M64x2	290	82	30
KP210H I(Hdy.)140	225	85	∅71 ^{H10}	∅130	183	160	40	18	65	80 ^{-0.1/-0.6}	M72x2	290	87	30

Double Knuckle Joint

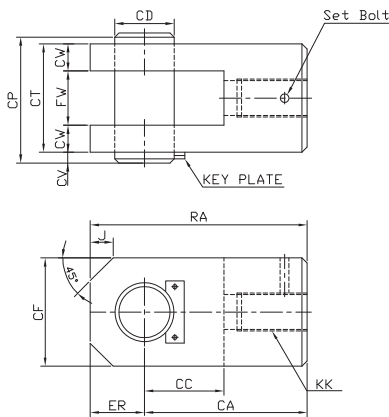

Unit : mm

Part no.	CA	CC	CD	CF	CP	CT	CW	CV	ER	FW	KK	RA	RF	J
KP210H Y(Hdy.)40	70	32	∅20 ^{H10/f8}	40	76.5	63.5	16	8	20	31.5 ^{+0.4/+0.1}	M20x1.5	90	32	10
KP210H Y(Hdy.)50	85	45	∅25 ^{H10/f8}	50	85	71.5	18	8	25	35.5 ^{+0.4/+0.1}	M24x1.5	110	35	12
KP210H Y(Hdy.)63	115	50	∅31.5 ^{H10/f8}	60	93	80	20	8	30	40 ^{+0.4/+0.1}	M30x1.5	145	47	15
KP210H Y(Hdy.)80	145	60	∅40 ^{H10/f8}	80	117	100	25	12	40	50 ^{+0.4/+0.1}	M39x1.5	185	62	20
KP210H Y(Hdy.)100	180	70	∅50 ^{H10/f8}	100	143	126	31.5	12	50	63 ^{+0.4/+0.1}	M48x1.5	230	77	30
KP210H Y(Hdy.)125	225	90	∅63 ^{H10/f8}	120	183	160	40	18	65	80 ^{+0.6/+0.1}	M64x2	290	82	30
KP210H Y(Hdy.)140	225	90	∅71 ^{H10/f8}	120	183	160	40	18	65	80 ^{+0.6/+0.1}	M72x2	290	87	30

**Rod End Nut
∅40~∅63**

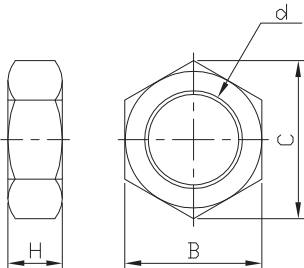

Unit : mm

Part no.	d	B	C	H
KP210H RN(Hdy.)40	M20xP1.5	30	34	12
KP210H RN(Hdy.)50	M24xP1.5	36	41	14
KP210H RN(Hdy.)63	M30xP1.5	41	47	17

※ For rod end nut attached type, longer thread length (dimension A) is required.

**Rod End Nut
∅80~∅160**

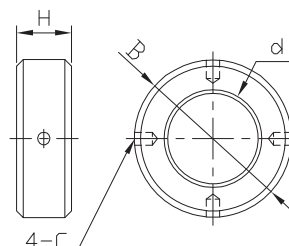

Unit : mm

Part no.	d	B	C	H
KP210H RN(Hdy.)80	M39xP1.5	∅58	∅8	20
KP210H RN(Hdy.)100	M48xP1.5	∅70	∅8	26
KP210H RN(Hdy.)125	M64xP2	∅84	∅8	35
KP210H RN(Hdy.)140	M72xP2	∅108	∅10	38
KP210H RN(Hdy.)160	M80xP2	∅115	∅10	43

Knuckle Joint / Clevis Pin

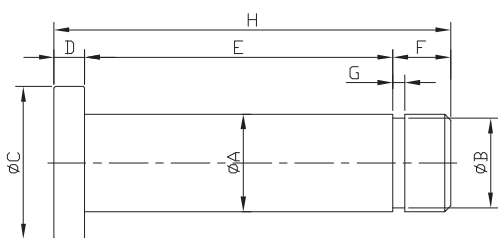

Unit : mm

Part no.		A	B	C	D	E	F	G	H
Clevis Pin		Knuckle Joint Pin							
KP210H CB PIN(Hdy.)40	KP210H Y PIN(Hdy.)40	20	18.5	30	5	64	10	2	79
KP210H CB PIN(Hdy.)50	KP210H Y PIN(Hdy.)50	25	23.9	32	5	72	10	1.5	87
KP210H CB PIN(Hdy.)63	KP210H Y PIN(Hdy.)63	31.5	30	40	5	80.5	9.5	2.5	95
KP210H CB PIN(Hdy.)80	KP210H Y PIN(Hdy.)80	40	37.5	50	5	100.5	9.5	2.5	115
KP210H CB PIN(Hdy.)100	KP210H Y PIN(Hdy.)100	50	46.5	60	5	126.5	9.5	3	141
KP210H CB PIN(Hdy.)125	KP210H Y PIN(Hdy.)125	63	58.5	70	10	161	9	3	180
KP210H CB PIN(Hdy.)140	KP210H Y PIN(Hdy.)140	71	58.5	70	10	161	9	3	180

KPC70/140H series



Features

- Heavy machinery (Mill type)
- Double acting hydraulic cylinder for 70kgf/cm² or 140kgf/cm² with bore sizes from Ø40 to Ø250.
- Heavy-duty type resistant to surge pressure, vibration and impact.
- Various mounting styles. (SD, LA, FA, FB, CA, TC)

Symbol

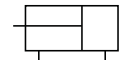

Double Acting / Single Rod

How to Order

KPC70H - SD 40 A - B 300 A B

① ② ③ ④ ⑤ ⑥ ⑦ ⑧ ⑨ ⑩ ⑪ ⑫ ⑬

① Series

KPC70H	Single rod	70kgf/cm ²
KPC140H		140kgf/cm ²

② Seal material

Nil	Nitrile urethane
1	Nitrile rubber
2	Fluoric rubber

③ Mounting style

SD	Standard
LA	Axial angle of foot
FA	Rod side flange
FB	Head side flange
CA	Single clevis
TC	Center trunnion

④ Bore size ⑤ Rod type

Bore size	A	B
40	Ø40	Ø28
50	Ø50	Ø35
63	Ø63	Ø45
80	Ø80	Ø56
100	Ø100	Ø71
125	Ø125	Ø90
140	Ø140	Ø100
160	Ø160	Ø112
180	Ø180	Ø125
200	Ø200	Ø140
224	Ø224	Ø160
250	Ø250	Ø180

⑥ Cushion

N	Without cushion
B	Cushions on both ends
R	Rod side cushion
H	Head side cushion

⑦ Cylinder stroke

All mounting styles accept TC mounting type		TC mounting style	
Bore size	Max. stroke	Bore size	Max. stroke
Ø40~Ø63	0~2000	Ø40~Ø80	101~2000
Ø80~Ø160	51~2000	Ø100, Ø125	151~2000
Ø180~Ø250	101~2000	Ø140~Ø200	201~2000
		Ø224, Ø250	251~2000

* Contact us for longer stroke.

* Check buckling, it varies depending on mounting style.

⑧ Port position

A	Standard
B,C,D	Refer to the figure below

⑨ Cushion valve position

B	Standard
A,C,D	Refer to the figure below

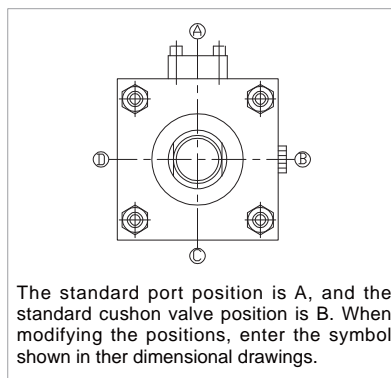

⑩ Bellows

	Material	Max. ambient temperature
Nil	Without bellows	
J	Nylon Tarpaulin	60 °C
K	Neoprene Cloth	110 °C

⑪ Rod end attachment type

Nil	Rod end nut (Standard)
I	Single knuckle joint
Y	Double knuckle joint

⑫ Rod end thread type

Nil	Type 1 (Standard)	
2	Type 2	

* The rod end thread of type 2 is longer than that of type 1 and has a lock nut.

⑬ Port type

Nil	Type X (Standard)	
YF	Type YF	
Z	Type Z	

* The cylinder with type X port will be provided if the customer does not specify the port type.



Specifications

Type		KPC70H	KPC140H	
Bore size		Ø40, Ø50, Ø63, Ø80, Ø100, Ø125, Ø140, Ø160, Ø200, Ø224, Ø250		
Operating pressure		70kgf/cm ² (7.0MPa)	140kgf/cm ² (14.0MPa)	
Max. operating pressure		140kgf/cm ² (14.0MPa)	230kgf/cm ² (23.0MPa)	
Proof pressure		170kgf/cm ² (17.0MPa)	280kgf/cm ² (28.0MPa)	
Min. operating pressure	Ø40~Ø140	3kgf/cm ² (0.3MPa)		
	Ø160~Ø250	5kgf/cm ² (0.5MPa)		
Operating piston speed	Ø40~Ø140	10~500mm/sec		
	Ø160~Ø250	20~500mm/sec		
Ambient & fluid temperature		-10 ~ 80 °C (No freezing)		
Cushion		Metal pressure reducing type		
Working oil		Petroleum-based fluid		
Tolerance of thread		KS class 2		
Tolerance of stroke		≤100mm ^{+0.8} / ₀	≤101~250mm ^{+1.0} / ₀	≤251~630mm ^{+1.25} / ₀
		≤631~1000mm ^{+1.4} / ₀	≤1001~1600mm ^{+1.6} / ₀	≤1601~2000mm ^{+1.8} / ₀
Mounting style		SD, LA, FA, FB, CA, TC		
Accessory	Bellows	J : Nylon Tarpaulin, K : Neoprene Cloth		
	Rod end attachment	Single knuckle joint (I-type), Double knuckle joint (Y-type)		
	Other	Rod end nut		

Hydraulic Cylinder
Reference Data
KP140H
KP210H
KPC70/140H
KPC210H
KTC70HP
KP140HS
KP125/160A
KP35R
KH

* Operating pressure: Max. allowable setting pressure for a relief valve while cylinder is operating.
* Min. operating pressure: Minimum pressure for cylinder installed horizontally and operating without load.

Cushion Length

Unit:mm

Bore size	Ø40 ~ Ø50	Ø63 ~ Ø160	Ø180 ~ Ø224	Ø250
Cushion length	20	25	30	35

* Cushion is not applied to the following type.
A type bore size: Ø40, Ø50, Ø63 rod side
B type bore size: Ø40 rod side

Mass

Unit : kg

Bore size	Rod type	Basic mass (SD)	Mass of mounting					Accessory		Lock nut	Additional mass per each 1mm of stroke
			LA	FA	FB	CA	TC	Single knuckle Joint	Double knuckle Joint		
Ø40	A	10.55	1.29	0.49	1.55	1.35	0.75	0.99	1.14	0.11	0.0103
	B	10.5						1.05	1.08	0.04	0.0086
Ø50	A	13.15	1.46	1.25	2.61	1.99	0.85	1.27	1.81	0.22	0.0146
	B	13.14						1.40	1.63	0.11	0.0116
Ø63	A	20.57	1.90	1.99	4.10	3.29	1.55	2.29	3.63	0.47	0.0209
	B	20.35						2.57	3.23	0.22	0.0162
Ø80	A	34.07	2.85	1.98	5.61	6.00	2.66	4.61	6.21	0.92	0.0332
	B	33.76						5.06	5.71	0.47	0.0264
Ø100	A	57.15	4.33	3.35	9.99	11.16	6.09	8.95	11.73	1.85	0.0524
	B	55.76						10.21	11.43	0.92	0.0406
Ø125	A	96.9	7.58	7.24	18.13	21.33	10.42	18.36	25.70	3.24	0.0832
	B	94.15						16.01	23.64	1.85	0.0644
Ø140	A	126.47	9.18	10.76	25.21	28.52	14.62	27.40	32.88	5.2	0.1087
	B	121.52						22.51	31.08	2.49	0.0865
Ø160	A	163.55	10.46	34.72	35.77	42.12	18.43	39.88	48.48	6.07	0.1305
	B	147.52		37.71				33.76	39.01	3.24	0.1031
Ø180	A	236.58	13.44	44.11	48.91	64.77	26.11	65.06	78.86	10.55	0.1925
	B	212.05		48.27				54.20	72.24	5.2	0.1579
Ø200	A	322.46	19.34	57.84	63.87	77.88	36.88	82.0	94.55	14.57	0.2347
	B	295.01		63.67				68.93	87.11	6.07	0.1912
Ø224	A	412.07	24.17	75.01	88.56	108.49	47.92	114.7	138.05	22.24	0.2893
	B	373.86		82.74				98.66	129.54	10.55	0.2278
Ø250	A	549.29	28.41	103.85	114.40	152.91	66.34	166.9	189.96	32.20	0.3638
	B	487.94		111.27				136.4	175.95	14.57	0.2848

Calculation:

Ex.) KPC70H-FA200A-N300 A B
Basic mass: 322.46
Additional mass: 0.2347
Cylinder stroke: 200mm / FA type: 57.84
322.46+57.84+(0.2347 X 200) = 450.71kg

Structure

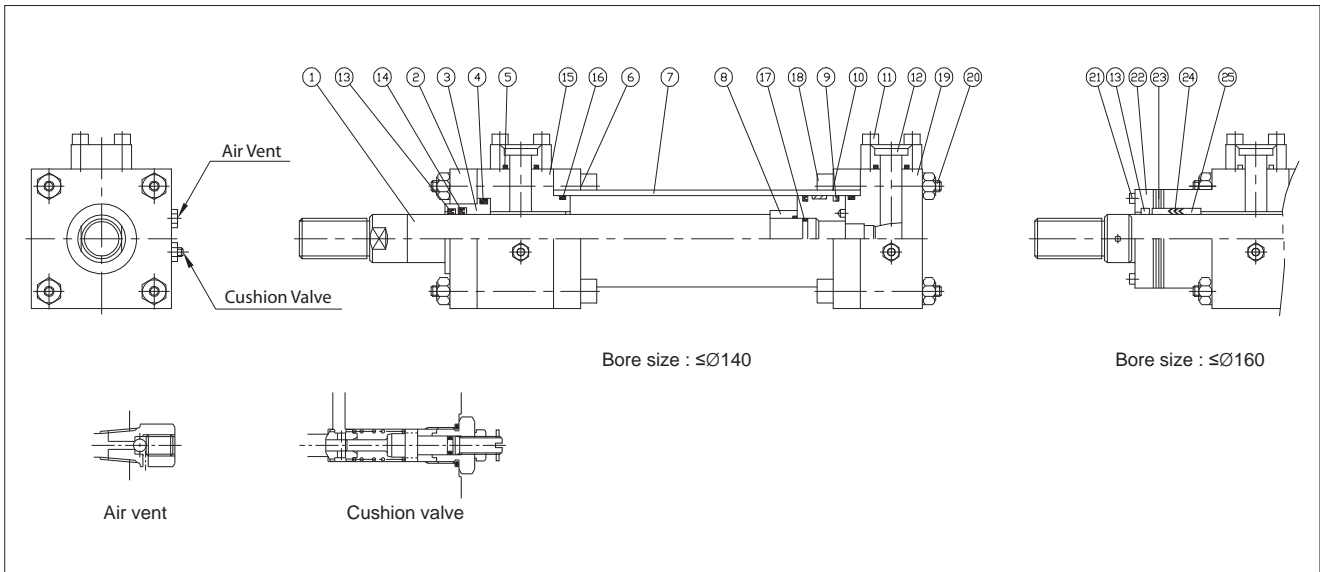

Part List

Part no.	Parts	Material	Quantity
1	Piston Rod	S45C	1
2	Retainer(Bush Cover)	SS41	1
3	Bush	BC3	1
6	Tube Flange	SS41	2
7	Tube	STKM13C	1
8	Cushion Ring	BC6	1
10	Piston	S45C	1
11	Socket Bolt	SCM440	8
12	PT-Flange	SS41	2

Part no.	Parts	Material	Quantity
15	Rod Cover	SS41	1
18	Socket Bolt	SCM440	8
19	Head Cover	SS41	1
20	Hex Nut	S45C	8
21	Socket Bolt	SCM440	8
22	Flange	SS41	1
23	Shin	SS41	2
25	Bush	BC3	2

Packing List

Part no.	4		5	9	13		14		16	17	24	
	O-Ring		O-Ring	P/Packing	Dust Seal		Rod Packing		T/O-Ring	R/O-Ring	V-Packing	
	A type	B type	A/B type	A/Btype	A type	B type	A type	B type	A/Btype	A/Btype	A type	B type
Material	Urethane		Urethane	Urethane	Urethane		Urethane		NBR	NBR	NBR	
Quantity	1		2	2	1		1		2	1	1	
Bore size	1		2	2	1		1		2	1	1	
Ø40	G45	G40	G25	40x30x6	LBI28	LBI22.4	IAI28	ISI22.4	G35	P18	-	-
Ø50	G55	G45	G25	50x40x6	LBI35.5	LBI28	ISI35.5	ISI28	G45	P22A	-	-
Ø63	G65	G55	G25	63x53x6	LBI45	LBI35.5	ISI45	ISI35.5	G58	P29.5	-	-
Ø80	G80	G65	G30	80x65x9	LBI56	LBI45	ISI56	ISI45	G75	G40	-	-
Ø100	G100	G80	G30	100x85x9	LBI71	LBI56	ISI71	ISI56	G95	G50	-	-
Ø125	G120	G100	G35	125x100x9	LBI90	LBI71	ISI90	ISI71	G120	G65	-	-
Ø140	G130	G115	G35	140x125x9	LBI100	LBI80	ISI100	ISI80	G135	G75	-	-
Ø160	-	-	G35	160x140x12	LBI112	LBI90	ISI112	ISI90	G150	G85	Ø112	Ø90
Ø180	-	-	G40	180x160x12	LBI125	LBI100	ISI125	ISI100	G170	G95	Ø125	Ø100
Ø200	-	-	G50	200x180x12	LBI140	LBI112	ISI140	ISI112	G190	G107	Ø140	Ø112
Ø224	-	-	G50	224x204x12	SDR160	LBI125	ISI160	ISI125	G214	G120	Ø160	Ø125
Ø250	-	-	G60	250x230x12	LBI180	LBI140	ISI180	ISI140	G240	G135	Ø180	Ø140

Dimensions-Standard (SD)

Ø40 ~ Ø140

*Cushion is not applied to the following type.
A type bore size: Ø40, Ø50, Ø63 rod side
B type bore size: Ø40 rod side

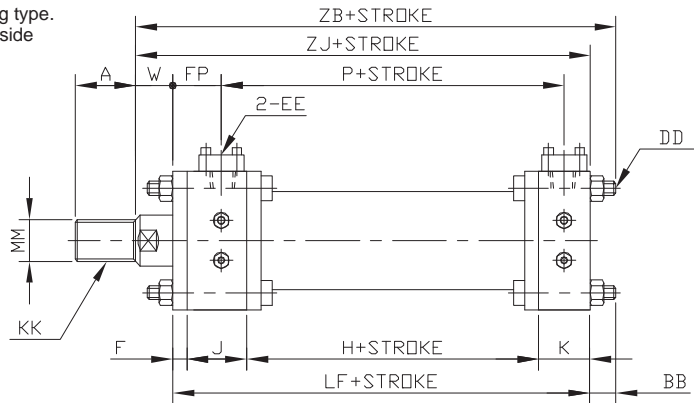
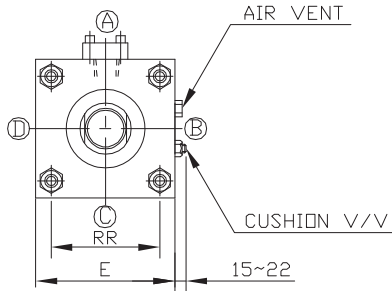

Ø160 ~ Ø250

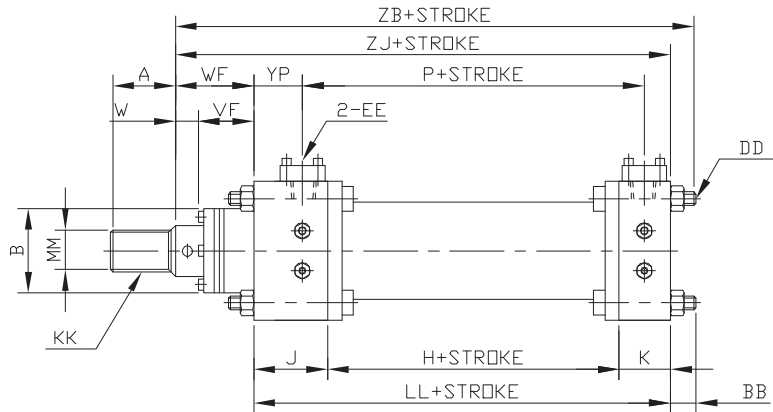
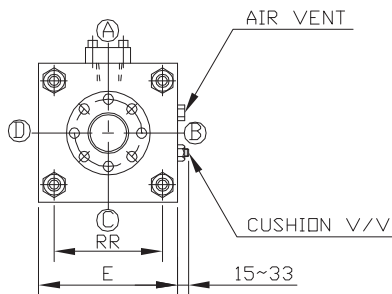

Unit : mm

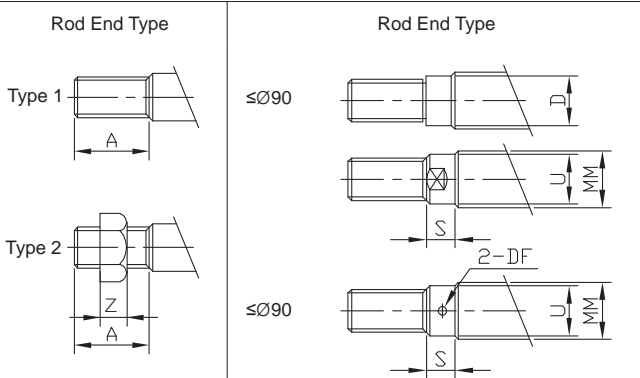

Bore size	A type rod					B type rod				
	D	DF	MM	S	U	D	DF	MM	S	U
Ø40	24	-	Ø28	-	-	19	-	Ø22	-	-
Ø50	30	-	Ø35	-	-	24	-	Ø28	-	-
Ø63	41	-	Ø45	25	Ø44	30	-	Ø35	25	Ø34.5
Ø80	50	-	Ø55	28	Ø55	41	-	Ø45	28	Ø44
Ø100	65	-	Ø70	34	Ø70	50	-	Ø55	34	Ø55
Ø125	85	-	Ø90	39	Ø89	65	-	Ø70	39	Ø70
Ø140	-	Ø12	Ø100	35	Ø99	75	-	Ø80	40	Ø79
Ø160	-	Ø15	Ø112	30	Ø111	85	-	Ø90	30	Ø89
Ø180	-	Ø15	Ø125	35	Ø124	-	Ø12	Ø100	35	Ø99
Ø200	-	Ø15	Ø140	33	Ø139	-	Ø15	Ø112	33	Ø111
Ø224	-	Ø15	Ø160	35	Ø159	-	Ø15	Ø125	35	Ø124
Ø250	-	Ø15	Ø180	35	Ø179	-	Ø15	Ø140	35	Ø139

Unit : mm

Bore size	A type rod				B type rod				BB	DD	E	EE	F	FP	H	J	K	LF	LL	P	RR	VF	W	WF	YP	ZB	ZJ		
	A		KK	Z	A		KK	Z																					
	Typ.1	Typ.2			Typ.1	Typ.2																							
Ø40	35	55	-	M24X1.5	19	30	45	-	M20X1.5	16	11	M10x1.5	□80	SSA15	18	47	64	56	54	192	-	118	□60	-	29	-	-	232	221
Ø50	45	65	-	M30X1.5	24	35	55	-	M24X1.5	19	13	M12x1.75	□90	SSA15	18	47	68	56	54	196	-	122	□68	-	29	-	-	238	225
Ø63	60	85	-	M39X1.5	31	45	65	-	M30X1.5	24	14	M14x2	□110	SSA15	20	61	87	68	54	229	-	141	□80	-	40	-	-	283	269
Ø80	75	105	-	M48X1.5	38	60	85	-	M39X1.5	31	16	M16x2	□127	SSA20	26	70	97	73	58	254	-	155	□98	-	33	-	-	303	287
Ø100	95	140	-	M64X2	51	75	105	-	M48X1.5	38	19	M20x2.5	□154	SSA20	31	87	96	85	58	270	-	154	□120	-	39	-	-	328	309
Ø125	120	175	-	M80X2	64	95	140	-	M64X2	51	22	M24x2	□188	SSA25	36	105	106	103	68	313	-	174	□144	-	44	-	-	379	357
Ø140	140	210	-	M95X2	76	110	160	-	M72X2	58	26	M27x2	□212	SSA25	36	105	116	103	68	323	-	184	□162	-	49	-	-	398	372
Ø160	150	220	Ø191	M100X2	80	120	175	162	M80X2	64	28	M30x2	□238	SSA25	-	-	132	74	72	-	278	204	□184	92	35	127	38	433	405
Ø180	180	265	Ø208	M120X2	96	140	210	172	M95X2	76	30	M33x2	□272	SSA32	-	-	142	84	82	-	308	224	□214	92	40	132	43	470	440
Ø200	195	285	Ø229	M130X2	104	150	220	191	M100X2	80	33	M36x2	□298	SSA40	-	-	152	102	102	-	356	254	□232	102	38	140	51	529	496
Ø224	225	330	Ø253	M150X2	120	180	265	208	M120X2	96	35	M39x2	□328	SSA40	-	-	162	102	102	-	366	264	□256	112	42	154	51	555	520
Ø250	255	375	Ø280	M170X3	136	195	285	229	M130X2	104	38	M42x2	□362	SSA40	-	-	172	111	102	-	385	274	□286	127	48	175	60	598	560

Hydraulic Cylinder

Reference Data

KP140H

KP210H

KPC70/140H

KPC210H

KTC70HP

KP140HS

KP125/160A

KP35R

KH

Dimensions-Axial Angle of Foot (LA)

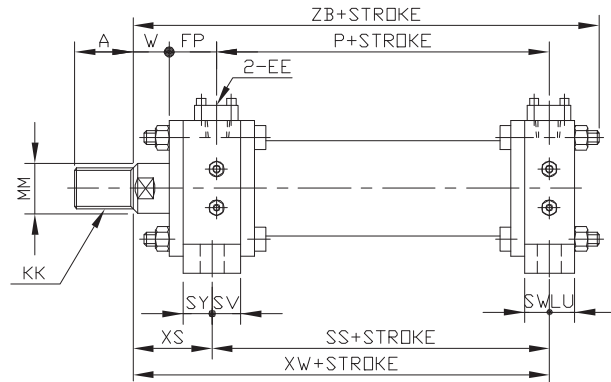
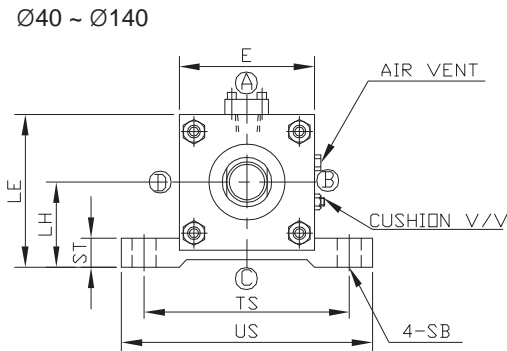

Ø160 ~ Ø250

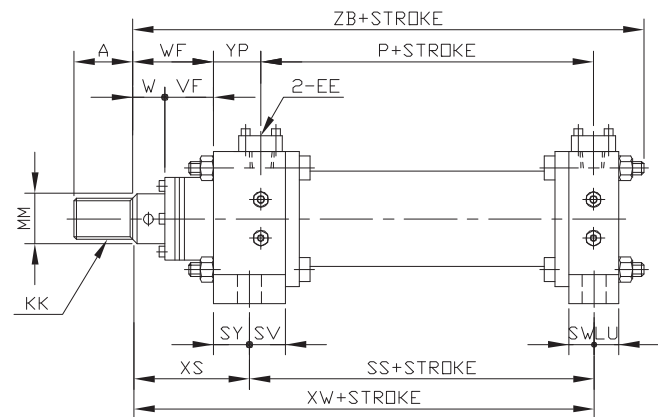
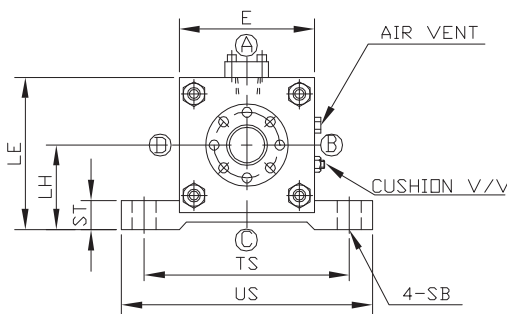

※ Cushion is not applied to the following type.
A type bore size: Ø40, Ø50, Ø63 rod side
B type bore size: Ø40 rod side
※ For not shown dimensions, refer to SD type (standard type).

Unit : mm

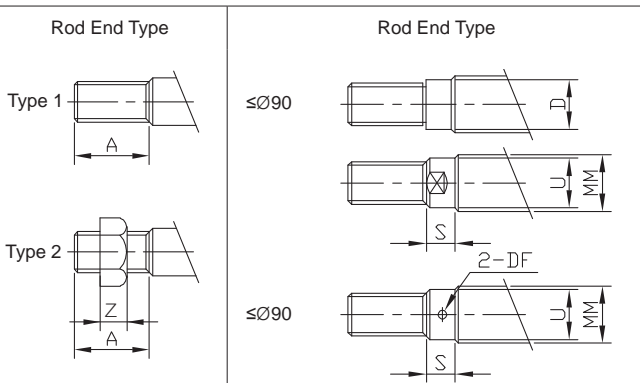

Bore size	A type rod					B type rod				
	D	DF	MM	S	U	D	DF	MM	S	U
Ø40	24	-	Ø28	-	-	19	-	Ø22	-	-
Ø50	30	-	Ø35	-	-	24	-	Ø28	-	-
Ø63	41	-	Ø45	25	Ø44	30	-	Ø35	25	Ø34.5
Ø80	50	-	Ø55	28	Ø55	41	-	Ø45	28	Ø44
Ø100	65	-	Ø70	34	Ø70	50	-	Ø55	34	Ø55
Ø125	85	-	Ø90	39	Ø89	65	-	Ø70	39	Ø70
Ø140	-	Ø12	Ø100	35	Ø99	75	-	Ø80	40	Ø79
Ø160	-	Ø15	Ø112	30	Ø111	85	-	Ø90	30	Ø89
Ø180	-	Ø15	Ø125	35	Ø124	-	Ø12	Ø100	35	Ø99
Ø200	-	Ø15	Ø140	33	Ø139	-	Ø15	Ø112	33	Ø111
Ø224	-	Ø15	Ø160	35	Ø159	-	Ø15	Ø125	35	Ø124
Ø250	-	Ø15	Ø180	35	Ø179	-	Ø15	Ø140	35	Ø139

Unit : mm

Bore size	A type rod			B type rod			E	EE	FP	LE	LH	LU	P	SB	SS	ST	SV	SW	SY	TS	US	VF	W	WF	XS	XW	YP	ZB		
	A		Z	A		Z																								
	Typ.1	Typ.2		Typ.1	Typ.2																									
Ø40	35	55	M24X1.5	19	30	45	M20X1.5	16	□80	SSA15	47	100	60±0.15	26	118	Ø14	120	20	28	28	28	125±0.5	155	-	29	-	75	195	-	232
Ø50	45	65	M30X1.5	24	35	55	M24X1.5	19	□90	SSA15	47	110	65±0.15	30	122	Ø16	120	20	28	24	28	140±0.5	175	-	29	-	75	195	-	238
Ø63	60	85	M39X1.5	31	45	65	M30X1.5	24	□110	SSA15	61	125	70±0.25	24	141	Ø18	150	25	33	30	35	155±0.5	190	-	40	-	95	145	-	283
Ø80	75	105	M48X1.5	38	60	85	M39X1.5	31	□127	SSA20	70	143.5	80±0.25	27	155	Ø20	165	30	37	31	36	180±0.5	220	-	33	-	95	260	-	303
Ø100	95	140	M64X2	51	75	105	M48X1.5	38	□154	SSA20	87	172	95±0.25	29	154	Ø24	165	35	40	29	45	220±0.5	265	-	39	-	115	280	-	328
Ø125	120	175	M80X2	64	95	140	M64X2	51	□188	SSA25	105	209	115±0.25	32	174	Ø30	195	40	53	36	50	275±0.8	330	-	44	-	130	325	-	379
Ø140	140	210	M95X2	76	110	160	M72X2	58	□212	SSA25	105	231	125±0.25	37	184	Ø33	200	45	53	31	50	305±0.8	365	-	49	-	135	335	-	398
Ø160	150	220	M100X2	80	120	175	M80X2	64	□238	SSA25	-	264	145±0.25	34	204	Ø36	206	55	36	38	38	340±0.8	405	92	35	127	165	371	38	433
Ø180	180	265	M120X2	96	140	210	M95X2	76	□272	SSA32	-	296	160±0.25	40	224	Ø39	225	60	41	42	43	375±0.8	445	92	40	132	175	400	43	470
Ø200	195	285	M130X2	104	150	220	M100X2	80	□298	SSA40	-	324	175±0.25	51	254	Ø42	250	65	47	51	55	410±0.8	485	102	38	140	195	445	51	529
Ø224	225	330	M150X2	120	180	265	M120X2	96	□328	SSA40	-	359	195±0.25	50	264	Ø48	265	70	51	52	51	460±0.8	545	112	42	154	205	470	51	555
Ø250	255	375	M170X3	136	195	285	M130X2	104	□362	SSA40	-	396	215±0.25	48	274	Ø52	282	75	56	54	55	500±0.8	590	127	48	175	230	512	60	598

Dimensions-Rod Side Flange (FA)

Ø40 ~ Ø140

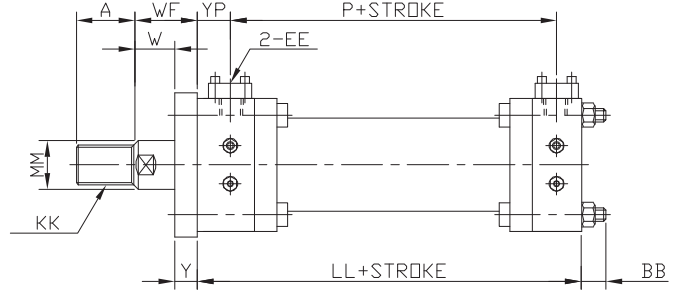
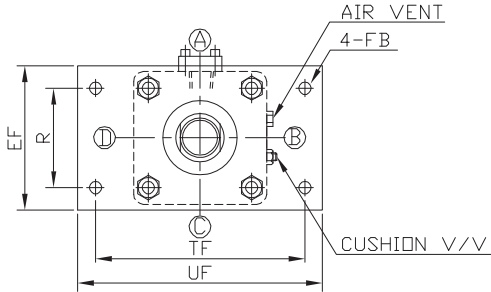

Ø160 ~ Ø250

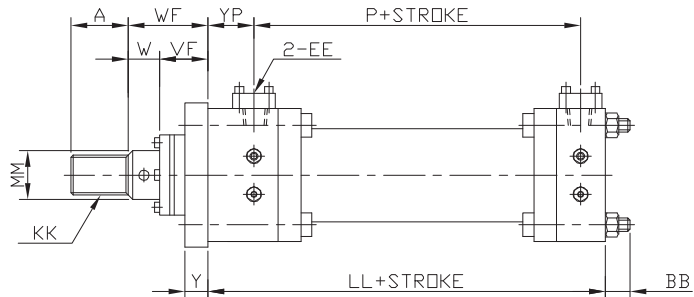
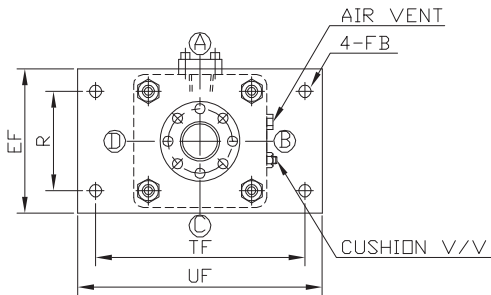

※ Cushion is not applied to the following type.
A type bore size: Ø40, Ø50, Ø63 rod side
B type bore size: Ø40 rod side
※ For not shown dimensions, refer to SD type (standard type).

Unit : mm

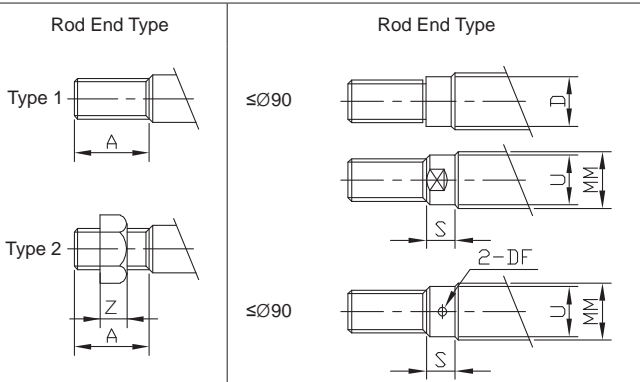

Bore size	A type rod					B type rod				
	D	DF	MM	S	U	D	DF	MM	S	U
Ø40	24	-	Ø28	-	-	19	-	Ø22	-	-
Ø50	30	-	Ø35	-	-	24	-	Ø28	-	-
Ø63	41	-	Ø45	25	Ø44	30	-	Ø35	25	Ø34.5
Ø80	50	-	Ø55	28	Ø55	41	-	Ø45	28	Ø44
Ø100	65	-	Ø70	34	Ø70	50	-	Ø55	34	Ø55
Ø125	85	-	Ø90	39	Ø89	65	-	Ø70	39	Ø70
Ø140	-	Ø12	Ø100	35	Ø99	75	-	Ø80	40	Ø79
Ø160	-	Ø15	Ø112	30	Ø111	85	-	Ø90	30	Ø89
Ø180	-	Ø15	Ø125	35	Ø124	-	Ø12	Ø100	35	Ø99
Ø200	-	Ø15	Ø140	33	Ø139	-	Ø15	Ø112	33	Ø111
Ø224	-	Ø15	Ø160	35	Ø159	-	Ø15	Ø125	35	Ø124
Ø250	-	Ø15	Ø180	35	Ø179	-	Ø15	Ø140	35	Ø139

Unit : mm

Bore size	A type rod				B type rod				BB	EE	EF	FB	LL	P	R	TF	UF	VF	W	WF	Y	YP
	A		KK	Z	A		KK	Z														
	Typ.1	Typ.2			Typ.1	Typ.2																
Ø40	35	55	M24X1.5	19	30	45	M20X1.5	16	11	SSA15	85	Ø14	174	118	55±0.3	125±0.5	155	-	29	-	15	-
Ø50	45	65	M30X1.5	24	35	55	M24X1.5	19	13	SSA15	95	Ø16	178	122	60±0.3	140±0.5	175	-	29	-	20	-
Ø63	60	85	M39X1.5	31	45	65	M30X1.5	24	14	SSA15	110	Ø18	209	141	75±0.5	155±0.5	190	-	40	-	25	-
Ø80	75	105	M48X1.5	38	60	85	M39X1.5	31	16	SSA20	130	Ø20	228	155	90±0.5	180±0.5	220	-	33	-	25	-
Ø100	95	140	M64X2	51	75	105	M48X1.5	38	19	SSA20	160	Ø24	239	154	115±0.5	220±0.5	265	-	39	-	30	-
Ø125	120	175	M80X2	64	95	140	M64X2	51	22	SSA25	200	Ø30	277	174	145±0.5	275±0.8	330	-	44	-	35	-
Ø140	140	210	M95X2	76	110	160	M72X2	58	26	SSA25	220	Ø33	287	184	160±0.5	305±0.8	365	-	49	-	40	-
Ø160	150	220	M100X2	80	120	175	M80X2	64	28	SSA25	330	Ø36	278	204	185±0.5	340±0.8	405	92	35	127	45	38
Ø180	180	265	M120X2	96	140	210	M95X2	76	30	SSA32	340	Ø39	308	224	210±0.5	375±0.8	445	92	40	132	50	43
Ø200	195	285	M130X2	104	150	220	M100X2	80	33	SSA40	380	Ø42	356	254	230±0.5	410±0.8	485	102	38	140	55	51
Ø224	225	330	M150X2	120	180	265	M120X2	96	35	SSA40	430	Ø48	366	264	255±0.8	460±0.8	545	112	42	154	60	51
Ø250	255	375	M170X3	136	195	285	M130X2	104	38	SSA40	465	Ø52	385	274	285±0.8	500±0.8	590	127	48	175	65	60

Dimensions-Head Side Flange (FB)

Ø40 ~ Ø140

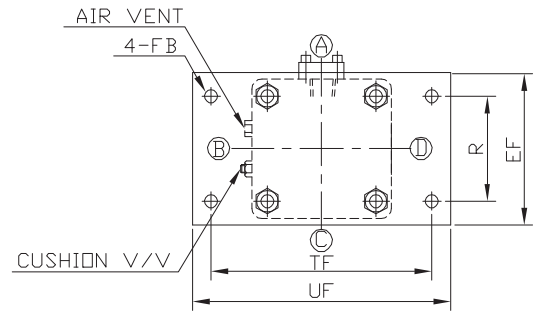
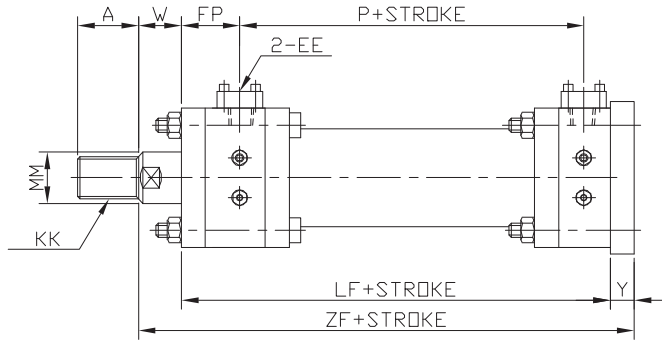

Ø160 ~ Ø250

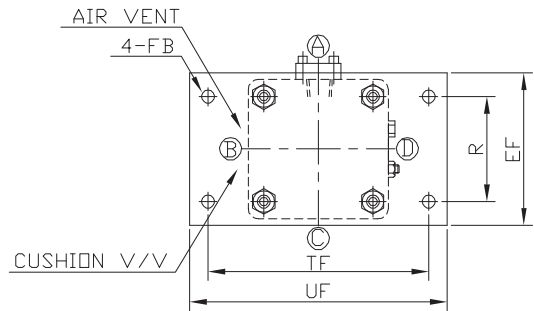
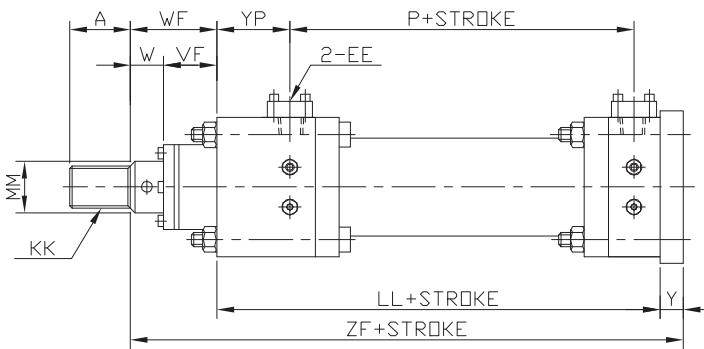

- ※ Cushion is not applied to the following type.
A type bore size: Ø40, Ø50, Ø63 rod side
B type bore size: Ø40 rod side
- ※ For not shown dimensions, refer to SD type (standard type).

Unit : mm

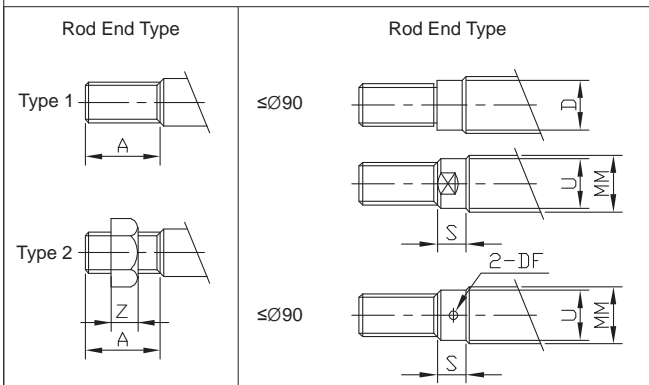

Bore size	A type rod					B type rod				
	D	DF	MM	S	U	D	DF	MM	S	U
Ø40	24	-	Ø28	-	-	19	-	Ø22	-	-
Ø50	30	-	Ø35	-	-	24	-	Ø28	-	-
Ø63	41	-	Ø45	25	Ø44	30	-	Ø35	25	Ø34.5
Ø80	50	-	Ø55	28	Ø55	41	-	Ø45	28	Ø44
Ø100	65	-	Ø70	34	Ø70	50	-	Ø55	34	Ø55
Ø125	85	-	Ø90	39	Ø89	65	-	Ø70	39	Ø70
Ø140	-	Ø12	Ø100	35	Ø99	75	-	Ø80	40	Ø79
Ø160	-	Ø15	Ø112	30	Ø111	85	-	Ø90	30	Ø89
Ø180	-	Ø15	Ø125	35	Ø124	-	Ø12	Ø100	35	Ø99
Ø200	-	Ø15	Ø140	33	Ø139	-	Ø15	Ø112	33	Ø111
Ø224	-	Ø15	Ø160	35	Ø159	-	Ø15	Ø125	35	Ø124
Ø250	-	Ø15	Ø180	35	Ø179	-	Ø15	Ø140	35	Ø139

Unit : mm

Bore size	A type rod			B type rod			EE	EF	FB	FP	LF	LL	P	R	TF	UF	VF	W	WF	Y	YP	ZF	
	A		KK	A		KK																	
	Typ.1	Typ.2		Typ.1	Typ.2																		
Ø40	35	55	M24X1.5	19	30	45	SSA15	85	Ø14	47	192	-	118	55±0.3	125±0.5	155	-	29	-	15	-	233	
Ø50	45	65	M30X1.5	24	35	55	SSA15	95	Ø16	47	196	-	122	60±0.3	140±0.5	175	-	29	-	20	-	243	
Ø63	60	85	M39X1.5	31	45	65	SSA15	110	Ø18	61	229	-	141	75±0.5	155±0.5	190	-	40	-	25	-	299	
Ø80	75	105	M48X1.5	38	60	85	SSA20	130	Ø20	70	254	-	155	90±0.5	180±0.5	220	-	33	-	25	-	313	
Ø100	95	140	M64X2	51	75	105	SSA20	160	Ø24	87	270	-	154	115±0.5	220±0.5	265	-	39	-	30	-	399	
Ø125	120	175	M80X2	64	95	140	SSA25	200	Ø30	105	313	-	174	145±0.5	275±0.8	330	-	44	-	35	-	392	
Ø140	140	210	M95X2	76	110	160	SSA25	220	Ø33	105	323	-	184	160±0.5	305±0.8	365	-	49	-	40	-	412	
Ø160	150	220	M100X2	80	120	175	M80X2	64	SSA25	330	Ø36	-	278	204	185±0.5	340±0.8	405	92	35	127	45	38	456
Ø180	180	265	M120X2	96	140	210	M95X2	76	SSA32	340	Ø39	-	308	224	210±0.5	375±0.8	445	92	40	132	50	43	496
Ø200	195	285	M130X2	104	150	220	M100X2	80	SSA40	380	Ø42	-	356	254	230±0.5	410±0.8	485	102	38	140	55	51	555
Ø224	225	330	M150X2	120	180	265	M120X2	96	SSA40	430	Ø48	-	366	264	255±0.8	460±0.8	545	112	42	154	60	51	584
Ø250	255	375	M170X3	136	195	285	M130X2	104	SSA40	465	Ø52	-	385	274	285±0.8	500±0.8	590	127	48	175	65	60	638

Dimensions-Single Clevis (CA)

Ø40 ~ Ø140

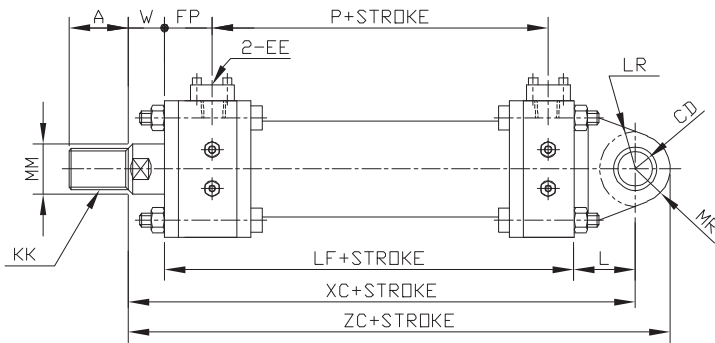

Ø160 ~ Ø250

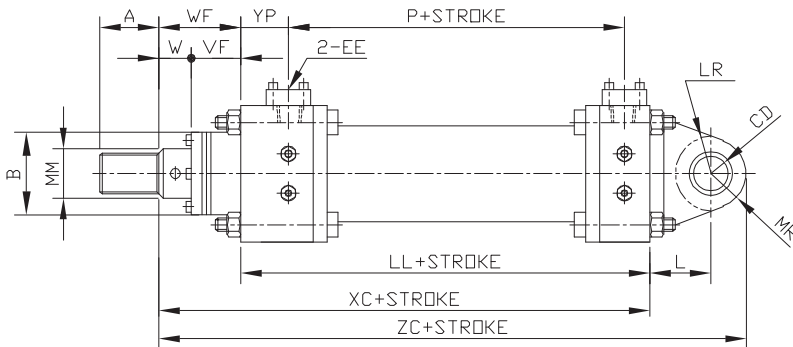

※ Cushion is not applied to the following type.
A type bore size: Ø40, Ø50, Ø63 rod side
B type bore size: Ø40 rod side
※ For not shown dimensions, refer to SD type (standard type).

Unit : mm

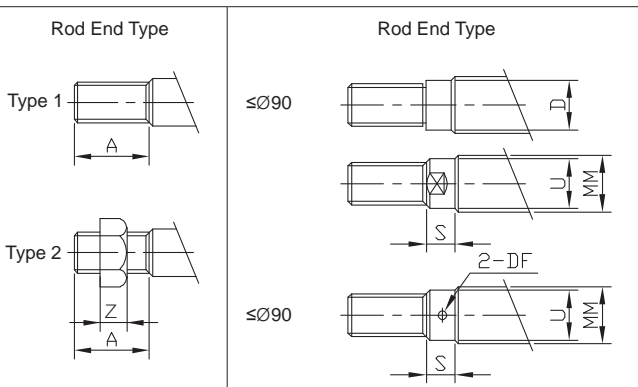

Bore size	A type rod					B type rod				
	D	DF	MM	S	U	D	DF	MM	S	U
Ø40	24	-	Ø28	-	-	19	-	Ø22	-	-
Ø50	30	-	Ø35	-	-	24	-	Ø28	-	-
Ø63	41	-	Ø45	25	Ø44	30	-	Ø35	25	Ø34.5
Ø80	50	-	Ø55	28	Ø55	41	-	Ø45	28	Ø44
Ø100	65	-	Ø70	34	Ø70	50	-	Ø55	34	Ø55
Ø125	85	-	Ø90	39	Ø89	65	-	Ø70	39	Ø70
Ø140	-	Ø12	Ø100	35	Ø99	75	-	Ø80	40	Ø79
Ø160	-	Ø15	Ø112	30	Ø111	85	-	Ø90	30	Ø89
Ø180	-	Ø15	Ø125	35	Ø124	-	Ø12	Ø100	35	Ø99
Ø200	-	Ø15	Ø140	33	Ø139	-	Ø15	Ø112	33	Ø111
Ø224	-	Ø15	Ø160	35	Ø159	-	Ø15	Ø125	35	Ø124
Ø250	-	Ø15	Ø180	35	Ø179	-	Ø15	Ø140	35	Ø139

Unit : mm

Bore size	A type rod					B type rod					CD	E	EE	EW	FP	L	LF	LL	LR	MR	P	VF	W	WF	XC	YP	ZC
	A		B	KK	Z	A		B	KK	Z																	
	Typ.1	Typ.2				Typ.1	Typ.2																				
Ø40	35	55	-	M24X1.5	19	30	45	-	M20X1.5	16	Ø20 ^{H10}	□80	SSA15	31.5 ^{-0.1/-0.4}	47	56	192	-	R30	R24	118	-	29	-	277	-	301
Ø50	45	65	-	M30X1.5	24	35	55	-	M24X1.5	19	Ø25 ^{H10}	□90	SSA15	35.5 ^{-0.1/-0.4}	47	66	196	-	R40	R30	122	-	29	-	291	-	321
Ø63	60	85	-	M39X1.5	31	45	65	-	M30X1.5	24	Ø31.5 ^{H10}	□110	SSA15	40 ^{-0.1/-0.4}	61	72	229	-	R43	R38	141	-	40	-	341	-	379
Ø80	75	105	-	M48X1.5	38	60	85	-	M39X1.5	31	Ø40 ^{H10}	□127	SSA20	50 ^{-0.1/-0.4}	70	86	254	-	R50	R48	155	-	33	-	373	-	421
Ø100	95	140	-	M64X2	51	75	105	-	M48X1.5	38	Ø50 ^{H10}	□154	SSA20	63 ^{-0.1/-0.4}	87	105	270	-	R65	R60	154	-	39	-	414	-	474
Ø125	120	175	-	M80X2	64	95	140	-	M64X2	51	Ø63 ^{H10}	□188	SSA25	80 ^{-0.1/-0.6}	105	129	313	-	R82	R75	174	-	44	-	486	-	561
Ø140	140	210	-	M95X2	76	110	160	-	M72X2	58	Ø71 ^{H10}	□212	SSA25	80 ^{-0.1/-0.6}	105	147	323	-	R93	R85	184	-	49	-	519	-	604
Ø160	150	220	Ø191	M100X2	80	120	175	Ø162	M80X2	64	Ø80 ^{H10}	□238	SSA25	100 ^{-0.1/-0.6}	-	162	-	278	R105	R96	204	92	35	127	567	38	663
Ø180	180	265	Ø208	M120X2	96	140	210	Ø172	M95X2	76	Ø90 ^{H10}	□272	SSA32	125 ^{-0.1/-0.6}	-	183	-	308	R120	R108	224	92	40	132	623	43	731
Ø200	195	285	Ø229	M130X2	104	150	220	Ø191	M100X2	80	Ø100 ^{H10}	□298	SSA40	125 ^{-0.1/-0.6}	-	189	-	356	R125	R120	254	102	38	140	685	51	805
Ø224	225	330	Ø253	M150X2	120	180	265	Ø208	M120X2	96	Ø112 ^{H10}	□328	SSA40	140 ^{-0.1/-0.6}	-	214	-	366	R145	R135	264	112	42	154	734	51	869
Ø250	255	375	Ø280	M170X3	136	195	285	Ø229	M130X2	104	Ø125 ^{H10}	□362	SSA40	160 ^{-0.1/-0.6}	-	240	-	385	R160	R150	274	127	48	175	800	60	950

Dimensions-Center Trunnion (TC)

Ø40 ~ Ø140

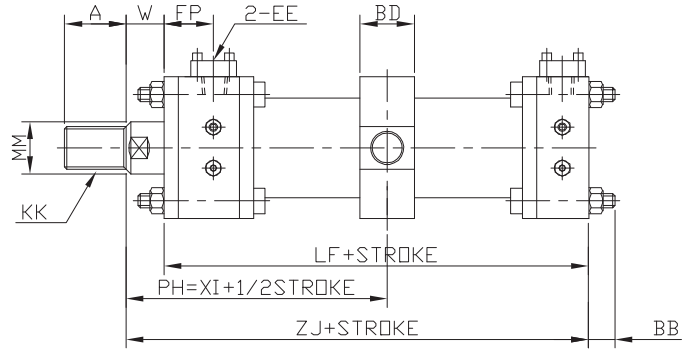
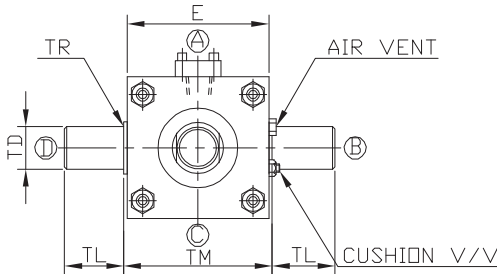

Ø160 ~ Ø250

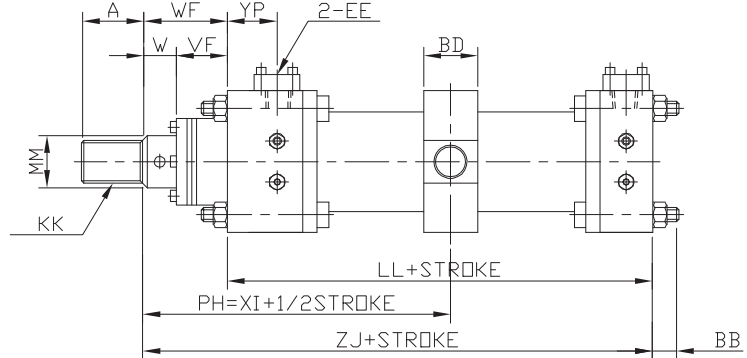
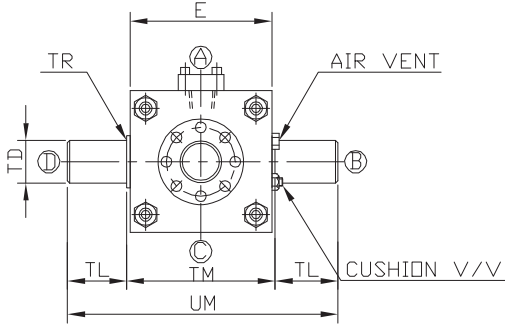

- ※ Cushion is not applied to the following type.
A type bore size: Ø40, Ø50, Ø63 rod side
B type bore size: Ø40 rod side
- ※ For not shown dimensions, refer to SD type (standard type).

Unit : mm

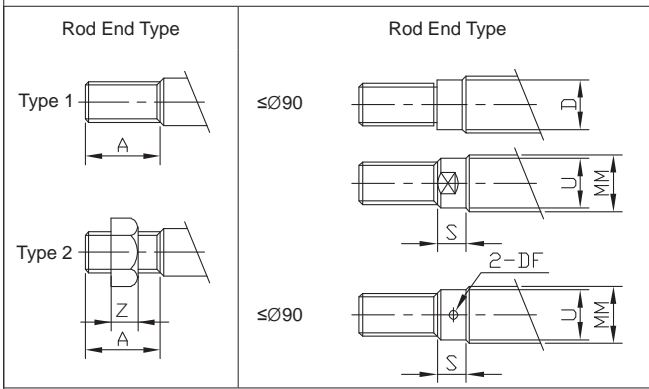

Bore size	A type rod					B type rod				
	D	DF	MM	S	U	D	DF	MM	S	U
Ø40	24	-	Ø28	-	-	19	-	Ø22	-	-
Ø50	30	-	Ø35	-	-	24	-	Ø28	-	-
Ø63	41	-	Ø45	25	Ø44	30	-	Ø35	25	Ø34.5
Ø80	50	-	Ø55	28	Ø55	41	-	Ø45	28	Ø44
Ø100	65	-	Ø70	34	Ø70	50	-	Ø55	34	Ø55
Ø125	85	-	Ø90	39	Ø89	65	-	Ø70	39	Ø70
Ø140	-	Ø12	Ø100	35	Ø99	75	-	Ø80	40	Ø79
Ø160	-	Ø15	Ø112	30	Ø111	85	-	Ø90	30	Ø89
Ø180	-	Ø15	Ø125	35	Ø124	-	Ø12	Ø100	35	Ø99
Ø200	-	Ø15	Ø140	33	Ø139	-	Ø15	Ø112	33	Ø111
Ø224	-	Ø15	Ø160	35	Ø159	-	Ø15	Ø125	35	Ø124
Ø250	-	Ø15	Ø180	35	Ø179	-	Ø15	Ø140	35	Ø139

Unit : mm

Bore size	A type rod				B type rod				BB	BD	E	EE	FP	LF	LL	Min. PH	TD	TL	TM	TR	UM	VF	W	WF	XI	YP	ZJ
	A Typ.1	A Typ.2	KK	Z	A Typ.1	A Typ.2	KK	Z																			
Ø40	35	55	M24X1.5	19	30	45	M20X1.5	16	11	33	□80	SSA15	47	192	-	166	Ø25 ^{±0.08}	25	90 ^{-0.1/-0.05}	R2.5	140	-	29	-	135	-	221
Ø50	45	65	M30X1.5	24	35	55	M24X1.5	19	13	33	□90	SSA15	47	196	-	169	Ø25 ^{±0.08}	25	100 ^{-0.1/-0.05}	R2.5	150	-	29	-	137	-	225
Ø63	60	85	M39X1.5	31	45	65	M30X1.5	24	14	43	□110	SSA15	61	229	-	202	Ø31.5 ^{±0.08}	31.5	115 ^{-0.1/-0.05}	R2.5	178	-	40	-	171.5	-	269
Ø80	75	105	M48X1.5	38	60	85	M39X1.5	31	16	53	□127	SSA20	70	254	-	227	Ø40 ^{±0.08}	40	135 ^{-0.1/-0.05}	R3.0	215	-	33	-	180.5	-	287
Ø100	95	140	M64X2	51	75	105	M48X1.5	38	19	63	□154	SSA20	87	270	-	260	Ø50 ^{±0.08}	50	165 ^{-0.1/-0.05}	R3.0	265	-	39	-	203	-	309
Ø125	120	175	M80X2	64	95	140	M64X2	51	22	78	□188	SSA25	105	313	-	300	Ø63 ^{±0.08}	63	205 ^{-0.1/-0.05}	R4.0	331	-	44	-	236	-	357
Ø140	140	210	M95X2	76	110	160	M72X2	58	26	88	□212	SSA25	105	323	-	315	Ø71 ^{±0.08}	71	225 ^{-0.1/-0.05}	R4.0	367	-	49	-	246	-	372
Ø160	150	220	M100X2	80	120	175	M80X2	64	28	98	□238	SSA25	-	-	278	338	Ø80 ^{±0.08}	80	255 ^{-0.1/-0.05}	R4.0	415	92	35	127	267	38	405
Ø180	180	265	M120X2	96	140	210	M95X2	76	30	108	□272	SSA32	-	-	308	363	Ø90 ^{±0.08}	90	285 ^{-0.1/-0.08}	R5.0	465	92	40	132	287	43	440
Ø200	195	285	M130X2	104	150	220	M100X2	80	33	118	□298	SSA40	-	-	356	404	Ø100 ^{±0.08}	100	310 ^{-0.1/-0.08}	R5.0	510	102	38	140	318	51	496
Ø224	225	330	M150X2	120	180	265	M120X2	96	35	137	□328	SSA40	-	-	366	433	Ø112 ^{±0.08}	112	350 ^{-0.1/-0.08}	R5.0	574	112	42	154	337	51	520
Ø250	255	375	M170X3	136	195	285	M130X2	104	38	147	□362	SSA40	-	-	385	478	Ø125 ^{±0.08}	125	385 ^{-0.1/-0.08}	R5.0	636	127	48	175	372	60	560

Dimensions-Bellows Attached Type (J, K)

Ø40 ~ Ø140

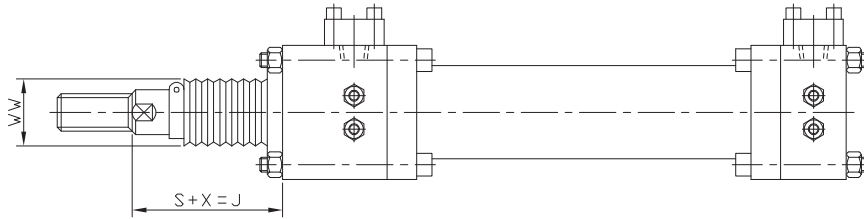

Ø160 ~ Ø250

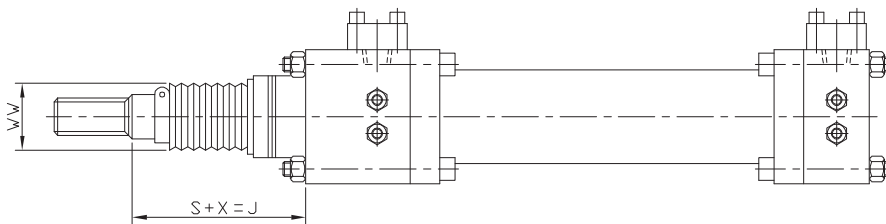

Type	J	K
Material	Nylon Tarpaulin	Neoprene Cloth
Temperature	60°C	110°C

Bore size	Ø40	Ø50	Ø63	Ø80	Ø100	Ø125	Ø140	Ø160	Ø180	Ø200	Ø224	Ø250	
WW	Rod A	Ø63	Ø71	Ø80	Ø100	Ø125	Ø140	Ø160	Ø180	Ø180	Ø200	Ø220	Ø240
	Rod B	Ø50	Ø63	Ø71	Ø80	Ø100	Ø125	Ø125	Ø140	Ø160	Ø180	Ø180	Ø200
X	42	57	60	54	64	64	69	60	80	78	82	78	
S	1/3.5 x Stroke		1/4 x Stroke			1/5 x Stroke				1/6 x Stroke			

- ※ For not shown dimensions, refer to SD type (standard type).
- ※ When calculating with decimals, please round up.
- ※ SUS band is mounted at bellows at delivery.

Hydraulic Cylinder

Reference Data

KP140H

KP210H

KPC70/140H

KPC210H

KTC70HP

KP140HS

KP125/160A

KP35R

KH

Dimensions-Accessory

Unit : mm

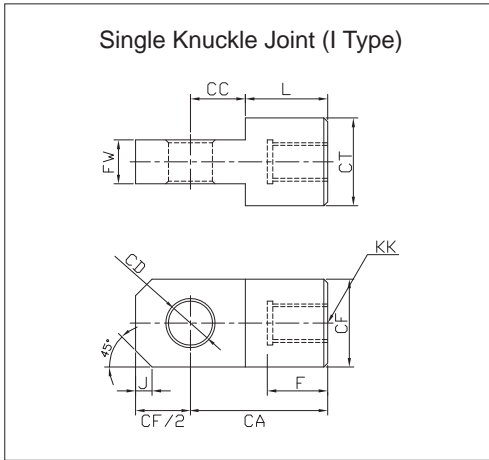

Bore size	CA	CC	CD	CF	CT	CW	F		FW	J	KK		L
							Rod A	Rod B			Rod A	Rod B	
Ø40	80	30	Ø20H10	50	40	16	40	35	31.5 ^{-0.4} _{-0.1}	8	M24X1.5	M20X1.5	50
Ø50	95	35	Ø25H10	60	50	17.5	50	40	35.5 ^{-0.4} _{-0.1}	15	M30X1.5	M24X1.5	60
Ø63	115	40	Ø31.5H10	70	60	20	65	50	40 ^{-0.4} _{-0.1}	15	M39X1.5	M30X1.5	75
Ø80	140	50	Ø40H10	90	70	25	80	65	50 ^{-0.4} _{-0.1}	20	M48X1.5	M39X1.5	90
Ø100	180	65	Ø50H10	110	90	30	100	80	63 ^{-0.4} _{-0.1}	25	M64X2	M48X1.5	115
Ø125	220	80	Ø63H10	140	110	40	125	100	80 ^{-0.1} _{-0.6}	30	M72X2	M64X2	140
Ø140	255	90	Ø71H10	160	130	40	145	115	80 ^{-0.1} _{-0.6}	30	M80X2	M72X2	165
Ø160	275	100	Ø80H10	180	140	50	155	125	100 ^{-0.1} _{-0.6}	40	M95X2	M80X2	175
Ø180	325	115	Ø90H10	210	170	62.5	185	145	125 ^{-0.1} _{-0.6}	40	M100X2	M95X2	210
Ø200	355	125	Ø100H10	230	190	62.5	200	155	125 ^{-0.1} _{-0.6}	40	M120X2	M100X2	230
Ø224	405	140	Ø112H10	250	220	70	230	185	140 ^{-0.1} _{-0.6}	50	M130X2	M120X2	265
Ø250	455	160	Ø125H10	280	250	80	260	200	160 ^{-0.1} _{-0.6}	60	M170X2	M130X2	295

Unit : mm

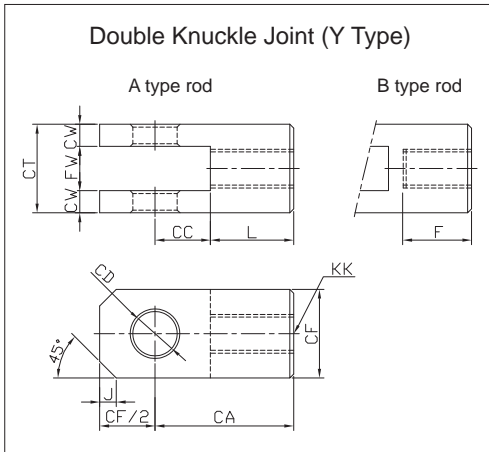

Bore size	CA	CC	CD	CF	CT	CW	F	FW	J	KK		L
										Rod A	Rod B	
Ø40	65	30	Ø20H10	50	70	16	35	38 ^{+1.0} _{+0.1}	8	M24X1.5	M20X1.5	35
Ø50	80	35	Ø25H10	60	75	17.5	40	40 ^{+1.0} _{+0.1}	15	M30X1.5	M24X1.5	45
Ø63	100	40	Ø31.5H10	70	85	20	50	45 ^{+1.0} _{+0.1}	15	M39X1.5	M30X1.5	60
Ø80	125	50	Ø40H10	80	105	25	65	55 ^{+2.0} _{+0.1}	15	M48X1.5	M39X1.5	75
Ø100	160	65	Ø50H10	100	130	30	80	70 ^{+2.0} _{+0.1}	20	M64X2	M48X1.5	95
Ø125	200	80	Ø63H10	130	170	40	100	90 ^{+2.0} _{+0.1}	25	M72X2	M64X2	120
Ø140	230	90	Ø71H10	150	170	40	115	90 ^{+2.0} _{+0.1}	30	M80X2	M72X2	140
Ø160	250	100	Ø80H10	160	210	50	125	110 ^{+2.0} _{+0.1}	30	M95X2	M80X2	150
Ø180	295	115	Ø90H10	180	260	62.5	145	135 ^{+3.0} _{+0.1}	40	M100X2	M95X2	180
Ø200	320	125	Ø100H10	200	260	62.5	155	135 ^{+3.0} _{+0.1}	40	M120X2	M100X2	195
Ø224	365	140	Ø112H10	230	290	70	185	150 ^{+3.0} _{+0.1}	50	M130X2	M120X2	225
Ø250	415	160	Ø125H10	250	330	80	200	170 ^{+4.0} _{+0.1}	60	M170X2	M130X2	255

Unit : mm

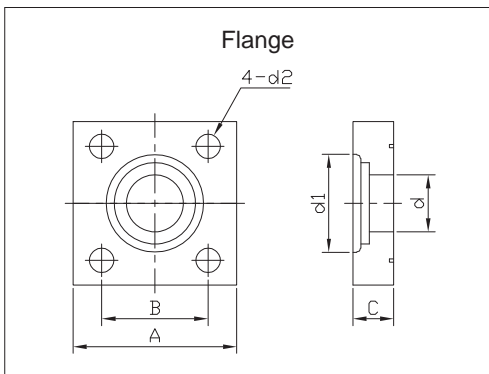

Bore size	Ø40	Ø50	Ø63	Ø80	Ø100	Ø125	Ø140	Ø160	Ø180	Ø200	Ø224	Ø250
JIS Symbol	SSA 15		SSA 20		SSA 25		SSA 32		SSA 40		SSA 50	
Port size	Rc(PT)1/2		Rc(PT)3/4		Rc(PT)1		Rc(PT)1 1/4		Rc(PT)1 1/2		Rc(PT) 2	
A	54		58		68		76		92		106	
B	36		40		48		56		65		73	
C	22		22		28		28		36		36	
d	Ø16		Ø20		Ø25		Ø31.5		Ø37.5		Ø47.5	
d1	Ø22.2 ^{+0.2} ₀		Ø27.7 ^{+0.2} ₀		Ø34.5 ^{+0.3} ₀		Ø43.2 ^{+0.3} ₀		Ø49.1 ^{+0.3} ₀		Ø61.1 ^{+0.3} ₀	
d2	Ø11		Ø11		Ø13		Ø13		Ø18		Ø18	
Bolt	M10		M10		M12		M12		M16		M16	
O-Ring	G25		G30		G35		G40		G50		G60	

Unit : mm

Unit : mm

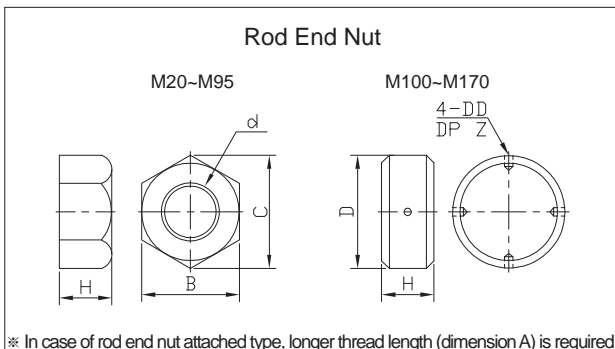

* In case of rod end nut attached type, longer thread length (dimension A) is required.

Symbol	H	B	C
M20xP1.5	16	30 ⁰ _{-0.8}	34.6
M24xP1.5	19	36 ⁰ _{-1.0}	41.6
M30xP1.5	24	46 ⁰ _{-1.0}	53.1
M39xP1.5	31	60 ⁰ _{-1.2}	69.3
M48xP1.5	38	75 ⁰ _{-1.2}	86.5
M64xP2	51	95 ⁰ _{-1.4}	110
M72xP2	58	105 ⁰ _{-1.4}	121
M80xP2	64	115 ⁰ _{-1.4}	133
M95xP2	76	135 ⁰ _{-1.6}	156

Symbol	H	D	DD	Z
M100xP2	80	Ø150	Ø15	18
M120xP2	96	Ø180	Ø15	18
M130xP2	104	Ø200	Ø20	25
M150xP2	120	Ø230	Ø20	25
M170xP3	136	Ø260	Ø20	25

KPC210H series



Features

- High-pressure heavy machinery (Mill type)
- Double acting hydraulic cylinder for 210kgf/cm² with bore sizes from Ø40 to Ø250.
- Heavy-duty type resistant to surge pressure, vibration and impact.
- Various mounting styles. (LA, FA, FB, CA, TC)

Symbol

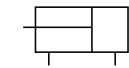

Double Acting / Single Rod

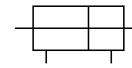

Double Acting / Double Rod

How to Order

KPC210H - **LA** 40 **B** - B 300 A B F

① ② ③ ④ ⑤ ⑥ ⑦ ⑧ ⑨ ⑩ ⑪

① Series

KPC210H	Single rod	210kgf/cm ²
KPC210HW	Double rod	

② Seal material

Nil	Nitrile Urethane (Standard)
1	Nitrile rubber
2	Fluoric rubber

③ Mounting style

LA	Axial angle of foot
FA	Rod side flange
FB	Head side flange
CA	Single clevis
TC	Center trunnion

④ Bore size

40	Ø40
50	Ø50
63	Ø63
80	Ø80
100	Ø100
125	Ø125
140	Ø140
160	Ø160
180	Ø180
200	Ø200
250	Ø250

⑤ Cushion

N	Without cushion
B	Cushions on both ends
R	Rod side cushion
H	Head side cushion

⑥ Cylinder stroke

Bore size	Max. stroke
Ø40, Ø50	1200
Ø63, Ø80	1600
Ø100~Ø250	2000

※ Check buckling, it varies depending on mounting style.
※ Contact us for longer stroke.

⑦ Port position

A	Standard
B,C,D,E,F	Refer to the figure below

⑧ Cushion valve position

B	Standard
A,C,D,E,F	Refer to the figure below

⑨ Check valve position

F	Standard
A,B,C,D,E	Refer to the figure below

⑩ Bellows

	Material	Max. ambient temperature
Nil	Without bellows	
J	Nylon Tarpaulin	60℃
K	Neoprene Cloth	110℃

⑪ Accessory

Nil	None
I	Single knuckle joint

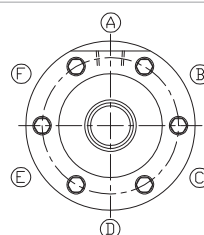

The standard port position is A, check valve position is F and the standard cushion valve position is B. When modifying the positions, enter the symbol shown in their dimensional drawings.



Specifications

Model	KPC210H		
Bore size	Ø40, Ø50, Ø63, Ø80, Ø100, Ø125, Ø140, Ø160, Ø180, Ø200, Ø250		
Operating pressure	210kgf/cm ² (21.0MPa)		
Proof pressure	315kgf/cm ² (31.5MPa)		
Min. operating pressure	12~18kgf/cm ² (1.2~1.8MPa)		
Operating piston speed	10~300mm/sec		
Ambient & fluid temperature	-10~80℃ (Use Viton seal when temperature is over 100℃)		
Working oil	Petroleum-based fluid		
Tolerance of thread	KS class 2		
Tolerance of stroke	≤100mm $\begin{matrix} +0.8 \\ 0 \end{matrix}$,	≤101~250mm $\begin{matrix} +1.0 \\ 0 \end{matrix}$,	≤251~650mm $\begin{matrix} +1.25 \\ 0 \end{matrix}$
	≤651~1000mm $\begin{matrix} +1.4 \\ 0 \end{matrix}$,	≤1001~1500mm $\begin{matrix} +1.6 \\ 0 \end{matrix}$,	≤1501~2000mm $\begin{matrix} +1.8 \\ 0 \end{matrix}$
Accessory	Bellows	J : Nylon Tarpaulin, K : Neoprene Cloth	
	Rod end attachment	Single knuckle joint (I-type)	

* Operating pressure: Max. allowable setting pressure for a relief valve while cylinder is operating.

* Min. operating pressure: Minimum pressure for a cylinder installed horizontally and operating without load.

Cushion Length

Unit : mm

Bore size	Ø40 ~ Ø63	Ø80~Ø160	Ø180~Ø200	Ø250
Cushion length	20	25	30	35

Structure

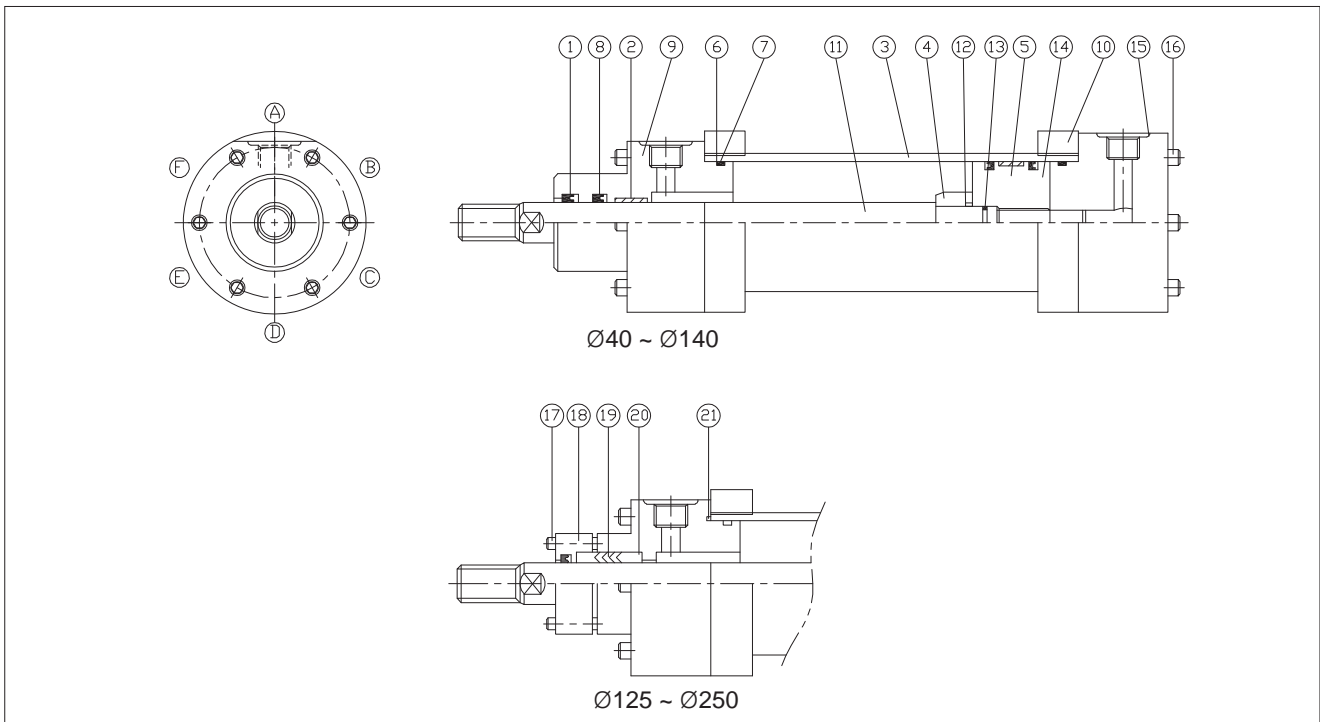

Hydraulic Cylinder
Reference Data
KP140H
KP210H
KPC70/140H
KPC210H
KTC70HP
KP140HS
KP125/160A
KP35R
KH

Part List

Part no.	Parts	Material	Quantity
2	Wear Ring	Phenol	1
3	Tube	STKM13C	1
4	Cushion Ring	BC3	1
9	Rod Cover	S45C & SS41	1
10	Tube Flange	S45C & SS41	2
11	Piston Rod	S45C	1

Part no.	Parts	Material	Quantity
14	Piston	SC45C(FCD40)	1
15	Head Cover	S45C & SS41	1
16	Socket Bolt	SCM440	12
17	Socket Bolt	SCM440	6
18	Retainer	SS41	1
20	Bush	BC3	1

Packing List

Part no.	1	5	6	7	8	12	13	19	21
Parts	Dust Seal	P/Packing	T/O-Ring	B.U.R	R/Packing	O-Ring	R/O-Ring	V-Packing	O-Ring
Material	Urethane	NBR	NBR	Teflon	Urethane	NBR	NBR	NBR, Fabric	NBR
Quantity	1	1 Set	2	2	1	1	1	5	1
Bore size									
Ø40	LBI 20	KDAS 040-030	G35	For G35	ISI 20	P16	P12	-	-
Ø50	LBI 28	KDAS 050-038	G45	For G45	ISI 28	P24	P20	-	-
Ø63	LBI 35	KDAS 063-047	G58	ForG58	ISI 35	G30	G25	-	-
Ø80	LBI 45	KDAS 080-060	G75	For G75	ISI 45	G40	G35	-	-
Ø100	LBI 56	KDAS 100-075	G95	For G95	ISI 55	G50	G45	-	-
Ø125	LBI 71	KDAS 125-100	G120	For G120	-	G60	G55	Ø70xØ90x5	G125
Ø140	LBI 90	KDAS 140-115	G135	For G135	-	G70	G65	Ø90xØ110x5	G140
Ø150	LBI 90	KDAS 150-125	G145	For G145	-	G70	G65	Ø90xØ110x5	G150
Ø160	LBI 100	KDAS 160-135	G150	For G150	-	G75	G70	Ø100xØ120x5	G160
Ø180	LBI 110	KDAS 180-155	G170	For G170	-	G80	G75	Ø110xØ130x5	G180
Ø200	LBI 125	KDAS 200-175	G190	For G190	-	G100	G95	Ø125xØ150x6	G200
Ø250	LBI 160	KDAS 250-225	G240	For G240	-	G120	G115	Ø160xØ185x6	G250

Dimensions-Axial Angle of Foot (LA)

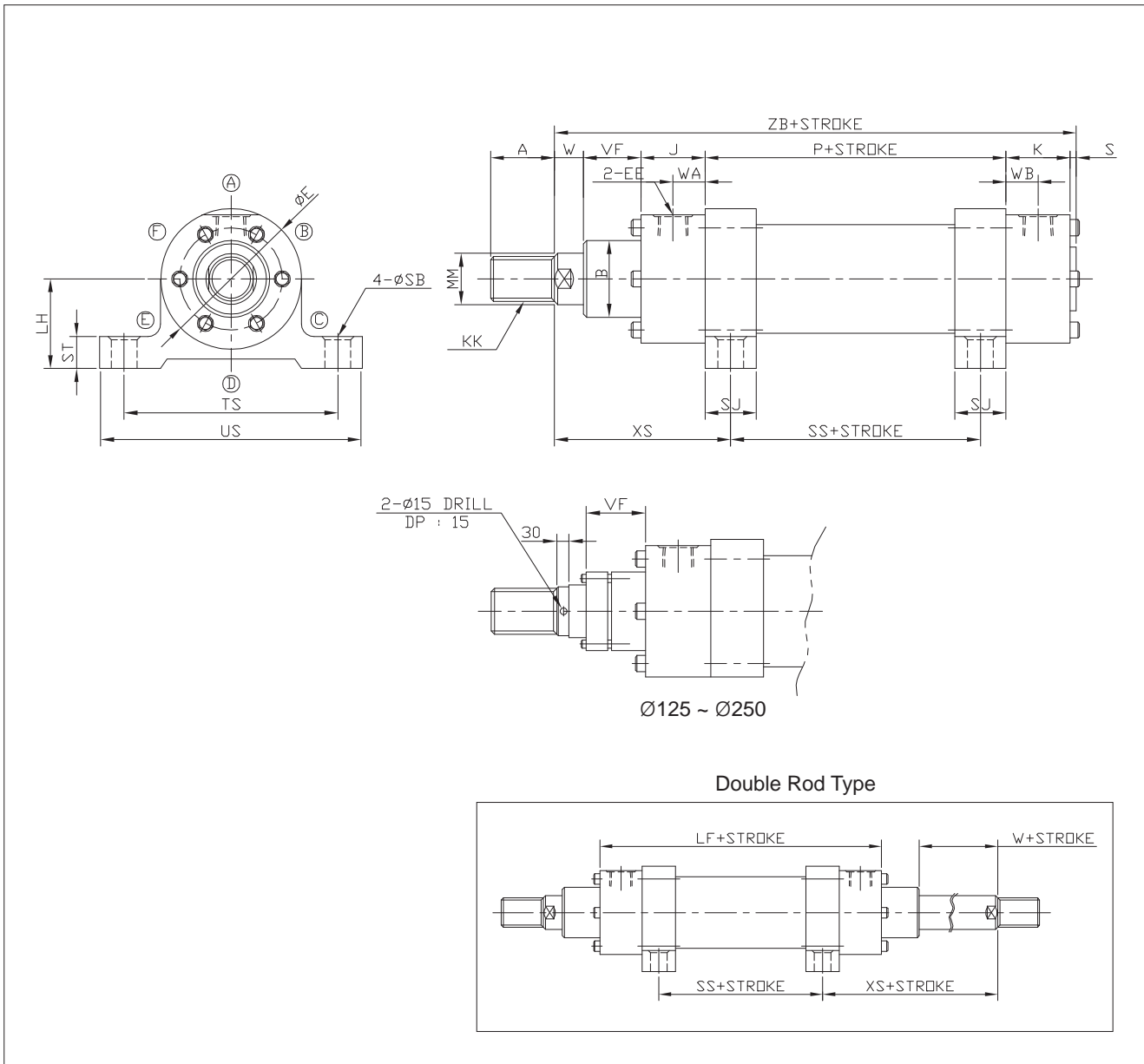

Unit : mm

Bore size	A	B	E	EE	J	K	KK	LF	LH	MM	P	S	SB	ST	SS	SJ	TS	US	VF	W	WA	WB	XS	ZB
Ø40	30	Ø55	Ø90	PF 1/2	40	45	M18x1.5	160	45±0.2	Ø20	80	7	Ø11	26	55	30	110±0.2	135	37	17	18	25	106.5	226
Ø50	35	Ø68	Ø110	PF 1/2	40	45.5	M24x1.5	162	55±0.2	Ø28	82	6.5	Ø11	31	57	34	130±0.2	155	37	21	18	27	110.5	234
Ø63	45	Ø75	Ø122	PF 3/4	45	45	M30x1.5	190	65±0.2	Ø35	100	5	Ø14	37	70	38	150±0.2	180	42	25	22.5	22.5	127	262
Ø80	55	Ø95	Ø145	PF 3/4	45	55	M39x1.5	195	75±0.2	Ø45	105	5	Ø18	42	55	54	176±0.2	216	49.5	15.5	22.5	27.5	135	275
Ø100	75	Ø115	Ø174	PF 1	55	55	M48x1.5	235	90±0.2	Ø56	125	5	Ø22	52	75	64	210±0.2	255	52	33	27.5	27.5	165	325
Ø125	95	Ø135	Ø230	PF 1 1/4	65	60	M64x2	280	115±0.2	Ø71	150	5	Ø25	60	90	58	275±0.2	320	55	42	30	30	192	377
Ø140	110	Ø155	Ø250	PF 1 1/4	70	70	M80x2	310	125±0.2	Ø90	170	5	Ø28	65	105	64	305±0.2	360	58	47	30	30	207.5	420
Ø150	110	Ø170	Ø278	PF 1 1/4	75	75	M80x2	330	145±0.2	Ø90	180	5	Ø28	65	110	68	335±0.2	390	60	50	35	35	220	445
Ø160	120	Ø180	Ø288	PF 1 1/2	75	75	M90x2	345	145±0.2	Ø100	195	10	Ø31	70	120	74	345±0.2	410	68	52	35	35	232.5	475
Ø180	140	Ø200	Ø312	PF 1 1/2	80	80	M100x2	375	160±0.2	Ø110	215	10	Ø37	80	135	78	380±0.2	455	78	52	35	40	250	515
Ø200	150	Ø215	Ø348	PF 1 1/2	80	80	M110x2	396	180±0.2	Ø125	236	5	Ø37	85	145	90	415±0.2	490	83	52	35	40	259	536
Ø250	160	Ø280	Ø432	PF 1 1/2	105	105	M120x2	484	220±0.2	Ø160	274	10	Ø52	110	174	100	530±0.2	635	124	41	40	40	320	659

Dimensions-Rod Side Flange (FA)

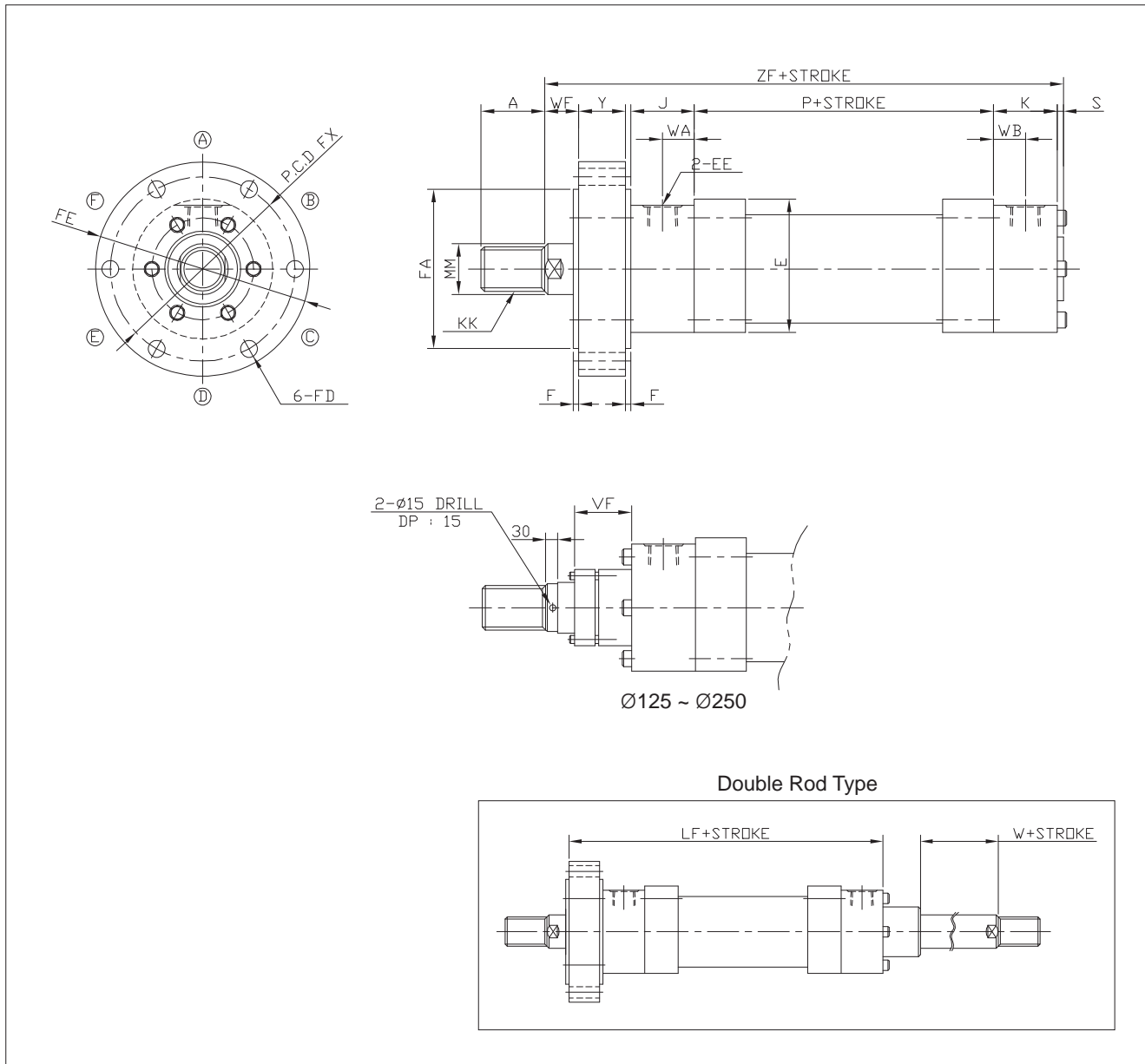

Hydraulic Cylinder
Reference Data
KP140H
KP210H
KPC70/140H
KPC210H
KTC70HP
KP140HS
KP125/160A
KP35R
KH

Unit : mm

Bore size	A	E	EE	F	FA	FD	FE	FX	J	K	KK	LF	MM	P	S	VF	W	WA	WB	WF	Y	ZF
Ø40	30	Ø90	PF 1/2	5	Ø90 ^{eB}	Ø9	Ø130	Ø108	40	45	M18x1.5	160	Ø20	80	7	37	17	18	25	19	30	226
Ø50	35	Ø110	PF 1/2	5	Ø110 ^{eB}	Ø11	Ø160	Ø130	40	45.5	M24x1.5	162	Ø28	82	6.5	37	21	18	27	23	30	234
Ø63	45	Ø122	PF 3/4	5	Ø130 ^{eB}	Ø14	Ø185	Ø155	45	45	M30x1.5	190	Ø35	100	5	42	25	22.5	22.5	27	35	262
Ø80	55	Ø145	PF 3/4	5	Ø145 ^{eB}	Ø14	Ø200	Ø170	45	55	M39x1.5	195	Ø45	105	5	49.5	15.5	22.5	27.5	25	35	275
Ø100	75	Ø174	PF 1	5	Ø175 ^{eB}	Ø18	Ø245	Ø205	55	55	M48x1.5	235	Ø56	125	5	52	33	27.5	27.5	35	45	325
Ø125	95	Ø230	PF 1 1/4	5(10)	Ø230 ^{eB}	Ø22	Ø305	Ø265	65	60	M64x2	280	Ø71	150	5	55	42	30	30	37	50	377
Ø140	110	Ø250	PF 1 1/4	10	Ø250 ^{eB}	Ø22	Ø325	Ø285	70	70	M80x2	310	Ø90	170	5	58	47	30	30	45	50	420
Ø150	110	Ø278	PF 1 1/4	10	Ø278 ^{eB}	Ø26	Ø370	Ø320	75	75	M80x2	330	Ø90	180	5	60	50	35	35	45	55	445
Ø160	120	Ø288	PF 1 1/2	10	Ø290 ^{eB}	Ø28	Ø390	Ø335	75	75	M90x2	345	Ø100	195	10	68	52	35	35	50	60	475
Ø180	140	Ø312	PF 1 1/2	10	Ø315 ^{eB}	Ø30	Ø420	Ø360	80	80	M100x2	375	Ø110	215	10	78	52	35	40	50	70	515
Ø200	150	Ø348	PF 1 1/2	10	Ø350 ^{eB}	Ø33	Ø460	Ø400	80	80	M110x2	396	Ø125	236	5	83	52	35	40	50	75	536
Ø250	160	Ø432	PF 1 1/2	10	Ø435 ^{eB}	Ø40	Ø575	Ø500	105	105	M120x2	484	Ø160	274	10	124	41	40	40	70	85	659

Dimensions-Head Side Flange (FB)

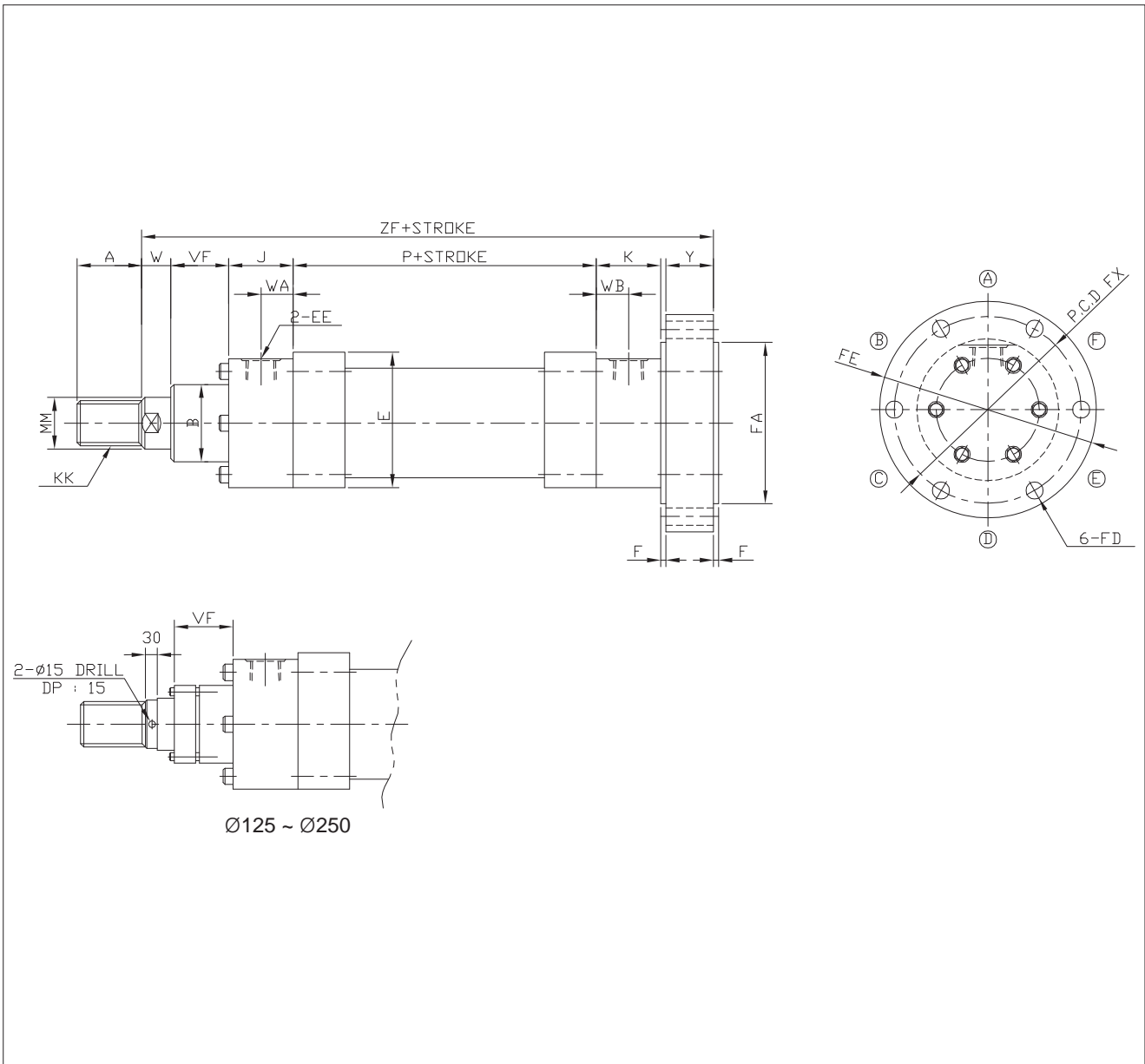

Unit : mm

Bore size	A	B	E	EE	F	FA	FD	FE	FX	J	K	KK	MM	P	VF	W	WA	WB	Y	ZF
Ø40	30	Ø55	Ø90	PF 1/2	5	Ø90 ^{EB}	Ø9	Ø130	Ø108	40	45	M18x1.5	Ø20	80	37	17	18	25	30	226
Ø50	35	Ø68	Ø110	PF 1/2	5	Ø110 ^{EB}	Ø11	Ø160	Ø130	40	45.5	M24x1.5	Ø28	82	37	21	18	27	30	234
Ø63	45	Ø75	Ø122	PF 3/4	5	Ø130 ^{EB}	Ø14	Ø185	Ø155	45	45	M30x1.5	Ø35	100	42	25	22.5	22.5	35	262
Ø80	55	Ø95	Ø145	PF 3/4	5	Ø145 ^{EB}	Ø14	Ø200	Ø170	45	55	M39x1.5	Ø45	105	49.5	15.5	22.5	27.5	35	275
Ø100	75	Ø115	Ø174	PF 1	5	Ø175 ^{EB}	Ø18	Ø245	Ø205	55	55	M48x1.5	Ø56	125	52	33	27.5	27.5	45	325
Ø125	95	Ø135	Ø230	PF 1 1/4	5(10)	Ø230 ^{EB}	Ø22	Ø305	Ø265	65	60	M64x2	Ø71	150	55	42	30	30	50	377
Ø140	110	Ø155	Ø250	PF 1 1/4	10	Ø250 ^{EB}	Ø22	Ø325	Ø285	70	70	M80x2	Ø90	170	58	47	30	30	50	420
Ø150	110	Ø170	Ø278	PF 1 1/4	10	Ø278 ^{EB}	Ø26	Ø370	Ø320	75	75	M80x2	Ø90	180	60	50	35	35	55	445
Ø160	120	Ø180	Ø288	PF 1 1/2	10	Ø290 ^{EB}	Ø28	Ø390	Ø335	75	75	M90x2	Ø100	195	68	52	35	35	60	475
Ø180	140	Ø200	Ø312	PF 1 1/2	10	Ø315 ^{EB}	Ø30	Ø420	Ø360	80	80	M100x2	Ø110	215	78	52	35	40	70	515
Ø200	150	Ø215	Ø348	PF 1 1/2	10	Ø350 ^{EB}	Ø33	Ø460	Ø400	80	80	M110x2	Ø125	236	83	52	35	40	75	536
Ø250	160	Ø280	Ø432	PF 1 1/2	10	Ø435 ^{EB}	Ø40	Ø575	Ø500	105	105	M120x2	Ø160	274	124	41	40	40	85	659



Dimensions-Single Clevis (CA)

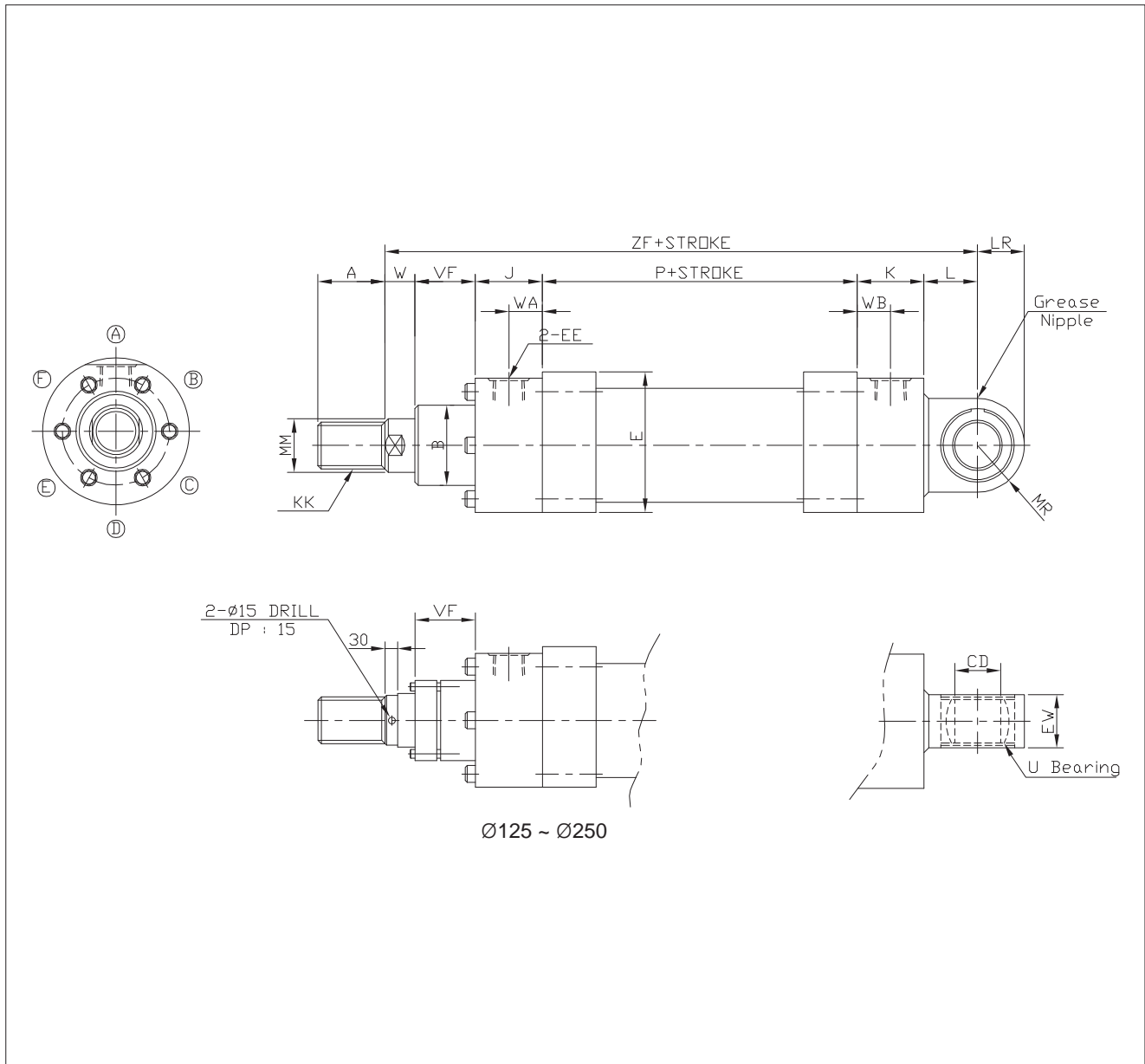

Hydraulic Cylinder
Reference Data
KP140H
KP210H
KPC70/140H
KPC210H
KTC70HP
KP140HS
KP125/160A
KP35R
KH

Unit : mm

Bore size	A	B	CD	E	EE	EW	J	K	KK	L	LR	MR	MM	P	U	VF	W	WA	WB	ZF
Ø40	30	Ø55	Ø25	Ø90	PF 1/2	23 ⁰ _{-0.3}	40	45	M18x1.5	33	-	R27.5	Ø20	80	GE25ES	37	17	18	25	252
Ø50	35	Ø68	Ø30	Ø110	PF 1/2	28 ⁰ _{-0.3}	40	45.5	M24x1.5	37.5	-	R32.5	Ø28	82	GE30ES	37	21	18	27	265
Ø63	45	Ø75	Ø35	Ø122	PF 3/4	30 ⁰ _{-0.3}	45	45	M30x1.5	45	-	R40	Ø35	100	GE35ES	42	25	22.5	22.5	302
Ø80	55	Ø95	Ø40	Ø145	PF 3/4	35 ⁰ _{-0.3}	45	55	M39x1.5	60	-	R50	Ø45	105	GE40ES	49.5	15.5	22.5	27.5	330
Ø100	75	Ø115	Ø50	Ø174	PF 1	40 ⁰ _{-0.3}	55	55	M48x1.5	65	-	R62.5	Ø56	125	GE50ES	52	33	27.5	27.5	385
Ø125	95	Ø135	Ø60	Ø230	PF 1 1/4	50 ⁰ _{-0.3}	65	60	M64x2	75	70	R65	Ø71	150	GE60ES	55	42	30	30	447
Ø140	110	Ø155	Ø70	Ø250	PF 1 1/4	55 ⁰ _{-0.3}	70	70	M80x2	75	82	R77	Ø90	170	GE70ES	58	47	30	30	490
Ø150	110	Ø170	Ø70	Ø278	PF 1 1/4	60 ⁰ _{-0.3}	75	75	M80x2	80	82	R77	Ø90	180	GE70ES	60	50	35	35	520
Ø160	120	Ø180	Ø80	Ø288	PF 1 1/2	60 ⁰ _{-0.3}	75	75	M90x2	85	95	R90	Ø100	195	GE25ES	68	52	35	35	550
Ø180	140	Ø200	Ø90	Ø312	PF 1 1/2	65 ⁰ _{-0.3}	80	80	M100x2	105	113	R105	Ø110	215	GE25ES	78	52	35	40	610
Ø200	150	Ø215	Ø100	Ø348	PF 1 1/2	70 ⁰ _{-0.3}	80	80	M110x2	114	125	R115	Ø125	236	GE25ES	83	52	35	40	645
Ø250	160	Ø280	Ø110	Ø432	PF 1 1/2	80 ⁰ _{-0.3}	105	105	M120x2	140	160	R150	Ø160	274	GE25ES	124	41	40	40	789

Dimensions-Center Trunnion (TC)

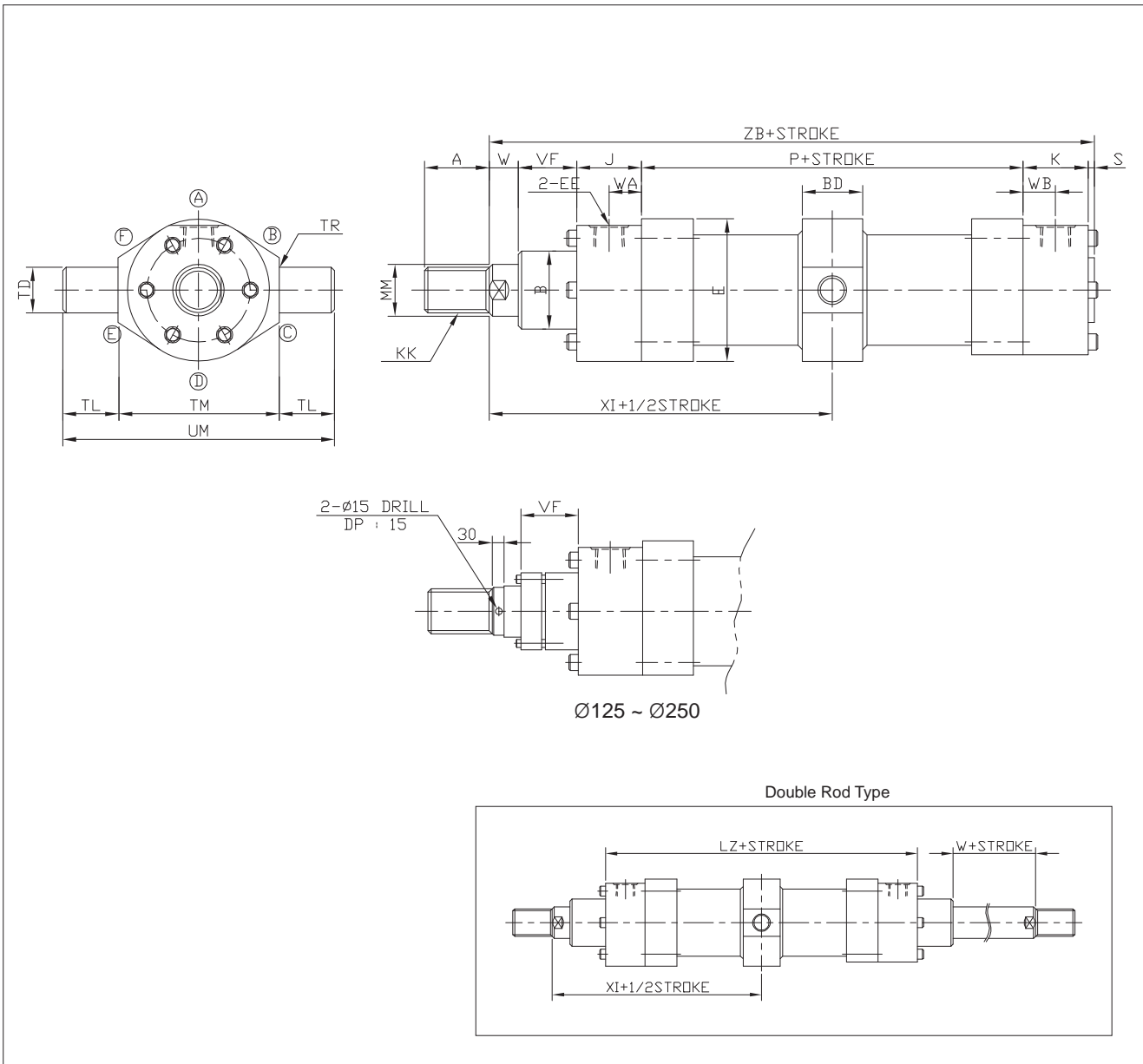

Unit : mm

Bore size	A	B	BD	E	EE	J	K	KK	LZ	MM	P	S	TD	TM	TL	TR	UM	VF	XI	W	WA	WB	ZB
Ø40	30	Ø55	38	Ø90	PF 1/2	40	45	M18x1.5	160	Ø20	80	7	Ø30 ^{EB}	95±0.2	20	R2	135	37	136	17	18	25	226
Ø50	35	Ø68	38	Ø110	PF 1/2	40	45.5	M24x1.5	162	Ø28	82	6.5	Ø30 ^{EB}	115±0.2	20	R2	155	37	143.5	21	18	27	234
Ø63	45	Ø75	43	Ø122	PF 3/4	45	45	M30x1.5	190	Ø35	100	5	Ø35 ^{EB}	130±0.2	20	R2	170	42	162	25	22.5	22.5	262
Ø80	55	Ø95	48	Ø145	PF 3/4	45	55	M39x1.5	195	Ø45	105	5	Ø40 ^{EB}	145±0.2	25	R2	195	49.5	170	15.5	22.5	27.5	275
Ø100	75	Ø115	58	Ø174	PF 1	55	55	M48x1.5	235	Ø56	125	5	Ø50 ^{EB}	175±0.2	30	R2.5	235	52	201	33	27.5	27.5	325
Ø125	95	Ø135	68	Ø230	PF 1 1/4	65	60	M64x2	280	Ø71	150	5	Ø60 ^{EB}	210±0.2	40	R2.5	290	55	237	42	30	30	377
Ø140	110	Ø155	73	Ø250	PF 1 1/4	70	70	M80x2	310	Ø90	170	5	Ø65 ^{EB}	230±0.2	42.5	R2.5	315	58	260	47	30	30	420
Ø150	110	Ø170	78	Ø278	PF 1 1/4	75	75	M80x2	330	Ø90	180	5	Ø71 ^{EB}	260±0.2	50	R2.5	360	60	270	50	35	35	445
Ø160	120	Ø180	83	Ø288	PF 1 1/2	75	75	M90x2	345	Ø100	195	10	Ø75 ^{EB}	275±0.2	52.5	R2.5	380	68	292.5	52	35	35	475
Ø180	140	Ø200	96	Ø312	PF 1 1/2	80	80	M100x2	375	Ø110	215	10	Ø85 ^{EB}	300±0.2	55	R2.5	410	78	317.5	52	35	40	515
Ø200	150	Ø215	96	Ø348	PF 1 1/2	80	80	M110x2	396	Ø125	236	5	Ø90 ^{EB}	320±0.2	55	R2.5	430	83	332.5	52	35	40	536
Ø250	160	Ø280	126	Ø432	PF 1 1/2	105	105	M120x2	484	Ø160	274	10	Ø110 ^{EB}	410±0.2	65	R2.5	540	124	407	41	40	40	659

Dimensions-Bellows Attached Type (J, K)

Ø40 ~Ø100

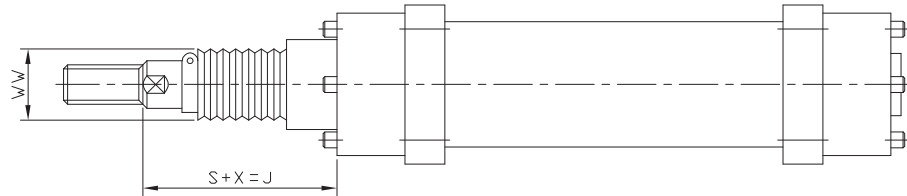

Ø125 ~Ø250

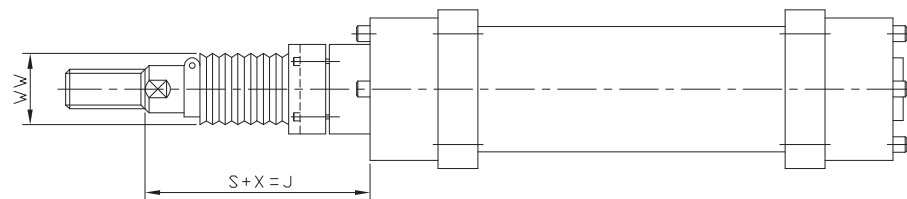

Type	J	K
Material	Nylon Tarpaulin	Neoprene Cloth
Temperature	60°C	110°C

Bore size	Ø40	Ø50	Ø63	Ø80	Ø100	Ø125	Ø140	Ø150	Ø160	Ø180	Ø200	Ø250
WW	Ø50	Ø63	Ø71	Ø80	Ø100	Ø125	Ø125	Ø140	Ø160	Ø180	Ø180	Ø200
X	75	75	85	95	95	110	115	115	125	135	140	190
S	1/3.5 × Stroke		1/4 × Stroke			1/5 × Stroke					1/6 × Stroke	

- ※ For not shown dimensions, refer to standard type.
- ※ When calculating with decimals, please round up.
- ※ SUS band is mounted at bellows at delivery.

Hydraulic Cylinder

Reference Data

KP140H

KPC210H

KPC70/140H

KPC210H

KTC70HP

KP140HS

KP125/160A

KP35R

KH

Dimensions-Accessory

Single Knuckle Joint

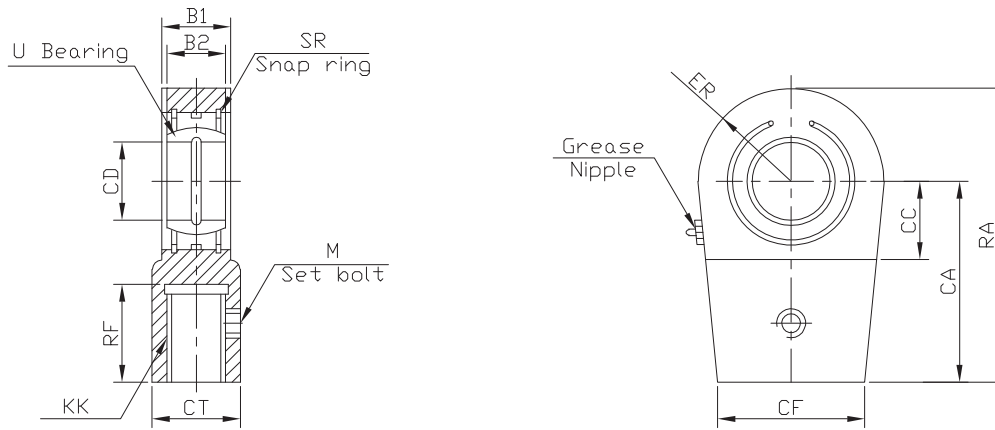

Unit : mm

Bore size	B1	B2	CA	CC	CD	CF	CT	ER	KK	M	RF	RA	SR	U
Ø40	23	20	65	25	Ø25	48	28	R28	M18x1.5	M8	32	95	R42	G25ES
Ø50	28	22	75	30	Ø30	54	34	R32	M24x1.5	M8	37	109	R47	G30ES
Ø63	30	25	90	40	Ø35	66	44	R39	M30x1.5	M8	47	132	R55	G35ES
Ø80	35	28	105	45	Ø40	78	55	R47	M39x1.5	M8	57	155	R62	G40ES
Ø100	40	35	135	55	Ø50	90	70	R58	M48x1.5	M10	77	198	R75	G50ES
Ø125	50	44	170	65	Ø60	118	87	R65	M64x2	M10	98	240	R90	G60ES
Ø140	55	49	195	75	Ø70	130	105	R77	M80x2	M12	113	278	R105	G70ES
Ø150	55	49	195	75	Ø70	152	105	R77	M80x2	M12	113	278	R105	G70ES
Ø160	60	55	210	80	Ø80	162	125	R88	M90x2	M16	123	305	R120	G80ES
Ø180	65	60	250	90	Ø90	172	150	R103	M100x2	M16	143	363	R130	G90ES
Ø200	70	70	275	105	Ø100	172	170	R115	M110x2	M20	155	400	R150	G100ES
Ø250	80	70	300	115	Ø110	194	180	R132.5	M120x2	M20	165	442.5	R160	G110ES

Principle of Operation

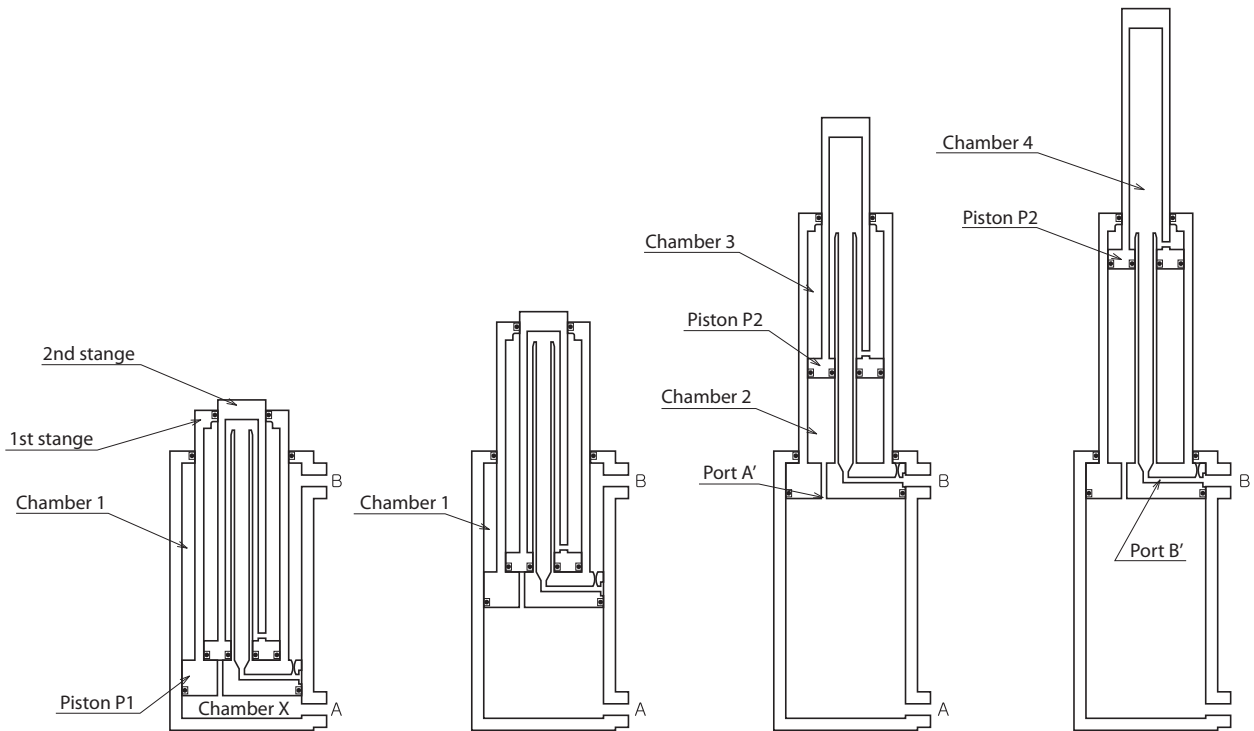

Extension

The hydraulic fluid flowing through port A enters chamber X and gives pushing force to piston P1 to actuate the 1st stage. At the same time, the fluid in chamber 1 is discharged through port B.

When piston P1 reaches the end on the rod cover side, the hydraulic fluid enters chamber 2 through port A' of piston P1 and gives force to piston P2 to actuate the 2nd stage. At the same time, the fluid in chamber 3 flows into chamber 4 through the hole in the rod connected to piston P2 and is discharged to port B as return fluid through port B' piston P1.

Retraction

The hydraulic fluid flowing through port B enters chamber 4 through port B' of piston P1 and flows into chamber 3 through the hole in the rod connected to piston P2. The hydraulic fluid flowing into chamber 3 gives force to the rod cover side of piston P2 to actuate the 2nd stage. At the same time, the fluid in chamber 2 is discharged from port A through port A'. When piston P2 reaches the cap cover side, the hydraulic fluid enters chamber 1 and gives force to the rod cover side of piston P1 to actuate the 1st stage. At the same time, the fluid in the chamber X is discharged from port A.

Hydraulic Cylinder
Reference Data
KP140H
KP210H
KPC70/140H
KPC210H
KTC70HP
KP140HS
KP125/160A
KP35R
KH

Output Characteristic Diagrams

The diagrams below show the output at the 1st and 2nd stages on the extension side and retraction side. At the pressure point A, there is an obvious difference in output between the 1st and 2nd stages. This difference is caused by a difference in sectional area.

It is clear that the output at the 1st stage is larger on the extension side and the output at the 2nd stage is larger on the retraction side. Therefore, the cylinder operations can be confirmed. On the extension side, the 1st stage operates, and the 2nd stage operates. On the retraction side, the 2nd stage operates, and then the 1st stage operates.

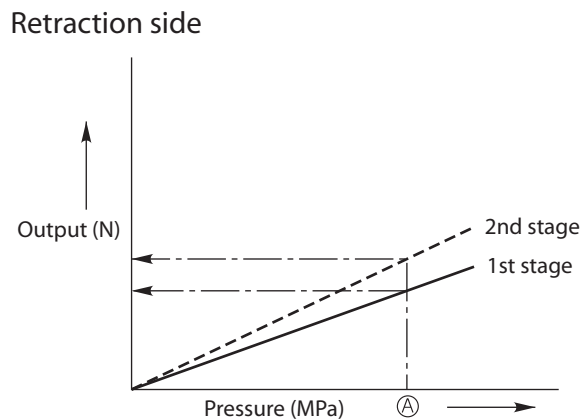
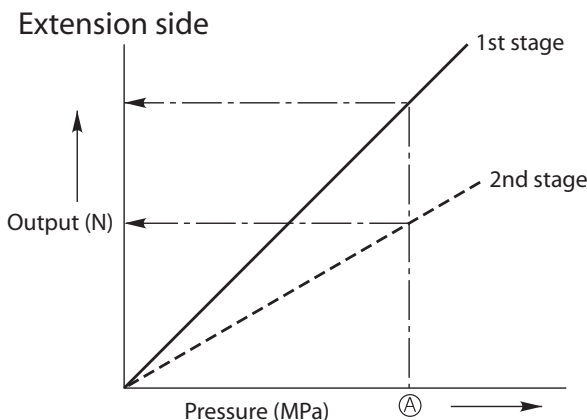

Calculation of Cylinder Force

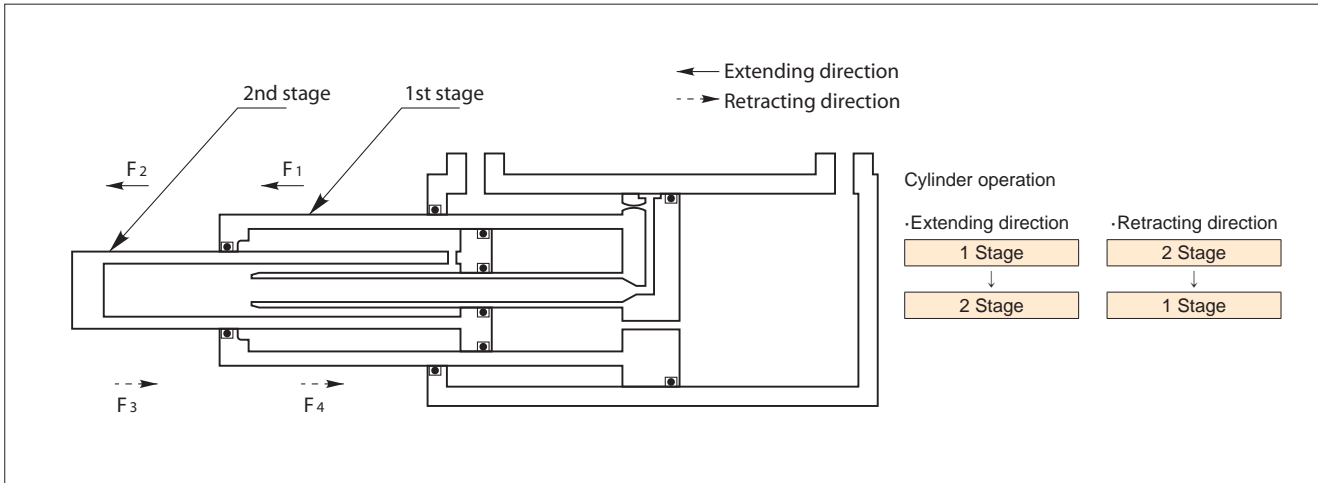

●Cylinder force in extending direction

- 1st stage: $F_1 = A_1 \times P \times \beta$ (kgf)
- 2nd stage: $F_2 = A_2 \times P \times \beta$ (kgf)

●Cylinder force in retracting direction

- 1st stage: $F_3 = A_3 \times P \times \beta$ (kgf)
- 2nd stage: $F_4 = A_4 \times P \times \beta$ (kgf)

- A1: Effective sectional area at 1st stage in extending direction (cm²)
- A2: Effective sectional area at 2nd stage in extending direction (cm²)
- A3: Effective sectional area at 1st stage in retracting direction (cm²)
- A4: Effective sectional area at 2nd stage in retracting direction (cm²)
- P : Working pressure (kgf/cm²)
- β : Load rate

The actual cylinder output should be determined in consideration of the resistance of cylinder sliding sections and the pressure loss of the piping and equipment.

The load rate refers to the ratio of the actual force applied to the cylinder to the theoretical force (theoretical cylinder force) calculated from the circuit set pressure. Generally, the load rate should be in the following range.

When the inertia force is low: 60 to 80%

When the inertia force is high: 25 to 35%

(For the calculation examples shown in this catalogue, a load rate of 80% is used.)

Table of Piston Effective Sectional Area Unit:cm²

Direction Type	Extending direction		Retracting direction	
	1 stage	2 stage	1 stage	2 stage
Type 10	31.17	15.12	9.11	9.39
Type 20	63.62	31.42	19.44	20.07
Type 30	95.03	47.72	31.42	31.82
Type 40	122.72	61.07	39.40	39.84
Type 50	153.94	76.00	48.25	48.66

<Example>

Determine the cylinder force at the 1st and 2nd stages in the extending and retracting directions when type 10 double acting telescopic cylinder is used at a set pressure of 70kgf/cm².

<Answer>

Cylinder force in extending direction (kgf)

-1st stage = Set pressure(kgf/cm²) x Piston effective sectional area at 1st stage in extending direction(cm²) x Load rate
= 70 x 31.2 x 0.8 = 1,747(kgf)

-2nd stage = Set pressure(kgf/cm²) x Piston effective sectional area at 2nd stage in extending direction(cm²) x Load rate
= 70 x 15.1 x 0.8 = 845(kgf)

Cylinder force on retracting direction (kgf)

-2nd stage = Set pressure(kgf/cm²) x Piston effective sectional area at 2nd stage in retracting direction(cm²) x Load rate
= 70 x 9.4 x 0.8 = 526(kgf)

-1st stage = Set pressure(kgf/cm²) x Piston effective sectional area at 1st stage in retracting direction(cm²) x Load rate
= 70 x 9.1 x 0.8 = 509(kgf)

<Example>

Select an optimum type of double acting telescopic cylinder to obtain a cylinder force of 1000kgf at the 1st stage in the retracting direction at a set pressure of 7 kgf/cm².

Determine the cylinder force at the 1st and 2nd stages in the extending and retracting directions when the selected cylinder is used.

<Answer>

$$\text{Piston effective sectional area (cm}^2\text{)} = \frac{\text{Cylinder force(kgf/cm}^2\text{)}}{\text{Set pressure(kgf/cm}^2\text{)} \times \text{Load rate}}$$

$$= \frac{1,000}{70 \times 0.8} \approx 17.86$$

When you select a cylinder bore larger than 17.86 from the rod cover side 1st stage column in the table of piston effective sectional area, then type 20 is selected.

Cylinder Force at Each Stage

Extending direction:

Cylinder force at 1st stage= 70 x 63.62 x 0.8=3,562.72kgf
Cylinder force at 2nd stage= 70 x 31.42 x 0.8=1,759.52kgf

Retracting direction:

Cylinder force at 2nd stage= 70 x 19.44 x 0.8=1,088.64kgf
Cylinder force at 1st stage= 70 x 20.07 x 0.8=1,123.92kgf

How To Read Buckling Chart

How to determine the max. working load according to the telescopic cylinder type

1. Determine in which condition the telescopic cylinder is mounted among ① to ⑨ shown below.
2. After determining the mounting condition, obtain the value L for the condition.
3. Determine the max. working load according to the value L and the telescopic cylinder type from the buckling chart.

How to determine the max. stroke according to the telescopic cylinder type

1. Determine in which condition the telescopic cylinder is mounted among ① to ⑨ shown below.
2. Determine the value L according to the max. working load and the telescopic cylinder type from the buckling chart.
3. After the mounting condition is determined, the stroke can be obtained from the value L.

Mounting Conditions

Pin Joint at Both Ends

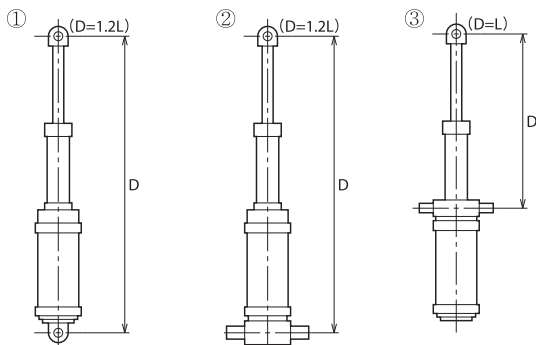

Fixed Telescopic Cylinder and Free Rod End (D=L/1.45)

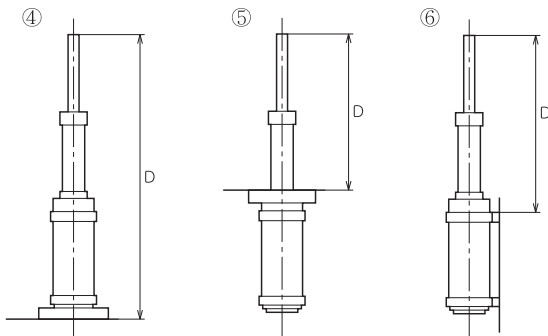

Fixed Telescopic Cylinder and Rod End Guide (D=1.6L)

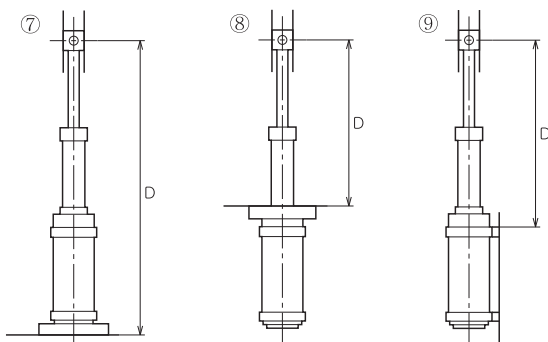

Notes on calculation of piston rod buckling

Before calculating the piston rod buckling, it is necessary to examine the method of stopping the cylinder. There are two ways to stop a cylinder: the cylinder stopping method, where the cylinder is stopped at the cylinder stroke end, and the external stopping method, where the cylinder is stopped by an external stopper. The way of determining the load varies depending on the method.

Way of determining the load in the case of cylinder stopping method

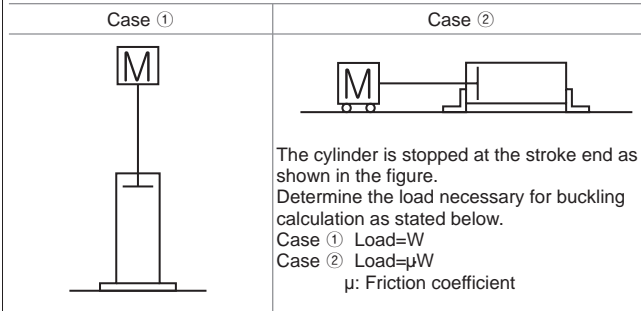

Way of determining the load in the case of external stopping method

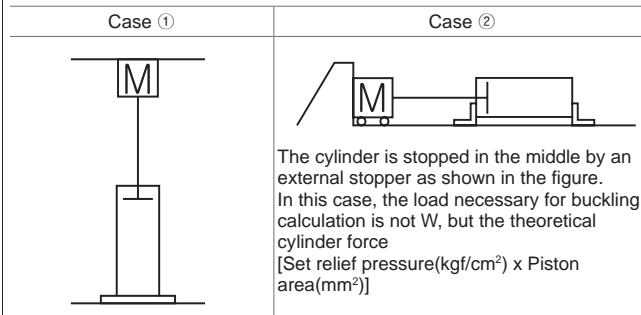

Buckling Chart

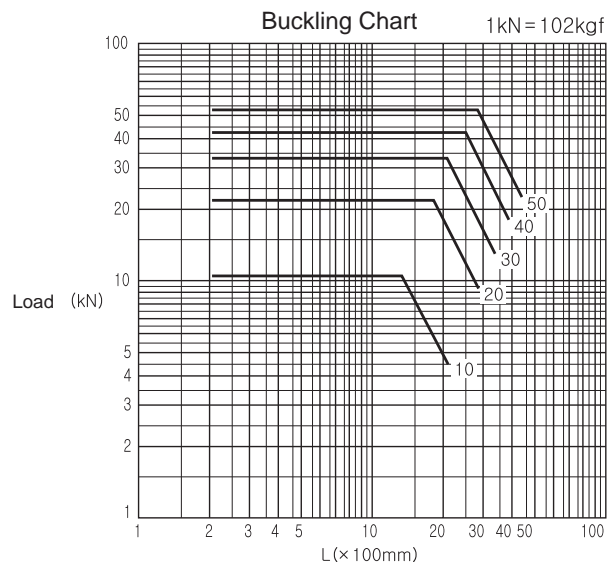

Load Weight-Speed Diagram of Each Series Based on Cushioning Characteristics

The above diagram shows the target speed on a uniform speed circuit in the extending direction. On an ununiform speed circuit, the speed of the 2nd stage piston rod conforms to the above diagram. In the retracting direction, a load weight 1.5 times higher can be applied at the speed of the 1st stage piston rod.

· Load Weight-Speed Diagram (for horizontal transfer)

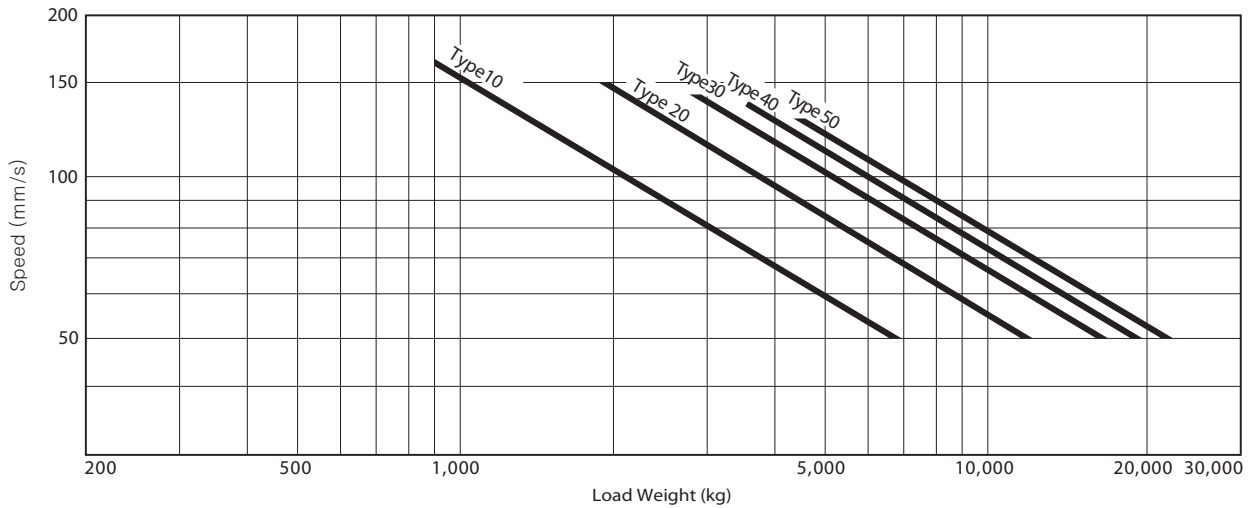

- For selection of a hydraulic cylinder, the relationship between load weight and speed is a key point.
- The above diagram is a speed diagram based on the characteristics of the rod cover side (ISO type: head side) cushion in the telescopic cylinder.

Calculation of Cylinder Stroke & Most Retracted Size

The cylinder stroke and most retracted size can be calculated from the most extended size of a telescopic cylinder.

<Calculation>

- $(\text{Most extended size} - \text{Fixed length}) / 3 + (\text{Fixed length}) = \text{Most retracted size (mm)}$
- $(\text{Most retracted size} - \text{Fixed length}) \times 2 + \text{Cylinder stroke (mm)}$

Fixed Length

Mounting style	Unit:mm			
	LA, LT, FA, TA	FB	TB	CA
Type 10	170	180	191	222
Type 20	235	250	260	310
Type 30	275	295	305	368
Type 40	315	335	355	425
Type 50	355	377	399	475

※ The fixed length is obtained by subtracting the stroke/2 from the maximum external size of the cylinder in a retracted state.

LA

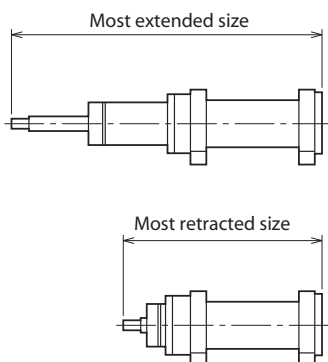

FA

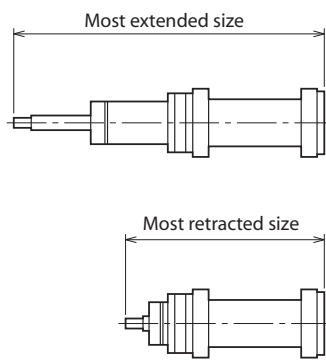

CA

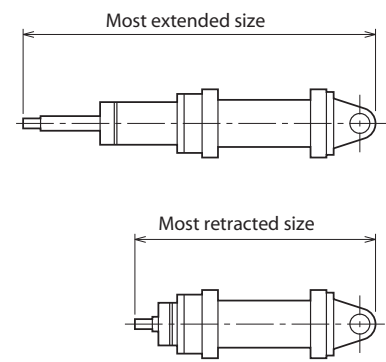

For LT, FB, TA and TB styles, calculate the size in the same method.

Confirmation of Port Diameter According to Cylinder Speed

The cylinder speed depends on the amount of fluid flowing into the cylinder. Therefore, it is necessary to confirm that the standard port diameter is appropriate. The cylinder speed V is determined by the following formula.

$$V = 1.67 \times 10^4 \times QC / A \text{ (mm/s)}$$

Qc: Amount of fluid supplied into cylinder (l/min)
A : Piston effective sectional area (mm²)
1st stage in extending direction
2nd stage in retracting direction

<Example>

Ascertain whether type 20 double acting telescopic cylinder with the standard port diameter can be used when the speed in the extending direction is 100 mm/s. Determine the pipe flow velocity (m/s). Ascertain whether the cylinder can be used when the speed in the retracting direction is 100 mm/s.

<Answer>

Draw a line parallel to the horizontal axis from the intersection of the line of cylinder speed of 100 mm/s with the line of type 20, and connect the line with the line of port 1/2B (Type 20 double acting telescopic cylinder with standard port diameter). Since the intersection of the port diameter with the cylinder speed and type is within the usable range, the cylinder can be used. The pipe flow velocity indicated by the vertical line from the intersection of the port diameter is 4.0 m/s. In the retracting direction, the velocity is 2.0m/s when two ports are used.

Cylinder Speed -Required Flow Rate-Pipe Flow Velocity Diagram

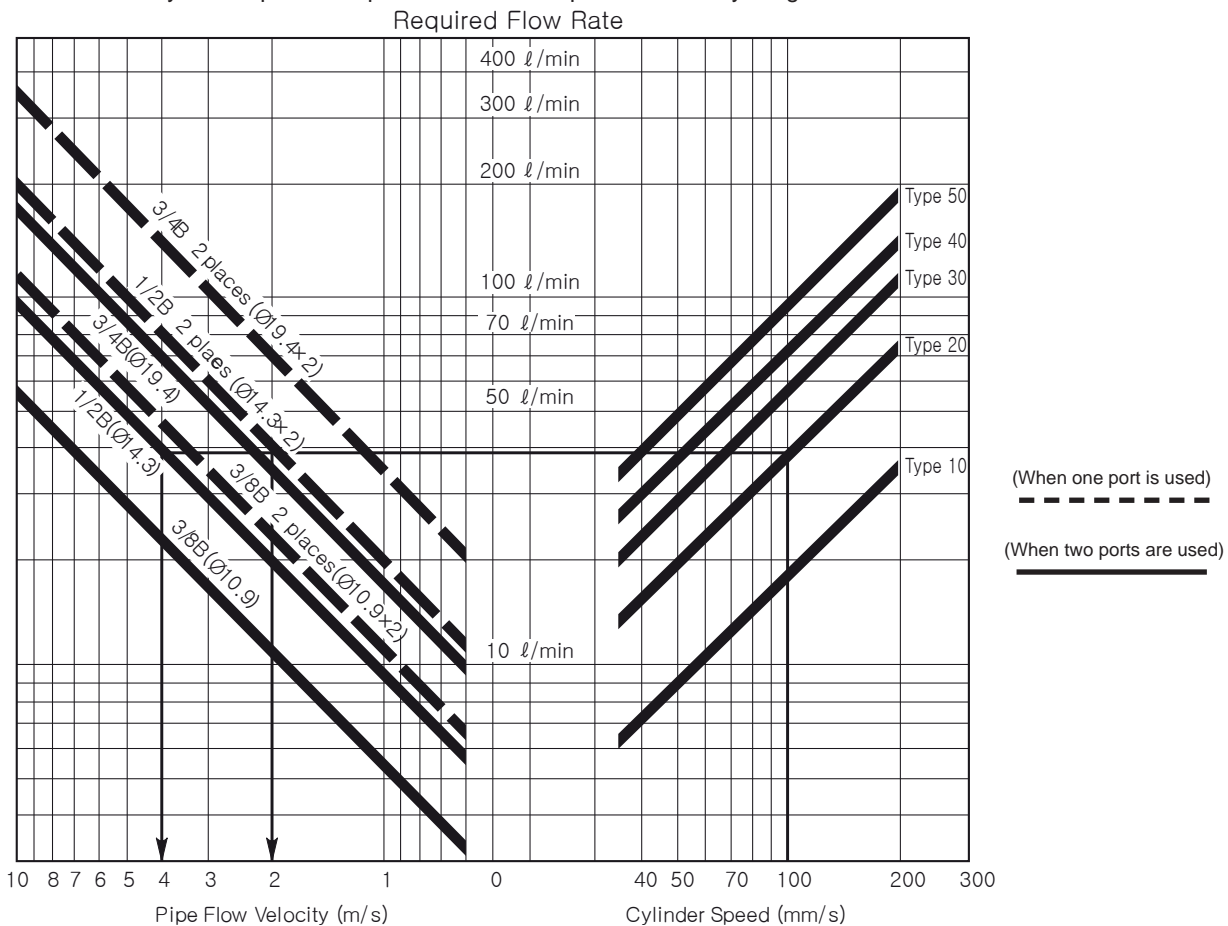

The above diagram shows the relationship between speed and required flow rate for each size of double acting telescopic cylinder and the relationship between required flow rate and pipe flow velocity for each port diameter.

(* The pressure loss can be reduced by using one size larger piping. The flow velocity was calculated with Sch80 steel pipe for piping.)

Min. Required Amount of Fluid for Cylinder	Unit: t
Type	Min. required amount of fluid
Type 10	$1.39 \times 10^{-3} \times \text{Stroke (mm)}$
Type 20	$2.78 \times 10^{-3} \times \text{Stroke (mm)}$
Type 30	$3.98 \times 10^{-3} \times \text{Stroke (mm)}$
Type 40	$5.23 \times 10^{-3} \times \text{Stroke (mm)}$
Type 50	$6.65 \times 10^{-3} \times \text{Stroke (mm)}$

Telescopic Cylinder Port Diameter

Series	Type 10	Type 20	Type 30	Type 40	Type 50
Port dia. Rc(PT)	3/8	1/2	1/2	3/4	3/4

- The minimum required amount of fluid for cylinder refers to the amount of fluid obtained by subtracting the amount of fluid on the outlet side of the cylinder from the amount of fluid on the supply side at the maximum cylinder stroke.
- In the usable range, the pipe flow velocity is less than 7 m/s. Normally, when the pipe flow velocity exceeds 7 m/s, the piping resistance and the pressure loss are increased, and, as the result of this, the output is decreased when the cylinder operates, and the speed is reduced.
- When the cylinder is used at 60kgf/cm² in the retracting direction, the discharge flow rate on the cap cover side should be less than 3.5 m/s. When it is used at 140kgf/cm² in the retracting direction, the discharge flow rate should be less than 5.5 m/s.
- Please select Rc(PT)3/4 head side port size for Ø30 cylinder in case of cylinder retracting speed is over 80mm/s.

Hydraulic Cylinder

Reference Data

KP140H

KP210H

KPC70/140H

KPC210H

KTC70HP

KP140HS

KP125/160A

KP35R

KH

Precautions

- Do not apply load to the ram tube end at the 1st stage. Doing so may cause operation failure.
- Avoid applying side load to the piston rod when operating. Doing so can cause operation failure or damage to the cylinder. If side load is applied, provide guides or protect the rod end threads. In such case, consult KCC.
- Correctly center the piston rod axis in the load moving direction. Incomplete centering can cause operation failure and damage to the cylinder.
- In the case of mounting style TA, TB or CA, center the rotation axis and the mating mount.
- Correctly fit the mounting bracket of mounting style TA or TB as shown below.

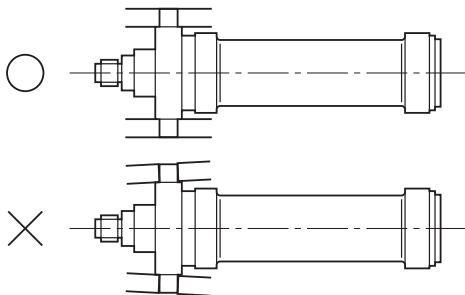

- Ensure that the mounting block has a sufficient rigidity to prevent occurrence of deflection from the cylinder thrust force.
- Use mounting bolts of strength class of JIS8.8 or more. For the tightening torque, see the following table. Incomplete tightening can cause looseness and damage of the bolts.

Tightening Torque Table

Unit: N·m

Thread dia.	Strength class	M8	M10	M12	M14	M16
Tightening torque	10.9	36	72	125	198	305
	8.8	25	51	89	141	216
Thread dia.	Strength class	M18	M20	M22	M24	
Tightening torque	10.9	420	590	800	1020	
	8.8	290	410	560	720	

- Take care that eccentric load is not applied to the piston rod when connecting the rod end attachment and load.

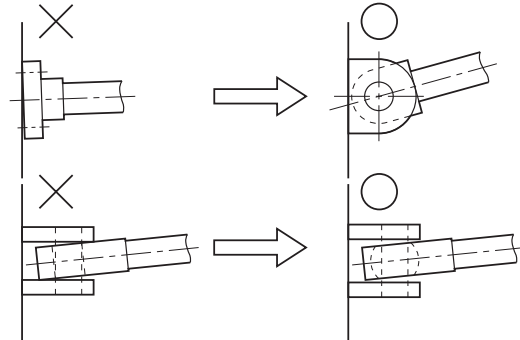

- The piston rod is made from a hollow pipe. Therefore, when fitting a rod end attachment, provide a stopper on the spigot of the thread end as shown in the figure.

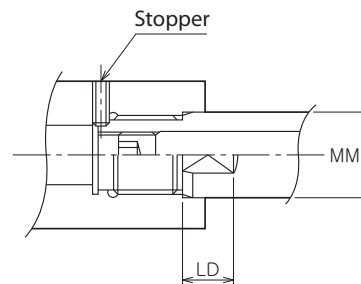

Precautions for piping

- When the cylinder is used by meter-out control on the rod side (ISO type: head side), the pressure resistance of the piping (rubber hose, etc.) used and the rod side (ISO type: head side) should be three times or more higher than the max. working pressure on the cap side (ISO type: cap side).
- Before connecting the piping, flush the inside of the piping.
- When connecting with a rubber hose, do not bend the hose at an angle less than the specified radius.
- Take care that air is not collected in the middle of the piping.

Applications

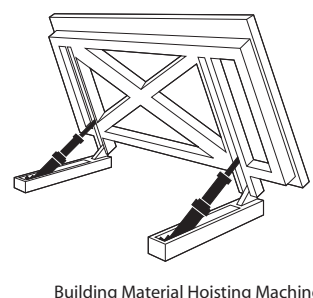
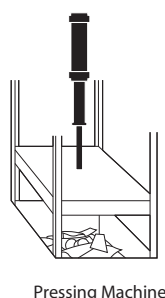
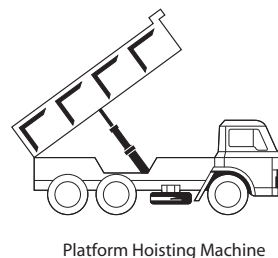
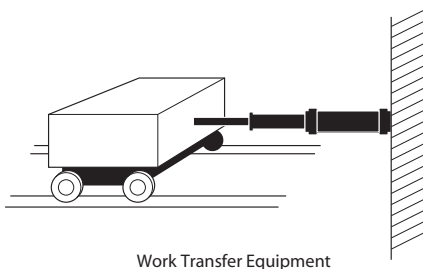

KTC70HP series



Features

- Telescopic single acting constant speed cylinder.
- 2-stage stroke cylinder requires less space for installation in the axial direction.
- Both stroke ends are provided with fixed cushions.

Symbol

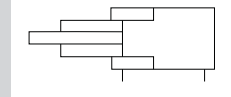

How to Order

KTC 70HP - **LA** **20** - **A** **1500** **C** **A**

① ② ③ ④ ⑤ ⑥ ⑦

① Series

KTC 70HP	Telescopic cylinder
----------	---------------------

② Mounting style

LA	Axial angle of foot	CA	Single clevis
LT	Base mounting axial angle of foot	TA	Rod side trunnion
FA	Rod side flange	TB	Head side trunnion
FB	Head side flange		

③ Type

Type	Type	Bore size	
		1 stage	2 stage
10	Type 10	Ø63	Ø45
20	Type 20	Ø90	Ø65
30	Type 30	Ø110	Ø80
40	Type 40	Ø125	Ø90
50	Type 50	Ø140	Ø100

④ Rod end thread length(dimension A)

Type	A	B
	(Standard)	(Semi-standard)
Type 10	25mm	35mm
Type 20	35mm	45mm
Type 30	40mm	55mm
Type 40	45mm	60mm
Type 50	52mm	72mm

⑤ Cylinder stroke

Type	Stroke
Type 10	50~1700
Type 20	50~2500
Type 30	50~3100
Type 40	50~3100
Type 50	50~3100

- ※ Check buckling, as it varies depending on mounting style.
- ※ Contact us for longer stroke.
- ※ Max. stroke is 50mm.

⑥ Port position

C,G	Standard
A,B,D,E,F,H	Refer to figure below according to mounting style.

⑦ Air vent position

A	Standard
B,C,D,E,F,G,H	Refer to figure below according to mounting style.

Mounting style LA, LT

The standard port positions are C and G, and the standard air vent position is A.

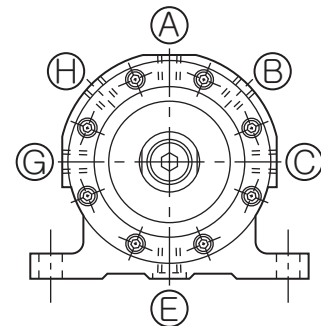

Mounting style FA, FB, CA, TA, TB

The standard port positions are A and E, and the standard air vent position is C.

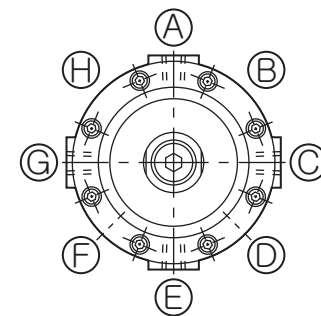

Note) Locate the ports and air vent at a distance of 90° or 180° from one another.

Specifications

Type		Type 10	Type 20	Type 30	Type 40	Type 50
Bore size	1 Stage	Ø63	Ø90	Ø110	Ø125	Ø140
	2 Stage	Ø45	Ø65	Ø80	Ø90	Ø100
Operating pressure		70kgf/cm ² (7MPa)				
Max. operating pressure		Rod side:150kgf/cm ² (15MPa)			Head side:90kgf/cm ² (9MPa)	
Proof pressure		Rod side:210kgf/cm ² (21MPa)			Head side:140kgf/cm ² (14MPa)	
Min. operating pressure		Rod side:6kgf/cm ² (0.6MPa)			Head side:3kgf/cm ² (0.3MPa)	
Operating piston speed		10m/min	9m/min	8.4m/min	7.7m/min	7.1m/min
Min.operating piston speed		0.06m/min				
Fluid temperature		-5 ~ 80℃ (No freezing)				
Ambient temperature		-10 ~ 50℃				
Working oil		Petroleum-based fluid				
Tolerance of thread		KS class 2				
Tolerance of stroke		0~1000 ^{+2.8} ₀	1001~1600 ^{+3.2} ₀	1601~2500 ^{+3.6} ₀	2501~3100 ^{+4.0} ₀	
Mounting style		LA, LT, FA, FB, CA, TA, TB				

- * 60kgf/cm² is standard pressure when cylinder is in reverse operation with common speed.
- * Operating pressure: Max. allowable setting pressure for a relief valve while cylinder is operating.
- * Max. operating pressure: Maximum allowable pressure generated in a cylinder (surge pressure, etc.)
- * Proof pressure: Test pressure a cylinder can withstand without unreliable performance when returning to operating pressure.
- * Min. operating pressure: Minimum pressure for a cylinder installed horizontally and operating without load.

Mass

Unit : kg

Type	Basic mass (SD)	Mounting mass							Additional mass for each 1mm stroke
		LA	LT	TA	TB	FA	FB	CA	
Type 10	5.7	0.44	0.37	1.08	1.08	0.93	0.93	0.32	0.0084
Type 20	15.4	1.25	1.05	3.06	3.06	2.85	2.85	0.91	0.0169
Type 30	27.0	2.29	1.93	5.61	5.61	4.88	4.88	1.66	0.0212
Type 40	41.4	3.52	2.22	8.64	8.64	7.43	7.43	2.56	0.0313
Type 50	57.2	4.92	4.14	11.99	11.99	10.24	10.24	3.55	0.0431

Calculation:

Ex) KTC70HP-FB30-A1500
 Basic mass: 27.0 / Additional mass: 0.0212 / Cylinder stroke: 1,500mm / FB type: 4.88
 $27.0 + (0.0212 \times 1500) + 4.88 = 63.68 \text{ kg}$

Structure

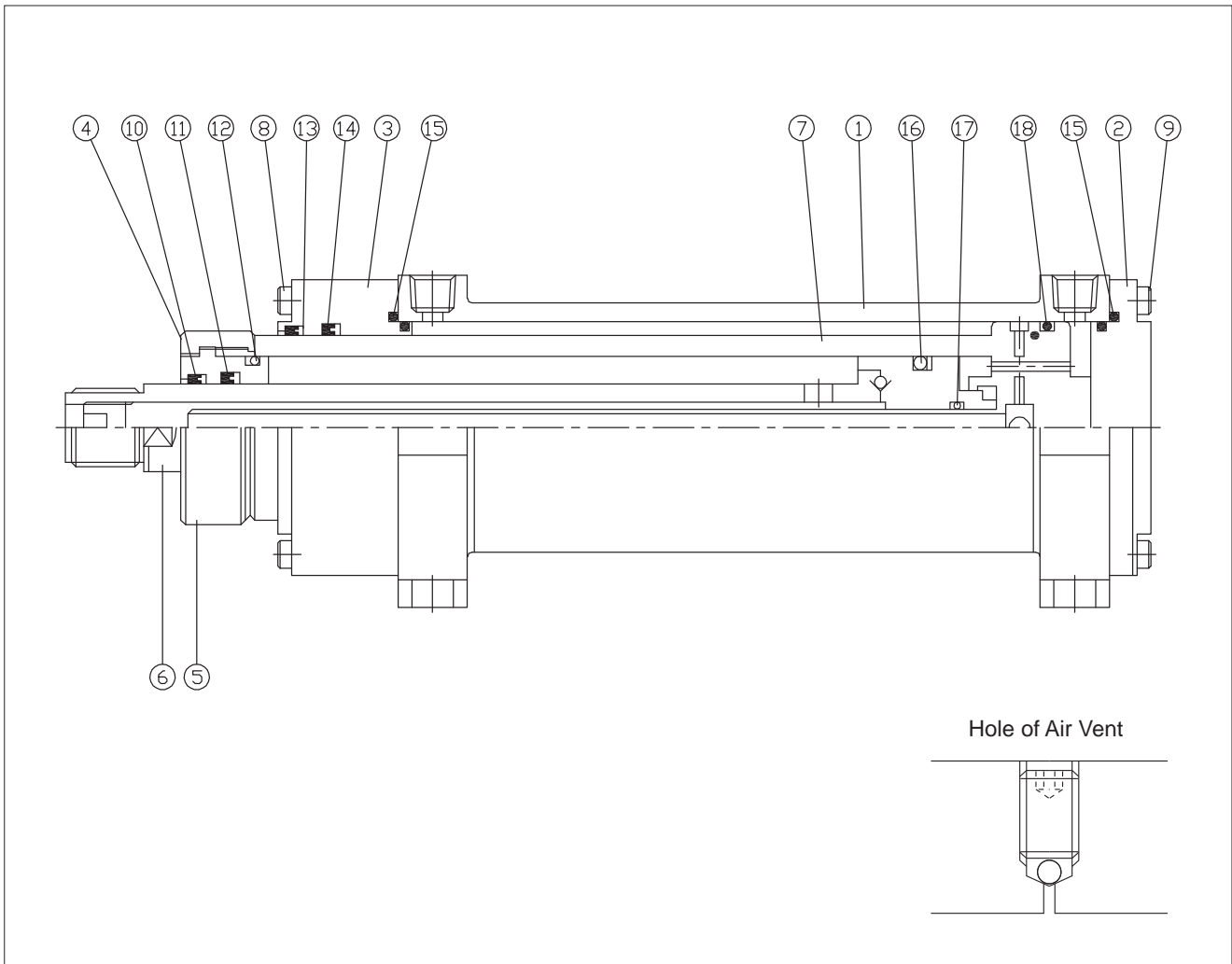

Hydraulic Cylinder
Reference Data
KP140H
KP210H
KPC70/140H
KPC210H
KTC70HP
KP140HS
KP125/160A
KP35R
KH

Part List

Part no.	Parts	Material	Quantity
1	Tube	STKM13C	1
2	Head Cover	S45C	1
3	Rod Cover	S45C	1
4	Bush	BC3	1
5	Bush Cover	S45C	1

Part no.	Parts	Material	Quantity
6	Piston & Rod	S45C	1
7	Piston & Rod	S45C(STPG38)	1
8	Socket Bolt	SCM440	8
9	Socket Bolt	SCM440	8

Packing List

Part no.	10	11	12	13	14	15	16	17	18
Parts	Dust Seal	R/Packing	O-Ring	Dust Seal	R/Packing	O-Ring	O-Ring & Packing	R/Packing	O-Ring & Packing
Material	NBR	NBR	NBR	NBR	NBR	NBR	NBR	NBR	NBR
Quantity	1	1	1	1	1	2	1	2	1
Type	Type 10	Type 20	Type 30	Type 40	Type 50	Type 10	Type 20	Type 30	Type 40
	SDR28	SKY28	G40	SDR53	SKY53	G58/G63	P39	16x24x5	P53
	SDR40	SKY40	G60	SDR75	SKY75	G85/G90	65x49x20.5	16x24x5	90x70x22.4
	SDR45	SKY45	G75	SDR90	SKY90	G105/G110	80x60x22.4	16x24x5	110x85x22.4
	SDR53	SKY53	G85	SDR106	SKY106	G120/G115	90x70x22.4	16x24x5	125x100x25.4
	SDR60	SKY60	G95	SDR118	SKY118	G135/G140	100x75x22.4	16x24x5	140x115x22.4

Dimensions-Axial Angle of Foot (LA)

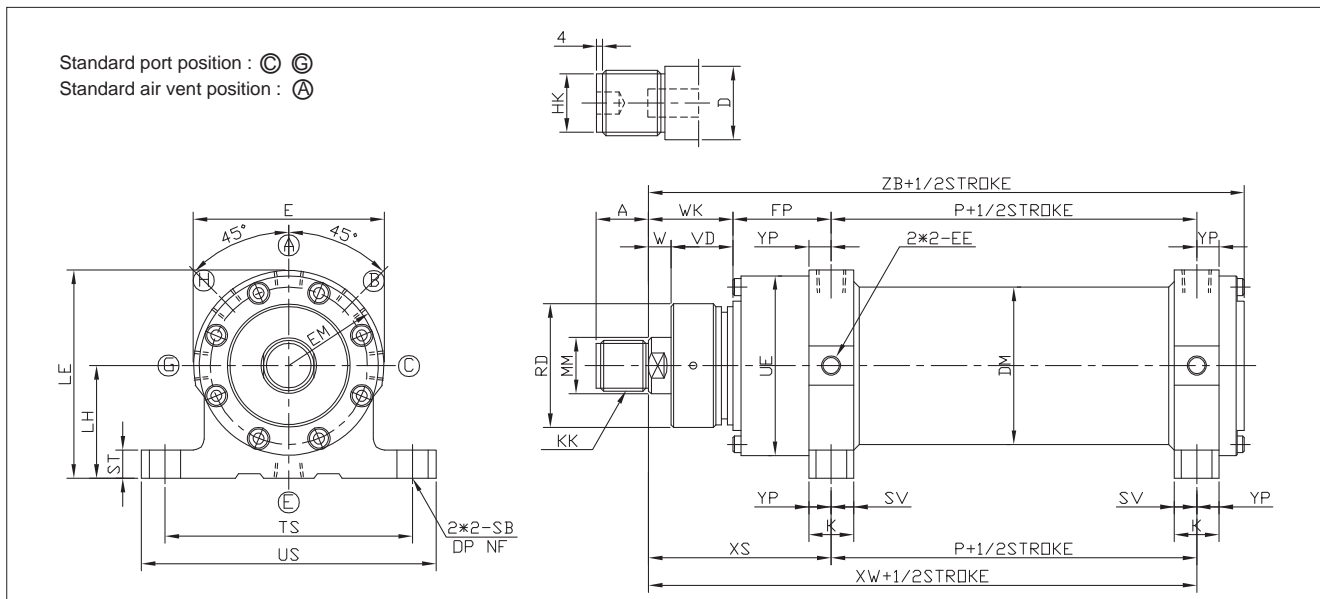

Dimensions-Base Mounting Axial Angle of Foot (LT)

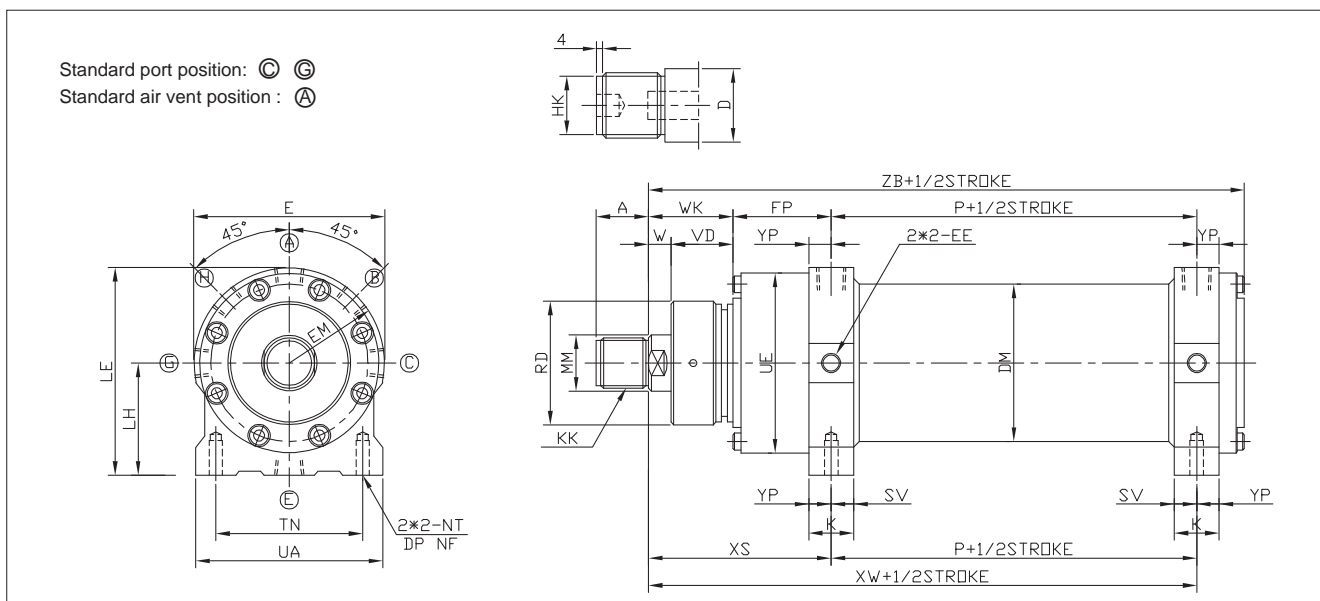

Unit : mm

Type	A	D	DM	E	EE	EM	FP	HK	K	KK	LE	LH	MM	NF	NT	P
Type 10	25	24	Ø73	98	Rc(PT)3/8	51	48	Ø21 ^{H9}	26 ⁰ _{-0.1}	M24x2	99	50 ^{±0.2}	Ø27	18	M12	25
Type 20	35	32	Ø105	138	Rc(PT)1/2	71	67	Ø30 ^{H9}	34 ⁰ _{-0.1}	M33x2	139	70 ^{±0.2}	Ø38	24	M16	35
Type 30	40	41	Ø125	158	Rc(PT)1/2	81	80	Ø36 ^{H9}	42 ⁰ _{-0.1}	M39x2	164	85 ^{±0.2}	Ø45	30	M20	40
Type 40	45	46	Ø145	178	Rc(PT)3/4	92	93	Ø46 ^{H9}	47 ⁰ _{-0.1}	M45x2	184	95 ^{±0.2}	Ø52	36	24	45
Type 50	52	55	Ø165	196	Rc(PT)3/4	100	107	Ø49 ^{H9}	48 ⁰ _{-0.1}	M52x2	203	105 ^{±0.2}	Ø59	36	24	50

Type	RD	SB	ST	SV	TN	TS	UA	UE	US	VD	W	WK	XS	XW	YP	ZB
Type 10	Ø59	Ø13.5	10	13	75	110	98	Ø89.5	130	32	13	45	93	118	13	145
Type 20	Ø84	Ø18	16	17	105	150	138	Ø129	180	43	17	60	127	162	17	200
Type 30	Ø100	Ø22	20	22	115	175	158	Ø155	210	50	20	70	150	190	20	235
Type 40	Ø112	Ø24	22	23	130	205	178	Ø177	240	57	23	80	173	218	24	270
Type 50	Ø128	Ø26	24	23	150	230	196	Ø193	270	65	25	90	197	247	25	303

Dimensions-Rod Side Flange (FA)

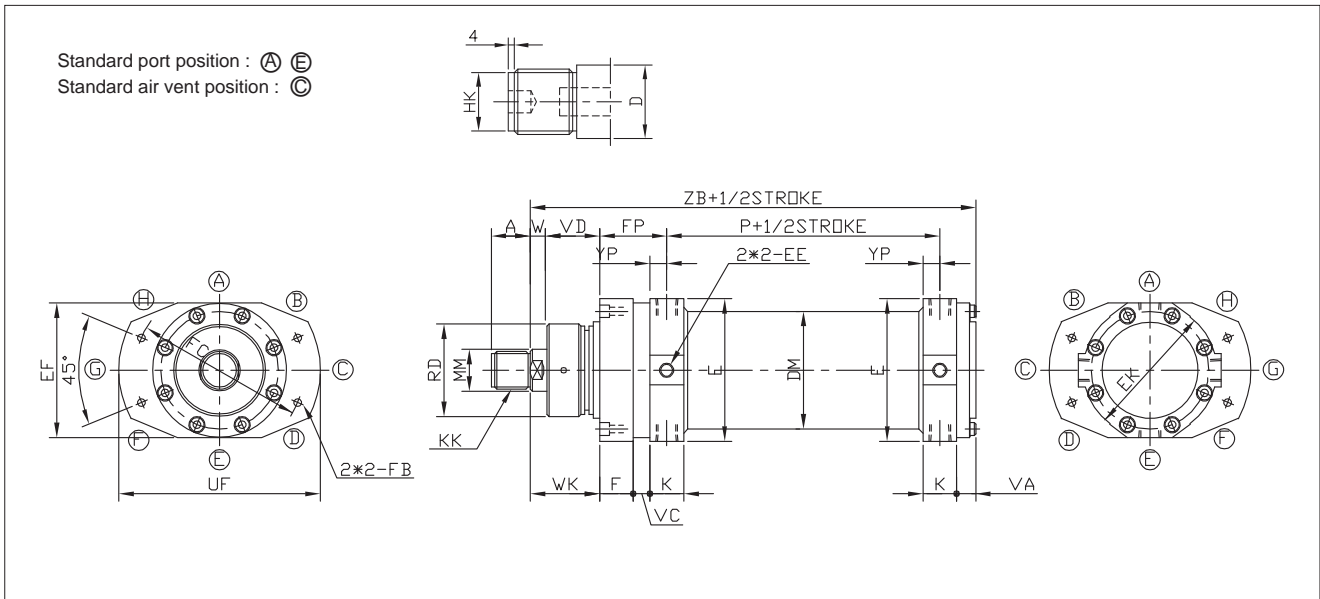

Dimensions-Head Side Flange (FB)

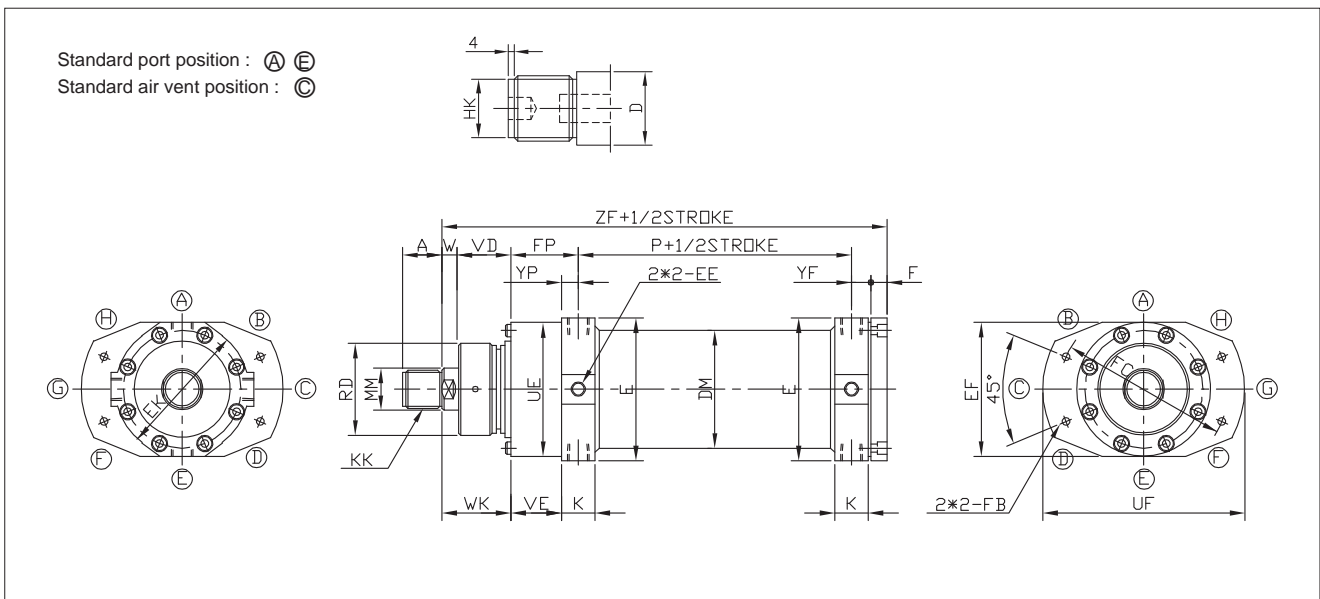

Unit : mm

Type	A	D	DM	E	EE	EF	EK	F	FB	FC	FP	HK	K	KK	MM	P	RD
Type 10	25	24	Ø73	98	Rc(PT)3/8	98	95	20	Ø9	Ø120	48	Ø21 ^{H9}	26 ⁰ _{-0.1}	M24x2	Ø27	25	Ø59
Type 20	35	32	Ø105	138	Rc(PT)1/2	138	136	30	Ø13.5	Ø170	67	Ø30 ^{H9}	34 ⁰ _{-0.1}	M33x2	Ø38	35	Ø84
Type 30	40	41	Ø125	158	Rc(PT)1/2	165	161	35	Ø16	Ø195	80	Ø36 ^{H9}	42 ⁰ _{-0.1}	M39x2	Ø45	40	Ø100
Type 40	45	46	Ø145	178	Rc(PT)3/4	190	183	40	Ø18	Ø225	93	Ø46 ^{H9}	47 ⁰ _{-0.1}	M45x2	Ø52	45	Ø112
Type 50	52	55	Ø165	196	Rc(PT)3/4	205	200	45	Ø20	Ø245	107	Ø49 ^{H9}	48 ⁰ _{-0.1}	M52x2	Ø59	50	Ø128

Type	UE	UF	VA	VC	VD	VE	W	WK	YF	YP	ZB	ZF
Type 10	Ø89.5	135	14	15	32	35	13	45	17	13	145	155
Type 20	Ø129	195	21	20	43	50	17	60	23	17	200	215
Type 30	Ø155	225	25	25	50	60	20	70	32	20	235	255
Type 40	Ø177	260	28	29	57	69	23	80	32	24	270	290
Type 50	Ø193	285	31	37	65	82	25	90	33	25	303	325

Dimensions-Rod Side Trunnion (TA)

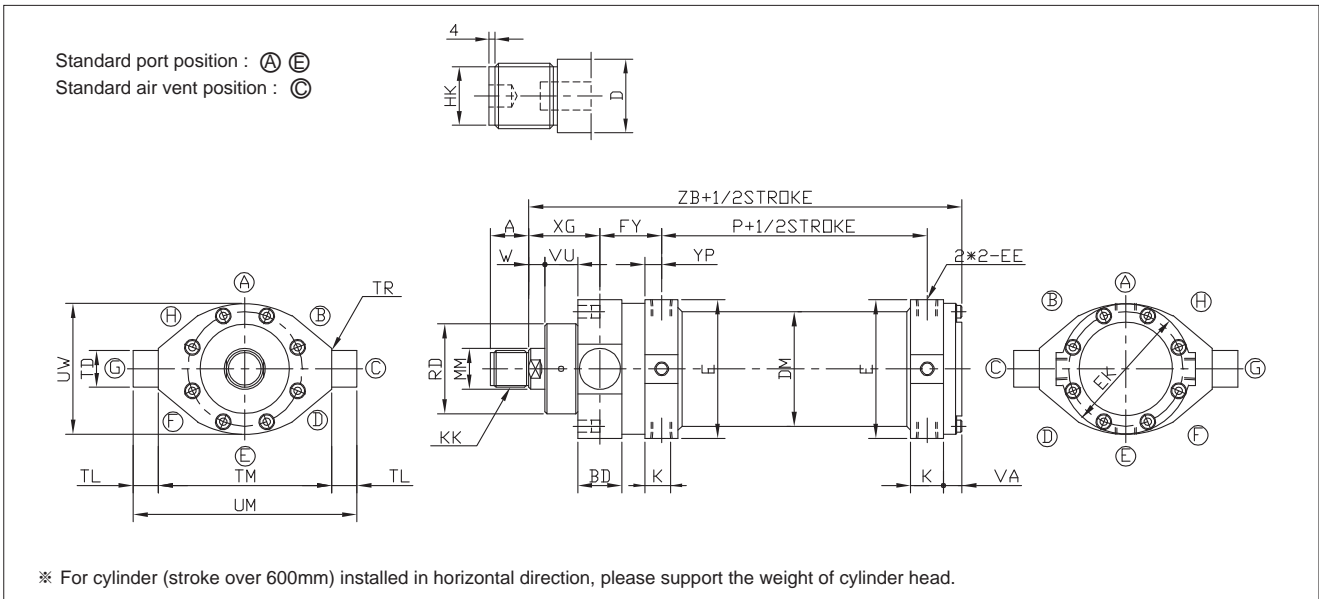

Dimensions-Head Side Trunnion (TB)

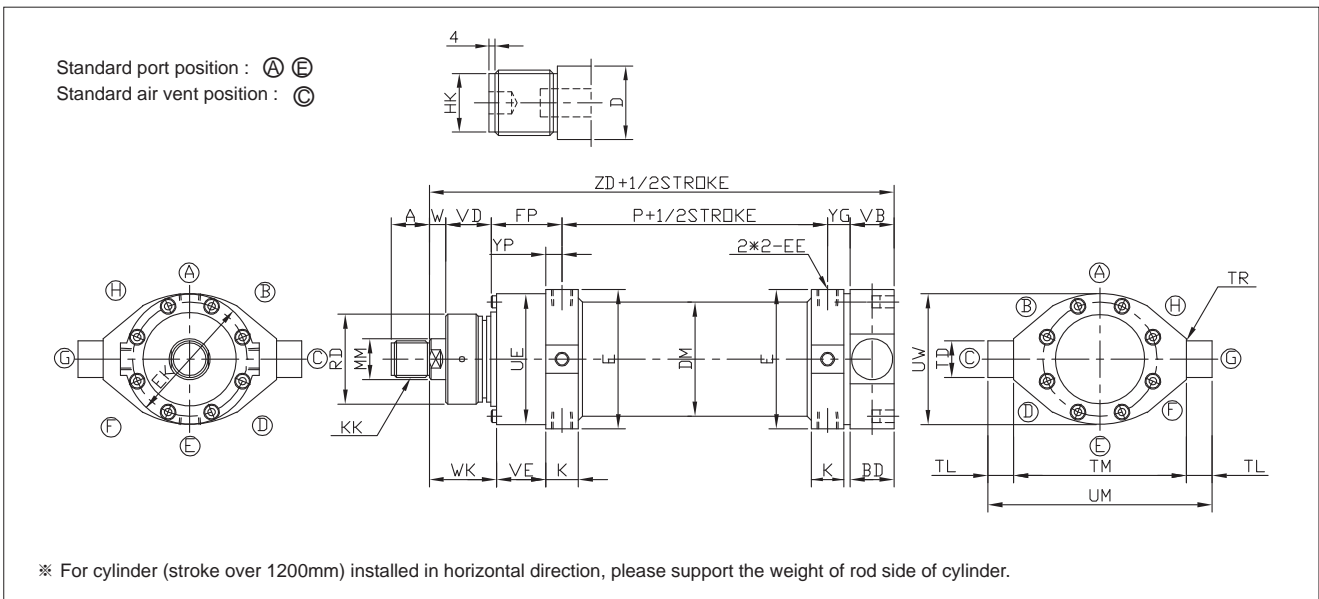

Unit : mm

Type	A	BD	D	DM	E	EE	EK	FY	FP	HK	K	KK	MM	P	RD	TD	TL
Type 10	25	31	24	∅73	98	Rc(PT)3/8	95	43	48	∅21 ^{H9}	26 ⁰ _{-0.1}	M24×2	∅27	25	∅59	∅28 ^{E9}	20
Type 20	35	38	32	∅105	138	Rc(PT)1/2	136	55	67	∅30 ^{H9}	34 ⁰ _{-0.1}	M33×2	∅38	35	∅84	∅35 ^{E9}	25
Type 30	40	48	41	∅125	158	Rc(PT)1/2	161	68	80	∅36 ^{H9}	42 ⁰ _{-0.1}	M39×2	∅45	40	∅100	∅45 ^{E9}	30
Type 40	45	58	46	∅145	178	Rc(PT)3/4	183	81	93	∅46 ^{H9}	47 ⁰ _{-0.1}	M45×2	∅52	45	∅112	∅55 ^{E9}	30
Type 50	52	63	55	∅165	196	Rc(PT)3/4	200	93	107	∅49 ^{H9}	48 ⁰ _{-0.1}	M52×2	∅59	50	∅128	∅60 ^{E9}	35

Type	TM	TR	UE	UM	UW	VA	VB	VD	VE	VU	W	WK	XC	XG	YG	YP	ZB	ZD
Type 10	100 ⁰ _{-0.35}	R3	∅89.5	140	95	14	16	32	35	21	13	45	150	50	32	13	145	166
Type 20	145 ⁰ _{-0.4}	R3	∅129	195	135	21	20	43	50	35	17	60	205	72	43	17	200	225
Type 30	175 ⁰ _{-0.4}	R3	∅155	235	160	25	25	50	60	37	20	70	240	82	50	20	235	265
Type 40	200 ⁰ _{-0.46}	R3	∅177	260	185	28	30	57	69	39	23	80	280	92	62	24	270	310
Type 50	220 ⁰ _{-0.46}	R3	∅193	290	205	31	32	65	82	47	25	90	315	104	68	25	303	347

Dimensions-Single Clevis (CA)

Standard port position : (A) (E)
Standard air vent position : (C)

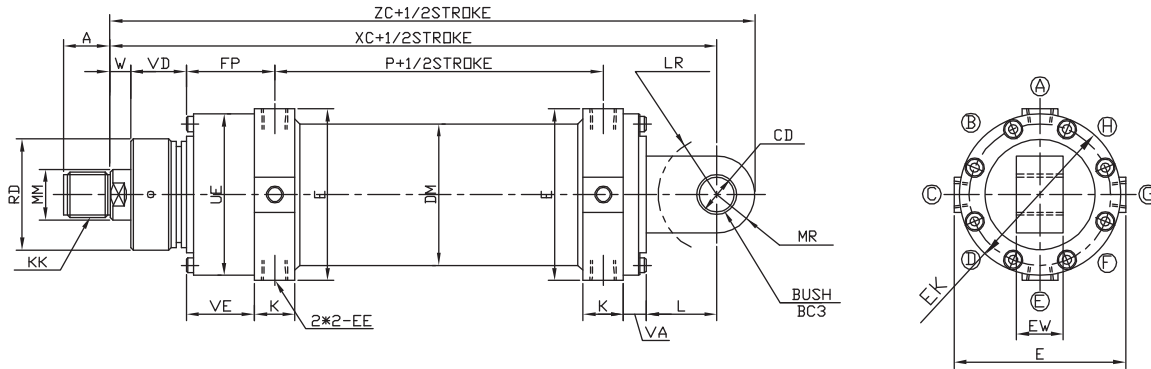
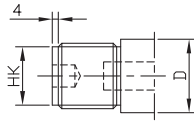

※ For cylinder (stroke over 1200mm) installed in horizontal direction, please support the weight of rod side of cylinder.

Unit : mm

Type	A	CD	D	DM	E	EE	EK	EW	FP	HK	K	KK	L	LR	MM	MR	P
Type 10	25	∅25 ^{H10}	24	∅73	98	Rc(PT)3/8	95	28 ⁰ _{-0.1}	48	∅21 ^{H9}	26 ⁰ _{-0.1}	M24x2	30	R29	∅27	R22	25
Type 20	35	∅35 ^{H10}	32	∅105	138	Rc(PT)1/2	136	40 ⁰ _{-0.1}	67	∅30 ^{H9}	34 ⁰ _{-0.1}	M33x2	45	R44	∅38	R30	35
Type 30	40	∅45 ^{H10}	41	∅125	158	Rc(PT)1/2	161	50 ⁰ _{-0.1}	80	∅36 ^{H9}	42 ⁰ _{-0.1}	M39x2	55	R54	∅45	R38	40
Type 40	45	∅55 ^{H10}	46	∅145	178	Rc(PT)3/4	183	55 ⁰ _{-0.1}	93	∅46 ^{H9}	47 ⁰ _{-0.1}	M45x2	65	R64	∅52	R45	45
Type 50	52	∅60 ^{H10}	55	∅165	196	Rc(PT)3/4	200	63 ⁰ _{-0.1}	107	∅49 ^{H9}	48 ⁰ _{-0.1}	M52x2	70	R69	∅59	R69	50

Type	RD	UE	VA	VD	VE	W	XC	ZC
Type 10	∅59	∅89.5	14	32	35	13	175	197
Type 20	∅84	∅129	21	43	50	17	245	275
Type 30	∅100	∅155	25	50	60	20	290	328
Type 40	∅112	∅177	28	57	69	23	335	380
Type 50	∅128	∅193	31	65	82	25	373	423

Hydraulic Cylinder
Reference Data
KP140H
KP210H
KPC70/140H
KPC210H
KTC70HP
KP140HS
KP125/160A
KP35R
KH

KP140HS series



KP140HS-SD80-S40



KP140HS-LA50-S30N

Features

- Compact hydraulic cylinder with steel tube.
- Double acting hydraulic cylinder for 140kgf/cm² with bore sizes from Ø20 to Ø125.
- Appropriate for pressing, clamping and short-stroke operations.
- Cylinder designed with a shorter length than a conventional cylinder.

Symbol



Double Acting / Single Rod

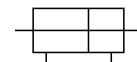

Double Acting / Double Rod

How to Order

KP140HS - SD 80 - S 40

①
 ②
 ③
 ④
 ⑤
 ⑥
 ⑦
 ⑧

① Series

Series	Type	Tube material	Operating pressure
KP140HS	Single rod	Steel	140 kgf/cm ²
KP140HS W	Double rod		
KP140HS HL	Auto switch attached type (Single rod)	SUS	
KP140HS HL W	Auto switch attached type (Double rod)		

⑤ Cylinder stroke

Bore size	Standard stroke	Max. stroke
Ø32	5, 10, 15, 20, 25, 30, 35, 40, 45, 50	50
Ø40		100
Ø50		
Ø63		
Ø80		
Ø100	-	-
Ø125	-	-

- * Check buckling, as it varies depending on mounting style.
- * Contact us for longer stroke.

② Seal material

Nil	Nitrile Urethane (Standard)
1	Nitrile rubber
2	FPM rubber

⑥ Rod end attachment

Nil	Rod end female thread (Standard)
N	Rod end male thread

③ Mounting style

SD	Standard
LA	Axial angle of foot

⑦ Auto switch

Reed A/S	Model	Solid state A/S	Model
Z72	D-Z72K	Y59A	D-Y59AK
Z73	D-Z73K	Y7PK	D-Y7PK
Z76	D-Z76K	Y59B	D-Y59BK
Z80	D-Z80K		
Z82	D-Z82K		

- * Only for auto switch attached type.
- * For more information, refer to Auto Switch Catalogue.

④ Bore size

32	Ø30
40	Ø40
50	Ø50
63	Ø63
80	Ø80
100	Ø100
125	Ø125

⑧ Number of auto switch

Nil	2 pcs
1	1 pc
N	N pcs (N:3,4,5...)

- * Only for auto switch attached type.



Specifications

Model	KP140HS
Bore size	Ø20, Ø25, Ø30, Ø40, Ø50, Ø63, Ø80
Max. operating pressure	140kgf/cm ² (14.0MPa)
Proof pressure	210kgf/cm ² (21.0MPa)
Min. operating pressure	3kgf/cm ² (0.3MPa)
Operating piston speed	10~300mm/sec
Ambient & fluid temperature	-10 ~ 70℃
Working oil	Petroleum-based fluid
Tolerance of thread	KS class 2
Tolerance of stroke	0~+0.8mm

※ Contact us for delivery of auto switch attached type.

Mass

KP140HS

Unit : kg

Bore size	Standard Type (SD)				Foot Type(LA)				Additional mass of male thread
	Double acting single rod		Double acting double rod		Double acting single rod		Double acting double rod		
	Basic mass	Additional mass per each 1mm of stroke	Basic mass	Additional mass per each 1mm of stroke	Basic mass	Additional mass per each 1mm of stroke	Basic mass	Additional mass per each 1mm of stroke	
Ø32	1.4	0.025	1.6	0.024	1.4	0.027	1.9	0.028	0.057
Ø40	1.8	0.030	2.1	0.032	1.8	0.034	2.4	0.036	0.114
Ø50	2.5	0.037	2.7	0.036	2.6	0.044	3.3	0.048	0.201
Ø63	3.8	0.047	4.1	0.041	4.1	0.062	5.0	0.068	0.435
Ø80	6.6	0.067	7.6	0.083	-	-	-	-	0.798
Ø100	12.5	0.102	14.9	0.121	-	-	-	-	-
Ø125	21.5	0.152	29	0.222	-	-	-	-	-

KP140HS HL

Unit : kg

Bore size	Standard Type (SD)				Foot Type(LA)		Additional mass of male thread
	Double acting single rod		Double acting double rod		Double acting single rod		
	Basic mass	Additional mass per each 1mm of stroke	Basic mass	Additional mass per each 1mm of stroke	Basic mass	Additional mass per each 1mm of stroke	
Ø32	1.2	0.022	1.3	0.024	1.2	0.022	0.057
Ø40	1.6	0.028	1.7	0.031	1.6	0.028	0.114
Ø50	2.2	0.036	2.4	0.041	2.3	0.036	0.201
Ø63	3.3	0.049	3.7	0.057	3.6	0.049	0.435
Ø80	6.2	0.071	7.2	0.084	-	-	0.0798

Calculation:

Ex) KP140HS-SD40-S50
 Basic mass: 1.8
 Additional mass: 0.030
 Cylinder stroke: 50mm
 $1.8 + (0.030 \times 50) = 3.3\text{kg}$

Hydraulic Cylinder

Reference Data

KP140H

KP210H

KPC70/140H

KPC210H

KTC70HP

KP140HS

KP125/160A

KP35R

KH

Structure

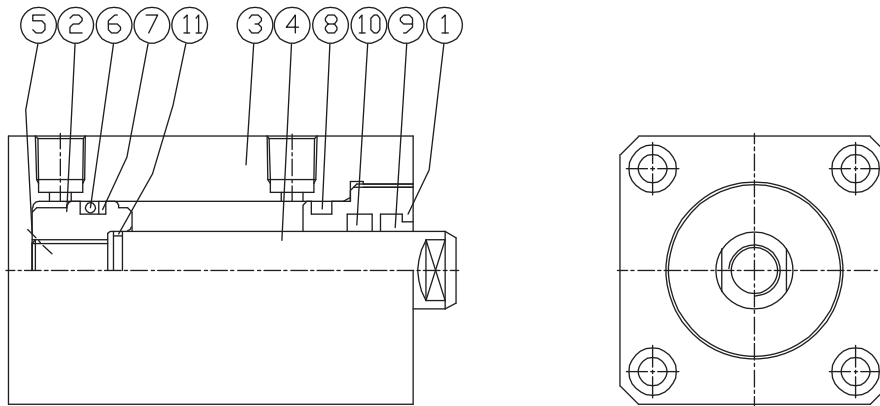

Part List

Part no.	Parts	Material
1	Rod Cover	GC200
2	Piston	GC200
3	Cylinder Tube	SM45C
4	Piston Rod	SM45C
5	Set Bolt	SCM430

Packing List

Part no.	6	7	8	9	10	11
Parts	Piston Packing	B.U.R	Tube O-Ring	Dust Seal	Rod Packing	Rod O-Ring
Material	NBR	PTFT	NBR	NBR	NBR	NBR
Bore size	Type	Type	Type	Type	Type	Type
Ø20	P16	For P16	S18	LBH12	USH12	P8
Ø25	P21	For P21	S22	LBH14	USH14	P10
Ø32	P26	For P26	S29	LBH18	USH18	S16
Ø40	P34	For P34	S35	LBH22	USH22	S20
Ø50	P44	For P44	S45	LBH28	USH28	S25
Ø63	P53	For P53	S58	LBH35	USH35	S32
Ø80	P70	For P70	S75	LBH45	USH45	S42
Ø100	P90	For P90	S95	LBH56	USH56	G40
Ø125	P115	For P115	S120	LBH35	USH35	G50

Dimensions-(SD, LA)

SD type

Bore size Ø32, Ø40, Ø50, Ø63, Ø80, Ø100, Ø125

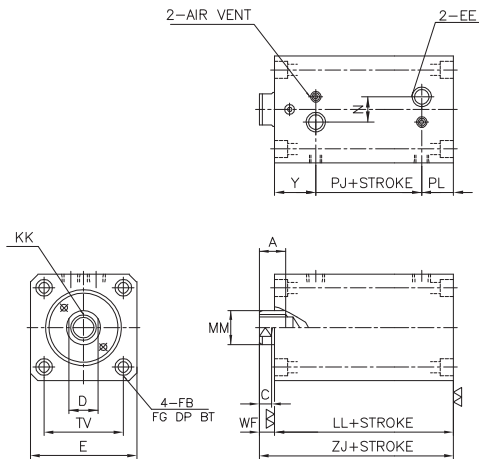

LA type

Bore size Ø32, Ø40, Ø50, Ø63

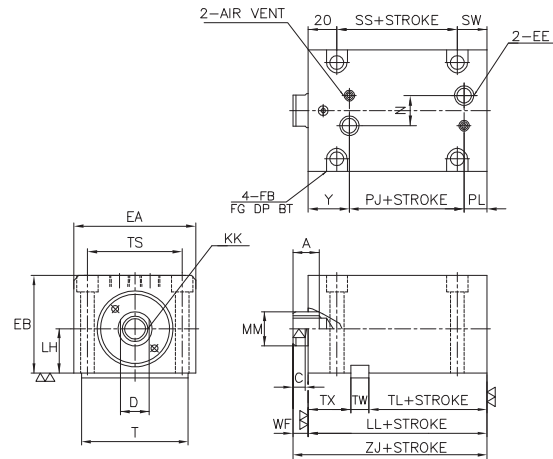

Hydraulic Cylinder

Reference Data

KP140H

KP210H

KPC70/140H

KPC210H

KTC70HP

KP140HS

KP125/160A

KP35R

KH

Unit : mm

Bore size	A	BT		C	D	E	EA	EB	EE	FB		FG		KK	LH	LL
		SD type	LA type							SD type	LA type	SD type	LA type			
Ø32	15	6.5	8.6	7	14	□62	70	56	Rc(PT)1/4	Ø6.8	Ø9	Ø11	Ø14	M12x1.75	25 ^{+0.06}	54
Ø40	20	8.6	10.8	7	19	□70	80	64	Rc(PT)1/4	Ø9	Ø11	Ø14	Ø17.5	M16x2.0	29 ^{+0.06}	55
Ø50	24	10.8	14	8	25	□80	94	74	Rc(PT)1/4	Ø11	Ø14	Ø17.5	Ø20	M20x2.5	34 ^{+0.06}	60
Ø63	33	13	15.2	10	31	□94	114	89	Rc(PT)1/4	Ø14	Ø16	Ø20	Ø23	M27x3.0	42 ^{+0.06}	67
Ø80	33	15.2	-	14	41	□114	-	-	Rc(PT)3/8	Ø16	-	Ø23	-	M30x3.5	-	78
Ø100	45	21.5	-	20	50	□145	-	-	Rc(PT)3/8	Ø22	-	Ø32	-	M39x4.0	-	95
Ø125	50	25.5	-	25	65	□185	-	-	Rc(PT)1/2	Ø26	-	Ø39	-	M42x4.5	-	105

Bore size	MM	N	PJ	PL	SS	SW	T	TL	TS	TV	TW	TX	WF	Y	ZJ
Ø32	Ø18	20	14	12	24	10	63	14	56	□47	12	28	10	28	64
Ø40	Ø22	20	16	12	23	12	70	15	62	□52	12	28	10	27	65
Ø50	Ø28	20	19	13	27	13	80	17	74	□58	14	29	11	28	71
Ø63	Ø35	20	24	13	32	15	100	20	90	□69	16	31	13	33	80
Ø80	Ø45	30	25	18	-	-	-	-	-	□86	-	-	17	35	95
Ø100	Ø56	36	39	21	-	-	-	-	-	□105	-	-	26(36)	35	121(131)
Ø125	Ø71	56	44	26	-	-	-	-	-	□140	-	-	31	35	136

Dimensions-Single Rod Male Thread Standard Type, Axial Angle of Foot (SD, LA)

SD type

Bore size Ø32, Ø40, Ø50, Ø63, Ø80, Ø100, Ø125

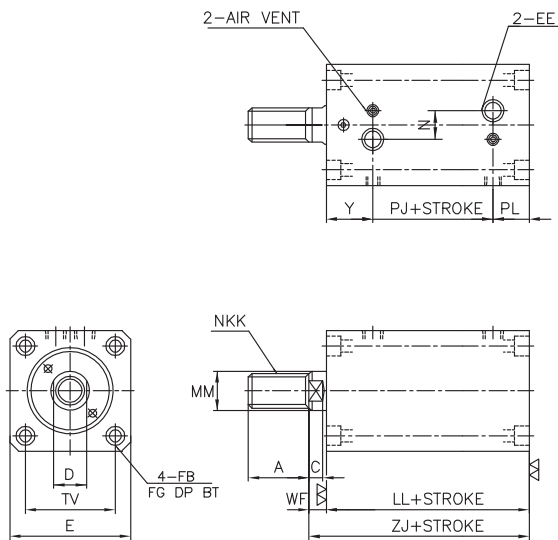

LA type

Bore size Ø32, Ø40, Ø50, Ø63

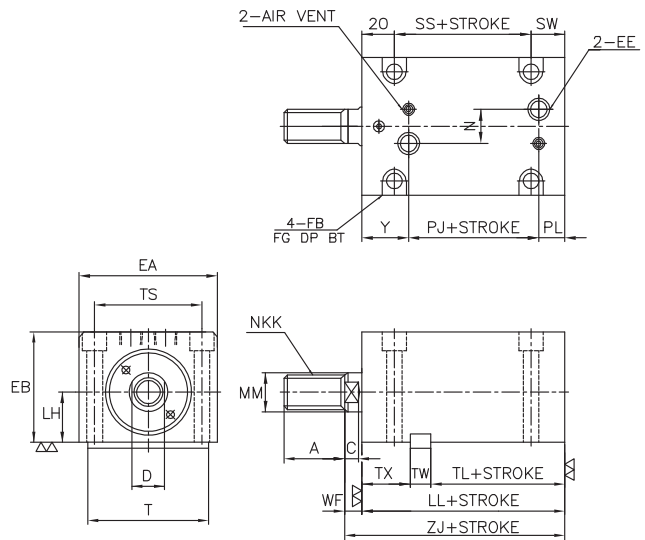

Unit : mm

Bore size	A	BT		C	D	E	EA	EB	EE	FB		FG		NKK	LH	LL
		SD type	LA type							SD type	LA type	SD type	LA type			
Ø32	25	6.5	8.6	7	16	□62	70	56	Rc(PT)1/4	Ø6.8	Ø9	Ø11	Ø14	M16x1.5	25 ^{±0.06}	54
Ø40	20	8.6	10.8	7	20	□70	80	64	Rc(PT)1/4	Ø9	Ø11	Ø14	Ø17.5	M20x1.5	29 ^{±0.06}	55
Ø50	35	10.8	13	8	25	□80	94	74	Rc(PT)1/4	Ø11	Ø14	Ø17.5	Ø20	M24x1.5	34 ^{±0.06}	60
Ø63	35	13	15.2	9	31	□94	114	89	Rc(PT)1/4	Ø14	Ø16	Ø20	Ø23	M30x1.5	42 ^{±0.06}	67
Ø80	60	15.2	-	14	41	□114	-	-	Rc(PT)3/8	Ø16	-	Ø23	-	M39x1.5	-	78
Ø100	75	21.5	-	20	50	□145	-	-	Rc(PT)3/8	Ø22	-	Ø32	-	M48x1.5	-	95
Ø125	95	25.5	-	25	65	□185	-	-	Rc(PT)1/2	Ø26	-	Ø39	-	M64x2.0	-	105

Bore size	MM	N	PJ	PL	SS	SW	T	TL	TS	TV	TW	TX	WF	Y	ZJ
Ø32	Ø18	20	14	12	24	10	63	14	56	□47	12	28	10	28	64
Ø40	Ø22	20	16	12	23	12	70	15	62	□52	12	28	10	27	65
Ø50	Ø28	20	19	13	27	13	80	17	74	□58	14	29	11	28	71
Ø63	Ø35	20	24	13	32	15	100	20	90	□69	16	31	13	33	80
Ø80	Ø45	30	25	18	-	-	-	-	-	□86	-	-	17	35	95
Ø100	Ø56	0	39	21	-	-	-	-	-	□105	-	-	26	35	121
Ø125	Ø71	0	44	26	-	-	-	-	-	□140	-	-	31	35	136

Dimensions-Double Rod Female Thread Standard Type, Axial Angle of Foot (SD, LA)

SD type

Bore size Ø32, Ø40, Ø50, Ø63, Ø80, Ø100, Ø125

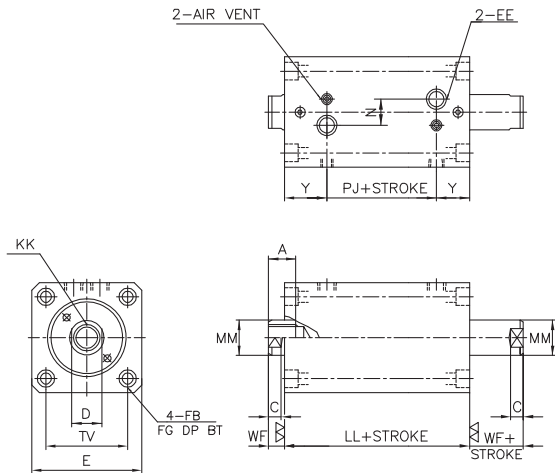

LA type

Bore size Ø32, Ø40, Ø50, Ø63

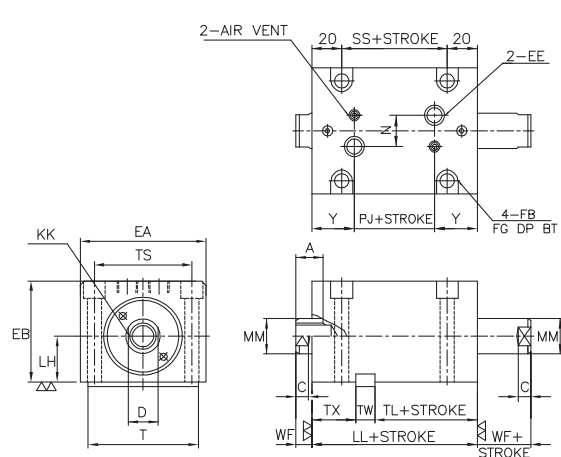

Hydraulic Cylinder

Reference Data

KP140H

KP210H

KPC70/140H

KPC210H

KTC70HP

KP140HS

KP125/160A

KP35R

KH

Unit : mm

Bore size	A	BT		C	D	E	EA	EB	EE	FB		FG		KK	LH	LL
		SD type	LA type							SD type	LA type	SD type	LA type			
Ø32	15	6.5	8.6	7	14	□62	70	56	Rc(PT)1/4	Ø6.8	Ø9	Ø11	Ø14	M12x1.75	25 ^{+0.06}	72
Ø40	20	8.6	10.8	7	19	□70	80	64	Rc(PT)1/4	Ø9	Ø11	Ø14	Ø17.5	M16x2	29 ^{+0.06}	72
Ø50	24	10.8	14	8	25	□80	94	74	Rc(PT)1/4	Ø11	Ø14	Ø17.5	Ø20	M20x2.5	34 ^{+0.06}	75
Ø63	33	13	15.2	10	31	□94	114	89	Rc(PT)1/4	Ø14	Ø16	Ø20	Ø23	M27x3	42 ^{+0.06}	82
Ø80	33	15.2	-	14	41	□114	-	-	Rc(PT)3/8	Ø16	-	Ø23	-	M30x3.5	-	95
Ø100	45	21.5	-	20	50	□145	-	-	Rc(PT)3/8	Ø22	-	Ø32	-	M39x4.0	-	112
Ø125	50	25.5	-	25	65	□185	-	-	Rc(PT)1/2	Ø26	-	Ø39	-	M42x4.5	-	117

Bore size	MM	N	PJ	SS	T	TL	TS	TV	TW	TX	WF	Y
Ø40	Ø22	20	18	32	70	32	62	□52	12	28	10	27
Ø50	Ø28	20	19	35	80	32	74	□58	14	29	11	28
Ø63	Ø35	20	22	42	100	35	90	□69	16	31	13	33
Ø80	Ø45	30	25	-	-	-	-	□86	-	-	17	35
Ø100	Ø56	0	42	-	-	-	-	□105	-	-	26	35
Ø125	Ø71	0	47	-	-	-	-	□140	-	-	31	35

Dimensions-Double Rod Male Thread Standard Type, Axial Angle of Foot (SD, LA)

SD type / Bore size Ø32, Ø40, Ø50, Ø63, Ø80, Ø100, Ø125

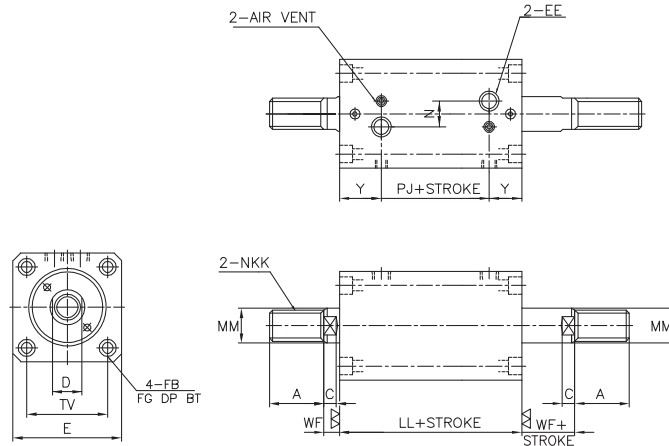

LA type / Bore size Ø32, Ø40, Ø50, Ø63

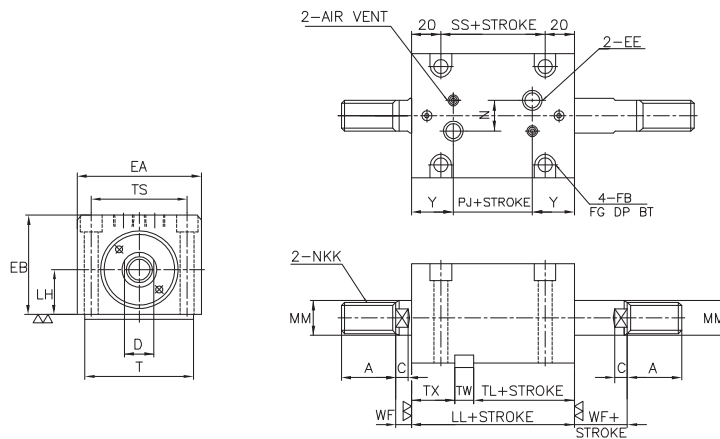

Unit : mm

Bore size	A	BT		C	D	E	EA	EB	EE	FB		FG		NKK	LH	LL
		SD type	LA type							SD type	LA type	SD type	LA type			
Ø32	25	6.5	8.6	7	16	□62	70	56	Rc(PT)1/4	Ø6.8	Ø9	Ø11	Ø14	M16x1.5	25 ^{+0.06}	72
Ø40	20	8.6	10.8	7	20	□70	80	64	Rc(PT)1/4	Ø9	Ø11	Ø14	Ø17.5	M20x1.5	29 ^{+0.06}	72
Ø50	35	10.8	13	8	25	□80	94	74	Rc(PT)1/4	Ø11	Ø14	Ø17.5	Ø20	M24x1.5	34 ^{+0.06}	75
Ø63	35	13	15.2	9	31	□94	114	89	Rc(PT)1/4	Ø14	Ø16	Ø20	Ø23	M30x1.5	42 ^{+0.06}	82
Ø80	60	15.2	-	14	41	□114	-	-	Rc(PT)3/8	Ø16	-	Ø23	-	M39x1.5	-	95
Ø100	75	21.5	-	20	50	□145	-	-	Rc(PT)3/8	Ø22	-	Ø32	-	M48x1.5	-	112
Ø125	95	25.5	-	25	65	□185	-	-	Rc(PT)1/2	Ø26	-	Ø39	-	M64x2.0	-	117

Bore size	MM	N	PJ	SS	T	TL	TS	TV	TW	TX	WF	Y
Ø40	Ø22	20	18	32	70	32	62	□52	12	28	10	27
Ø50	Ø28	20	19	35	80	32	74	□58	14	29	11	28
Ø63	Ø35	20	22	42	100	35	90	□69	16	31	13	33
Ø80	Ø45	30	25	-	-	-	-	□86	-	-	17	35
Ø100	Ø56	0	42	-	-	-	-	□105	-	-	26	35
Ø125	Ø71	0	47	-	-	-	-	□140	-	-	31	35

KP125/160A series



KP125A-H SD63-S20

Features

- Compact hydraulic cylinder with Aluminium tube.
- Double acting hydraulic cylinder for 125kgf/cm² or 160kgf/cm² with a bore from Ø20 to Ø80.
- Easy to equip with auto switch.
- Excellent appearance and identical dimensions as KP140HS.

Symbol

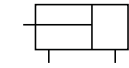

Double Acting / Single Rod

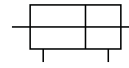

Double Acting / Double Rod

Hydraulic Cylinder

Reference Data

KP140H

KP210H

KPC70/140H

KPC210H

KTC70HP

KP140HS

KP125/160A

KP35R

KH

How to Order

① **KP125A** - ② ③ **H** ④ **SD** ⑤ **63** - ⑥ **S** ⑦ **20** ⑧

① Series

KP125A	Single rod	125kgf/cm ²
KP125A W	Double rod	125kgf/cm ²
KP160A	Single rod (High pressure)	160kgf/cm ²

※ Double rod type is not available for KP160A series.

② Seal material

Nil	Nitrile Urethane (Standard)
2	Urethane rubber

③ Magnet

Nil	Without magnet
H	With built-in magnet

※ Cylinder with built-in magnet and without built-in magnet have the same dimensions.

④ Bore size

20	Ø20
25	Ø25
32	Ø32
40	Ø40
50	Ø50
63	Ø63
80	Ø80

⑤ Cylinder stroke

Bore size	Standard stroke	Max. stroke
Ø20	10, 15, 20, 25, 30, 40, 50	50
Ø25		
Ø32		
Ø40		
Ø50		
Ø63	100	
Ø80		-

※ Check buckling, as it varies depending on mounting style.

※ Contact us for longer stroke.

⑥ Rod end thread

Nil	Female thread (Standard)
N	Male thread

⑦ Auto switch

Reed A/S	Model	Solid state A/S	Model
Z72	D-Z72K	Y59A	D-Y59AK
Z73	D-Z73K	Y7PK	D-Y7PK
Z76	D-Z76K	Y59B	D-Y59BK
Z80	D-Z80K		
Z82	D-Z82K		

※ Only for auto switch attached type.

※ For more information, refer to Auto Switch Catalogue.

⑧ Number of auto switches

Nil	2 pcs
1	1 pc
N	N pcs (N:3,4,5...)

※ Only for auto switch attached type.

Specifications

Type	KP125A	KP160A
Bore size	Ø20, Ø25, Ø32, Ø40, Ø50, Ø63, Ø80	
Max. operating pressure	125kgf/cm ² (12.5MPa)	160kgf/cm ² (16.0MPa)
Proof pressure	188kgf/cm ² (18.8MPa)	240kgf/cm ² (24.0MPa)
Min. operating pressure	3kgf/cm ² (0.3MPa)	
Operating piston speed	8~10mm/s	
Ambient & fluid temperature	-10 ~ 70°C	
Working oil	Petroleum-based fluid	
Tolerance of thread	KS class 2	
Tolerance of stroke	0~+0.8mm	

Mass

Double Acting Single Rod Type

Unit : kg

Type	Bore size	Stroke(mm)										Additional mass of male thread
		5	10	15	20	25	30	35	40	45	50	
Standard type	Ø20	0.29	0.28	0.30	0.32	0.35	0.37	0.39	0.41	0.43	0.45	0.02
	Ø25	0.41	0.40	0.43	0.45	0.48	0.51	0.54	0.56	0.59	0.62	0.03
	Ø32	0.68	0.72	0.77	0.81	0.86	0.90	0.94	0.99	1.03	1.08	0.05
	Ø40	0.90	0.95	1.01	1.07	1.12	1.18	1.24	1.29	1.35	1.41	0.10
	Ø50	1.35	1.43	1.50	1.58	1.65	1.73	1.81	1.88	1.96	2.03	0.18
	Ø63	2.10	2.21	2.31	2.42	2.52	2.63	2.74	2.84	2.95	3.05	0.40
	Ø80	3.87	4.02	4.18	4.34	4.49	4.65	4.81	4.96	5.12	5.28	0.76
With auto switch	Ø20	0.30	0.29	0.31	0.33	0.36	0.38	0.40	0.42	0.44	0.46	0.02
	Ø25	0.42	0.41	0.44	0.46	0.49	0.52	0.55	0.57	0.60	0.63	0.03
	Ø32	0.70	0.75	0.80	0.84	0.89	0.93	0.98	1.02	1.07	1.11	0.05
	Ø40	0.93	0.99	1.05	1.11	1.16	1.22	1.28	1.33	1.39	1.45	0.10
	Ø50	1.14	1.49	1.57	1.64	1.72	1.79	1.87	1.94	2.02	2.09	0.18
	Ø63	2.20	2.30	2.40	2.51	2.61	2.72	2.82	2.93	3.03	3.14	0.40
	Ø80	3.98	4.13	4.28	4.44	4.60	4.75	4.91	5.07	5.22	5.38	0.76

Double Acting Double Rod Type

Unit : kg

Type	Bore size	Stroke(mm)										Additional mass of male thread
		5	10	15	20	25	30	35	40	45	50	
Standard type	Ø20	0.40	0.40	0.43	0.45	0.48	0.50	0.53	0.55	0.58	0.60	0.04
	Ø25	0.57	0.56	0.59	0.62	0.65	0.70	0.72	0.75	0.78	0.81	0.06
	Ø32	1.06	1.11	1.17	1.22	1.28	1.33	1.39	1.44	1.50	1.55	0.10
	Ø40	1.37	1.44	1.51	1.58	1.65	1.72	1.79	1.86	1.93	2.00	0.20
	Ø50	2.00	2.09	2.19	2.29	2.39	2.49	2.59	2.69	2.79	2.89	0.36
	Ø63	3.03	3.17	3.32	3.46	3.61	3.75	3.90	4.04	4.19	4.33	0.80
	Ø80	5.58	5.79	6.01	6.23	6.44	6.66	6.88	7.09	7.31	7.53	1.52
With auto switch	Ø20	0.40	0.41	0.44	0.46	0.48	0.51	0.53	0.56	0.58	0.61	0.04
	Ø25	0.58	0.56	0.60	0.63	0.66	0.69	0.72	0.76	0.79	0.82	0.06
	Ø32	1.09	1.14	1.19	1.25	1.30	1.36	1.41	1.47	1.52	1.58	0.10
	Ø40	1.39	1.46	1.53	1.60	1.67	1.74	1.81	1.88	1.95	2.02	0.20
	Ø50	2.02	2.12	2.22	2.32	2.42	2.52	2.61	2.71	2.81	2.91	0.36
	Ø63	3.05	3.20	3.34	3.49	3.63	3.78	3.92	4.07	4.21	4.35	0.80
	Ø80	5.60	5.82	6.03	6.25	6.47	6.69	6.90	7.12	7.34	7.55	1.52

Structure

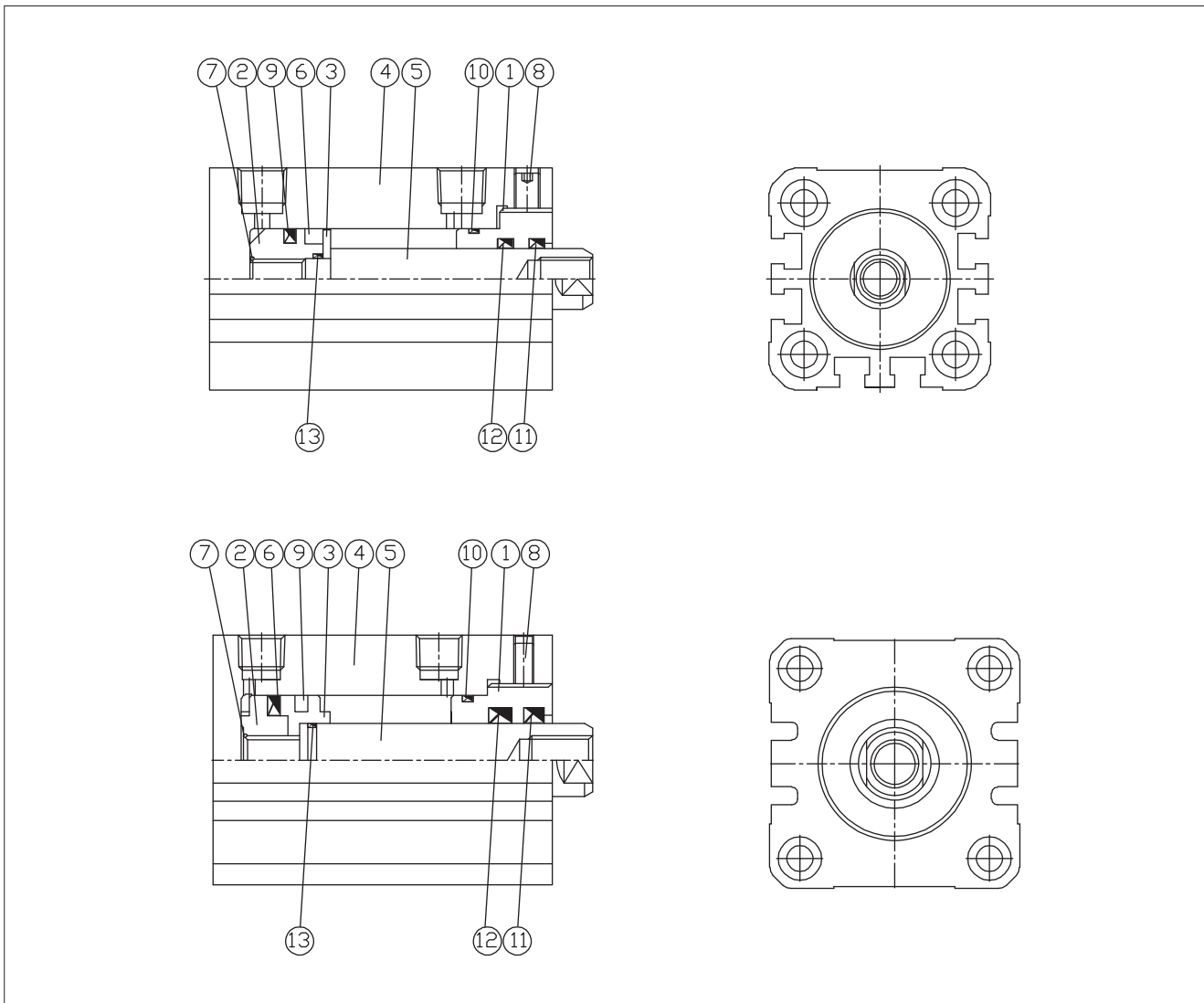

Hydraulic Cylinder
Reference Data
KP140H
KP210H
KPC70/140H
KPC210H
KTC70HP
KP140HS
KP125/160A
KP35R
KH

Part List

Part no.	Parts	Material	Remark
1	Rod Cover	Special Copper Alloy	-
2	Piston	Special Copper Alloy	-
3	Piston Holder	Stainless Steel, Special Copper Alloy	Ø20~Ø25 Ø32~Ø63
4	Cylinder Tube	Special Aluminium Alloy	-
5	Piston Rod	Stainless Steel, Carbon Steel	-
6	Magnet	-	-
7	Steel Ball	Stainless Steel	-
8	Set Bolt	SCM440	-

Packing List

Part no.	9	10	11	12	13	
Parts	Piston Packing	Tube O-Ring	Dust Seal	Rod Packing	Rod O-Ring	
Material	NBR	NBR	NBR	NBR	NBR	
Bore size	Type	Type	Type	Type	Type	
	Ø20	HSD20	BS18	SER12	NMY12	BS8
	Ø25	HSD25	BS22.4	SER14	NMY14	BS10
	Ø32	HSD32	BS29	LBH18	USH18/NMY18	BS12.5
	Ø40	HSD40	BG35	LBH22	USH22	BS18
	Ø50	HSD50	BG45	LBH28	USH28	BS24
	Ø63	HSD63	BG58	LBH35	USH35	BS28
Ø80	HSD80	BG75	LBH45	USH45	BS36	

Dimensions-KP125A (SD, W)

Single Rod (Female thread)
Bore size Ø20 ~ Ø80

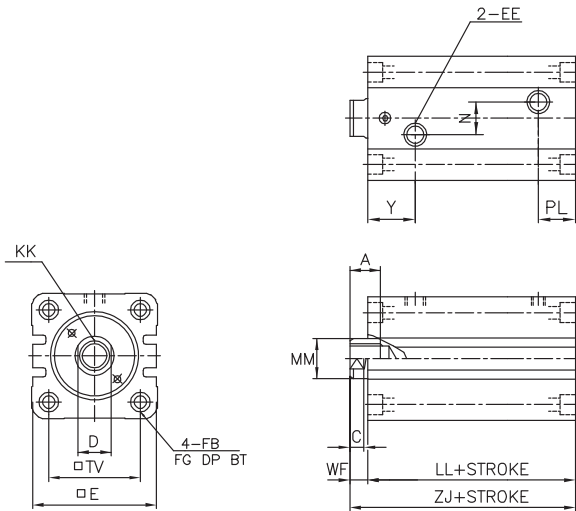

Double Rod (Female thread)
Bore size Ø20 ~ Ø80

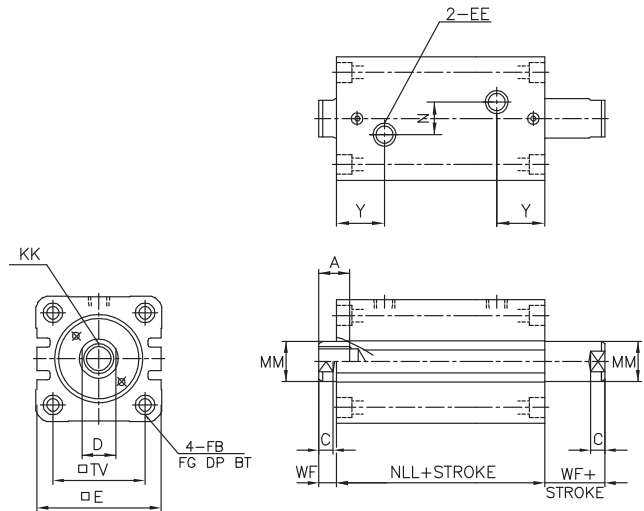

Single Rod (Male thread)
Bore size Ø20 ~ Ø80

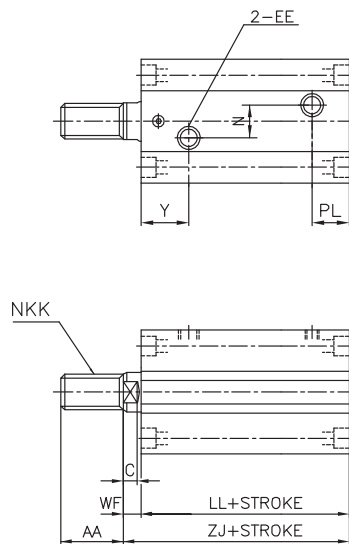

Double Rod (Male thread)
Bore size Ø20 ~ Ø80

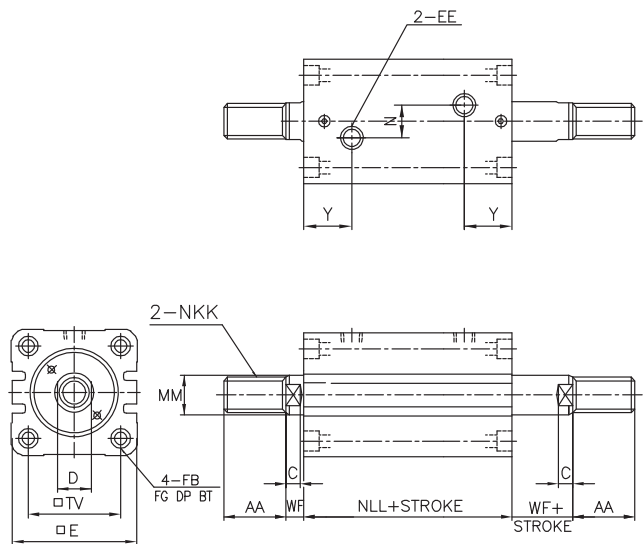

Unit : mm

Bore size	A	AA	BT	C	D	□E	EE	FB	FG	KK	LL	N	PL	NLL	MM	NKK	□TV	WF	Y	ZJ
Ø20	10	15	5.4	6	10	□44	Rc(PT)1/8	Ø5.5	Ø9.5	M8x1.25	43	6	10.5	54	Ø12	M10x1.25	□30	8	18	51
Ø25	12	18	5.4	6	12	□50	Rc(PT)1/8	Ø5.5	Ø9.5	M10x1.5	45	12	12	56	Ø14	M12x1.25	□36	8	20.5	53
Ø32	15	20	6.5	7	14	□62	Rc(PT)1/4	Ø6.6	Ø11	M12x1.75	54	20	12	72	Ø18	M16x1.5	□47	10	28	64
Ø40	20	20	8.6	7	19	□70	Rc(PT)1/4	Ø9	Ø14	M16x2	55	20	12	72	Ø22	M20x1.5	□52	10	27	65
Ø50	24	35	10.8	8	24	□80	Rc(PT)1/4	Ø11	Ø17.5	M20x2.5	60	20	12.5	75	Ø28	M24x1.5	□58	11	28	71
Ø63	33	45	13	9	30	□94	Rc(PT)1/4	Ø14	Ø20	M27x3	67	20	13	82	Ø35	M30x1.5	□69	13	30	80
Ø80	36	60	15.2	14	41	□114	Rc(PT)3/8	Ø16	Ø23	M30x3.5	78	30	18	95	Ø45	M39x1.5	□86	17	35	95

Dimensions-KP160A (Operating Pressure: 160kgf/cm²)

Single Rod (Female thread)
Bore size Ø20 ~ Ø80

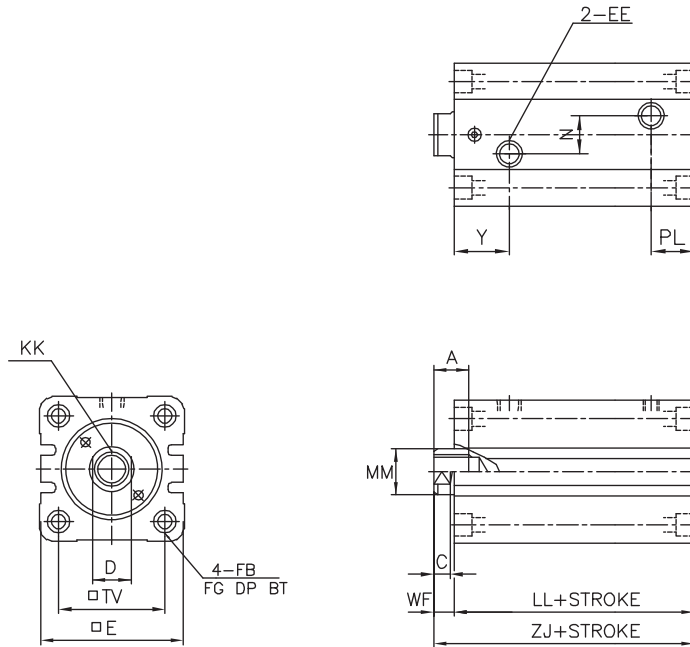

Single Rod (Male thread)
Bore size Ø20 ~ Ø80

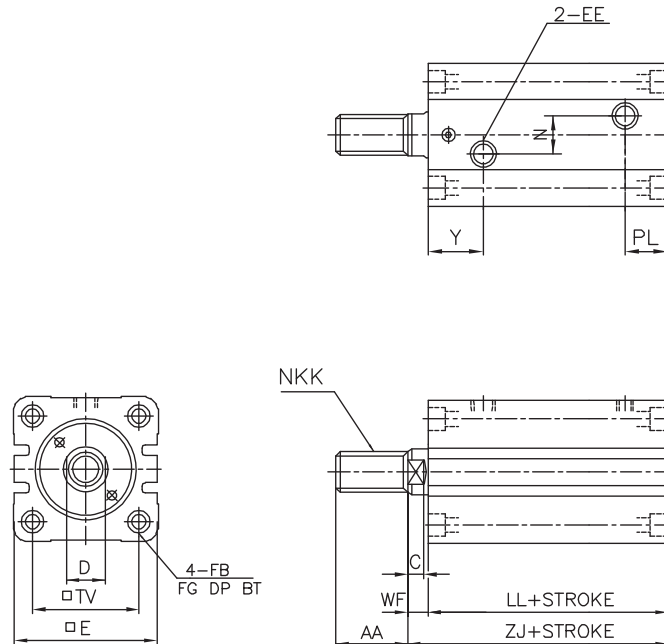

Hydraulic Cylinder
Reference Data
KP140H
KP210H
KPC70/140H
KPC210H
KTC70HP
KP140HS
KP125/160A
KP35R
KH

Unit : mm

Bore size	A	AA	BT	C	D	□E	EE	FB	FG	KK	LL	N	PL	MM	NKK	□TV	WF	Y	ZJ
Ø20	10	15	5.4	6	10	□44	Rc(PT)1/8	Ø5.5	Ø9.5	M8x1.25	43	6	10.5	Ø12	M10x1.25	□30	8	18	51
Ø25	12	18	5.4	6	12	□50	Rc(PT)1/8	Ø5.5	Ø9.5	M10x1.5	45	12	12	Ø14	M12x1.25	□36	8	20.5	53
Ø32	15	20	6.5	7	14	□62	Rc(PT)1/4	Ø6.6	Ø11	M12x1.75	58	20	12	Ø18	M16x1.5	□47	10	26.5	68
Ø40	20	20	8.6	7	19	□70	Rc(PT)1/4	Ø9	Ø14	M16x2	65	20	15	Ø22	M20x1.5	□52	10	30	75
Ø50	24	35	10.8	8	24	□80	Rc(PT)1/4	Ø11	Ø17.5	M20x2.5	70	20	16.5	Ø28	M24x1.5	□58	11	34	81
Ø63	33	45	13	9	30	□94	Rc(PT)1/4	Ø14	Ø20	M27x3	77	20	18	Ø35	M30x1.5	□69	13	35	90
Ø80	36	60	15.2	14	41	□114	Rc(PT)3/8	Ø16	Ø23	M30x3.5	88	30	25.5	Ø45	M39x1.5	□86	17	35	105

KP35R series



Features

- Rack-and-pinion rotary cylinder.
- Rotary cylinder for 35kgf/cm² with bore sizes from Ø30 to Ø80.
- The rotating angle can be adjusted with a range of ±5°
- Various mounting styles available. (SD, FA, FB)

Symbol



How to Order

KP35R - **1** **FA** **40** - **90** **A** **B**

① ② ③ ④ ⑤ ⑥ ⑦

① Series

KP35R	Rotary cylinder (35kgf/cm ²)
-------	--

④ Bore size

30	Ø30
40	Ø40
50	Ø50
63	Ø63
80	Ø80

⑦ Cushion valve position

B	Standard
A,C,D	Refer to figure below

② Type

1	Standard
2	With magnet

⑤ Rotating angle

90	90°
180	180°

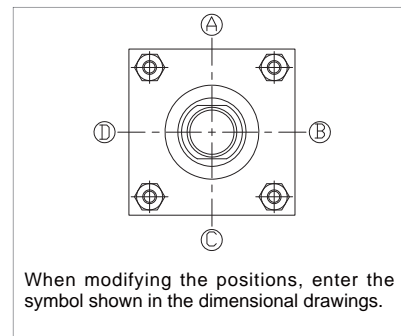

③ Mounting style

SD	Standard
FA	Top flange
FB	Bottom flange

⑥ Port position

A	Standard
B,C,D	Refer to figure below

Specifications

Type	KP35R
Bore size	Ø30, Ø40, Ø50, Ø63, Ø80
Variation	Rack and pinion type
Rotating angle	90°, 180°
Angle adjustment	±5°
Rated torque (at 35kgf/cm ²)	Ø30:60N·m, Ø40:106N·m, Ø50:220N·m, Ø63:436N·m, Ø80:840N·m,
Max. operating pressure	35kgf/cm ² (3.5MPa)
Proof pressure	50kgf/cm ² (5MPa)
Min. operating pressure	5kgf/cm ² (0.5MPa)
Ambient & fluid temperature	10 ~ 60°C
Working oil	Petroleum-based fluid
Tolerance of thread	KS class 2
Mounting style	SD, FA, FB

Volume of Fluid Required for Rotation

Unit : ml

Rotating angle / Bore size (mm)	90°	180°
Ø30	28.3	53.4
Ø40	51.9	99.5
Ø50	104.3	202.6
Ø63	203.8	399.9
Ø80	410.5	788.3

Precautions

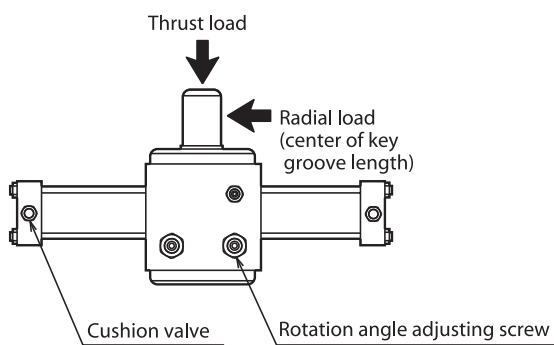

Allowable Radial and Thrust Loads

Load(kgf)	Radial Load	Thrust Load
Ø30	70	40
Ø40	145	80
Ø50	190	110
Ø63	250	150
Ø80	300	180

- ※ Avoid from applying a greater load (than those listed above) directly to the shaft.
- ※ At the rotating end of the rotary actuator, bring the shaft into contact with the rotation angle adjusting screw under the condition of sufficient cushioning effect. If the cushion is not effective, the rotation angle adjusting screw may be damaged.

Mass

Unit : kg

Bore size	Basic mass(SD)	Mounting mass
	Standard	FA, FB
Ø30-90°	5.0	0.94
Ø30-180°	5.2	
Ø40-90°	8.8	1.57
Ø40-180°	9.2	
Ø50-90°	13.9	2.09
Ø50-180°	14.7	
Ø63-90°	24.2	3.56
Ø63-180°	25.8	
Ø80-90°	41.0	6.54
Ø80-180°	44.1	

Calculation:

Ex.) KP35R-1 FA40-180A B
Basic mass: 9.2
FA mounting: 1.57
9.2 + 1.57 = 10.77kg

Theoretical Output Torque Charts

Bore size Ø32, Ø40, Ø50

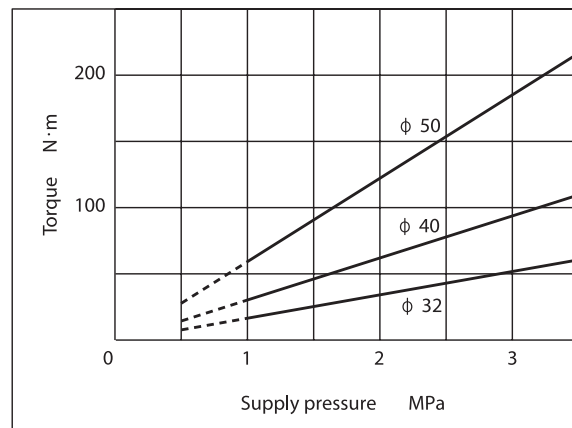

Bore size Ø63, Ø80

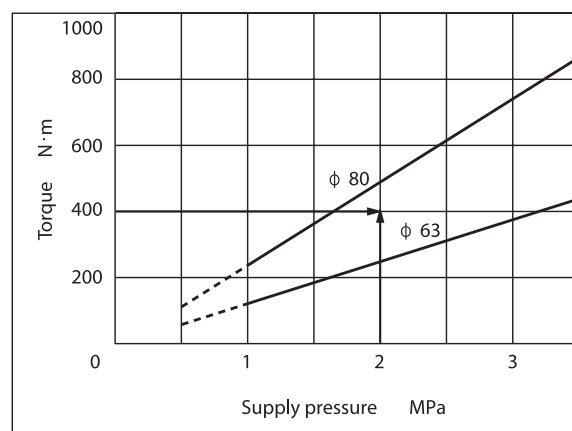

※ 1MPa=10.2kgf/cm², 100N·m=10.2kgf·m

How to Read the Graph

When a torque of 400N·m is required at a working pressure of 2MPa, determine the intersection of the lines extended from the vertical axis of supply pressure and the horizontal axis of torque. Find the bore above this intersection, and the bore of 80mm can be selected.

Note) Determine the effective torque based on the following data.
When the inertia force is low: 60-80%
When the inertia force is high: 25-35%

Dimensions-Rotating Angle 90°

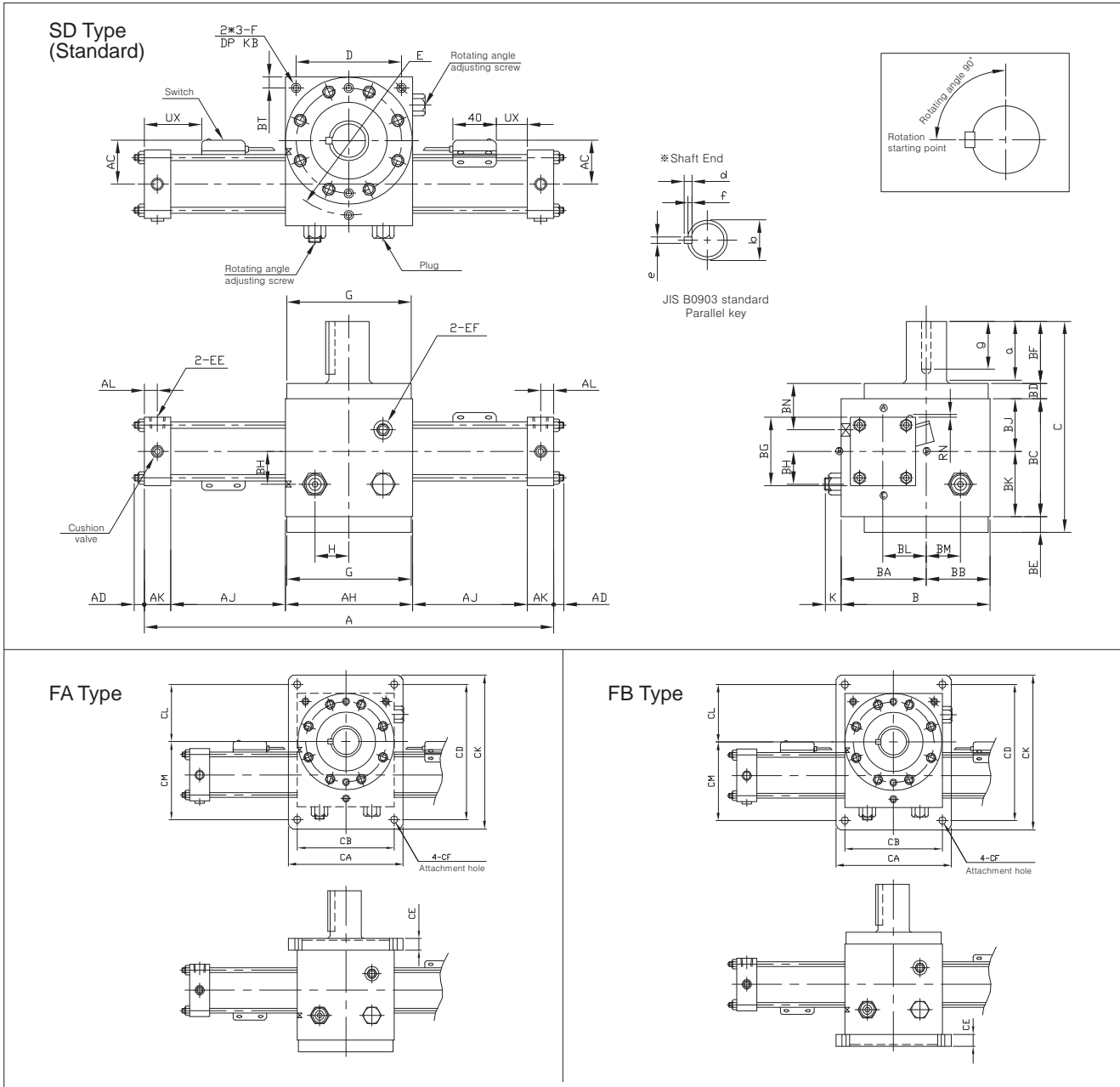

Unit : mm

Bore size	A	AC	AD	AH	AJ	AK	AL	B	BA	BB	BC	BD	BE	BF	BG	BH	BJ	BK	BL	BM	BN	BT	C	CA	CB	CD
302	43	10	88	85	22	10	102	58	44	82	12	12	38	□55	22	36	46	24	20	24.5	20	144	105	85	125	
Ø40	333	47	15	106	87.5	26	13	125	72	53	97	13	14	60	□65	30	43	54	30	27	27	27	184	125	100	150
Ø50	383	53	15	120	101.5	30	15	140	80	60	112	15	15	60	□75	34	50	62	40	33	30	33	202	145	120	170
Ø63	455	59	17	144	125.5	30	15	168	96	72	133	14	16	84	□90	40	60	73	50	40	34	40	247	175	140	210
Ø80	518	67	20	168	139	36	18	200	116	84	156	18	20	84	□110	53	68	88	59	48	35	48	278	210	170	250

Bore size	CE	CF	CK	CL	CM	D	E	EE	EF	F	G	H	K	KB	RN	UX	Shaft end					
																	a	b	d	e	f	g
Ø30	13	Ø9	145	55	70	71.4	101	Rc(PT)1/4	Rc(PT)1/4	M8xP1.25	Ø83h7	20	10	16	7	23	36	Ø22h7	6	6	3	32
Ø40	15	Ø9	180	65	85	86.3	122	Rc(PT)3/8	Rc(PT)3/8	M10xP1.25	Ø104h7	27	12	16	6	27	58	Ø30h7	7	8	4	50
Ø50	16	Ø11	195	75	95	98.3	139	Rc(PT)1/2	Rc(PT)3/8	M10xP1.25	Ø117h7	33	14	20	6	30	58	Ø38h7	8	10	5	50
Ø63	18	Ø14	240	90	120	116.7	165	Rc(PT)1/2	Rc(PT)3/8	M12xP1.5	Ø140h7	40	16	18	4	39	82	Ø50h7	9	14	5.5	70
Ø80	22	Ø16	290	110	140	137.9	195	Rc(PT)3/4	Rc(PT)1/2	M16xP1.5	Ø164h7	48	19	21	3	40	82	Ø55h7	10	16	6	70

Dimensions-Rotating Angle 180°

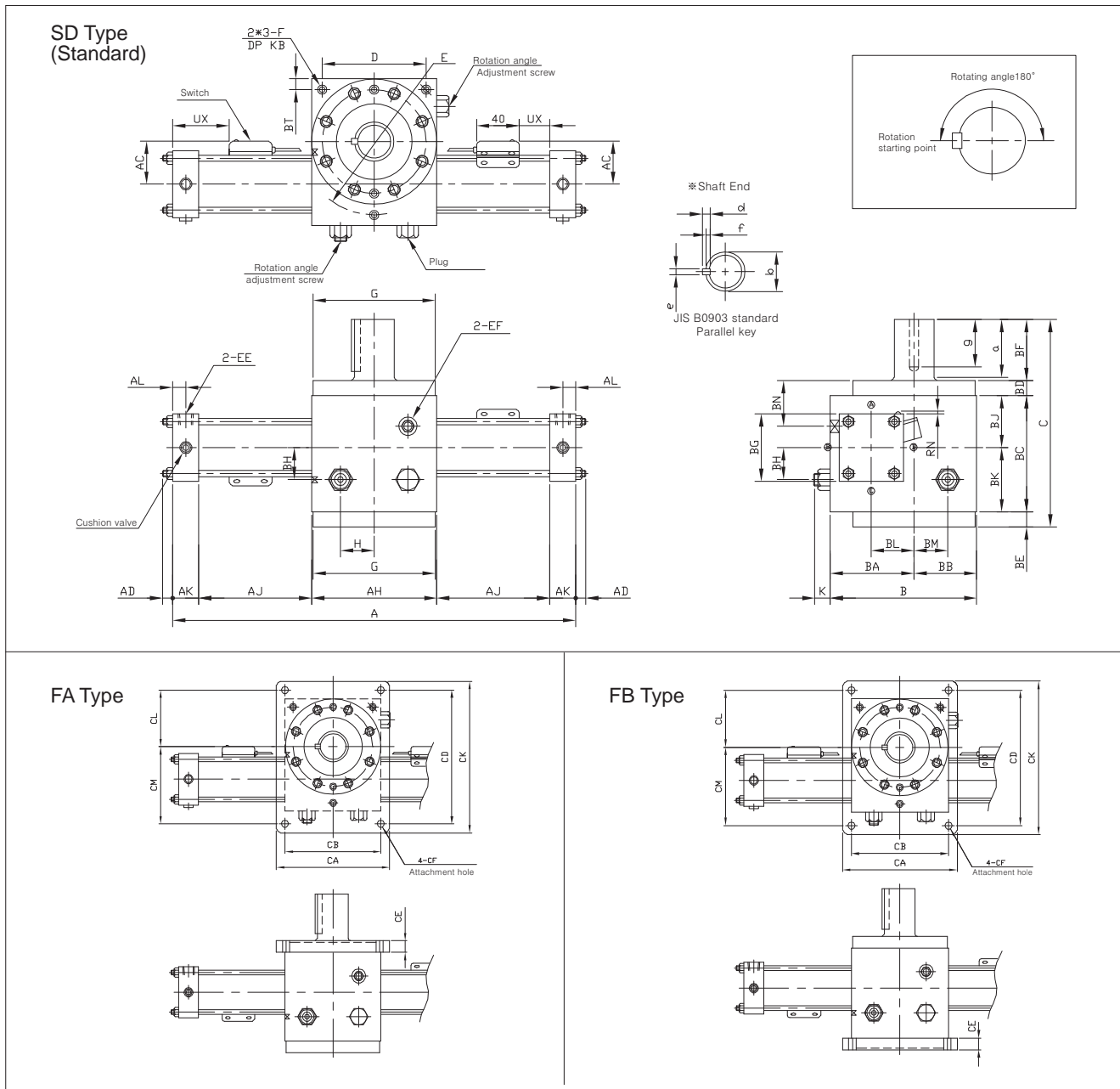

Hydraulic Cylinder
Reference Data
KP140H
KP210H
KPC70/140H
KPC210H
KTC70HP
KP140HS
KP125/160A
KP35R

KH

Unit : mm

Bore size	A	AC	AD	AH	AJ	AK	AL	B	BA	BB	BC	BD	BE	BF	BG	BH	BJ	BK	BL	BM	BN	BT	C	CA	CB	CD
Ø30	369	43	10	88	118.5	22	10	102	58	44	82	12	12	38	□55	22	36	46	24	20	24.5	20	144	105	85	125
Ø40	409	47	15	106	125.5	26	13	125	72	53	97	13	14	60	□65	30	43	54	30	27	27	27	184	125	100	150
Ø50	483	53	15	120	151.5	30	15	140	80	60	112	15	15	60	□75	34	50	62	40	33	30	33	202	145	120	170
Ø63	581	59	17	144	188.5	30	15	168	96	72	133	14	16	84	□90	40	60	73	50	40	34	40	247	175	140	210
Ø80	668	67	22	168	214	36	18	200	116	84	156	18	20	84	□110	53	68	88	59	48	35	48	278	210	170	250

Bore size	CE	CF	CK	CL	CM	D	E	EE	EF	F	G	H	K	KB	RN	UX	Shaft end					
																	a	b	d	e	f	g
Ø30	13	Ø9	145	55	70	71.4	101	Rc(PT)1/4	Rc(PT)1/4	M8xP1.25	Ø83h7	20	10	16	7	23	36	Ø22h7	6	6	3	32
Ø40	15	Ø9	180	65	85	86.3	122	Rc(PT)3/8	Rc(PT)3/8	M10xP1.25	Ø104h7	27	12	16	6	27	58	Ø30h7	7	8	4	50
Ø50	16	Ø11	195	75	95	98.3	139	Rc(PT)1/2	Rc(PT)3/8	M10xP1.25	Ø117h7	33	14	20	6	30	58	Ø38h7	8	10	5	50
Ø63	18	Ø14	240	90	120	116.7	165	Rc(PT)1/2	Rc(PT)3/8	M12xP1.5	Ø140h7	40	16	18	4	39	82	Ø50h7	9	14	5.5	70
Ø80	22	Ø16	290	110	140	137.9	195	Rc(PT)3/4	Rc(PT)1/2	M16xP1.5	Ø164h7	48	19	21	3	40	82	Ø55h7	10	16	6	70

KH series



Features

- Standard agricultural and industrial hydraulic cylinder
- Hydraulic cylinder with bore sizes from Ø40 to Ø400.
- One side installation is possible depending on piping.
- Various mounting styles.
(Both end ring mounting, CA ring mouting, FA, FB)

Symbol

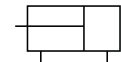

Double Acting / Single Rod

How to Order

KH02 - **FB1** **40** - **S** **1000** **A**

① ② ③ ④ ⑤ ⑥ ⑦ ⑧

① Series

KH01	Both end ring mounting cylinder (For agricultural machine)
KH001	CA ring mounting cylinder (For industry)
KH02	General industry cylinder
KH03	General industry large cylinder

② Seal material

※ For KH01, KH001 series

Nil	Urethane rubber (Standard)
1	Nitrile rubber

※ For KH02, KH03 series

Nil	U Packing (Standard)
1	V Packing

③ Mounting style

SD	Both end ring mounting	For KH01
	CA ring mounting	For KH001
FAR	Rod side flange (Rectangular)	For KH02
	Rod side flange (Circular plate)	
FB1	Head side flange (Rectangular)	
FB2	Head side flange (Circular plate)	
FA	Rod side flange	For KH03
FB	Head side flange	

④ Bore Size

Bore Size	KH01 KH001	KH02	KH03
40	•	•	
50	•	•	
60	•	•	
70	•	•	
80	•	•	
90	•	•	
100	•	•	
110	•	•	
125	•	•	
140	•	•	
150	•	•	
160	•	•	
180		•	
200		•	•
220			•
250			•
280			•
300			•
350			•
400			•

⑤ Tube type

Nil	Drawing tube (Standard Ø40~Ø100)
H	Honing pipe

※ Only available for Ø40~Ø100.

※ Honing pipe is used as standard type for cylinder over Ø125.

⑥ Cylinder Stroke (mm)

Bore size	Max. stroke
Ø40~Ø400	3000

※ Check buckling, as it varies depending on mounting style.

※ Contact us for longer stroke.

⑦ Piping type

Nil	A: Both side piping (Standard)
BH	Head side piping

※ Only available for KH01, KH001, KH03 series.

⑧ Piping position

A	Standard
B, C, D	Refer to figure below

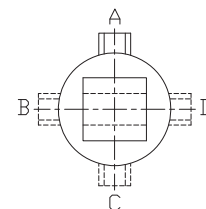

Specifications

Type	KH01, KH001, KH02, KH03
Max. operating pressure	100kgf/cm ² (10.0MPa)
Proof pressure	200kgf/cm ² (20.0MPa)
Min. operating pressure	5kgf/cm ² (0.5MPa)
Temperature range	-10 ~ 60°C
Working oil	Petroleum-based fluid
Tolerance of thread	KS class 2
Tolerance of stroke	0 ~ 0.8mm (KH02, KH03)

Stroke Tolerance

Unit : mm

Bore Size	40	50	60	70	80	90	100
Tolerance	-	+6	-1	-5	-5	-10	-10

※ Available for KH01, KH001 series.

Dimensions-Both End Ring Mounting Cylinder (KH01: Agricultural Machine)

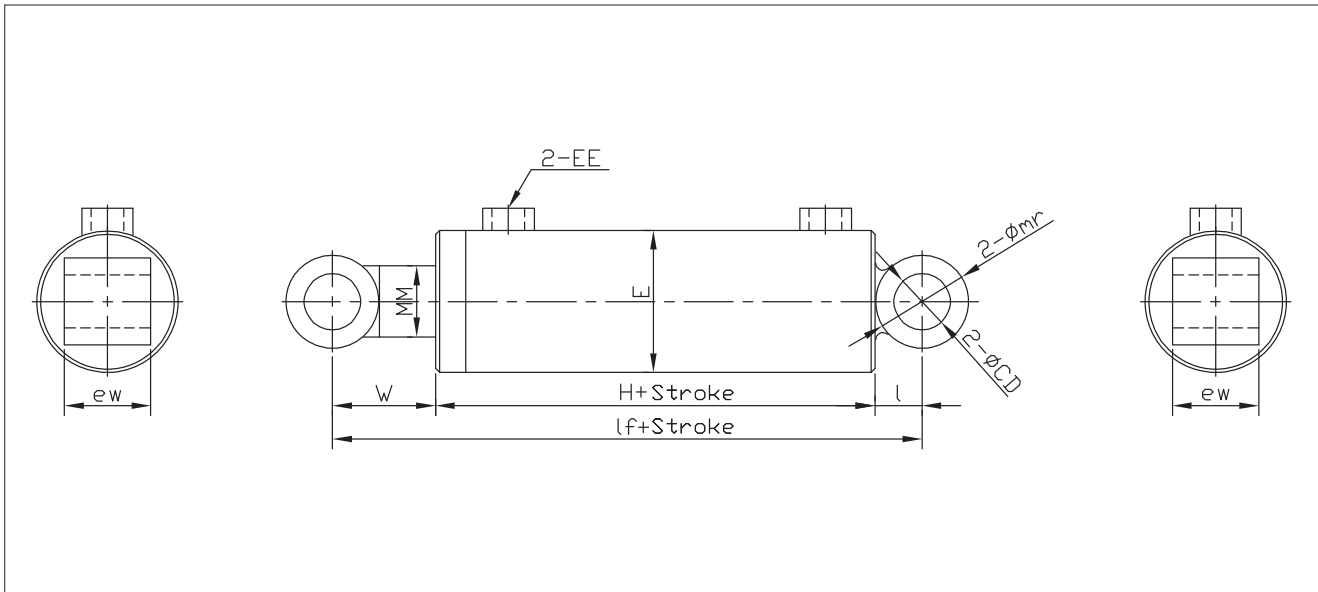

Dimensions-CA Ring Mounting Cylinder (KH001: Industry)

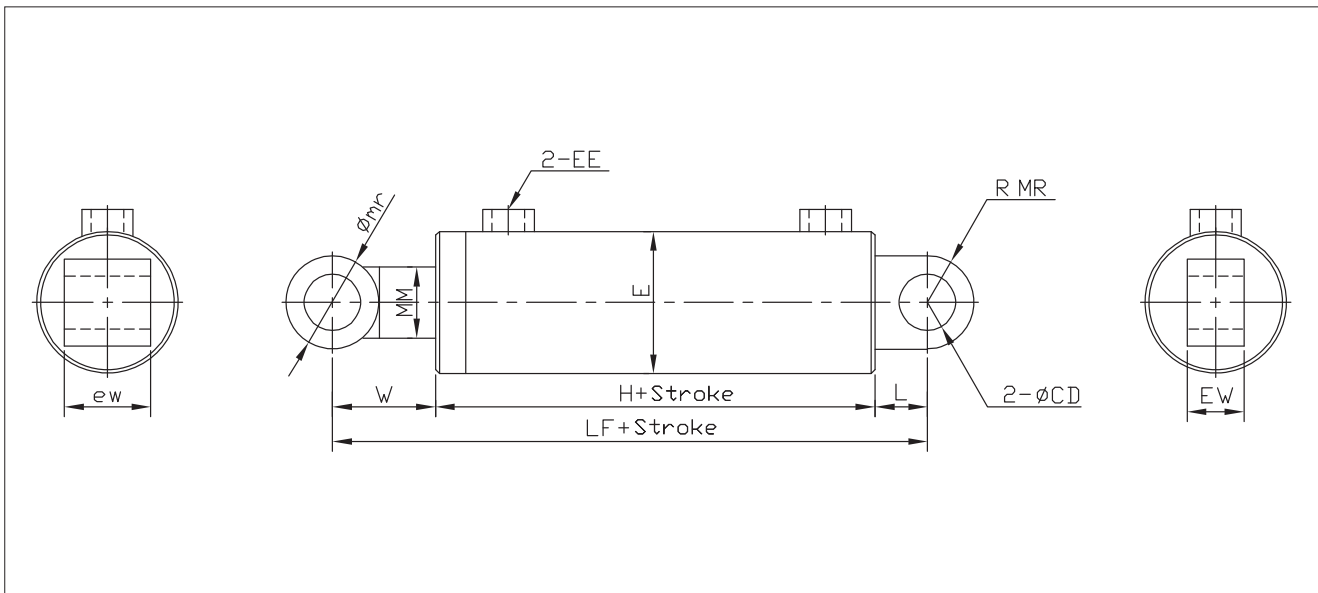

Unit : mm

Bore size	ØCD	ØE	EE	EW	H	L	LF	ØMM	R MR	W	Ømr	ℓ	ff	ew
Ø40	Ø25.5	Ø50	3/8	30	125	49	226	Ø25	25	52	44	22	199	40
Ø50	Ø25.5	Ø60	3/8	30	163	49	266	Ø30	25	54	44	22	239	40
Ø60	Ø25.5	Ø70	3/8	30	163	49	266	Ø40	25	54	44	22	239	*45/40
Ø70	Ø25.5	Ø80	1/2	35	163	39	256	Ø40	27	54	44	22	239	45
Ø80	Ø25.5	Ø90	1/2	35	163	39	256	Ø40	27	54	44	22	239	45
Ø90	Ø35.5	Ø100	1/2	40	163	49	271.5	Ø50	37	59.5	55	27.5	250	55
Ø100	Ø35.5	Ø110	1/2	40	163	49	271.5	Ø50	37	59.5	55	27.5	250	55
Ø110	Ø35.5	Ø130	1/2	40	183	49	297	Ø55	37	65	60	30	278	60
Ø125	Ø35.5	Ø145	1/2	45	184	60	314	Ø60	40	70	70	35	289	65
Ø140	Ø38.5	Ø160	1/2	50	189	60	324	Ø65	40	75	80	40	304	70
Ø150	Ø38.5	Ø168	1/2	50	194	60	329	Ø65	40	75	80	40	309	70
Ø160	Ø40.5	Ø180	1/2	60	195	70	345	Ø70	40	80	90	45	320	80

* For Ø60, front ring ew=45 and back ring ew=40 are the basic dimensions.

Dimensions-General Industry Cylinder (KH02)

FA Type

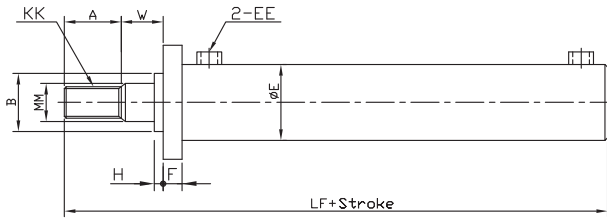

FB Type

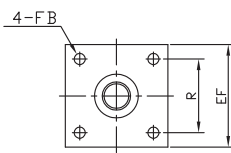
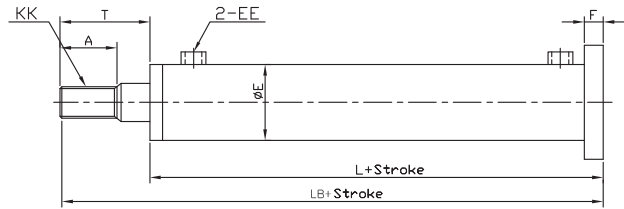

FAR, FBR

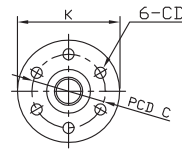

FAC, FBC

Unit : mm

Bore size	A	ØB	C	ØCD	ØE	EE	EF	F	ØFB	H	ØK	L	LB	LF	ØMM	ØR	T	KK	W
Ø40	40	50	95	14.5	50	3/8	90	15	14.5	10	120	130	190	185	Ø25	65	60	M22xP1.5	30
Ø50	45	60	95	14.5	60	3/8	90	15	14.5	13	120	162	227	222	Ø30	65	65	M25xP1.5	33
Ø60	50	70	105	14.5	70	3/8	110	15	14.5	13	130	169	239	234	Ø40	80	70	M36xP1.5	33
Ø70	50	80	115	14.5	80	1/2	110	18	14.5	13	140	176	246	238	Ø40	80	70	M36xP1.5	33
Ø80	50	90	130	14.5	90	1/2	135	20	14.5	13	160	176	246	238	Ø40	102	70	M36xP1.5	43
Ø90	50	100	150	17.5	100	1/2	135	20	17.5	13	180	183	263	253	Ø45	102	80	M40xP1.5	43
Ø100	50	110	160	17.5	110	1/2	150	20	17.5	13	190	183	263	253	Ø50	115	80	M45xP1.5	43
Ø125	50	140	195	17.5	145	1/2	165	25	17.5	13	220	194	274	264	Ø60	134	80	M56xP2.0	43
Ø140	50	160	210	17.5	160	1/2	196	25	17.5	13	240	194	274	265	Ø65	148	80	M56xP2.0	43
Ø150	50	170	220	17.5	168	1/2	196	25	17.5	13	250	199	279	275	Ø65	148	80	M56xP2.0	43
Ø160	60	180	230	17.5	180	1/2	210	30	20.0	13	260	200	300	285	Ø70	170	90	M64xP2.0	43
Ø180	60	200	254	17.5	202	3/4	220	30	20.0	15	285	236	336	331	Ø80	180	100	M72xP2.0	53
Ø200	80	220	290	20.0	230	3/4	260	35	20.0	15	330	245	365	363	Ø90	220	120	M80xP2.0	53

Dimensions-General Industry Large Size Cylinder (KH03)

Rod Side Flange(FA)

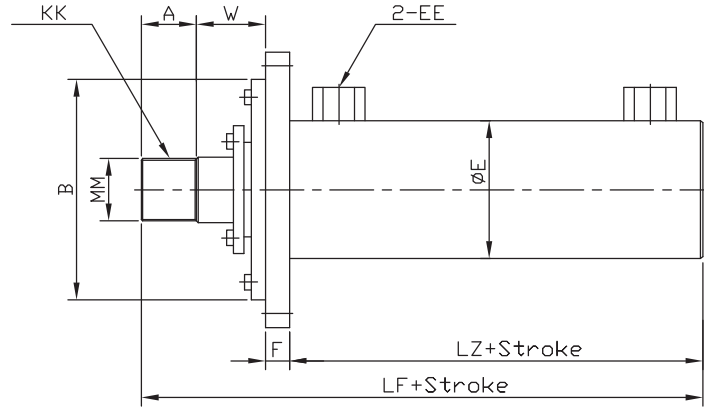
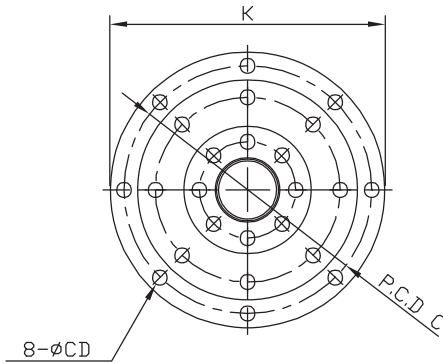

Head Side Flange(FB)

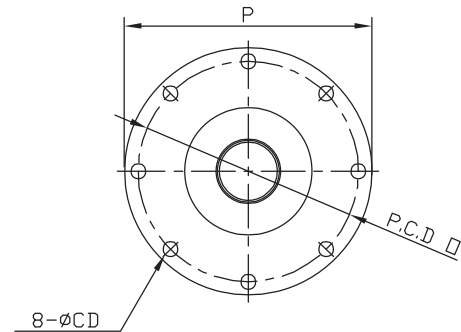
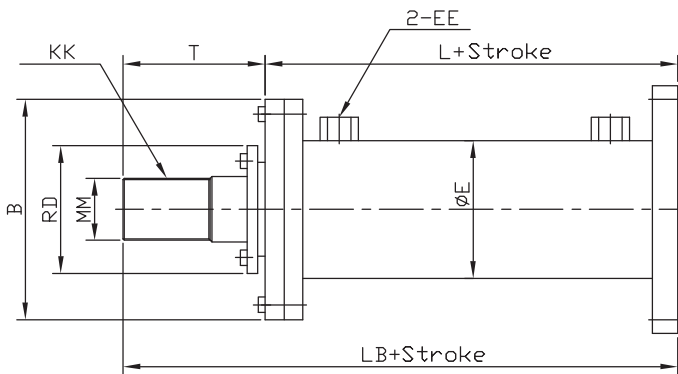

Unit : mm

Bore size	A	∅B	C	∅CD	∅E	EE	F	∅K	KK	L	LB	LF	LZ	MM	O	∅P	∅RD	T	W
∅200	80	320	360	∅22	245	1	35	400	M90xP2.0	265	445	415	200	∅95	300	340	160	180	100
∅220	80	350	390	∅22	260	1	35	440	M100xP2.0	265	445	415	200	∅105	310	360	170	180	100
∅250	90	390	440	∅22	300	1	40	490	M110xP2.0	309	499	452	222	∅115	360	410	180	190	100
∅280	90	430	470	∅25	330	1 1/4	45	520	M120xP2.0	354	544	492	257	∅125	400	450	200	190	100
∅300	100	450	520	∅25	350	1 1/4	45	580	M125xP3.0	359	579	522	257	∅130	420	470	210	220	120
∅350	120	550	620	∅25	410	1 1/4	50	680	M150xP3.0	374	614	552	262	∅160	500	560	240	240	120
∅400	120	620	700	∅25	480	1 1/2	55	760	M150xP3.0	389	659	592	267	∅160	580	640	240	270	150

Hydraulic Cylinder

Reference Data

KP140H

KP210H

KPC70/140H

KPC210H

KTC70HP

KP140HS

KP125/160A

KP35R

KH