

General

As an alternative to the cylinders of series 1300 (1301-1302) which have been previously illustrated, let's consider and analyze the cylinders of the 1303 CNOMO (1304 CETOP - 1305 ISO) series.

As we have already mentioned in the general description, these cylinders are particularly strong and reliable, they can be used in many ways and fitted with various elements so that they can solve all sorts of problems. Their construction is similar to that of low pressure hydraulic cylinders: strong aluminium piston, lip seal, teflon guide shoe on piston; cylinder heads are obtained from bar up to 100 in diameter and from chill casting followed by a radiographic control from the diameter 125 to 200. Also they are designed to withstand such stresses as to make cylinders suitable for operating with oil up to 20 Bar. In this case, the rod-guide bushing is slightly modified, suitable seals are used and tie-rods are strengthened to provide further safety. Obviously, all versions of our cylinders come with shock absorbing systems and quick start with a particularly fine deceleration control. Even in this type of cylinder, the rod-guide bushing is dismountable from the end-cape and it is always made with anti-friction material.

The anchorage devices (clamps) are the same as those of the series 1300, with small variation only on the flange threads to attach tie-rods, which are substituted by spot-facing for socket head screw. In fact, for such a series of cylinders, tie-rods do not protrude from the cylinder heads but they are partially kept by female thread screws. In fact, the remaining part of the screws thread is used for locking the clamps by socket head or hexagonal-head screws.

Among the various specifications there are also standard stroke cylinders, with strokes not superior to 50 mm. The ordering code is obtained by adding the letters MA for the front spring and MP for the rear spring.

For example: **1303.32.50.01MA**
 1303.40.25.01MP

Construction characteristics

End plates	solid aluminium bar up to Ø 100, alloy aluminium from Ø 125 to Ø200
Rod	C43 chromed steel, by thickness or stainless steel AISI 303
Barrel	polished extruded cold steel of high quality with roughness max RA 0,15 or barrels in oxidized aluminium.
Tie rods	steel with rolled threads
Cushion bearings	aluminium
Rod-guide bushing	brass (Ø 32, 40, 50) in aluminium with self-lubricating bearings in sinterized bronze for the remaining diameters
Piston	aluminium lathed from bar
Piston seals	NBR 80 Shore rubber (or VITON)
Rod seals	mixing polyurethane self-lubricating 90 Shore or VITON

Technical characteristics

Fluid	filtered and lubricated air - hydraulic oil									
Pressure	max 12 bar (air) - 20 bar (oil)									
Operating temperature	-5 °C to + 70°C (150 °C with VITON)									
Cushioning length	Ø	32	40	50	63	80	100	125	160	200
	mm.	20	20	22	24	24	25	27	35	35

Standard strokes

From 0 to 150 every 25 mm; from 150 to 500 every 50 mm; from 500 to 1000 every 100 mm. (For all diameters)

Maintenance and use

The cylinder is a very simple and sturdy component. A correct use will provide it with a reliable and long life for many millions of cycles.

Clean and lubricated air is rule number one. When assembling the cylinder, align correctly in relation to the loaded capacity which does not generate radial components and/or bending the rod. Avoid the combination of a heavy load, long stroke, and high velocity (in this case please contact our engineering dept for eventual application of extra cushionings). Evaluating with care processing conditions sometimes allows avoiding frequent maintenance interventions.

When the cylinder needs to be repaired, use the standard practices. Disassemble the cylinder, wash all parts in a mild degreasing media (petrol, oil, etc.) and, after having checked and replaced the worn parts, lubricate with special grease and reassemble. Particular attention must be paid to all sliding surfaces, barrel and rod. If damaged, they will shortly wear out the newly replaced seals. Check that play between bushing and rod isn't over 0.2 mm (again the tolerance is +0.05 +0.07 mm). Whenever the tolerance exceeds 0.2 mm, the seals become ineffective. Finally, please bear in mind that under bad conditions and with air condensation, one of the most delicate points of the cylinder is the non-treated steel barrel, which is very sensitive to rust. This provokes irreversible damage to the internal surface of the barrel and the accelerated wear of the seals. When in doubt, the burnished barrels should be used. For lubrication use class H hydraulic oils, for example Castrol MAGNAGC 32.

Important

We recommend an adequate programmed lubrication and inspection of the fixing devices such as intermediate trunnion, rear trunnion, clevis, and so on for verifying their efficiency.

Basic version

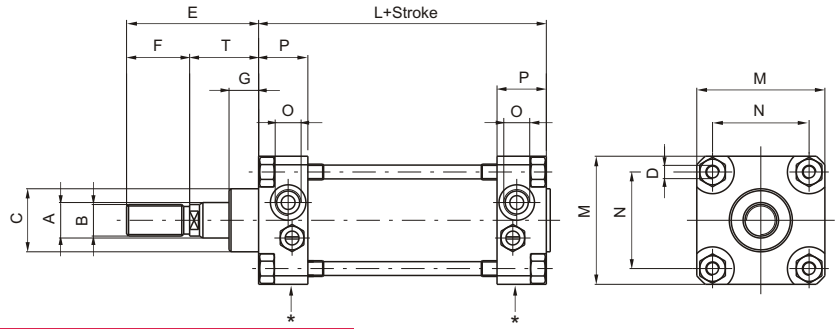

Ordering code	Available barrels
1303.Ø.stroke.01 (CNOMO) steel barrel 1304.Ø.stroke.01 (CETOP) steel barrel 1305.Ø.stroke.01 (ISO) steel barrel (From Ø 32 to Ø 100)	1303 (1304 - 1305).Ø.stroke.01A aluminium barrel

Push/Pull version

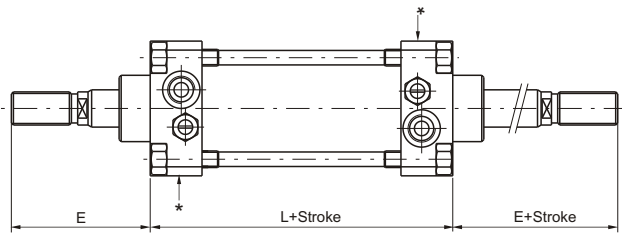

Ordering code	Available barrels
1303.Ø.stroke.02 (CNOMO) steel barrel 1304.Ø.stroke.02 (CETOP) steel barrel 1305.Ø.stroke.02 (ISO) steel barrel (From Ø 32 to Ø 100)	1303 (1304 - 1305).Ø.stroke.02A aluminium barrel

Tandem push with a common rod

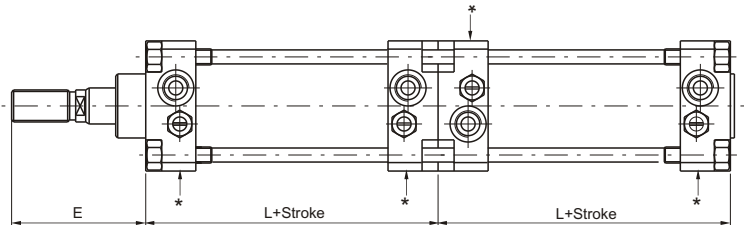

Ordering code	Available barrels
1303.Ø.stroke.G (CNOMO) steel barrel 1304.Ø.stroke.G (CETOP) steel barrel 1305.Ø.stroke.G (ISO) steel barrel (From Ø 32 to Ø 100)	1303 (1304 - 1305).Ø.stroke.H aluminium barrel

Tandem push with independent rods

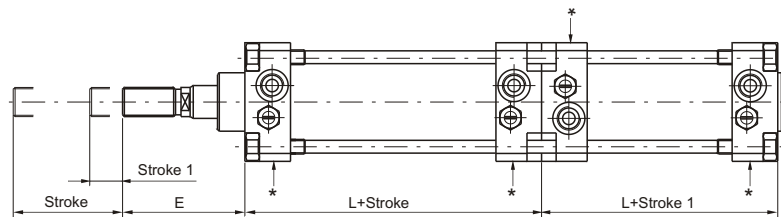

Ordering code	Available barrels
1303.Ø.stroke.stroke1.F (CNOMO) steel barrel 1304.Ø.stroke.stroke1.F (CETOP) steel barrel 1305.Ø.stroke.stroke1.F (ISO) steel barrel (From Ø 32 to Ø 100)	1303 (1304 - 1305).Ø.stroke.stroke1.N aluminium barrel

Opposed tandem with common rods

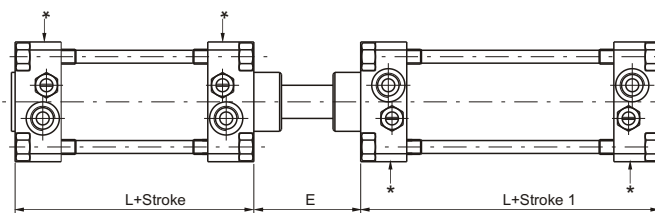

Ordering code	Available barrels
1303.Ø.stroke.stroke1.D (CNOMO) steel barrel 1304.Ø.stroke.stroke1.D (CETOP) steel barrel 1305.Ø.stroke.stroke1.D (ISO) steel barrel (From Ø 32 to Ø 100)	1303 (1304 - 1305).Ø.stroke.stroke1. aluminium barrel

Tandem with opposed rods

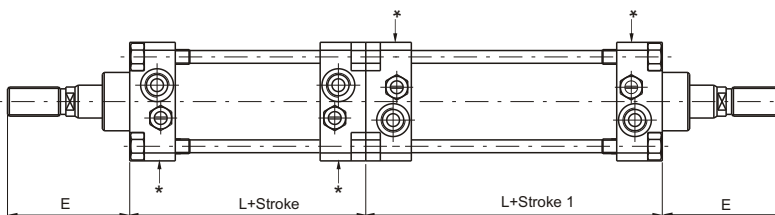

Ordering code	Available barrels
1303.Ø.stroke.stroke1.E (CNOMO) steel barrel 1304.Ø.stroke.stroke1.E (CETOP) steel barrel 1305.Ø.stroke.stroke1.E (ISO) steel barrel (From Ø 32 to Ø 100)	1303 (1304 - 1305).Ø.stroke.stroke1.U steel barrel

NOTE: to order cylinders with STAINLESS STEEL chromed rods add "X" to the cylinder code. Example: **1303.32.250.01X**.
 to order cylinders with VITON® seals add "V" to the cylinder code. Example: **1303.32.250.01V**.

Cushion adjustment (for Ø 32, Ø 40, Ø 125, Ø 160 and Ø 200) is on the side indicated by* (see drawings).

Table of dimensions

Bore	32	40	50	63	80	100	125	160	200
A (f7)	12	18	18	22	22	30	30	40	40
B - CNOMO (6g)	M10x1,5	M16x1,5	M16x1,5	M20x1,5	M20x1,5	M27x2	M27x2	M36x2	M36x2
B - CETOP (6g)	M10x1,25	M12x1,25	M16x1,5	M16x1,5	M20x1,5	M20x1,5	M24x2	M36x2	M36x2
B - ISO (6g)	M10x1,25	M12x1,25	M16x1,5	M16x1,5	M20x1,5	M20x1,5	M27x2	M36x2	M36x2
C (d11)	25	32	32	45	45	55	55	65	65
D	M6	M6	M8	M8	M10	M10	M12	M16	M16
E - CNOMO	45	70	70	85	85	110	110	135	135
E - CETOP	44	52	67	67	82	87	109	152	162
E - ISO	46	52	67	67	82	87	115	152	162
F - CNOMO	20	36	36	46	46	63	63	85	85
F - CETOP	20	24	32	32	40	40	48	72	72
F - ISO	22	24	32	32	40	40	54	72	72
G	15	15	15	20	20	20	20	25	25
M	45	52	65	75	95	115	140	180	220
N	33	40	49	59	75	90	110	140	175
O	G 1/8"	G 1/4"	G 1/4"	G 3/8"	G 3/8"	G 1/2"	G 1/2"	G 3/4"	G 3/4"
P	16	23	25	31	31	35	36	45	45
T - CNOMO	25	34	34	39	39	47	47	50	50
T - CETOP-ISO	24	28	35	35	42	47	61	80	90
L - CNOMO (±1)	80	110	110	125	125	145	145	180	180
L - CETOP-ISO (±1)	98	110	110	125	136	145	168	180	190

STROKE TOLLERANCE: + 2 mm.

WEIGHT IN gr. OF THE CYLINDERS WITH VARIOUS BARRELS (BASIC VERSION)

Bore		32	40	50	63	80	100	125	160	200
Steel	Stroke 0	650	1090	1500	2300	3600	5750	8150	14500	20000
	every 10 mm.	35	51	69	96	104	155	200	365	415
Aluminium	Stroke 0	580	1010	1350	2110	3350	5400	7450	13300	18300
	every 10 mm.	24	38	47	63	75	117	130	235	250

FOR CYLINDERS IN TANDEM THE WEIGHT IS APPROXIMATELY DOUBLE

Drawing

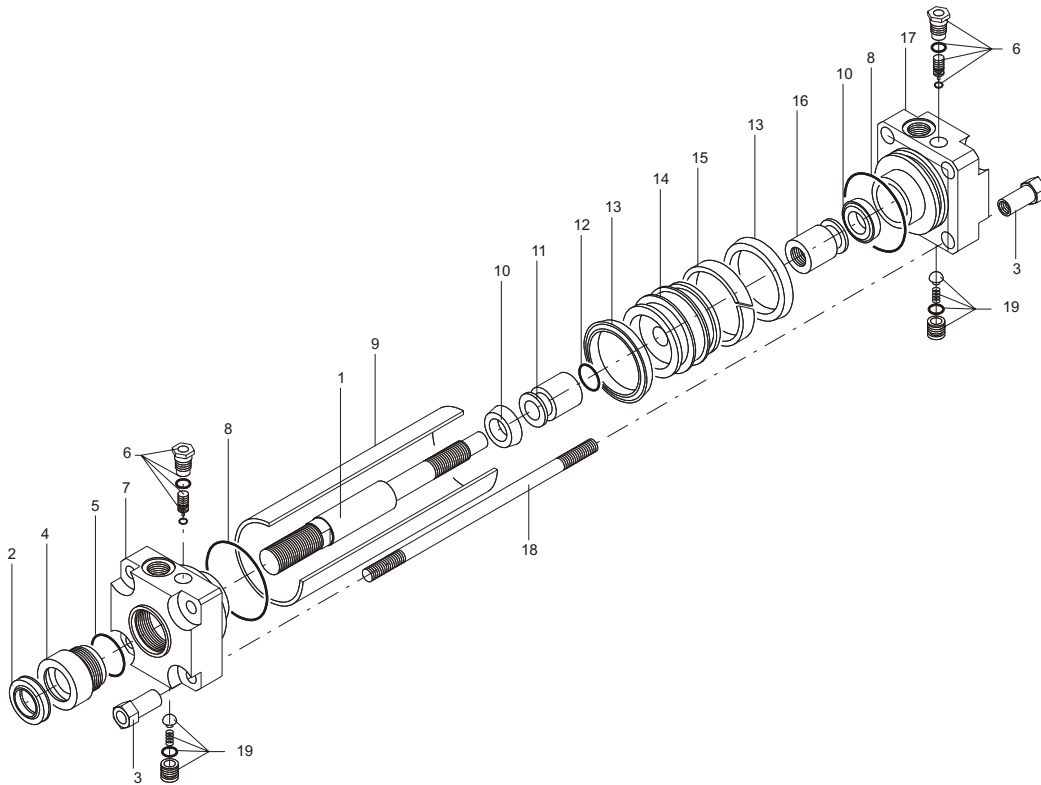

4

Pos.	Description	N. Pieces
1	Cylinder rod	1
2	Piston rod bearing seal	1
3	Tie rod nut	8
4	Piston rod bearing	1
5	Seals bearing-cover	1
6	Cushion adjustment	2
7	Front cover	1
8	Cover seal	2
9	Barrel	1
10	Cushion seal	2
11	Front cushion bearing	1
12	Cushion bearing seal	1
13	Piston seal	2
14	Piston	1
15	Teflon wear ring	1
16	Rear cushion bearing	1
17	Rear cover	1
18	Tie rod	4
19	Quick start valve	2

General

These cylinders, manufactured in sizes 1-1/4" through 8" diameter, are derived from the 1303 CNOMO (1304 - 1305 CETOP - ISO) series. They come with a piston with plastoferrite magnetic inserts. The adoption of a diamagnetic barrel in oxidized aluminium, permits the magnetic field generated by the piston to activate reed contacts mounted externally on the barrel. It is a high quality cylinder, adapt at any use, even the heaviest ones; long strokes and slightly off-balanced loads are conditions that this type of cylinder supports easily since it is equipped with a teflon guide shoe. In the use of magnetic cylinders, special attention must be paid to the technical notes shown on the pages about the 1200 series sensors, which are the same as this series of cylinders. The accessories for mounting are the same used for the 1303 - 1304 - 1305 series, given that the overall dimensions are the same..

Basic version

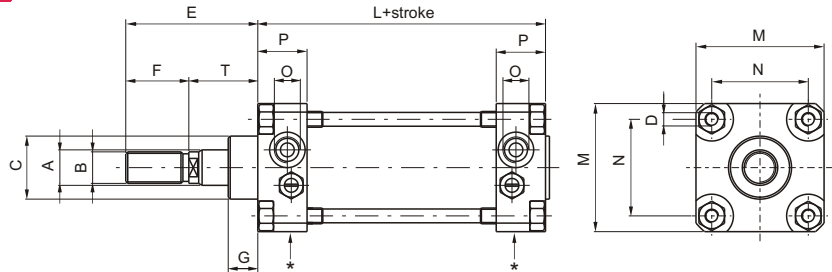

Ordering code

- 1306.Ø.stroke.01A aluminium barrel
- 1307.Ø.stroke.01A aluminium barrel
- 1308.Ø.stroke.01A aluminium barrel

Push/Pull Version

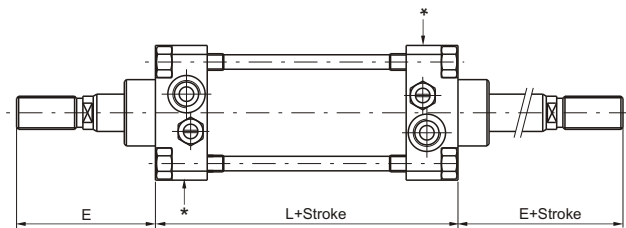

Ordering code

- 1306.Ø.stroke.02A aluminium barrel
- 1307.Ø.stroke.02A aluminium barrel
- 1308.Ø.stroke.02A aluminium barrel

Tandem in spinta stelo comune

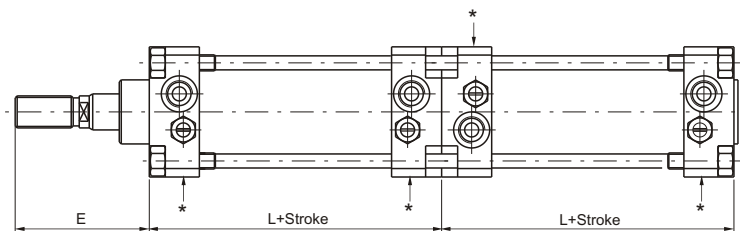

Ordering code

- 1306.Ø.stroke.H aluminium barrel
- 1307.Ø.stroke.H aluminium barrel
- 1308.Ø.stroke.H aluminium barrel

Tandem push with independent rods

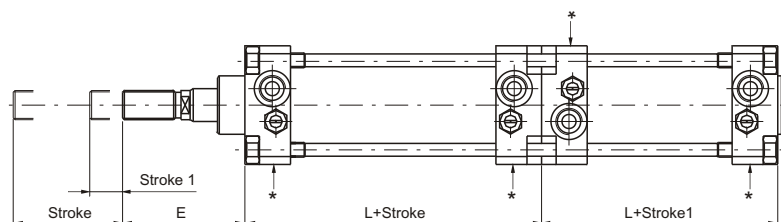

Ordering code

- 1306.Ø.stroke.stroke1.N aluminium barrel
- 1307.Ø.stroke.stroke1.N aluminium barrel
- 1308.Ø.stroke.stroke1.N aluminium barrel

Opposed tandem with common rods

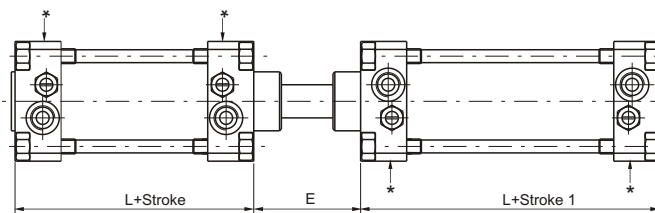

Ordering code

1306.Ø.stroke.stroke1.R aluminium barrel
1307.Ø.stroke.stroke1.R aluminium barrel
1308.Ø.stroke.stroke1.R aluminium barrel

Tandem with opposed rods

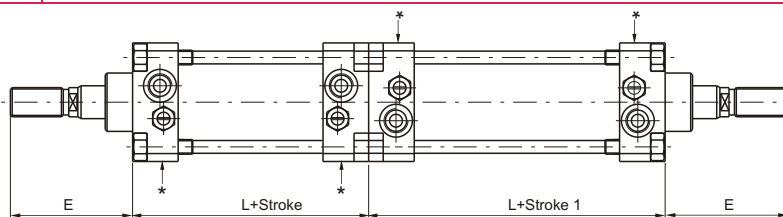

Ordering code

1306.Ø.stroke.stroke1.U aluminium barrel
1307.Ø.stroke.stroke1.U aluminium barrel
1308.Ø.stroke.stroke1.U aluminium barrel

to order cylinders with STAINLESS STEEL chromed rods add "X" to the cylinder code. Example:**1306.32.250.01AX**.
to order cylinders with VITON® seals add "V" to the cylinder code. Example:**1306.32.250.01AV**.

Cushion adjustment (for Ø 32, Ø 40, Ø 125, Ø 160 and Ø 200) is on the side indicated by★ (see drawings).

Table of dimensions

Bore	32	40	50	63	80	100	125	160	200
A (f7)	12	18	18	22	22	30	30	40	40
B - CNOMO (6g)	M10x1,5	M16x1,5	M16x1,5	M20x1,5	M20x1,5	M27x2	M27x2	M36x2	M36x2
B - CETOP (6g)	M10x1,25	M12x1,25	M16x1,5	M16x1,5	M20x1,5	M20x1,5	M24x2	M36x2	M36x2
B - ISO (6g)	M10x1,25	M12x1,25	M16x1,5	M16x1,5	M20x1,5	M20x1,5	M27x2	M36x2	M36x2
C (d11)	25	32	32	45	45	55	55	65	65
D	M6	M6	M8	M8	M10	M10	M12	M16	M16
E - CNOMO	45	70	70	85	85	110	110	135	135
E - CETOP	44	52	67	67	82	87	109	152	162
E - ISO	46	52	67	67	82	87	115	152	162
F - CNOMO	20	36	36	46	46	63	63	85	85
F - CETOP	20	24	32	32	40	40	48	72	72
F - ISO	22	24	32	32	40	40	54	72	72
G	15	15	15	20	20	20	20	25	25
M	45	52	65	75	95	115	140	180	220
N	33	40	49	59	75	90	110	140	175
O	G 1/8"	G 1/4"	G 1/4"	G 3/8"	G 3/8"	G 1/2"	G 1/2"	G 3/4"	G 3/4"
P	16	23	25	31	31	35	36	45	45
T - CNOMO	25	34	34	39	39	47	47	50	50
T - CETOP-ISO	24	28	35	35	42	47	61	80	90
L - CNOMO (±1)	80	110	110	125	125	145	145	180	180
L - CETOP-ISO (±1)	98	110	110	125	136	145	168	180	190

STROKE TOLLERANCE: + 2 mm.

WEIGHT IN gr. OF THE CYLINDERS WITH VARIOUS BARRELS (BASIC VERSION)

Bore	32	40	50	63	80	100	125	160	200
Aluminium	stroke 0	580	1010	1350	2110	3350	5400	7450	13300
	every 10 mm	24	38	47	63	75	117	130	235

FOR CYLINDERS IN TANDEM THE WEIGHT IS APPROXIMATELY DOUBLE

Drawing

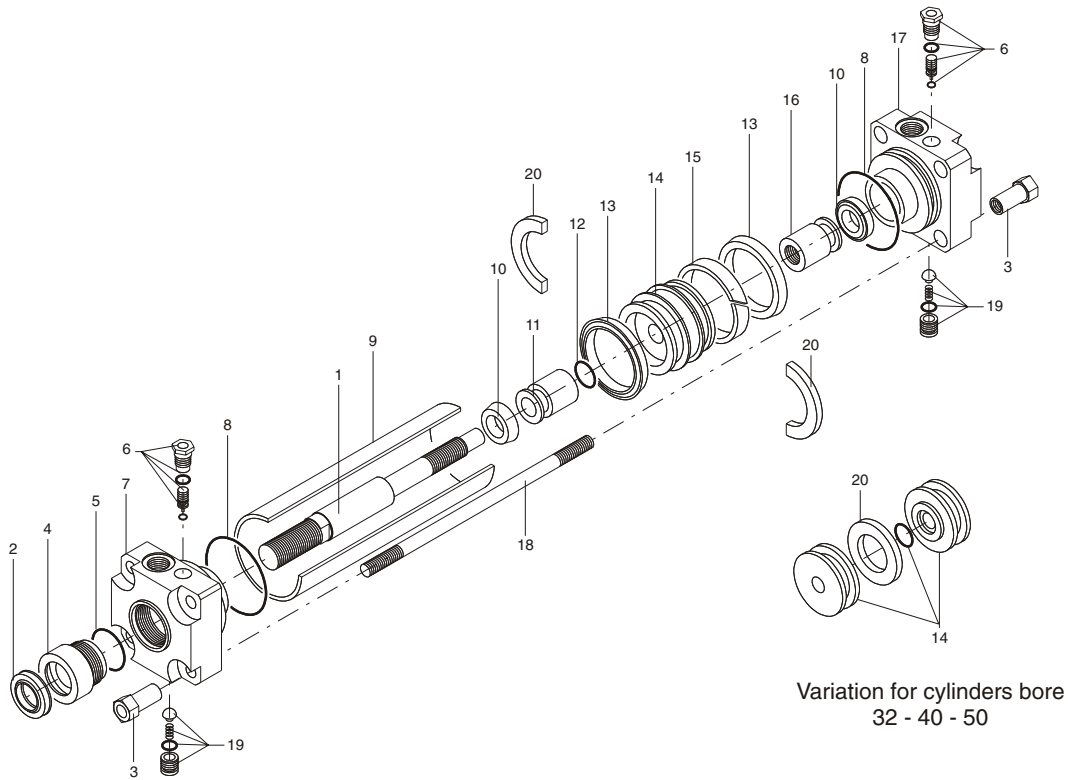

4

Pos.	Description	N. Pieces
1	Rod	1
2	Piston rod bearing seal	1
3	Tie rod nut	8
4	Piston rod bearing	1
5	Seals bearing-cover	1
6	Cushion adjustment	2
7	Front cover	1
8	Cover seal	2
9	Barrel	1
10	Cushion seal	2
11	Front cushion bearing	1
12	Cushion bearing seal	1
13	Piston seal	2
14	Piston	1
15	Teflon wear ring	1
16	Rear cushion bearing	1
17	Rear cover	1
18	Tie rod	4
19	Quick start valve	2
20	Magnet	2

Sensor brackets

Dimensions

Bore	L
Ø 32	59
Ø 40	65
Ø 50	76
Ø 63	87
Ø 80	103
Ø 100	121
Ø 125	144
Ø 160	179
Ø 200	215
Ø 250	275

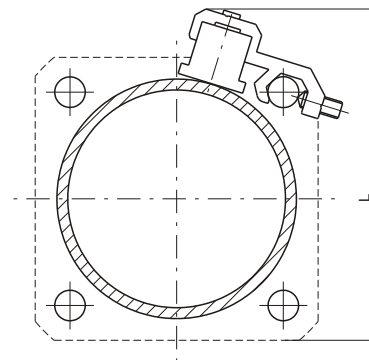

Ordering code	1306.A	Bracket for cylinder sensors Ø 32 ÷ 63
	1306.B	Bracket for cylinder sensors Ø 80 ÷ 125
	1306.C	Bracket for cylinder sensors Ø 160 - 200
	1306.D	Bracket for cylinder sensors Ø 250 (only for ISO version, page.4.51)

Sensors for cylinders

For technical characteristics and ordering code see capitol 6.00 "magnetic sensors"

Front and rear flanges

Ordering code

Front
1303.Ø.03F
(CNOMO)
1304.Ø.03F
(CETOP - ISO)
Rear
1303.Ø.04F
(CNOMO)
1304.Ø.04F
(CETOP - ISO)

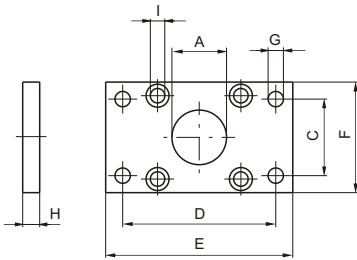
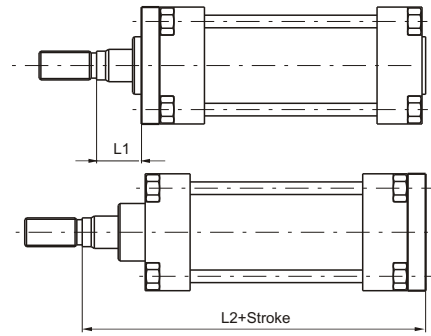

Bore	32	40	50	63	80	100	125	160	200
A (H 11)	25	32	32	45	45	55	55	65	65
C - CNOMO (JS 14)	33	40	49	59	75	90	110	140	175
C - CETOP - ISO (JS 14)	32	36	45	50	63	75	90	115	135
D - CNOMO (JS 14)	68	78	94	104	130	150	180	228	268
D - CETOP - ISO (JS 14)	64	72	90	100	126	150	180	230	270
E	80	90	110	120	150	170	205	260	300
F	45	52	65	75	95	115	140	180	220
G - CNOMO (H 13)	9	9	11	11	14	14	18	22	22
G - CETOP - ISO (H 13)	7	9	9	9	12	14	16	18	22
H (JS 14)	8	8	10	10	12	12	16	20	20
I (TCEI)	6x10	6x10	8x12	8x16	10x20	10x20	12x25	16x30	16x30
L1 - CNOMO	17	26	24	29	27	35	31	30	30
L1 - CETOP - ISO	16	20	25	25	30	35	45	60	70
L2 - CNOMO	113	152	154	174	176	204	208	250	250
L2 - CETOP - ISO	130	145	155	170	190	205	245	280	300
Weight gr.	165	200	540	1060	1460	1510	3100	6400	9500

Plate which allows anchorage of the cylinder at a right angle to the plane. It is made of zinc-plated extruded steel.

Standard feet

Ordering code

1303.Ø.05F
(CNOMO)
(1 piece)
1304.Ø.05F
(CETOP - ISO)
(1 piece)

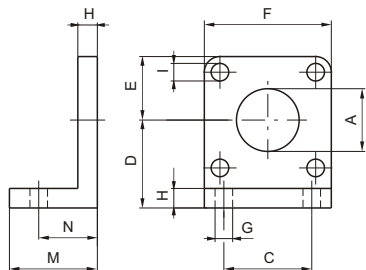
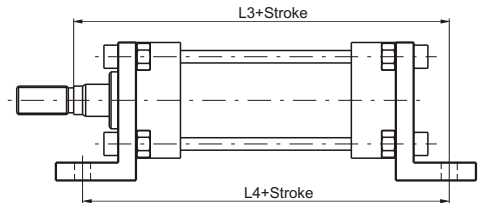

Elements used to anchor the cylinder parallel to the mounting plane. They are made of cast aluminium, painted black.

Bore	32	40	50	63	80	100	125	160	200
A (H 11)	25	32	32	45	45	55	55	65	65
C - CNOMO (JS 14)	28	36	45	55	70	90	100	130	170
C - CETOP - ISO (JS 14)	32	36	45	50	63	75	90	115	135
D - CNOMO (JS 15)	32	36	45	50	63	73	91	115	135
D - CETOP - ISO (JS 15)	32	36	45	50	63	71	90	115	135
E	22	26	32	37	47	57	70	90	110
F	45	52	65	75	95	115	140	180	220
G - CNOMO (H 14)	9	9	11	11	14	14	18	22	22
G - CETOP (H 14)	7	9	9	9	12	14	16	18	22
G - ISO (H 14)	7	9	9	9	12	14	16	18	22
H	8	8	10	10	12	12	16	20	20
I	7	7	9	9	11	11	13	17	17
M	35	35	45	45	55	55	68	82	91
N - CNOMO (± 0,2)	27	27	35	35	43	43	52	62	62
N - CETOP - ISO (± 0,2)	22	25,5	30	30	37	37,5	41	60	65
L3 - CNOMO	132	171	179	199	207	235	244	292	292
L3 - CETOP - ISO	144	163	175	190	215	230	270	320	345
L4 - CNOMO	134	164	180	195	211	231	249	304	304
L4 - CETOP - ISO	142	167	170	185	210	220	250	300	320
Weight gr.	55	70	150	175	260	550	920	2200	3200

Short sheet metal feet

Ordering code

1303.Ø.05/1F
(1 piece)
(CNOMO - CETOP - ISO)

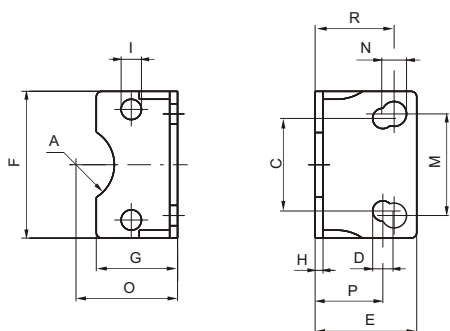
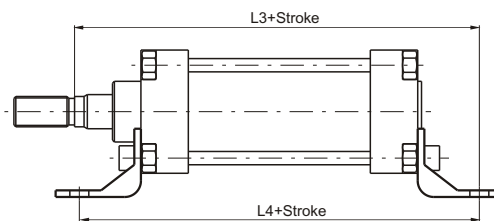

Elements used to anchor the cylinder parallel to the mounting plane. They are made of stamped and pierced sheet metal and painted in black. The mounting holes allow use with CNOMO, CETOP and ISO. Available up to 100 mm. diameter.

Bore	32	40	50	63	80	100
A	13	17	17	23,5	23,5	/
C - CETOP - ISO (JS 14)	32	36	45	50	63	75
D - CETOP - ISO (JS 14)	7	9	9	9	12	14
E	35	36	45	45	55	56
F	45	52	65	75	95	115
G	30	30	36	35	45	44
H	3,5	3,5	3,5	4,5	5	5
I	7	7	9	9	11	11
M - CNOMO (JS 14)	28	36	45	50	63	73
N - CNOMO (JS 15)	9	9	11	11	13	13
O - CNOMO (JS 15)	32	36	45	50	63	73
O - CETOP - ISO (JS 15)	32	36	45	50	63	73
P - CETOP - ISO (JS 15)	32	36	45	50	63	71
R - CNOMO - ($\pm 0,2$)	27	27	35	35	43	43
L3 - CNOMO	132	171	179	199	207	235
L3 - CETOP - ISO	144	163	175	190	215	230
L4 - CNOMO	134	164	180	195	211	231
L4 - CETOP - ISO	142	161	170	185	210	220
Weight gr.	58	70	118	184	305	385

Large internal and external feet

Ordering code

Internal
1303.Ø.06F
(CNOMO)
(1 piece)
(May be used with
CETOP-ISO
cylinders but are
not specified
in the standards)

External
1303.Ø.07F
(CNOMO)
(1 piece)

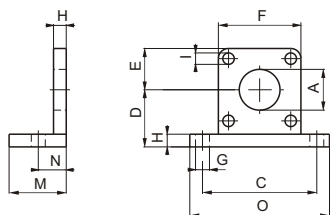
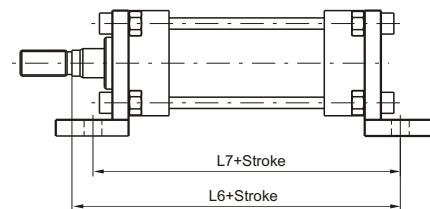
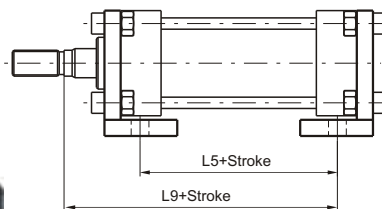

Elements used to anchor the cylinder parallel to the mounting plane. They are made of aluminium alloy and painted black.

Bore	32	40	50	63	80	100	125	160	200
A (H 11)	25	32	32	45	45	55	55	65	65
C (JS 14)	65	72	90	100	126	148	180	230	270
D (JS 15)	32	36	45	50	63	73	91	115	135
E	22	26	32	37	47	57	70	90	110
F	45	52	65	75	95	115	140	180	220
G (H 14)	9	9	11	11	14	14	18	22	22
H	8	8	10	10	12	12	16	20	20
I	7	7	9	9	11	11	13	17	17
M	35	35	45	45	55	55	67	80	80
N ($\pm 0,2$)	18	18	22	22	28	28	32	40	40
O	82	90	110	120	155	180	215	275	315
L5 - CNOMO	60	90	86	101	93	113	113	140	140
L5 - CETOP - ISO	78	90	86	101	104	113	136	140	150
L6 - CNOMO	123	162	166	186	192	220	224	270	270
L6 - CETOP - ISO	141	162	166	186	203	220	247	270	280
L7 - CNOMO	116	146	154	169	181	201	209	260	260
L7 - CETOP - ISO	134	146	154	169	192	201	232	260	270
L9 - CNOMO	95	134	132	152	148	176	176	210	210
L9 - CETOP - ISO	112	128	133	148	162	176	213	240	250
Weight gr.	80	90	190	210	460	600	1080	2400	3100

Front clevis

Ordering code

Front
1303.Ø.08F
(CNOMO)
1304.Ø.08F
(CETOP - ISO)

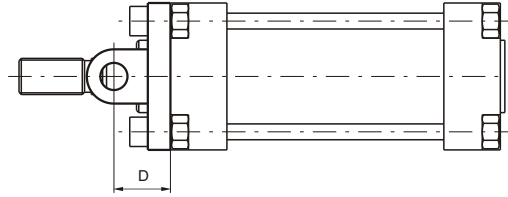
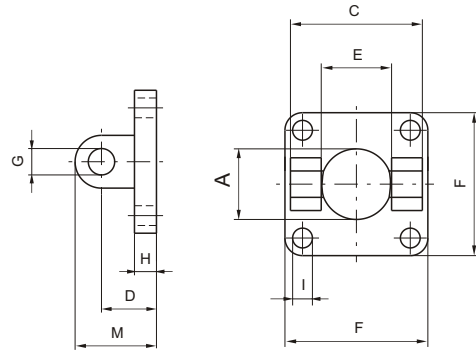

For dimension, see this table

This type of mounting allows anchorage of the cylinder both parallel and at a right angle to the plane; the cylinder rod can oscillate and self-align as necessary. It is made of aluminium alloy and painted black.

Rear clevis complete with pin

Ordering code

Front
1303.Ø.09F
(CNOMO)
1304.Ø.09F
(CETOP - ISO)

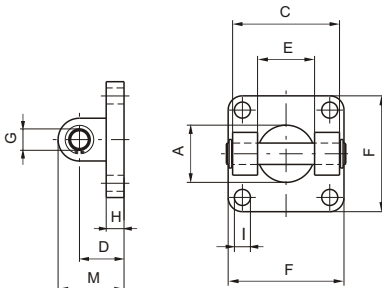
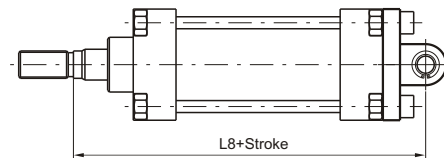

This type of mounting allows anchorage of the cylinder both parallel and at a right angle to the plane; the cylinder rod can oscillate and self-align as necessary. It is made of aluminium alloy and painted black.

Bore	32	40	50	63	80	100	125	160	200
A	25	32	32	45	45	55	55	65	65
C - CNOMO (H 11)	45	52	65	75	95	115	140	180	220
C - CETOP - ISO (H 14)	45	52	60	70	90	110	130	170	170
D - CNOMO (± 0,2)	18	24	26	30	32	37	41	55	55
D - CETOP - ISO (±0,2)	20	22	25	30	32	37	46	55	55
E - CNOMO (H 14)	26	33	33	47	47	57	57	72	72
E - CETOP - ISO (H 14)	26	28	32	40	50	60	70	90	90
F	45	52	65	75	95	115	140	180	220
G - CNOMO (H 9)	8	12	12	16	16	20	20	25	25
G - CETOP - ISO (H 9)	10	12	12	16	16	20	25	30	30
H	8	8	10	10	12	12	16	19	19
I	7	7	9	9	11	11	13	17	17
M - CNOMO	126	36	38	46	48	57	61	80	80
M - CETOP - ISO	30	35	37	46	48	57	71	85	85
L8 - CNOMO	123	168	170	194	196	229	233	285	285
L8 - CETOP - ISO	142	160	170	190	210	230	275	315	335
Weight gr. (Ø8F)	55	60	120	145	325	510	900	2080	3100
Weight gr. (Ø9F)	75	110	190	280	490	820	1270	2800	3900

Rear male clevis

Ordering code

1304.Ø.09/1F
(For CETOP - ISO cylinders .
May be used with CNOMO cylinders but is not specified in the standards)

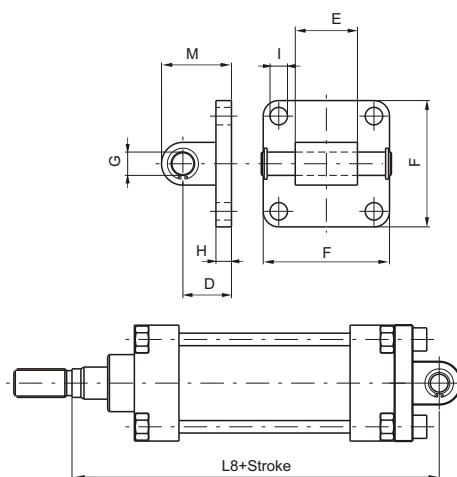

Similar to 09 clevis except for the connection, which is male rather than female. It can also be used as a counter clevis for type 10 (only CETOP - ISO). Allows mounting of cylinder at right angle to the plane of the cylinder rod.

Bore	32	40	50	63	80	100	125	160	200
D (± 0,2)	20	22	25	30	32	37	46	55	55
E (H 14)	26	28	32	40	50	60	70	90	90
F	45	52	65	75	95	115	140	180	220
G (H 9)	10	12	12	16	16	20	25	30	30
H	8	8	8	10	12	12	16	20	20
I	7	7	9	9	11	11	14	18	18
M	30	35	36	45	47	57	71	80	80
L8 - CNOMO	125	166	169	194	196	229	233	285	285
L8 - CETOP - ISO	142	160	170	190	210	230	275	315	335
Weight gr.	50	80	110	185	325	460	1300	2850	3980

Rear clevis bracket

Ordering code

1303.Ø.10F
(CNOMO)
(May be used with CETOP - ISO cylinders but is not specified in the standards)

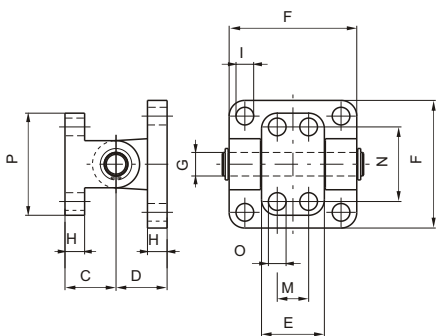
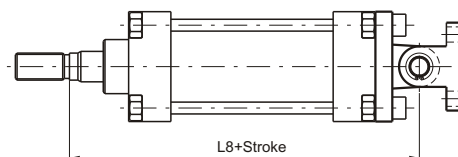

Mounting consists of clevis 09 and counter clevis. Used to mount cylinders at a right angle to the plane to which the counter clevis is attached. Allows self-alignment of the cylinder rod under load with an oscillation of ± 60 degrees.

Bore	32	40	50	63	80	100	125	160	200
C (± 0,2)	180	26	26	34	34	41	41	55	55
D (± 0,2)	18	24	26	30	32	37	41	55	55
E	25	32	32	46	46	56	56	71	71
F	45	52	65	75	95	115	140	180	220
G (H 9)	8	10	10	12	12	16	16	20	20
H	8	10	10	12	12	16	16	20	20
I	7	7	9	9	11	11	13	17	17
M (JS 14)		16	16	25	25	32	32	43	43
N (JS 14)	28	38	38	54	54	90	90	150	150
O (H 13)	7	9	9	11	11	14	14	18	18
P	40	52	52	75	75	115	115	180	180
L8 - CNOMO	123	168	170	194	196	229	233	285	285
L8 - CETOP - ISO	140	162	171	190	210	229	270	315	335
Weight gr.	90	165	240	470	665	1190	1660	3700	4700

Trunnion with support bracket

Ordering code

1303.Ø.11F
(CNOMO)
(May be used with
CETOP - ISO
cylinders but
is not specified
in the standards)

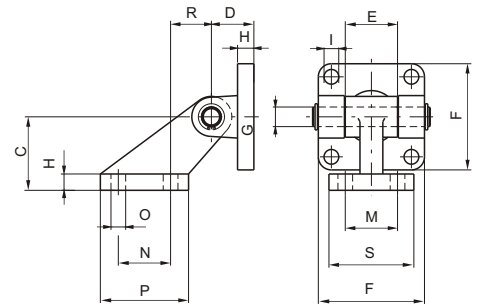
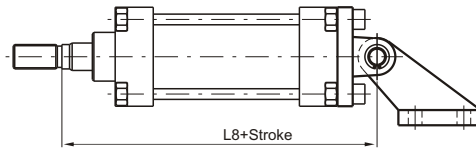

Mounting consists of clevis 09 and right angle counter clevis. Used to mount cylinders parallel to the plane to which the counter clevis is attached. Allows self-alignment of the cylinder rod under load with an oscillation up to 90 degrees from the mounting plane.

Bore	32	40	50	63	80	100	125	160	200
C (JS 15)	32	45	45	63	63	90	90	140	140
D (± 0,2)	18	24	26	30	32	37	41	55	55
E	25	32	32	46	46	56	56	71	71
F	45	52	65	75	95	115	140	180	220
G (H 9)	8	12	12	16	16	20	20	25	25
H	8	10	10	12	12	16	16	20	20
I	7	7	9	9	11	11	13	17	17
M (JS 14)	25	32	32	40	40	50	50	63	63
N (JS 14)	20	32	32	50	50	70	70	110	110
O (JS 13)	7	9	9	11	11	14	14	18	18
P	37	54	54	75	75	102	102	154	154
R	18	25	25	32	32	40	40	50	50
S	41	51	51	62	62	80	80	110	110
L8 - CNOMO	123	168	170	194	196	229	233	285	285
L8 - CETOP - ISO	140	162	171	190	210	229	270	315	335
Weight gr.	125	250	325	600	800	1570	2100	4600	5700

Intermediate trunnion

Ordering code

1300.Ø.12F

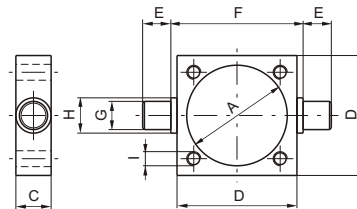
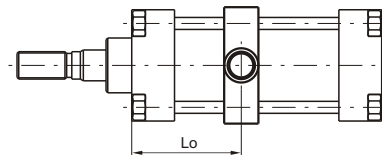

Bore	32	40	50	63	80	100	125	160	200
A	37	46	56	69	87	107	133	170	211
C	15	20	20	25	25	30	32	40	40
D	46	59	69	84	102	125	155	190	240
E (h 14)	12	16	16	20	20	25	25	32	32
F (h 14)	50	63	73	90	108	131	160	200	250
G (e 9)	12	16	16	20	20	25	25	32	32
H	15	20	20	25	25	30	30	40	40
I	M6	M6	M8	M8	M10	M10	M12	M16	M16
Lo min.	32	35	40	47	53	55	61	78	79
Lo max. + stroke - CNOMO	48	75	70	80	72	90	84	103	102
Lo max. + stroke - CETOP - ISO	67	75	70	80	84	90	107	103	112
Weight gr.	130	310	370	700	900	1590	2600	4300	7500

Clevis to be mounted between the endcaps of the cylinder allowing rotation at any point along the barrel. One piece construction from zinc-plated stamped steel. Can be mounted in fixed position or attached to adjustable tie rods.
NOTE: Lo max means at stroke 0.

Fork with pin

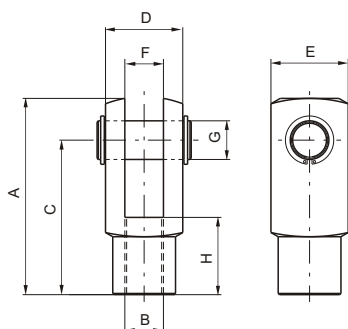

Male fork

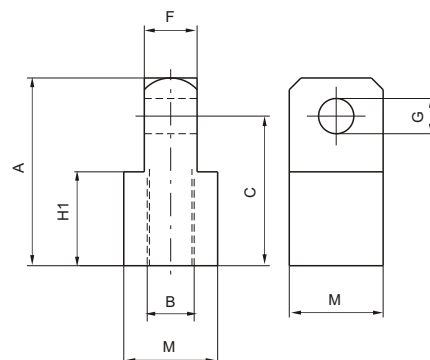

**Fork with clips
from Ø 32 to Ø 100**

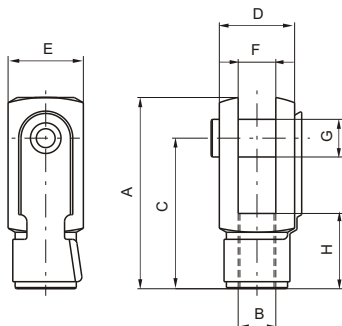

Rod lock nut

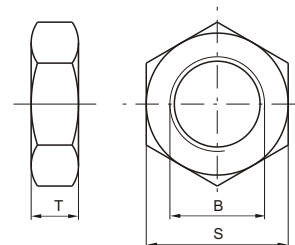

Ordering code	
<i>Fork with pin</i>	
1300.Ø.13F (CNOMO)	
1301.Ø.13F (CETOP)	
1302.Ø.13F (ISO)	
<i>Male fork</i>	
1300.Ø.14F	
(only for CNOMO cylinders)	
<i>Fork with clips</i>	
1300.Ø.13/1F (CNOMO)	
1301.Ø.13/1F (CETOP)	
1302.Ø.13/1F (ISO)	
<i>Rod lock nut</i>	
1300.Ø.18F (CNOMO)	
1301.Ø.18F (CETOP)	
1302.Ø.18F (ISO)	

Bore	32	40	50	63	80	100	125	160	200	
A - CNOMO	45	64	64	80	80	105	105	140	140	
A - CETOP - ISO	51	62	82	82	105	105	132/148	188	188	
B - CNOMO (6H)	M10x1,5	M16x1,5	M16x1,5	M20x1,5	M20x1,5	M27x2	M27x2	M36x2	M36x2	
B - CETOP (6H)	M10x1,25	M12x1,25	M16x1,5	M16x1,5	M20x1,5	M20x1,5	M24x2	M36x2	M36x2	
B - ISO (6 H)	M10x1,25	M12x1,25	M16x1,5	M16x1,5	M20x1,5	M20x1,5	M27x2	M36x2	M36x2	
C - CNOMO	36	51	51	63	63	85	85	115	115	
C - CETOP - ISO	40	48	64	65	80	80	100/100	144	144	
D - CNOMO	22	36	36	45	45	63	63	80	80	
D - CETOP - ISO	20	24	32	32	40	40	50/55	70	70	
E - CNOMO	22	26	26	34	34	42	42	50	50	
E - CETOP - ISO	20	24	32	32	40	40	50/55	70	70	
F - CNOMO (H 14)	11	18	18	22	22	30	30	40	40	
F - CETOP - ISO (B 12)	10	12	16	16	20	20	25/30	35	35	
G - CNOMO (H 9)	8	12	12	16	16	20	20	25	25	
G - CETOP - ISO (H 9)	10	12	16	16	20	20	25/30	35	35	
H - CNOMO	20	26	26	30	30	45	45	75	75	
H - CETOP - ISO	20	24	32	32	40	40	50/56	72	72	
H1 - CNOMO	20	32	32	40	40	55	55	75	75	
M	22	32	32	36	36	45	45	70	70	
S - CNOMO	17	24	24	30	30	41	41	55	55	
S - CETOP	17	19	24	24	30	30	36	55	55	
S - ISO	17	19	24	24	30	30	41	55	55	
T - CNOMO	6	8	8	9	9	12	12	18	18	
T - CETOP	6	7	8	8	9	9	10	18	18	
T - ISO	6	7	8	8	9	9	12	18	18	
Weight: gr.	Fork	90	150	350	350	680	680	2500	4000	4000
	Rod lock nut	10	20	20	35	35	80	80	210	210
	Male forc	110	30	330	500	500	1300	1300	3500	3500

Basic version

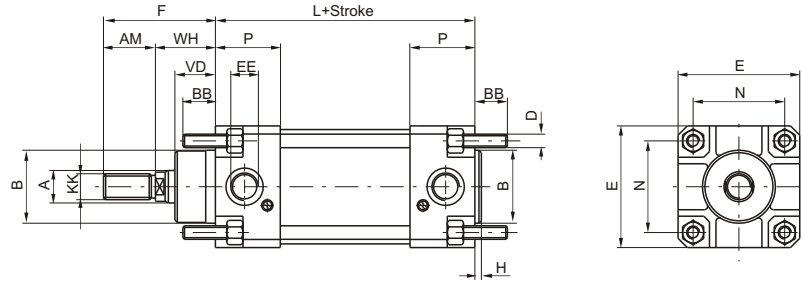

Ordering code

1305.250.stroke.01A (ISO)
non magnetic piston, aluminium barrel
1308.250.stroke.01A (ISO)
magnetic piston, aluminium barrel
VITON® seal version
add "V" to the cylinder code

$\varnothing A$	AM	$\varnothing B$	BB	D	E	EE	F	H	KK	L	N	P	VD	WH
50	84	90	50	M20	270	G1"	189	4	M42x2	200	220	54	65	105

Front and rear flanges

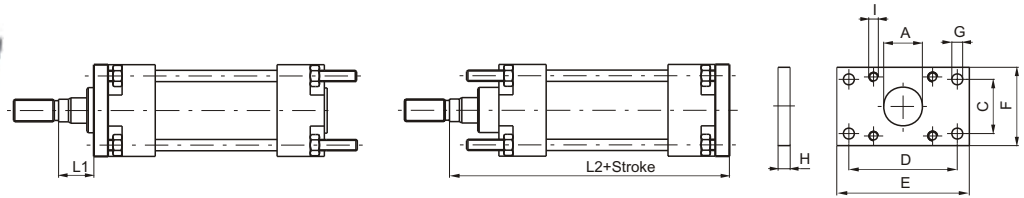

Ordering code

1305.250.03F
front
1305.250.04F
rear

A (H11)	C(JS14)	D(JS14)	E	F	G (JS14)	H (JS14)	I	L1	L2	Weight gr.
90	165	330	400	285	26	25	M20	80	330	1.825

Rear clevis complete with pin

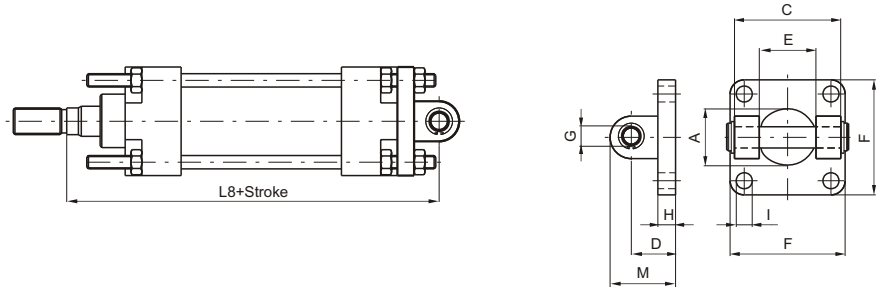

Ordering code

1305.250.09F

A	C(H14)	D(± 0.2)	E(H14)	F	G (H9)	H	I	M	L8	Weight gr.
90	200	70	110	270	40	25	22	112	375	7.800

Rear male clevis

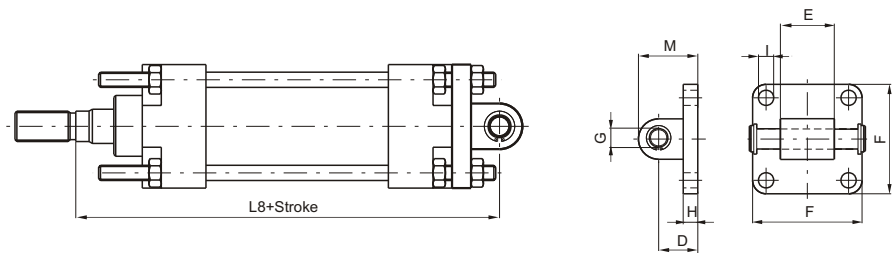

Ordering code

1305.250.09/1F

D(± 0.2)	E(H14)	F	G (H9)	H	I	M	L8	Weight gr.
70	110	270	40	25	22	112	375	8.300

Intermediate trunnion

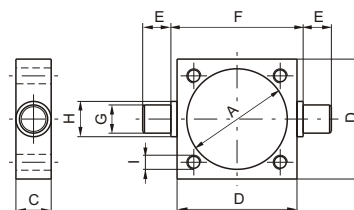
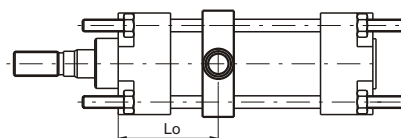

Ordering code

1305.250.12F

A	C	D	E(h14)	F(h14)	G (E2)	H	I	Lo min	Lo max.+stroke	Weight gr.
267	50	296	40	320	40	60	M20	83	117	1.300

Fork with pin

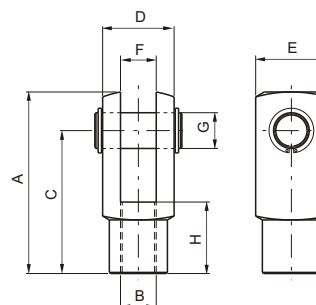

Ordering code

1302.250.13F

A	B(H6)	C	D	E	F(B12)	G(H9)	H	Weight gr.
188	M42X2	144	70	70	35	35	72	3.700

Rod lock nut

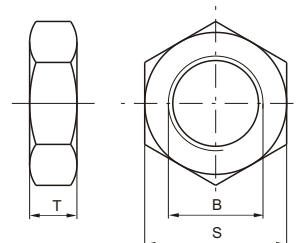

Ordering code

1302.250.18F

B	S	T	Weight gr.
M42x2	65	21	260