

Light, Compact, Easy-to-Uses Tsurumi Typical Portable Pumps, Perfect for a Variety of Applications



Individual Features

Flow-Thru Design

An excellent cooling effect for the motor can be achieved at low water levels. The top discharge port enables the pump to be installed in narrow locations.

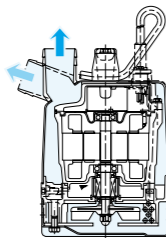

Multi-Directional Hose Coupling

Discharge can be converted to horizontal direction. Notched bolt holes enable the hose coupling to be removed by merely loosening the cap nuts.

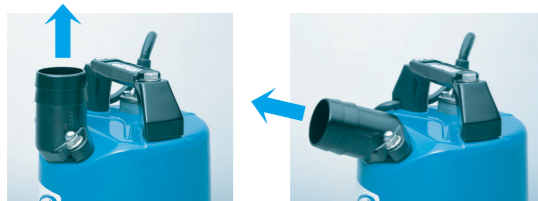

Slimline Models

The non-automatic model has the overall dimension of 187 mm and can fit in a 200-mm (8") casing.

Automatic Operation

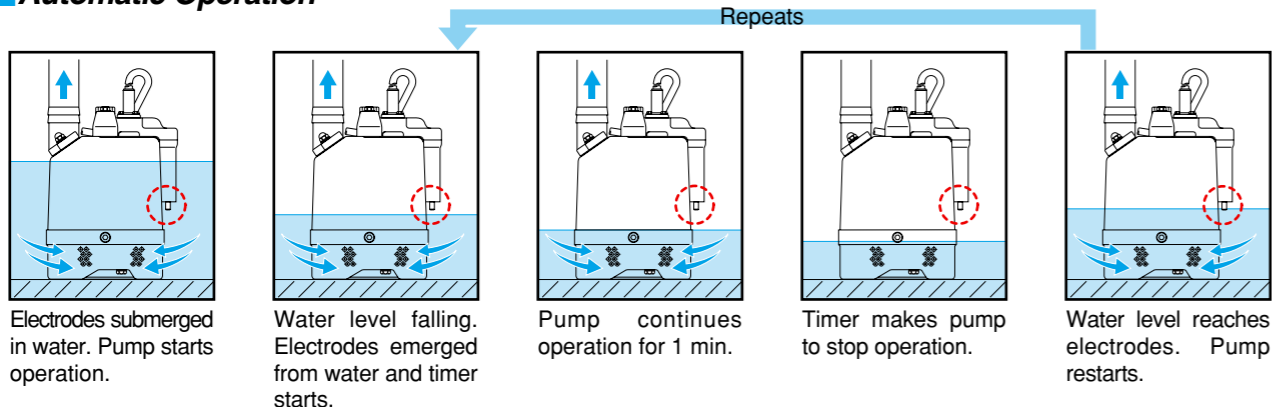

Major Standard Specifications

Discharge Bore		mm	50(80)
Motor Output		kW	0.48 - 0.75
Pumping Fluid	Type of Fluid	Rain, Spring, Ground, Sand Carrying Water	
	Fluid Temperature	0 to 40°C	
Pump	Structure	Impeller	Semi-vortex
		Shaft Seal	Double Mechanical Seal (with Oil Lifter)
		Bearing	Double-shielded Ball Bearing
	Materials	Impeller	Urethane Rubber
		Casing	Synthetic Rubber
		Suction Cover	Carbon Steel + Urethane Rubber
Motor	Type, Pole	Dry Type Submersible Induction Motor, 2-pole	
	Insulation	Class E	
Phase/Voltage	Single-phase/ 110V, 220V, 230V, 240V		
	Starting Method	Capacitor Run	
Protection Device (Built-in)	Miniature Thermal Protector/ Circle Thermal Protector		
	Lubricant	Turbine Oil (ISO VG32)	
Materials	Frame	Aluminium Alloy Die-casting	
	Shaft	403 Stainless Steel	
	Cable	PVC	

Simple Structure

The pump section can be disassembled and reassembled using a single 13-mm box wrench.

Electrode Auto Control Device (LB-A)

Stable electrode-type sensor ON/OFF operation prevents dry running, saves power consumption, and extends operational life.



Performance Curves

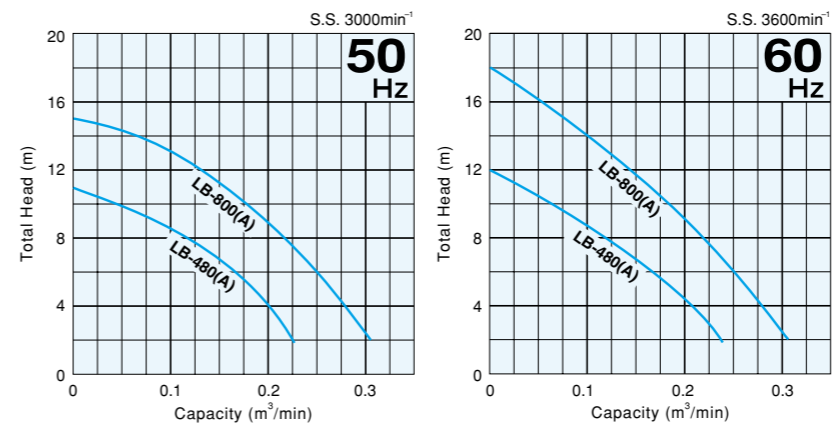

Standard Specifications 50/60Hz

Discharge Bore mm	Model	Motor Output kW	Phase	Starting Method	Dry Weight kgs	Cable Length m	Dimensions mm						C.W.L. mm
							d	A	A1	B	B1	D	
50	LB-480	0.48	Single	Capacitor Run	10.4	5	50	233	162	286	228	187	50
50	LB-480A	0.48	Single	Capacitor Run	11.0	5	50	233	162	286	228	187	115
50(80)	LB-800	0.75	Single	Capacitor Run	13.2	5	50	230	160	337	283	187	50
50(80)	LB-800A	0.75	Single	Capacitor Run	13.8	5	50	230	160	337	283	187	170

● 80 mm discharge available upon request ● Dry weight excluding cable

Dimensions

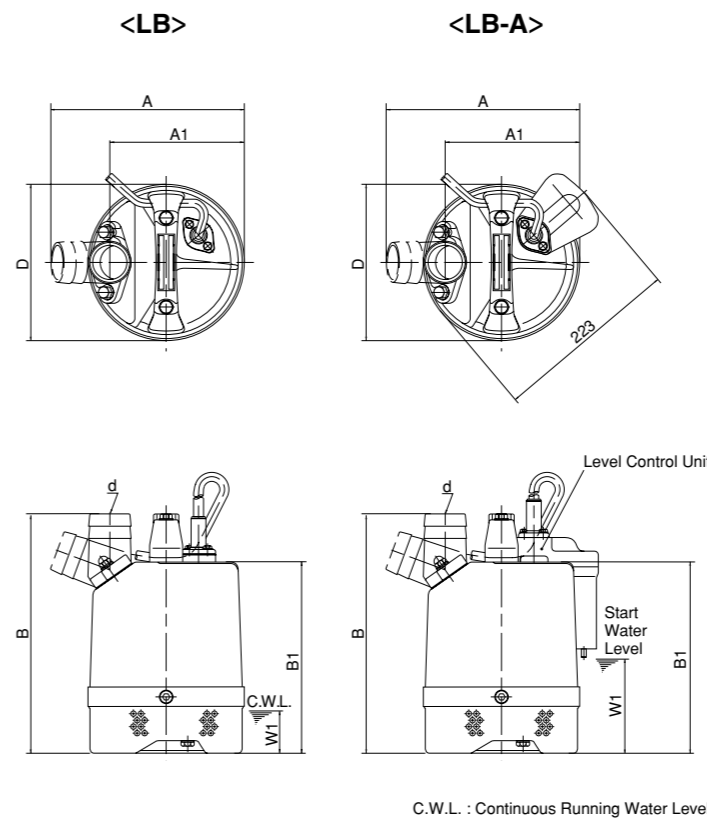

Cross-Section

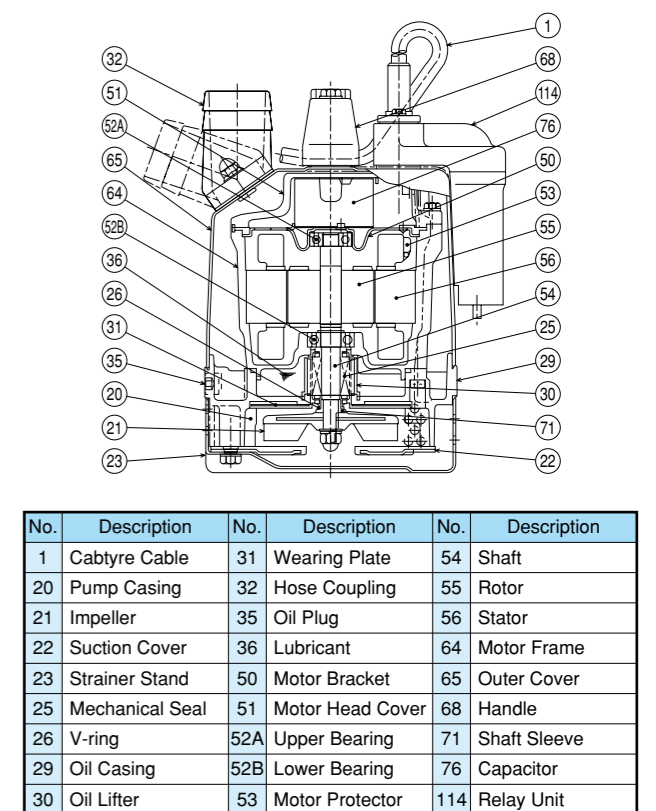

Applications

Draining at civil engineering and building sites
Draining storm water, groundwater, or puddles
Draining from basements or utility pits
Draining water from dewatering wells

Standard Accessories

- Hose Coupling..... 1pc.
- Hose Band..... 1pc.