

**union**<sup>®</sup>  
Industrial Brushes

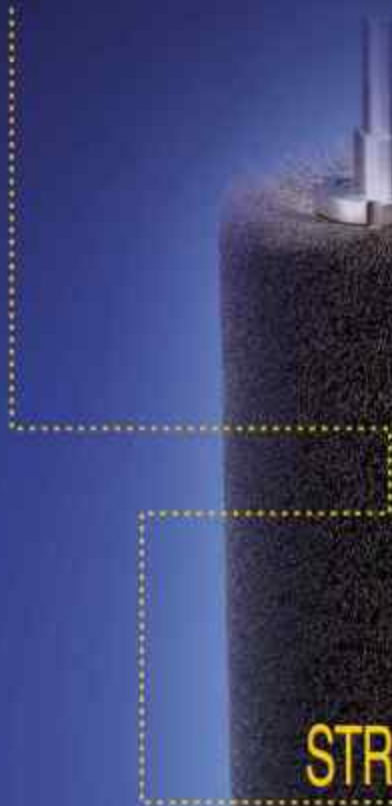

**STRIP & ROLLER Brushes**

板槽刷 & 輪軸刷



### 金屬線材 METAL WIRE

種類 CATEGORY	酸 ACID	鹼 ALKALI	一般溶液 COMMON SOLVENT	耐磨耗性 WEAR RESISTANCE	使用溫度界限 TEMPERATURE EXTREMITY	線徑規格 WIRE DIAMETER	特性 PROPERTIES	用途 APPLICATION
鋼線 (BRIGHT HARD DRAWN STEEL WIRE) 40C 60C 70C 80C	X	○	⊙	⊙	300°C	⊙0.08~1.0	由高碳鋼製成，硬度高，韌性佳。 COLD DRAWN HIGH CARBON STEEL WIRE, GOOD HARDNESS AND FLEXIBILITY.	鐵材的除鏽去漬清洗，銹蝕酸洗後的表面清潔，橡膠製品及較硬材料的表面處理。 DUST REMOVING BEFORE CASTING, SURFACE CLEANING AFTER WELDED AND ACID PICKLING, SURFACE TREATMENT FOR RUBBER PRODUCTS AND SOLID MATERIALS.
鍍銅鋼線 (BRASS PLATED DRAWN STEEL WIRE) 70C	X	○	⊙	⊙	300°C	⊙0.1~1.0	單線，硬度高，彈性佳，抗張力強，耐腐力高。 SINGLE WIRE, HIGH HARDNESS AND FLEXIBILITY, GOOD EXTENSION AND PULL RESISTANCE, GOOD WEAR-RESISTANCE.	
扭轉鍍銅鋼線 (BRASS PLATED STRANDED STEEL WIRE) 70C	X	○	⊙	⊙	300°C	⊙0.45~1.25	由3~5條鋼線束成單股，抗張力與耐腐性特強，斷損率低。 COMBINES 3 - 5 PIECES OF WIRES INTO A STRONG WIRE, EXCELLENT EXTENSION AND PULL RESISTANCE, WILL NOT BREAK EASILY.	
不銹鋼線 (STAINLESS STEEL WIRE) SUS 304 SUS 316	○	⊙	⊙	○	400°C	⊙0.04~0.6	弱磁性 WEAK MAGNETISM	同上，並適用於不銹鋼與鋁製品的研磨及酸、鹼清洗及高溫下使用。 SAME AS ABOVE, IN ADDITION TO GRINDING STAINLESS STEEL AND ALUMINUM PRODUCTS, GOOD IN ACID AND ALKALI SOLVENT AND HIGH TEMPERATURE.
							非磁性 NON MAGNETISM	同上，並適用於海水、鹼性及腐蝕性強之下使用。 SAME AS ABOVE, EXCELLENT USE IN SEA WATER, ACID AND CORRODIBLE SOLVENT.
黃銅線 (BRASS WIRE)	△	○	⊙	△	200°C	⊙0.08~0.4	線性柔軟 VERY SOFT WIRE	銅製品及較軟材料的表面研磨。 SURFACE GRINDING FOR BRASS PRODUCTS AND SOFT STUFF.
磷青銅線 (PHOSPHOR-BRONZE WIRE)	△	○	⊙	○	200°C	⊙0.12~0.3	耐磨耗性高 GOOD WEAR-RESISTANCE.	適用於磨管之清潔。 SUITABLE FOR CLEANING GUNS AND ARTILLERY TUBES.

### 化學纖維 CHEMICAL FIBER

種類 CATEGORY	酸 ACID	鹼 ALKALI	有機溶液 ORGANIC SOLVENT	耐磨耗性 WEAR RESISTANCE	軟化點 SOFTENED POINT	使用界限 EXTREMITY	線徑規格 WIRE DIAMETER	特性 PROPERTIES	用途 APPLICATION
尼龍線 NYLON 6 NYLON 66 NYLON 610 NYLON 612	X	○	○	⊙	180°C 210°C 180°C 180°C	100°C 110°C 100°C 100°C	0.1~1.5 0.1~1.5 0.07~1.0 0.07~1.0	具有彈性、柔軟性、耐磨性、無切割性。 FLEXIBLE, SOFT, WEAR RESISTANT AND NO CUTTING EFFECT.	清潔、清洗用、製紙、紡織、玻璃板、乾機、洗車、農產品清洗等。 CLEAN AND WASH PAPER MAKING MACHINE, WEAVING MACHINE, GLASS BOARD MAKING MACHINE, DRYER, CAR WASHING MACHINE AND AGRICULTURAL PRODUCTS.
P.P.線 (POLYPROPYLENE)	⊙	○	○	○	150°C	80°C	⊙0.1~2.0	彈性佳、彎曲回彈性強、吸水率低、適合蒸餾，使用時頭部能呈垂直狀的支撐。 GOOD FLEXIBILITY, LOW WATER ABSORPTION RATE, GOOD FOR USE IN WET CONDITION. THE HEAD PART CAN BE SEPERATED VERTICALLY WHITE USING.	冷軋鋼板的清洗、洗車機、農產品清洗機、紡織機、染整機等。 CLEAN AND WASH PAPER MAKING MACHINE, WEAVING MACHINE, AGRICULTURAL PRODUCTS WASHING MACHINE, WEAVING MACHINE AND DYEING MACHINES.
P.V.C.線 (POLYVINYL CHLORIDE)	○	○	△	△	80°C	60°C	⊙0.1~2.0	耐酸鹼、耐濕熱，不過電阻及海鹽。 ACID AND ALKALI RESISTANT, NOT GOOD AT RESISTING HIGH TEMPERATURE AND HUMIDITY.	清潔用及鍍金品、塗裝品、皮革品、木製品、樹脂品的表面加工等。 GOOD FOR CLEANING AND PROCESSING THE ELECTRONIC-PLATING ITEMS, COATING ITEMS, LEATHER PRODUCTS, CARPENTRY PRODUCTS AND RESIN PRODUCTS.
磨粉砂之尼龍研磨線 (ABRASIVE NYLON FILAMENTS)								以尼龍612為基材與碳化矽或氧化鋁的研磨粒相成的線材，磨過各種凹凸不平的表面研磨。 MADE OF EXTRUDED 612 NYLON BASE INTERSPERSED WITH EITHER SILICON CARBIDE OR ALUMINUM OXIDE GRIT, SUITABLE FOR USE ON IRREGULAR SURFACES.	冷軋鋼板、印刷電路板的表面研磨、洗淨、酸洗後的清洗、熱處理後的精確清除、木工傢俱的細磨及大理石地面的清潔等。 GRINDING COLD ROLLED STAINLESS STEEL SHEET, PRINTED CIRCUIT BOARD, CARPENTRY PRODUCTS AND CLEANING THE CARBIDE AFTER ACID PICKLING AND HEAT TREATMENT.
(碳化矽) 612 SILICON CARBIDE	X	○	○	⊙	180°C	100°C	⊙0.45~1.2		
(氧化鋁) 612 ALUMINUM OXIDE	X	○	○	⊙	180°C	100°C	⊙0.45~1.2		

### 動、植物纖維 NATURAL FIBER

種類 CATEGORY	酸 ACID	鹼 ALKALI	有機溶液 ORGANIC SOLVENT	耐磨耗性 WEAR RESISTANCE	使用溫度界限 TEMPERATURE EXTREMITY	線徑規格 WIRE DIAMETER	特性 PROPERTIES	用途 APPLICATION
豬毛 (HOG BRISTLES)	△	X	○	⊙	100°C	約 ⊙0.25	高耐熱性，對酸、鹼會起老化現象，抗靜電性弱。 GOOD HEAT-RESISTANCE, WILL BECOME SENILE WITH ACID AND ALKALI MATERIAL, GENERATE WEAK STATIC ELECTRICITY.	洗淨、磨光、拋光用。 CLEANING, BRUSHING AND POLISHING.
馬毛 (HORSE HAIR)	△	X	○	○	100°C	約 ⊙0.18		
山羊毛 (GOAT HAIR)	△	X	○	△	100°C	約 ⊙0.08		
白藤 (TEMPICO FIBER)	X	△	○	△	100°C	約 ⊙0.2	植物纖維，適用於掃除用。 A PLANT FIBER, SUITABLE FOR SWEEPING AND CLEANING.	洗淨及清掃用，木器的表面拋光。 CLEANING, SWEEPING AND CARPENTRY PRODUCT POLISHING.

## U型板槽刷的構造

## CHANNEL STRIP BRUSHES

### CHANNEL MATERIAL

- 1.軟鋼帶 GALVANIZED
- 2.不銹鋼帶 STAINLESS STEEL
- 3.鋁帶 ALUMINUM

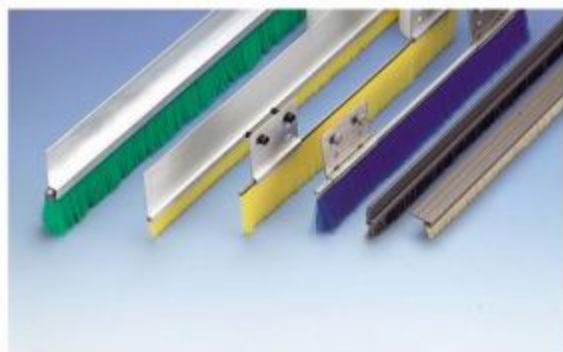
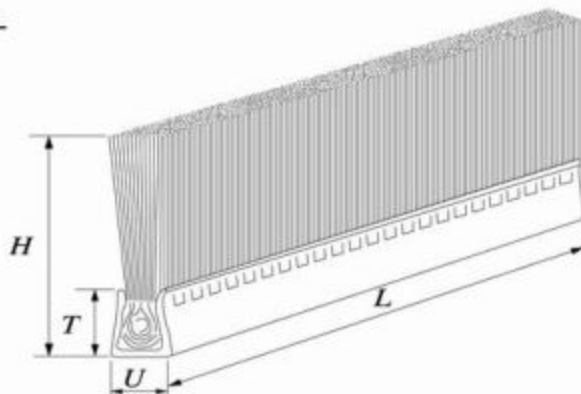

■ U型板槽刷標準規格表 METAL CHANNEL STRIP SIZE

CHNO.	U (mm)	T (mm)	L
U-3	3.5	4	Free
U-4	4	4.5	
U-5	5	5.5	
U-6	6	7	
U-7	7	8	
U-8	8	9	
U-10	10	11	
U-12	12	13	
U-14	14	15	



#### 板槽刷固定槽-H型 BACKING STRIP- H TYPES

鍍鋅鐵板固定槽使用於：  
U-6, U-8, U-10, U-12.

ZIN PLATED STEEL STRIP FOR:  
U-6, U-8, U-10, U-12.



#### 板槽刷固定槽-J型 BACKING STRIP- J TYPES

不銹鋼固定槽使用於：  
U-4, U-6, U-8.

STAINLESS STEEL STRIP FOR:  
U-4, U-6, U-8.



#### 板槽刷固定槽-I型 BACKING STRIP- I TYPES

鋁板固定槽使用於：U-4, U-8.  
塑膠固定槽使用於：U-4.

ALUMINUM STRIP FOR: U-4, U-8.  
PLASTIC STRIP FOR: U-4.



#### 板槽刷固定槽-L型 BACKING STRIP- L TYPES

鋁板固定槽使用於：U-4.  
塑膠固定槽使用於：U-4.  
不銹鋼固定槽使用於：U-4, U-6, U-8.

ALUMINUM STRIP FOR: U-4.  
PLASTIC STRIP FOR: U-4.  
STAINLESS STEEL STRIP FOR:  
U-4, U-6, U-8.

## TYPES 100 密捲中軸型

## SPIRAL ROLLER BRUSHES-CLOSED FACE



■  $D \times AH \times A \times L \times AL$

CHNo. x FILLING

■  $D \times AH \times A \times L \times AL$

CHNo. : 板槽尺寸 x 線材

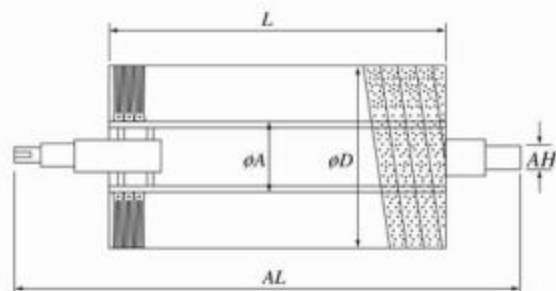

## TYPES 150 密捲中孔型

## SPIRAL ROLLER BRUSHES-CLOSED FACE



■  $D \times AH \times A \times M \times L$

CHNo. x FILLING

■  $D \times AH \times A \times M \times L$

CHNo. : 板槽尺寸 x 線材

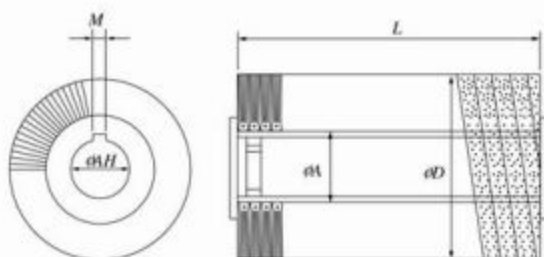

## TYPES 200 間捲單向螺旋型

## SPIREL ROLLER BRUSHES-OPEN FACE



■  $D \times A \times L \times AL$

CHNo.  $\times P \approx x$  FILLING

■  $D \times A \times L \times AL$

CHNo. : 板槽尺寸  $\times P \approx$  間隔尺寸  $\times$  線材

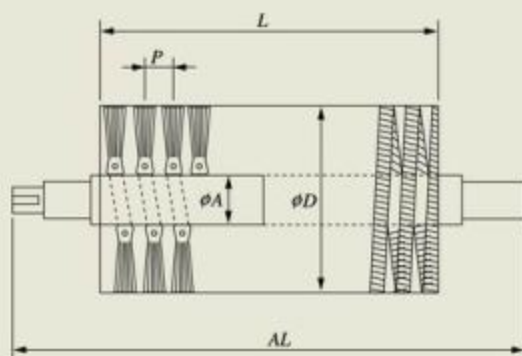

## TYPES 250 間捲雙向螺旋型

## SPIRAL ROLLER BRUSHES-OPEN FACE



■  $D \times A \times L \times AL$

CHNo.  $\times P \approx x$  FILLING

■  $D \times A \times L \times AL$

CHNo. : 板槽尺寸  $\times P \approx$  間隔尺寸  $\times$  線材

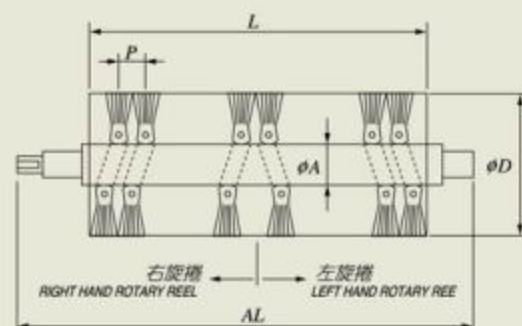

## TYPES 300 插軌固定型

## STRIP ROLLER BRUSHES MOUNTED ON ALUMINIUM CHANNELED TUBULAR CORE



- TYPES<sub>NO.</sub> x D x A x L x FILLING
- ALUMINIUM SHAFT IN 3 SIZES CAN BE PLANTED WITH THE FILAMENTS AND MOULDED THE BOARD. CONNECTED SHAFT IS OUR PATENTED DESIGN WHICH CAN BE EXTENDING UNLIMITEDLY.

- TYPES<sub>NO.</sub> x D x A x L x 線材
- 三種尺寸鋁製軸心可供刷毛板帶插植成型，專利連接軸構造，可無限延伸總長度。  
專利號碼：098111



● 連接軸圖示 THE SKETCH OF CONNECTED SHAFT

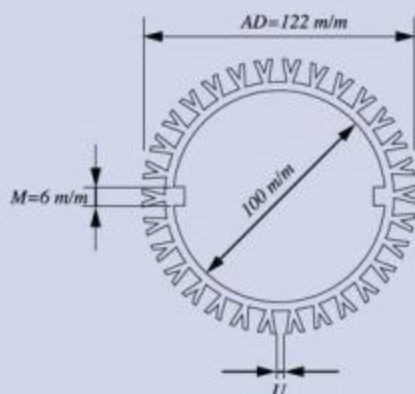
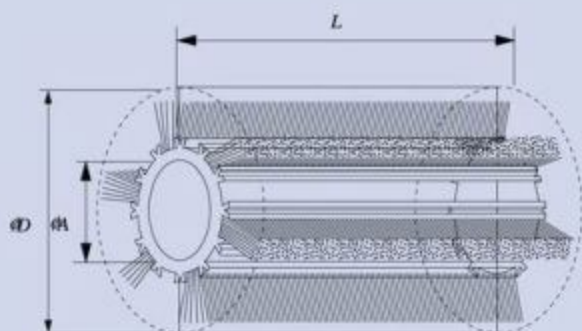

### TYPES : 330

- U = CH<sub>NO.</sub> 8 x 30
- AD = 122 m/m
- A = 100 m/m
- M = 6 m/m

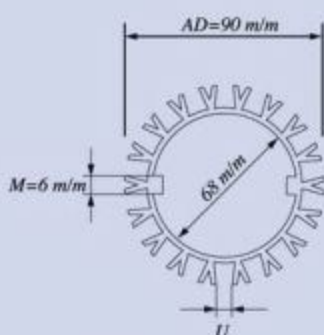

### TYPES : 318

- U = CH<sub>NO.</sub> 8 x 18
- AD = 90 m/m
- A = 68 m/m
- M = 6 m/m

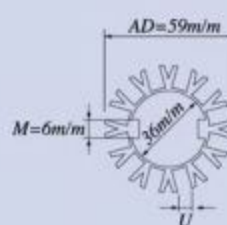

### TYPES : 312

- U = CH<sub>NO.</sub> 8 x 12
- AD = 59 m/m
- A = 36 m/m
- M = 6 m/m

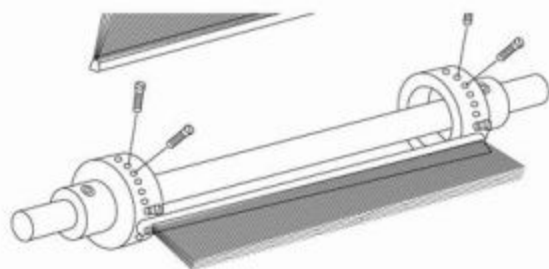
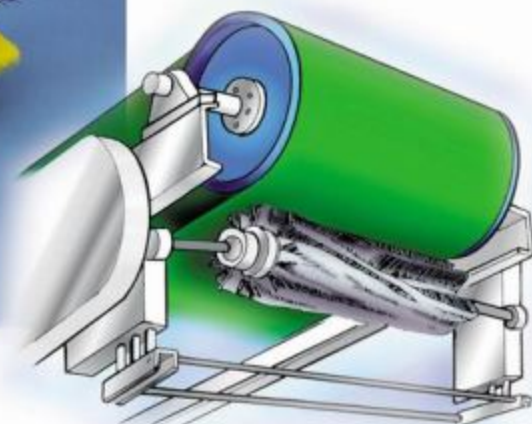

CHNO. : U8 x LINESAGES x FILLING

BRUSH FILAMENTS ARE CHANGEABLE,  
MOST SUITABLE FOR CONVEYER.

D x A x AD x L x AL

CHNO. : 板槽規格=U8 x 排數 x 線材

可換式刷毛，最適合輸送帶清潔用。

專利號碼：60358

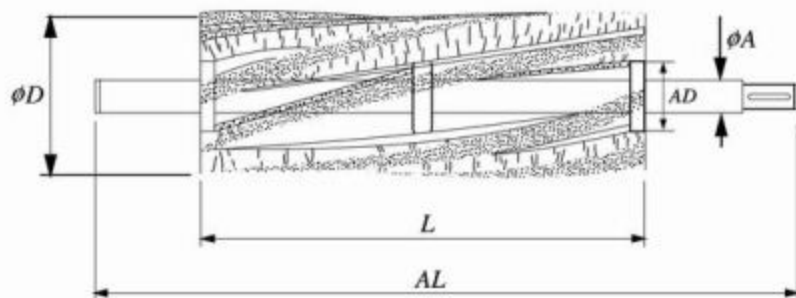

## TYPES 450 螺絲固定雙向螺旋型

## STRIP ROLLER BRUSHES



- $D \times A \times AD \times L \times AL$   
CHNo. : U8 x LINAGES x FILLING
- BRUSH FILAMENTS ARE CHANGEABLE, SCREW FIXED, WITH 2-WAY ROTARY FUNCTION.

- $D \times A \times AD \times L \times AL$   
CHNo. : 板槽規格=U8 x 排數 x 線材
- 可換式刷毛、螺絲固定、雙向螺旋

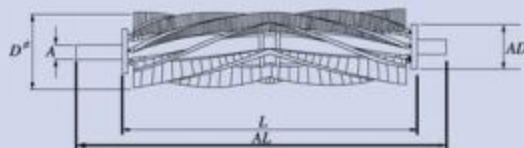

## TYPES 950 片裝軸刷

## SINGLE SECTION ROLLER BRUSHES



- $D \times A \times AD \times AL \times FILLING$
- $D \times A \times AD \times AL \times$  線材

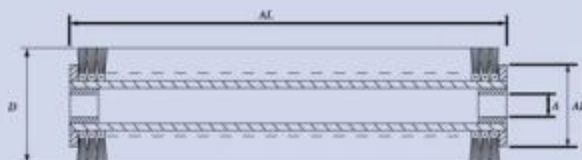



## TYPES 500 内捲空心型

## COIL WOUND BRUSHES, INWARDS



- D x A x L  
CHNo. x FILLING
- SUITABLE FOR SCRUBBING AND POLISHING  
THE OUTER SURFACE OF WIRE ROD AND BAR.

- D x A x L  
CHNo. 板槽尺寸 x 線材
- 適用於線材、圓棒等外周的刷磨。

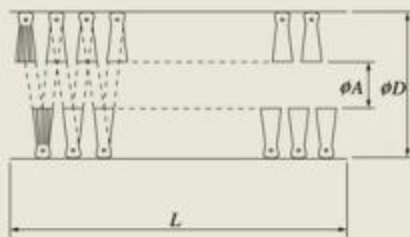

## TYPES 550 外捲空心型

## COIL WOUND BRUSHES, OUTWARDS



- D x A x L  
CHNo. x FILLING

- D x A x L  
CHNo. 板槽尺寸 x 線材



## TYPES 600 內捲單片型

### RING INWARDS

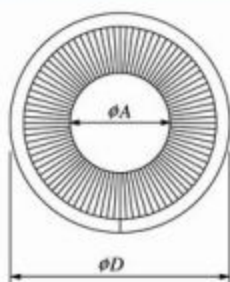

- D x A  
CHNo. x FILLING  
CAN BE USED FOR SCRUBBING  
AND POLISHING THE OUTER  
SURFACE OF WIRE ROD AND BAR.
- D x A  
CHNo. 板槽尺寸 x 線材  
線材、圓棒等外周捲磨及刷磨用

## TYPES 650 外捲單片型

### RING OUTWARDS

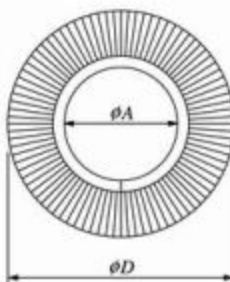

- D x A  
CHNo. x FILLING
- D x A  
CHNo. 板槽尺寸 x 線材

## TYPES 660 下捲單片型

### RING DOWNWARDS

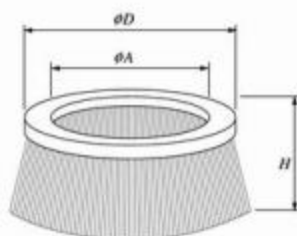

- D x A x H  
CHNo. x FILLING
- CAN BE USED FOR VACUUM  
CLEANING EQUIPMENT AND  
MACHINERY DUST-PROOF  
PURPOSE.
- D x A x H  
CHNo. 板槽尺寸 x 線材
- 吸塵設備及機械防塵用

## TYPES 700 密捲管刷型

### STRIP WOUND PIP BRUSHES - FOR HEAVY DUTY

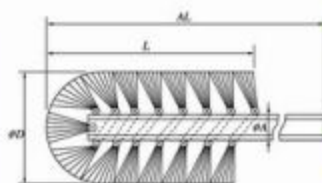

- D x A x L x AL  
CHNo. x FILLING
- CAN BE USED TO HEAVY-GRIND  
THE BOTTOM OR INNER TUBE AND  
INNER HOLE.
- D x A x L x AL  
CHNo. 板槽尺寸 x 線材
- 管内與穴內及底部重研磨用

### 動力輪刷系列 POWER BRUSH SERIES



### 矽砂尼龍研磨刷系列 ABRASIVE NYLON BRUSH SERIES



### 輪軸刷系列 ROLLER BRUSH SERIES



### 板槽刷系列 STRIP BRUSH SERIES



**ACTION TOOL (M) SDN. BHD.** (226014-X)  
(Formerly known as Action Tool Products Sdn. Bhd.)

*ready for action*

Address: 86-3, Jalan Pahang, Setapak, 53000 Kuala Lumpur, Malaysia.

Tel: +603 - 4023 1881 Fax: +603 - 4023 1887

e-mail: action\_tool@yahoo.com, website: www.meehuat.com.my