

# NEW LOW-COST, HIGH-PRECISION POWER QUALITY, ENERGY & ENVIRONMENT MONITORING

## PQube<sup>®</sup> 3

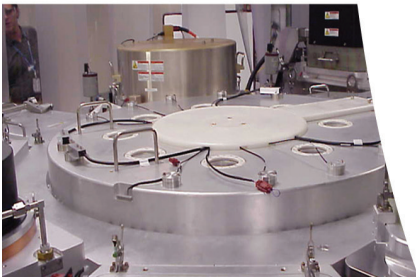
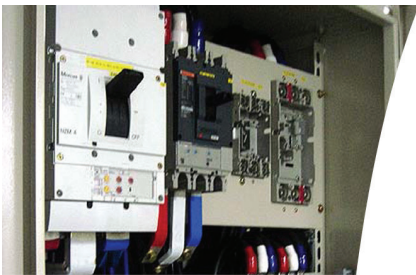

POWER QUALITY CLASS A

ENERGY REVENUE GRADE CLASS 0.2S ACCURACY

ADDITIONAL AC, DC, AND ENVIRONMENT SENSOR CHANNELS

WORLD'S SMALLEST & MOST ADVANCED PMU MICRO SYNCHROPHASOR



## General

- Three-phase, single-phase and split-phase monitoring 69~480V L-N, 100~960V L-L, 50/60/400Hz. No PTs required.
- 8 current channels.
- Self-configuration\*—auto-detects single-phase and multi phase voltage, nominal voltage, nominal frequency.
- Four analog inputs, one digital input, one relay output.
- Optional (up to two) advanced environmental probes.
- Powers from 24 VAC, 24~48VDC, PoE (Power over Ethernet) or 100~240 VAC with PM1 plug-in module.
- Optional UPS plug-in module with 30 minutes of backup power.
- Data storage on internal 8GB solid state memory
- Removable 8GB micro-SD card and USB (optional), with lockable cover for restricted access.
- Color touch screen display, can be operated with safety gloves on!
- DIN-rail or optional panel mount.

## Power Quality Monitoring Class A Ed 3

- Certified Class A IEC 61000-4-30 Ed 3.
- High-speed 512-samples-per-cycle recording.
- Power quality disturbance recording with waveform and RMS graph output.
- Voltage sags, swells and interruptions; over-frequency and under-frequency events, time-triggered snapshots.
- Voltage THD, current TDD and current THD; voltage and current unbalance; VARs; VAR-hr accumulator; flicker (Pinst, PST, PLT).
- Voltage and current harmonics and interharmonics—up to the 63rd, with statistics\*.
- Daily, weekly, monthly trends. Cumulative probability\*, histograms\*, and more.
- Rapid Voltage Changes (RVC).

### Above and Beyond Class A

- Waveshape change triggers and recording.
- 1 Mhz high frequency impulse detection and recording\* (up to 4Mhz on a single channel\*).
- 2kHz-150kHz frequency band measurements.

## Energy (Revenue Class 0.2s Accuracy)

- Available with PSL custom high-precision current transformers to meet the requirements of IEC 62053-22 Class 0.2s and ANSI C12.20 Class 0.2.
- Watts, VA, VARs, True Power Factor, watt-hours, VA-hours, VAR-hours.
- Bi-directional power - received and delivered\*
- Peak averages—single-cycle, 1-minute, 15-minute, and at user-selected intervals.
- CT ratios support from 1:1 up to 1:50000; PT ratios support up to 1:10000 (6,900,000) volts.
- Daily, weekly, monthly trends; load duration curves.
- Energy accumulators—daily, weekly, monthly.

## Environmental Monitoring

- Optional (up to two) Advanced temperature-humidity-atmospheric pressure-acceleration probes PLUS:
  - two ports for solar irradiance (W/m<sup>2</sup>) probe, K-Type thermocouple, etc...
- Analog inputs— suitable for flow, RPM, fluid, pressure, etc...

## Communication (Embedded Ethernet)

- NO SOFTWARE REQUIRED
- Instant email notification after a power quality disturbance or end of trend interval. Free email account.
- Direct remote access to built-in web server.
- Access to the data files through FTP.
- Embedded Ethernet port.
- 2 USB 1.0 ports, 1 USB 2.0 port for data transfer to thumb drives.
- Real time meters with Modbus-TCP and SNMP (v2 and v3).
- NTP and SNTP for clock synchronization.
- Secure encrypted communication with HTTPS.
- IEC 61850\*

\* coming soon with a firmware upgrade



PQube 3 Rear Terminals  
(PQube 3-PQ-E08N)

Actual  
Size



PQube 3 Front Terminals

## Power Supply Modules



### PM1 Power Management module (Part Number PM1)

- Powers the PQube 3 in the voltage range from 100V~240VAC 50/60 Hz or 120~300VDC
- Optional 24VDC output for accessories (up to 10W).

Note: PQube 3 powers from 24VAC, 24VDC~48VDC, or PoE (Power over Ethernet) without additional modules

### UPS1 Power Storage module (Part Number UPS1)

- Configurable battery backup up to 30 mins— allows backup optimization for multiple outage situations
- Includes backup of optional PM1 outputs
- UPS operation and Charging LED indicators

## Environment and Advanced Environment Sensors



PQube 3 connects Environment Sensors through 2 of its USB connectors

### ENV1 EnviroSensor™ (Part number ENV1)

- Monitors ambient temperature, humidity, and barometric pressure
- Temperature/Humidity event triggers
- Use sensors for local/remote ambient temperature/humidity and detection of clogged filters, failed fans.. using up to 10-meter extension cables.
- Temperature accuracy: Typical:  $\pm 0.5^{\circ}\text{C}$
- Humidity accuracy: Typical:  $\pm 5\% \text{RH}$  (20~80% R.H.)

### ENV2 Advanced EnviroSensor™ (Part number ENV2)

ENV1 EnviroSensor™ benefits PLUS:

- 3 axis X-Y-Z accelerometer (reports in  $\text{m/s}^2$ )
- port for K-type thermocouple input
- port for solar irradiance sensor input (reports light illumination in  $\text{W/m}^2$ )

## GPS Time Synchronization / Micro Synchrophasor ( $\mu\text{PMU}$ )



### GPS Time Synchronization

- 1 microsecond time accuracy

### Micro Synchrophasor

- Only the PQube 3 can measure millidegree phase shifts needed for distribution applications
- Developed by the U.S. ARPA-E program for diagnosing Smart Grid and Distributed Generation stability
- Contact PSL for availability and more information

# PQube® 3 AT A GLANCE

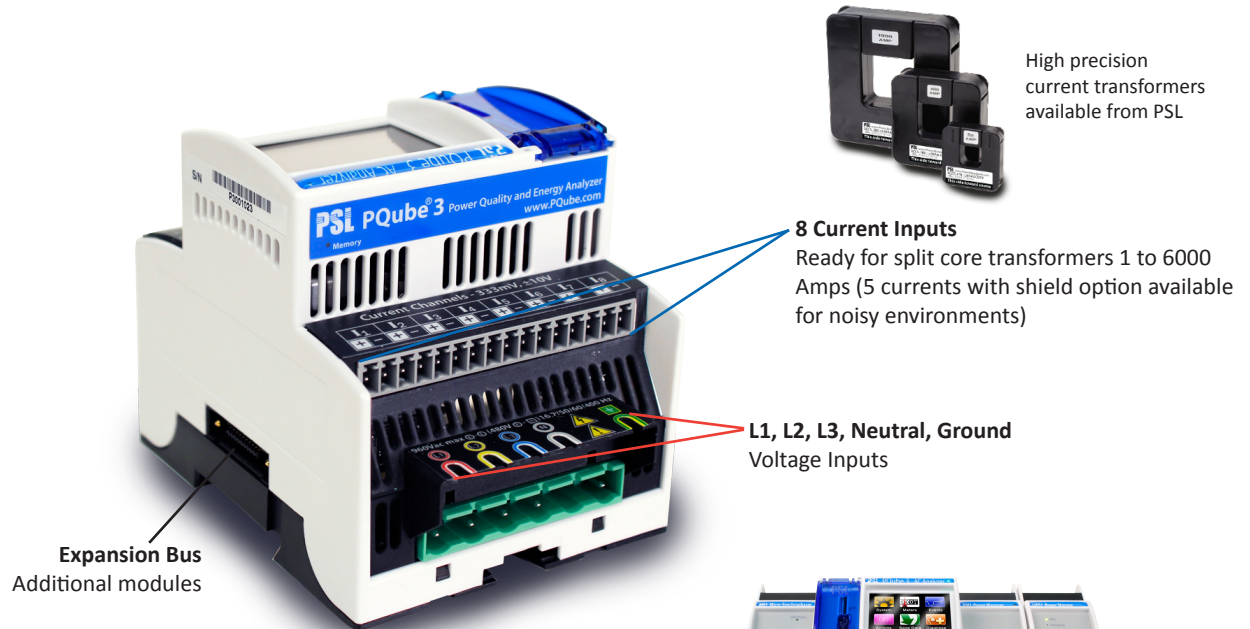
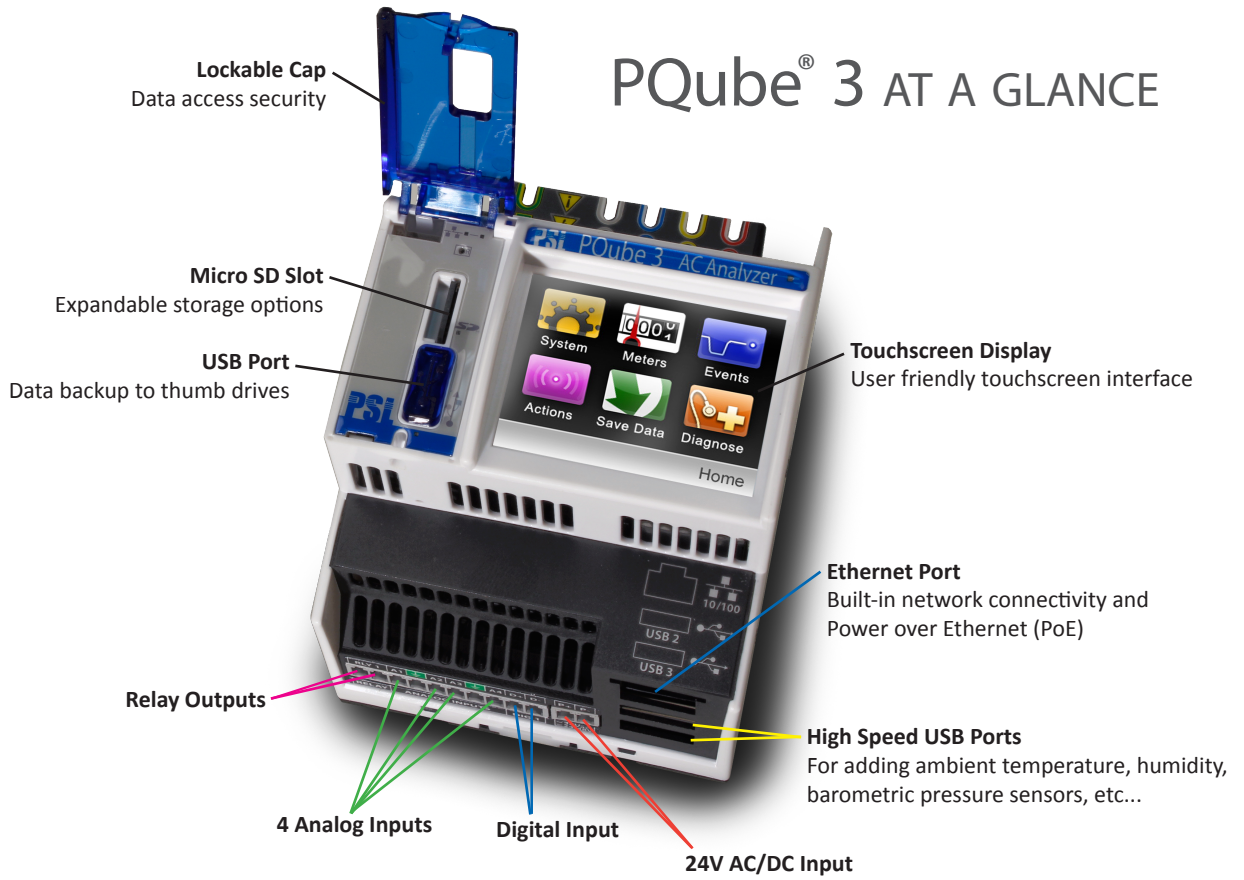

**PQube 3 with plug-in Sync Module, Power Supply and UPS**

## PQube File Formats

Your PQube 3 provides data in several useful formats.

- Events, trends, and statistics as universal .GIF images and .CSV data files
- Text, XML and HTML summaries
- PQDIF files (IEEE standard for power quality data files)

Each graph and chart is labeled in your choice of two languages (35 languages total\*).

All graphs are generated by your PQube 3, without software, and can be viewed in a browser or opened in any picture viewer. They are included in event notification emails as simple .GIF file attachments, and can be forwarded to a third party, such as a facility engineer or utility company.

\* coming soon with a firmware upgrade

PQube® 3
PQube B-4 - Bldg 90 - Panel 90A - Brkr 9 AC24,25,28,43,44  
LBNL Bldg 90 Energy Monitoring Project  
Environmental Energy Technologies Division - BTD

Status	
Meters	PQube 3 Information
Events	
Trends and Statistics	<p><i>Location:</i> Bldg 90 - Panel 90A - Brkr 9 AC24,25,28,43,44</p> <p><i>PQube ID:</i> PQube B-4</p> <p><i>Note 1:</i> LBNL Bldg 90 Energy Monitoring Project</p> <p><i>Note 2:</i> Environmental Energy Technologies Division - BTD</p> <p><i>PQube Serial Number:</i> P3001234</p> <p><i>Model Number:</i> PQube3-PQ-E08N-0000</p> <p><i>Firmware Version:</i> 3.1.11.14.5.21</p> <p><i>IP Address:</i> 128.3.13.188</p>
Command	
Display	
	Configuration
	<p><i>Power Configuration:</i> Wye/Star</p> <p><i>Nominal Line-to-Neutral Voltage:</i> 277V</p> <p><i>Nominal Line-to-Line Voltage:</i> 480V</p> <p><i>Nominal Frequency:</i> 60Hz</p> <p><i>Current Transformer Ratio:</i> 1799:1</p>
	PQube Time
	<p><i>Date:</i> 2014/06/24</p> <p><i>Day of Week:</i> Tuesday</p> <p><i>Time:</i> T 11:34:43 PST</p>

NO SOFTWARE REQUIRED

The PQube 3 web interface access screen. From here, you can check your PQube status, access meters, view events, and send commands. Each PQube can be labeled with a unique name and location, making it easy to monitor multiple PQubes.

Overview of PQube 3 meters screen. Meters refresh every second. ▶

## NO SOFTWARE REQUIRED

### Meters

Meter	Value	
L1-N	286.10 V	
L2-N	285.71 V	
L3-N	285.85 V	
N-E	0.14 V	
L1-L2	494.49 V	
L2-L3	495.05 V	
L3-L1	495.93 V	
L1 Amp	2.88 A	
L2 Amp	4.94 A	
L3 Amp	9.89 A	
N Amp	0.00 A	
E Amp	0.01 A	
DIG1	0	
Frequency	59.982 Hz	
L1 Flicker	<i>P<sub>inst</sub></i>	0.00
	<i>P<sub>ST</sub></i>	0.01
	<i>P<sub>LT</sub></i>	---.--
L2 Flicker	<i>P<sub>inst</sub></i>	0.00
	<i>P<sub>ST</sub></i>	0.01
	<i>P<sub>LT</sub></i>	---.--
L3 Flicker	<i>P<sub>inst</sub></i>	0.00
	<i>P<sub>ST</sub></i>	0.01
	<i>P<sub>LT</sub></i>	---.--

### Class A Meters

Class A Meters	Value
Max 2kHz-9kHz	0.06 V @ 4 kHz
Max 8kHz-150kHz	0.05 V @ 126.0 kHz

### ENV\_A

External Probes	Value
Temperature	22.3 degC
Humidity	35.6 %RH

### ENV\_B

External Probes	Value
Temperature	31.8 degC
Humidity	23.4 %RH

Data from the PSL PQube® 3 by [www.PowerSensorsLtd.co](http://www.PowerSensorsLtd.co)

# Great PQube 3 Graphs

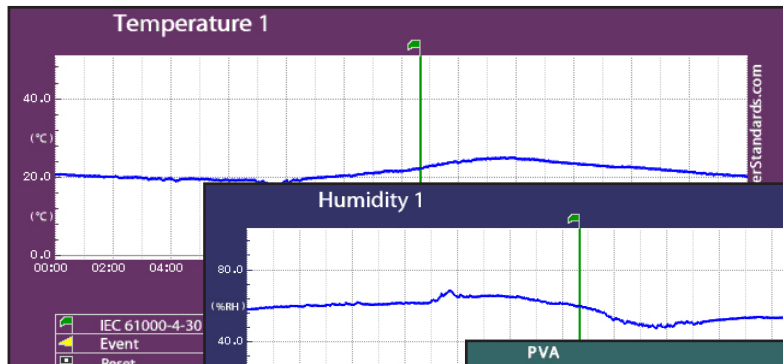

Daily 1 minute voltage trends, currents, DC channels, environment sensor channels...

**NO SOFTWARE REQUIRED**

Humidity

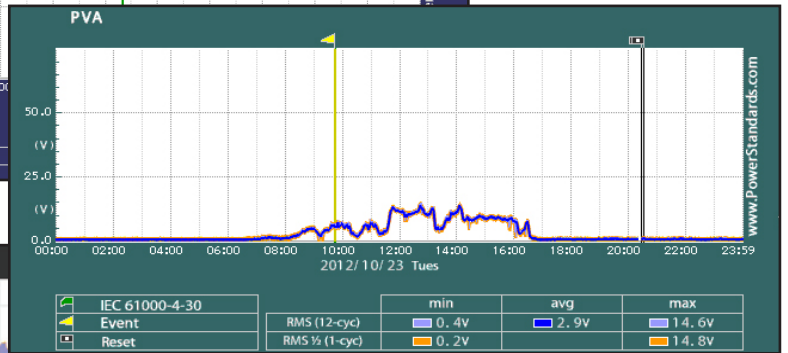

DC Channels

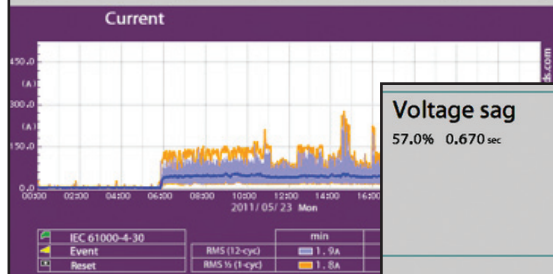
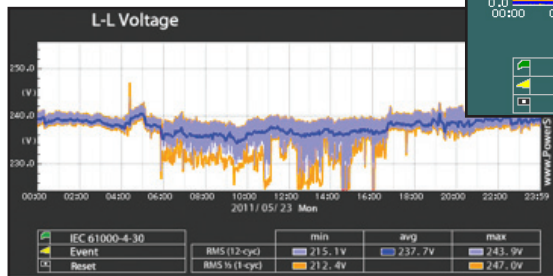

Waveform capture of voltages and currents triggered by events such as dips, swells or transients.

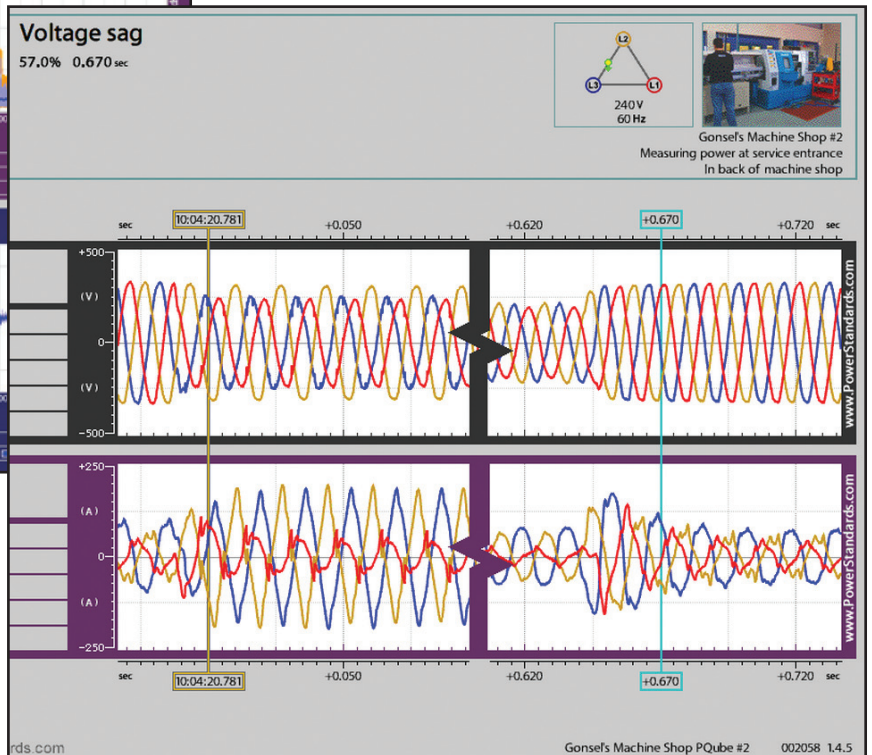

## PQube 3 - Example Wiring

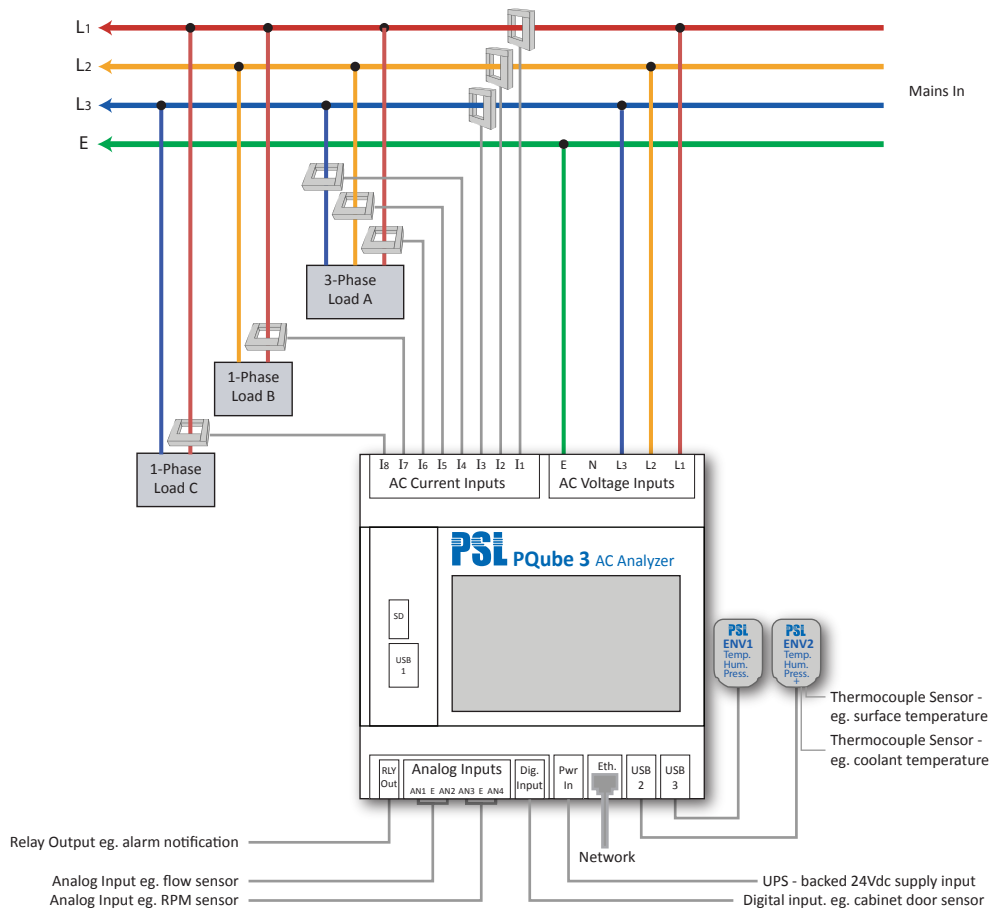

## PQube 3 - Dimensions

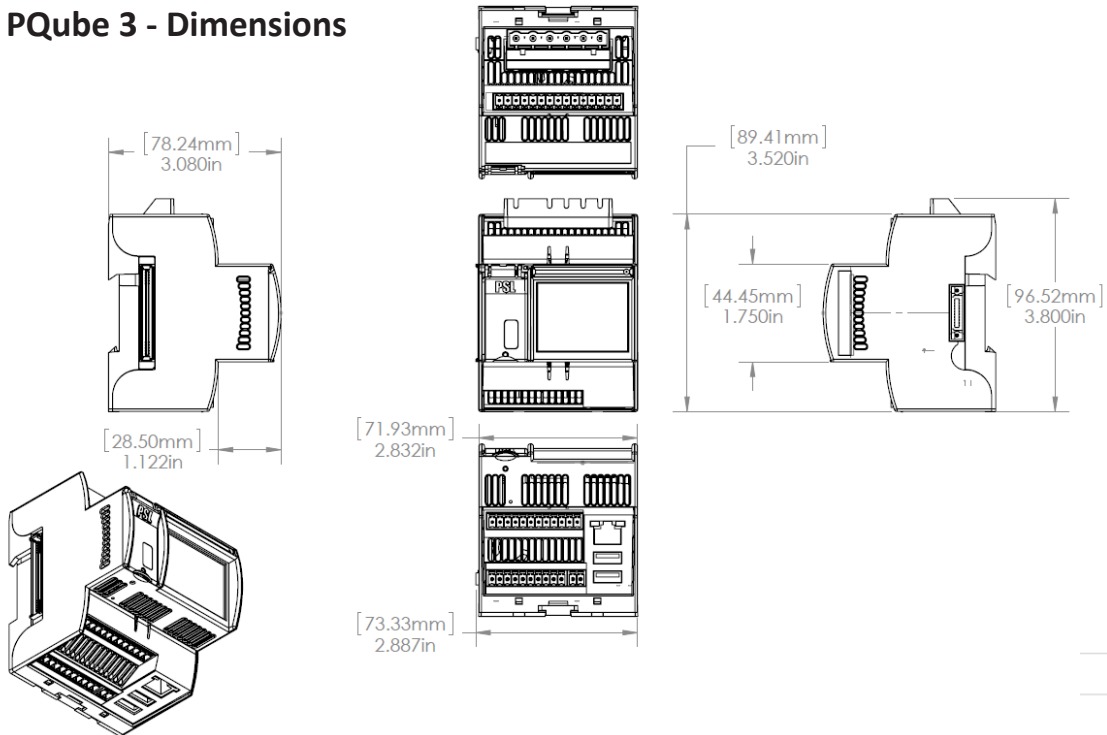



Our company: [www.PowerSensorsLtd.com](http://www.PowerSensorsLtd.com)  
The PQube 3 page: [www.PQube3.com](http://www.PQube3.com)  
Our authorized distributors: [www.PQube3.com/distributors](http://www.PQube3.com/distributors)  
Our customers: [www.PQube3.com/customers](http://www.PQube3.com/customers)

Test-drive a PQube at [map.PQube.com](http://map.PQube.com)

