



Model: AZSFP-2SLC

DESCRIPTION

AZSFP-2SLC is a SFP transceivers with high performance, cost effective modules supporting dual data-rate of 1.25Gbps/1.0625Gbps and 20km transmission distance with SMF. The transceiver consists of three sections: a FP laser transmitter, a PIN photodiode integrated with a trans-impedance preamplifier (TIA) and MCU control unit. All modules satisfy class I laser safety requirements. The transceivers are compatible with SFP Multi-Source Agreement (MSA) and SFF-8472. For further information, please refer to SFP MSA.

FEATURES

- Supports 1.25Gbps/1.0625Gbps bit rates
- Duplex LC connector
- Hot pluggable SFP footprint
- 1310nm FP laser transmitter and PIN photo-detector
- Applicable for 20Km SMF connection
- Low power consumption, < 0.8W
- Digital Diagnostic Monitor Interface
- Compliant with SFP MSA and SFF-8472
- Very low EMI and excellent ESD protection
- Operating case temperature:
- Commercial: 0 to 70 °C

Functional Diagram:

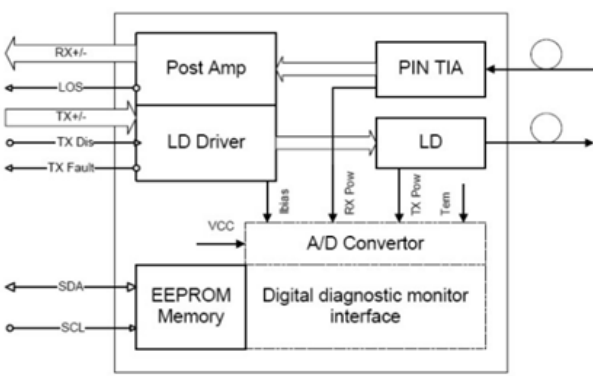

Absolute Maximum Ratings

Parameter	Symbol	Min.	Max.	Unit	Note
Supply Voltage	Vcc	-0.5	4.0	V	
Storage Temperature	TS	-40	85	°C	
Relative Humidity	RH	0	85	%	

Note: Stress in excess of the maximum absolute ratings can cause permanent damage to the transceiver.

General Operating Characteristics

Parameter	Symbol	Min.	Typ	Max.	Unit
Data Rate	DR	1.0625	1.25		Gb/s
Supply Voltage	Vcc	3.13	3.3	3.47	V
Supply Current	Icc ₅			220	mA
Operating Case Temp.	Tc	0		70	°C
	Tl	-40		85	

Electrical Characteristics (TOP(C) = 0 to 70 °C, VCC = 3.13 to 3.47 V)

Parameter	Symbol	Min.	Typ	Max.	Unit	Note
Transmitter						
Differential data input swing	VIN,PP	120		820	mVpp	1
Tx Disable Input-High	VIH	2.0		Vcc+0.3	V	
Tx Disable Input-Low	VIL	0		0.8	V	
Tx Fault Output-High	VOH	2.0		Vcc+0.3	V	2
Tx Fault Output-Low	VOL	0		0.5	V	2
Input differential impedance	Rin		100		Ω	
Receiver						
Differential data output swing	Vout,pp	300	650	800	mVpp	3
Rx LOS Output-High	VROH	2.0		Vcc+0.3	V	2
Rx LOS Output-Low	VROL	0		0.8	V	2

Notes:

1. TD+/- are internally AC coupled with 100Ω differential termination inside the module.
2. Tx Fault and Rx LOS are open collector outputs, which should be pulled up with 4.7k to 10kΩ resistors on the host board. Pull up voltage between 2.0V and Vcc+0.3V.
3. RD+/- outputs are internally AC coupled, and should be terminated with 100Ω (differential) at the user SERDES.

Optical Characteristics (TOP(C) = 0 to 70 °C, VCC = 3.13 to 3.47 V)

Parameter	Symbol	Min.	Typ	Max.	Unit	Note
Transmitter						
Operating Wavelength	λ	1270	1310	1360	nm	
Ave. output power (Enabled)	PAVE	-9		-3	dBm	1
Extinction Ratio	ER	9			dB	1
RMS spectral width	Δλ			0.65	nm	
Rise/Fall time (20%~80%)	Tr/Tf			0.26	ns	2
Dispersion penalty	TDP			3.9	dB	
Output Optical Eye		Compliant with IEEE802.3z (class 1 user safety)				
Receiver						
Operating Wavelength	λ	1260		1610	nm	
Receiver Sensitivity	PSEN1			-22	dBm	3
Overload	PAVE	-3			dBm	3
LOS Assert	Pa	-35			dBm	
LOS De-assert	Pd			-24	dBm	
LOS Hysteresis	Pd-Pa	0.5			dB	

Notes:

1. Measured at 1250Mb/s with PRBS 2²³⁻¹ NRZ test pattern.
2. Unfiltered, measured with a PRBS2²³⁻¹ test pattern @1.25Gbps
3. Measured at 1250Mb/s with PRBS 2²³⁻¹ NRZ test pattern for BER < 1x10⁻¹²

Pin Definition And Functions

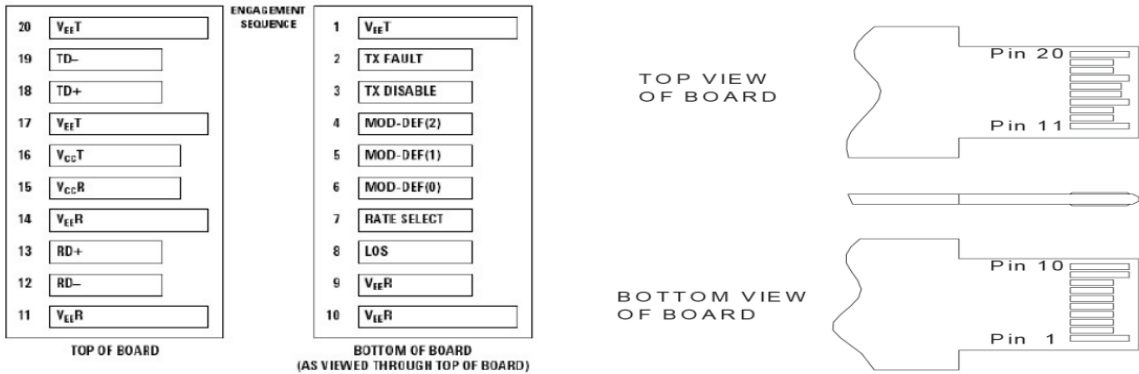

Pin	Symbol	Name/Description	Notes
1	VeeT	Tx ground	
2	Tx Fault	Tx fault indication, Open Collector Output, active "H"	1
3	Tx Disable	LVTTTL Input, internal pull-up, Tx disabled on "H"	2
4	MOD-DEF2	2 wire serial interface data input/output (SDA)	3
5	MOD-DEF1	2 wire serial interface clock input (SCL)	3
6	MOD-DEF0	Model present indication	3
7	Rate select	No connection	
8	LOS	Rx loss of signal, Open Collector Output, active "H"	4
9	VeeR	Rx ground	
10	VeeR	Rx ground	
11	VeeR	Rx ground	
12	RD-	Inverse received data out	5
13	RD+	Received data out	5
14	VeeR	Rx ground	
15	VccR	Rx power supply	
16	VccT	Tx power supply	
17	VeeT	Tx ground	
18	TD+	Transmit data in	6
19	TD-	Inverse transmit data in	6
20	VeeT	Tx ground	

Notes:

1. When high, this output indicates a laser fault of some kind. Low indicates normal operation. And should be pulled up with a 4.7 – 10KΩ resistor on the host board.

2. TX disable is an input that is used to shut down the transmitter optical output. It is pulled up within the module with a 4.7 – 10KΩ resistor. Its states are:

Low (0 – 0.8V): Transmitter on (>0.8, < 2.0V): Undefined
High (2.0V~Vcc+0.3V): Transmitter Disabled Open: Transmitter Disabled

3. Mod-Def 0,1,2. These are the module definition pins. They should be pulled up with a 4.7K – 10KΩ resistor on the host board. The pull-up voltage shall be between 2.0V~Vcc+0.3V.

Mod-Def 0 has been grounded by the module to indicate that the module is present

Mod-Def 1 is the clock line of two wire serial interface for serial ID

Mod-Def 2 is the data line of two wire serial interface for serial ID

4. When high, this output indicates loss of signal (LOS). Low indicates normal operation.

5. RD+/-: These are the differential receiver outputs. They are AC coupled 100Ω differential lines which should be terminated with 100Ω (differential) at the user SERDES. The AC coupling is done inside the module and is thus not required on the host board.

6. TD+/-: These are the differential transmitter inputs. They are AC-coupled, differential lines with 100Ω differential termination inside the module. The AC coupling is done inside the module and is thus not required on the host board.

Digital Diagnostic Specifications

The AZSFP-2SLC transceivers can be used in host systems that require either internally or externally calibrated digital diagnostics.

Parameter	Symbol	Units	Min.	Max.	Accuracy	Note
Transceiver temperature	DTemp-E	°C	-5	+75	±5°C	
Transceiver supply voltage	DVoltage	V	2.8	4.0	±3%	
Transmitter bias current	DBias	mA	2	15	±10%	1
Transmitter output power	DTx-Power	dBm	-12	-1	±3dB	
Receiver average input power	DRx-Power	dBm	-25	0	±3dB	

Notes:

1. The accuracy of the Tx bias current is 10% of the actual current from the laser driver to the laser
2. Internal/ External Calibration compatible.

Typical Interface Circuit

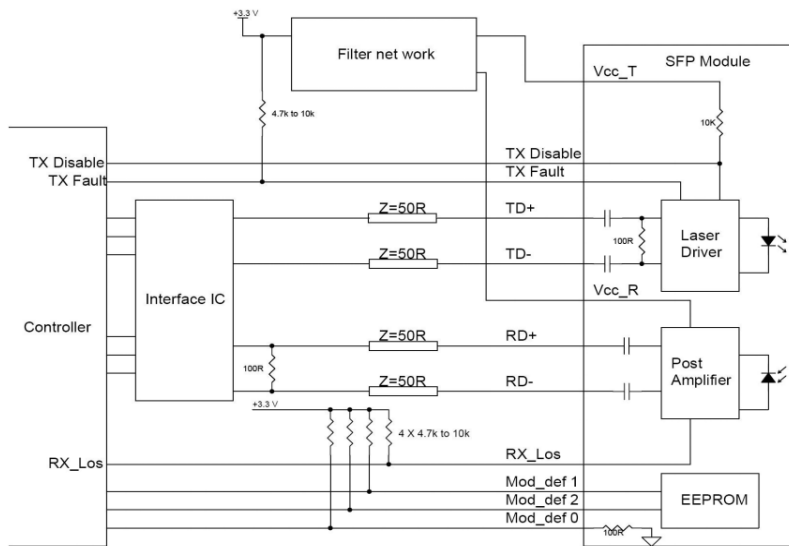

Package Dimensions

