

WITH MECHANICAL SEAL
AND SEALLESS



DRUM PUMPS STAINLESS STEEL

IF NO CONTAMINATION AND PRODUCT
CARRYOVER IS ALLOWED



FOOD



BEVERAGE



PHARMACEUTICAL



COSMETICS

Drum pumps stainless steel with mechanical seal (MS) and sealless (SL)

DRUM PUMPS STAINLESS STEEL

IF EASY CLEANING, DURABILITY AND EXPLOSION-PROOF ARE REQUIRED



PAINTS + COATINGS



ACIDS + BASES



SOLVENTS



SPECIAL APPLICATIONS, PLANT ENGINEERING



Our new pumps!

The quickest way to get to know us is to contact us directly. Save your precious time.

Contact us and we will do the rest for you.

Consulting service, product selection, project planning assistance and quote – fast and all free of charge.

Advantages

more ...

- practical
- variable
- complete
- hygienic
- solid
- robust
- imaginative
- fit for use
- modular
- individual

Sealed and sealless pumps types have grown closer to one another

The SD (Simple Disassembly) series is sealed with a mechanical seal (MS). In the SL series (sealless) there is an inner tube in the pump tube. The leakage unit depressurises the inner tube. The drive shaft is running within the inner tube. With no pressure difference between the inner tube and the outside ambient air no liquid can leave the pump, where the drive shaft comes out from the pump head. The pump is therefore always without leakage at the pump head.

Tel. +49 93 42 / 9 35 16-0
info@gruen-pumpen.de



In this booklet you will learn a lot about grün-drum pumps. We are sure you will experience proof of our commitments and product statements when using our equipment.

Online you can learn interesting facts about 'grün-business-philosophy' in a three minute audio slideshow.

Worth seeing.





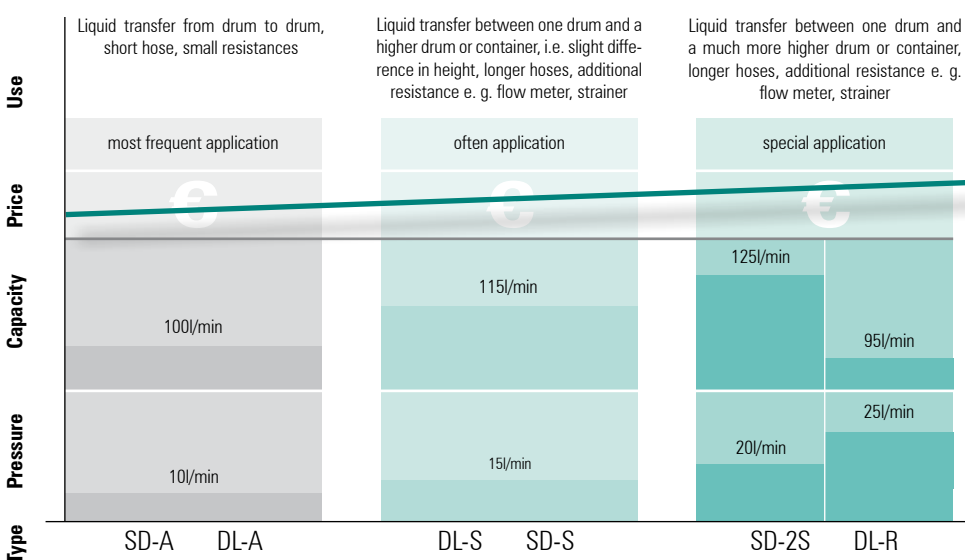

www.gruen-pumpen.de

The right pump for your application



drum pumps stainless steel with features for the top position

DRUM PUMPS STAINLESS STEEL

	SD-SS-	A	S	DL-SS-
important for your application				
large capacity		X		
high pressure			X	
viscosity up to 1.500 mPas (pd500)			X	
hydraulic tuning			X	
many different liquids				X
mixing function				
simple disassembly (SD)	X			
easy to clean	X			X
explosion proof				
continous work with induction motor			X	
tube length	container size	ord.-no.		
700 mm	hobcock 30l	631-0001	631-0006	
1000 mm	drum up to 220 l	631-0002	631-0007	
1200 mm	IBC up to 1000 l	631-0003	631-0008	
> 1200 mm	special container	on demand	on demand	
electrical motors without explosion proof				
p310 optimised in price	preferred combination	X		
p400 the ideal drive	improved hydr. performance	X	X	
pd500 silent worker	smooth product treatment		X	
electrical motors with explosion proof				
EX700 for hazardous locations	safety by power	X	X	
pd500 Ex	smooth product treatment		X	
compressed air motor for all applications				
d600 for hazardous locations	the power drive	X	X	

Drive motors, select the best drive for every

p310 optimised in price

p400 the ideal drive



properties

short and occasional use,
it likes light and thin liquids,
internal cooling

big resources in power
and durability,
works quickly and saves time,
internal cooling

options

low voltage release (LVR)
recommended according to
EU-directives, speed redu-
cer (SR) varies pressure and
capacity

low voltage release (LVR)
recommended according to
EU-directives, speed reducer (SR)
varies pressure and capacity,
IP54 with TEFC (MA)

data

power (W)

520

850

voltage (V)

230 | 120

230 | 120

protection

IP24

IP24 / IP54 | IP24

LVR*

optional

optional

SR**

optional

optional

weight (kg)

3,5

4

max. spec. gravity (kg/l)

A | 1,4

Förderelement s.S. 4/5

A / R / S | 2 / 1,8 / 1,5

max. viscosity (mPas)

250

A / R / S | 800 / 600 / 500

with LVR*

500-0016 | 500-0028

500-0023 | 500-0025

with SR** and LVR

500-0074 | 500-0060

500-0069 | 500-0066

without LVR

500-0017 | 500-0029

500-0024 | 500-0026

without LVR with SR

500-0054 | 500-0057

500-0056 | 500-0063

magnetic clutch , LVR

500-0030 | 500-0032

500-0034 | 500-0036

magnetic clutch , LVR, SR

500-0061 | 500-0062

500-0067 | 500-0068

TEFC (MA) IP54

500-0072

characteristics

* low voltage release
** speed reducer

recommended types

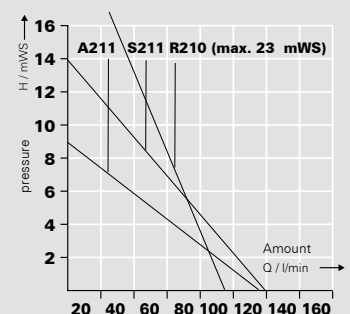
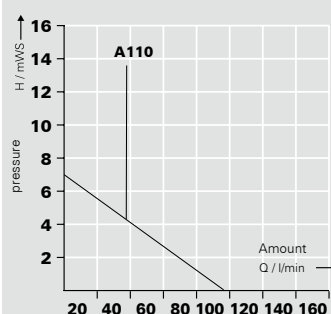

Ex700

safety through power in hazardous locations



big resources in power and durability, certified for the most liquids, external cooling (TEFC)

without LVR available for special applications

pd500

the silent marathon worker



robust, without wear, powerful for viscous liquids, smooth product treatment with feed screw (S) 2800 rpm

single phase induction motor 230 V, three phase 230/400 V, explosion proof 3- phase 230/400 V, overload protection switch

d600

the power drive for all locations



for heavy duty applications, economical air consumption, certified for hazardous locations, variable speed, starting knob fixable, lightweight

- | | |
|------------------|--------|
| 1. coupling | PA |
| 2. pump head | SS |
| 3. pump tube | SS |
| 4. Drive shaft | SS |
| 5. inner tube | SS |
| 6. slide bearing | Carbon |
| 7. Impeller | ETFE |

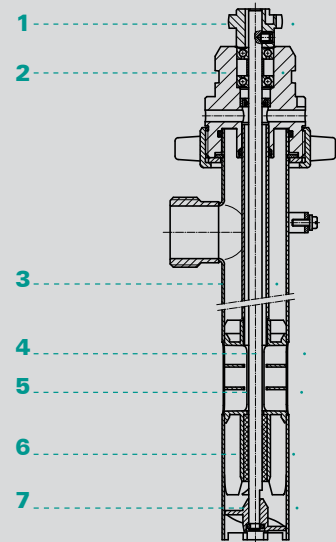

700	
230	
IP54	
EU-directive	
-	
6	
type of impeller s. p. 4/5	
A / R / S	1,8 / 1,6 / 1,4
	600 / 500 / 400

370 und 550	
230	400
IP54	
optional	
with frequency inverter (FI)	
5	5
type of impeller s. p. 4/5	
S: 2	S: 2,5
S: 1500	S: 1800

600	
compressed air	3-7 (bar)
air consumption	10 (l/s)
standard	
weight (kg)	2
type of impeller s. p. 4/5	
A / R / S	2 / 2 / 2
A / R / S	800 / 800 / 800

ord.-no
510-0010

510-0012

ord.-no	
pd500-1-0,37-230	500-0042
pd500-3-0,37 230/400	500-0039
pd500-FU-0,55 kW	500-0043
pd500 Ex-0,37 230/400	510-0009
AtEx	

ord.-no
520-0016

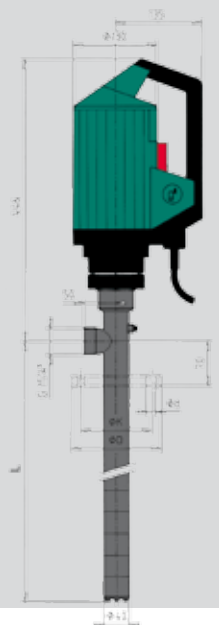
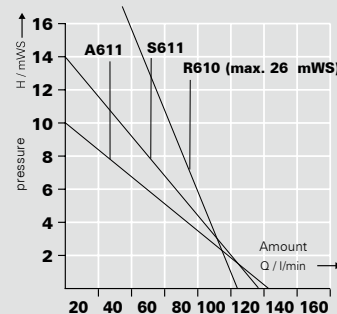
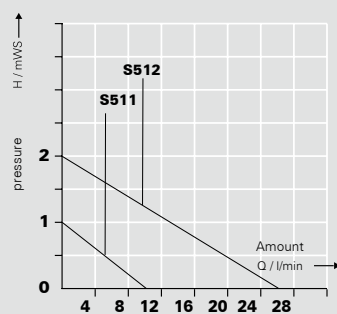
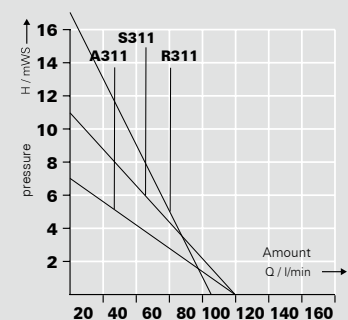

Other pumps in separate catalogue.



ACCESSORIES

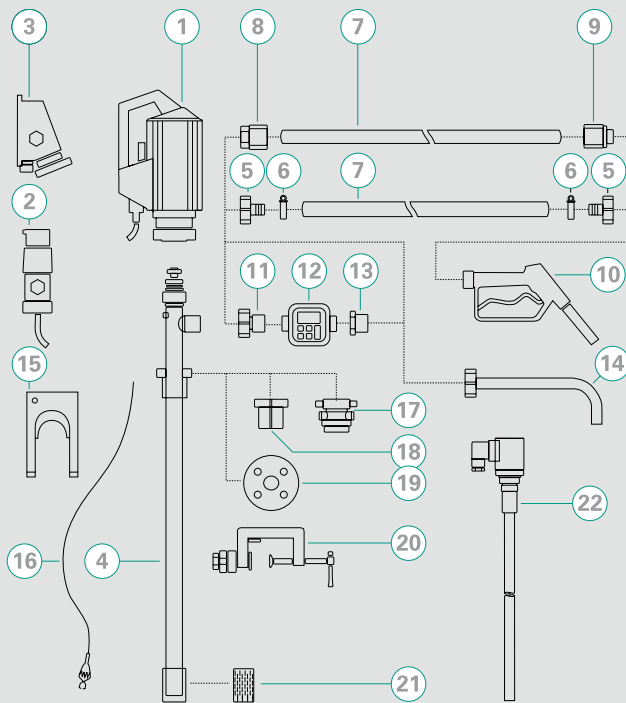

- 1 Drive motor
- 2 Explosion-proof plug
- 3 Explosion-proof socket
- 4 Pump tube
- 5 Hose connector
- 6 Hose clamps
- 7 Hose
- 8 Hose fittings
- 9 Hose fittings
- 10 Nozzle
- 11 Flow meter connection
- 12 Flow meter
- 13 Reducing piece
- 14 Discharge spout
- 15 Wall bracket
- 16 Equipotential bonding cable
- 17 Emission proof drum adapter
- 18 Drum adapter
- 19 Installation flange
- 20 Clamping device
- 21 Foot strainer
- 22 Level switch

Distributor:

grün-pumpen gmbh
Otto-Schott Str. 19
D-97877 Wertheim
Telefon +49 93 42 9 35 16-0
Telefax +49 93 42 9 35 16-29
info@gruen-pumpen.de
www.gruen-pumpen.de

Handelsregister:
Reg. Gericht Mannheim
HRB 570326
Sitz der Gesellschaft:
Wertheim
Geschäftsführer:
Ralph Dostmann, Dr. Thomas Sigel
USt.IdNr. DE 160765854

g[®]
grün-pumpen
 take out, what's in.