

The blocks may be terminated with Impact Tool 569994-1. Remove loose wire pieces. If tool does not properly trim wires, replace tool blade with Replacement Blade 569995-1. Use of other cutting tools to trim wires may damage patch panel.

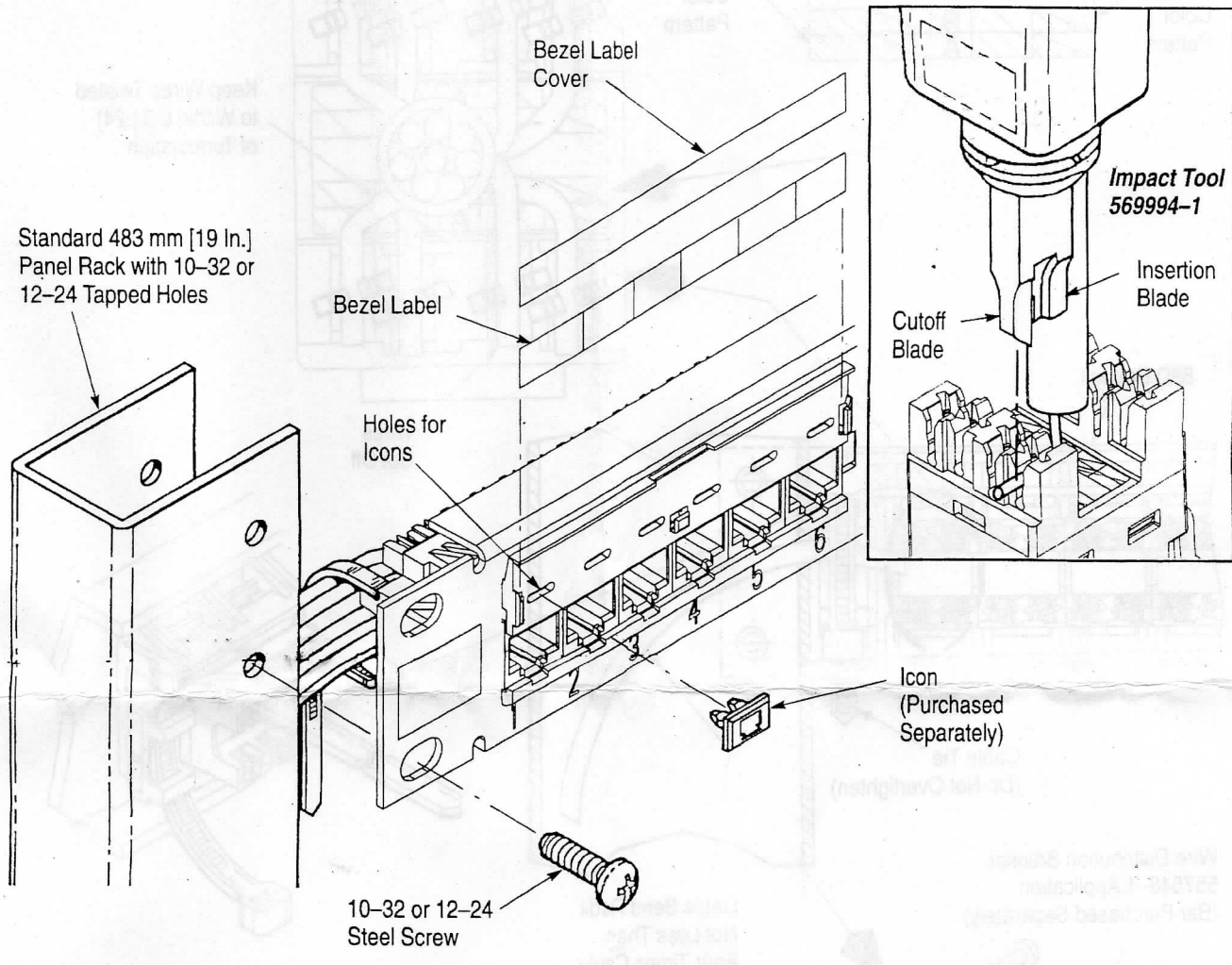

Figure 1

## 1. INTRODUCTION

This instruction sheet covers the installation procedures for CAT 6 System Modular Universal Wiring Patch Panels. The panels can be mounted on any standard 483 mm [19 in.] equipment rack or communication cabinet as shown in Figure 1.

**NOTE** All dimensions are in millimeters [with inches in brackets]. Figures are not drawn to scale.

Reasons for reissue of this sheet are provided in Section 4, REVISION SUMMARY.

## 2. DESCRIPTION

Each panel includes the necessary mounting hardware, bezel labels, bezel label covers, and cable management cable ties. See Figures 1 and 2.

## 3. INSTALLATION PROCEDURES

### 3.1. General Instructions (Figure 2)

Assemble cable ties or cable management bar(s).

### 3.2. Special Instructions for Performance Transmission Applications

**NOTE** At all times, the wiring practices must comply with practices of ANSI/TIA/EIA-568-A Specification.

Guidelines covered in this specification and shown in Figure 2 must be followed.