

SPECIFICATION

- Wafer Type Butterfly Valve PN16
- Two-Piece-Stem pinless design
- ISO 5211 DIN3337 direct mounting pad

Design Standard	: BS EN593 / API 609
Face to Face	: BS EN558-1 / API 609
Flange Connection	: EN1092-1 PN10/16 JIS B2210 10K
	: DIN 2501 PN10/16 ANSI B16 125/150
Test Standard	: BS EN 12266-1 / API 598
Pressure Rating	: 16 bar
Working Temperature	: PTFE -10 to +120 °C



#ACT / ACU - PTFE SEAT

MATERIAL LIST

NO.	PART NAME	MATERIAL	
		ACT	ACU
1	Body	Cast Iron	Cast Iron
2	Disc	Teflon coated	CF8M
3	Lower stem	SS410	SS410
4	Seat	PTFE	PTFE
5	Upper stem	SS410	SS410
6	Lock pin	AISI1066	AISI1066
7	Lower O-ring	EPDM	EPDM
8	Bushing	PTFE	PTFE
9	O-ring	EPDM	EPDM
10	Bushing	PTFE	PTFE

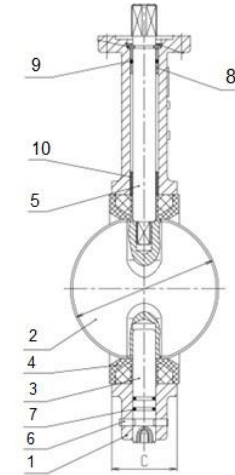

APPLICATIONS

- Suitable for Hot / Cold Water, Oil, Gas & Air

DIMENSIONS (mm)

Size	Inch	1-1/2	2	2-1/2	3	4	5	6	8	10	12	14	16	18	20	24
	DN	40	50	65	80	100	125	150	200	250	300	350	400	450	500	600
L	33	43	46	46	52	56	56	60	68	78	78	102	114	127	154	
A	138	161	175	181	200	215	226	260	292	337	368	400	422	480	562	
B	75	80	89	95	114	127	139	175	203	242	267	309	345	360	475	
C	25	25	25	25	25	35	35	35	35	25	25	25	60	60	82	
∅ D	42.6	52.6	64.3	78.8	104.0	123.3	155.7	202.6	250.4	301.5	333.3	389.6	440.5	491.6	592.5	
∅ D1	12.60	12.60	12.60	15.77	15.77	18.92	18.92	22.10	28.45	31.60	31.60	37.95	42.86	45.72	53.98	
TOP FLANGE	FxF	50	50	50	50	70	70	70	70	102	102	102	140	140	165	165
	W	35	35	35	35	55	55	55	55	70	70	70	100	100	130	130
	∅ d	7	7	7	7	10	10	10	10	12	12	12	18	18	23	23
	HxH	9x9	9x9	9x9	11x11	11x11	14x14	14x14	17x17	22x22	22x22	22x22	27x27	27x27	36x36	36x36
	∅ E	50	50	50	50	70	70	70	70	102	102	102	140	140	165	165
	ISO	F05	F05	F05	F05	F07	F07	F07	F07	F10	F10	F10	F14	F14	F16	F16
Weight (kg)	2.0	2.1	2.8	3.1	4.5	6.8	8.7	13.9	19.7	28.7	41.3	59.8	79.0	128.0	188.0	

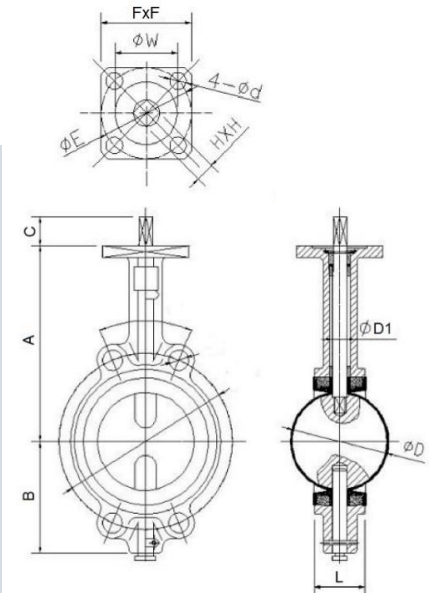

The specification and dimensions are subject to change without prior notice!

ALUMINUM HAND LEVER

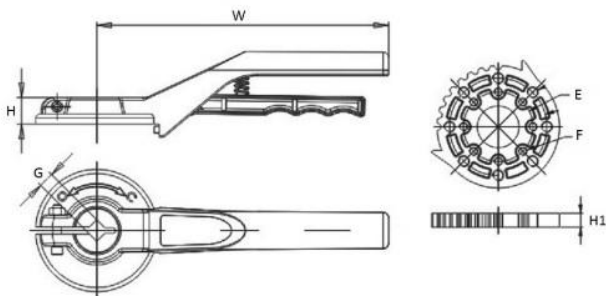

HANDWHEEL GEARBOX

- ISO 5211 Direct Mounting
- Weatherproof IP65
- Adjustable angle -5 °C to +5 °C
- Filled with special lubricant

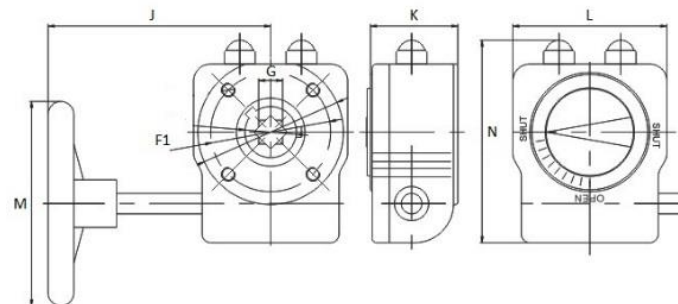

MATERIAL LIST

NO.	PART NAME	ACMG
1	Body	Aluminum alloy
2	Worm gear	Ductile iron
3	Worm	Carbon steel
4	Shaft	Stainless steel
5	Handwheel	Carbon steel

ALUMINUM HAND LEVER / GEARBOX

Valve Size	Inch	1-1/2	2	2-1/2	3	4	5	6	8	10	12	14	16	18	20	24	
	DN	40	50	65	80	100	125	150	200	250	300	350	400	450	500	600	
Hand Lever	Art No.	ACML-09			ACML-11		ACML-14			--	--	--	--	--	--	--	--
	G	9x9			11x11		14x14			--	--	--	--	--	--	--	--
	H	14			14		23			--	--	--	--	--	--	--	--
	H1	10			10		12			--	--	--	--	--	--	--	--
	W	210			210		340			--	--	--	--	--	--	--	--
Handwheel Gearbox	Art No.	ACMG-09			ACMG-11		ACMG-14		ACMG-17	ACMG-22			ACMG-27/A		ACMG-36		
Output Torque	Nm	180			180		300		540	675			1300	1500	3250		
	G	9x9			11x11		14x14		17x17	22x22			27x27		36x36		
	J	160			160		160		215	225			325	375	395		
	K	48			48		48		56	69			83	95	105		
	L	80			80		80		120	142			178	185	230		
	M	140			140		200		250	300			400	400	600		
	N	115			115		115		150	180			215	225	268		
	F1	F05/F07			F05/F07		F07		F07/F10	F10/F12			F14	F14	F16		
Weight for Gearbox (Lever)	kg	1.2 (0.4)			1.2 (0.4)		2.1 (0.95)		3.5 (0.95)	4.8			8.5	9.5	17.5		

The specification and dimensions are subject to change without prior notice!