

VALUE VALVES

VF-9 Series Double Eccentric

Value Valves is the only company in Taiwan and one of the small number companies in Asia could announce that it has successfully completed the Safety Integrity Level 3 according to IEC 61508-1 and ISO 9001 of VF-9 Series high performance butterfly valves in full series by TUV.

FEATURES AND BENEFITS

- It Awarded the PED Module H Pressure equipment container verification.
- Body hardness accord to API 598 and ASME B16.34.
- VF-94/VF-95/VF-96 Series - ANSI CLASS 300 LB: Special dust-proof design of shaft to prevent the corrosion fluids into the shaft and cause stuck. It's suitable for most of the applications of Petrochemical, Oil Refining, Air Separation · CDA with different temperature and pressure.
- Emission test to TA-LUFT, ISO 15848-1, ANSI/ISA-SP-93.
- The full series passed the GOST.
- Manufacture License of Special Equipment People's Republic test to TSG D7002.
- VF-93 and VF-96 Series metal seat design for leakage rated at ANSI FCI 70-2-2003 Table 1 CLASS V
- The full series obtained the SIL3 certificate according to IEC 61508-1.
- The mounting top meets ISO 5211 which could be easy to install actuators and extension stem used for high and low temperature.
- One-Piece shaft design is Blow-Out Proof ATEX according to ATEX 94/9/CE Group II Category 2 GD and is equipped with Anti-Static devices.
- Size:
ANSI CLASS 150LB : 2"~48"(50mm~1200mm);
ANSI CLASS 300LB : 2.5"~24"(65mm~600mm) ·
- Pressure Rating :
ANSI CLASS 150LB : PN25
ANSI CLASS 350LB : PN50



- Patented Seat Retainer Ring attaches without bolts allowing complete uninterrupted seal face with all VF-9 series.
- VF-9 series is designed to be 90 degrees rotary and torque seated, the seat is chosen by Teflon Seat and Metal Seat.
- The design of heating jacket and flashing nozzles are available on customers' requirement which apply to the temperature changes prevent fluid crystallization.
- Temperatures Range :
 VF-91/VF-94 Series-Soft Seat:-20 °F ~410 °F (-29°C ~ 210°C)
 VF-92/VF-95 Series- Fire Seat:-20 °F ~410 °F (-29°C ~ 210°C)
 VF-93/VF-96 Series-Metal Seat:-20 °F ~932 °F (-29 °C ~ 500°C)
- Three types with different applications:
 - VF-91 & 94 series, soft seat design with temperature using limits. Usually apply to the temperature under 427 °F (220°C).
 - VF-92 & 95 series, Fire safe design with API 607.
 - VF-93 and VF-96 series, is suitable for the normal atmospheric temperature location of Petrochemical industry, the high temperature over 932 °F (500°C)location of Petrochemical and Oil Refining. Value Valves VF-9 series can be provided on customer's requirements.
- Standard material is A216WCB 、 A351CF8 、 A351CF8M, more detail please consult with VALUE VALVESCO .,LTD.



APPLICATIONS

- Oil Refining
- Air Separation
- Fossil & Cogeneration Power
- Petrochemical
- Steel Mill
- LNG
- Refinery
- Pulp & Paper
- CDA



PRESS ASSISTED to GIVE BI-DIRECTIONAL

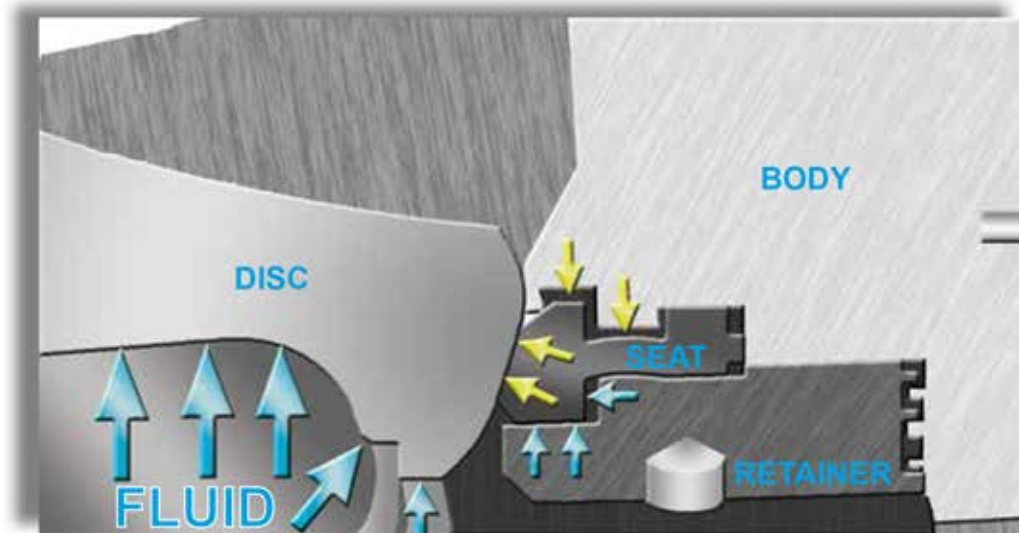

Special design of floatable retainer and seat cause the better sealing effect, bi-directional function, and increase the life cycle upper to two million times.

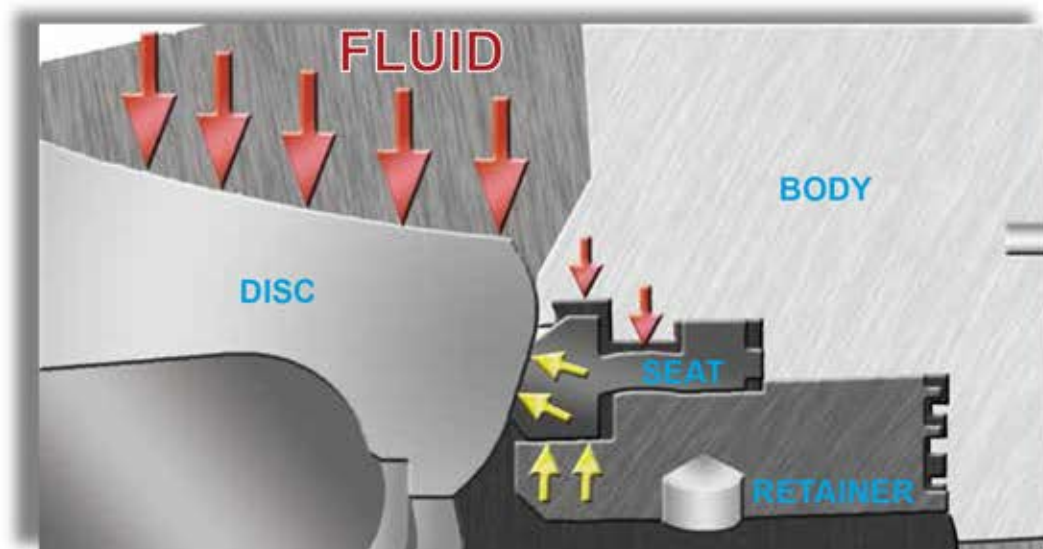

SPECIFICATION

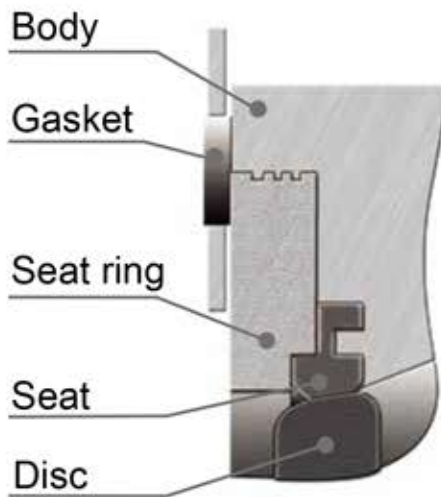

Value's Patent Design

Special twin thread design between Body and Retainer to offer:

- Wider sealing face between flanges.
- 100% sealing between retainer and body.
- When long time storage, valve was in fully closed position and the seat ring was fix by retainer, it will not cause PTFE enlarge.
- The retainer has to be at upstream when valve was installed at dead end of pipeline.
- NOTE: Retaining ring must be up stream for dead end service.

Conventional Design

- The seat retainer of some brands extended as a flange surface, which has to be sealed by a gasket and increase a risk of leakage.
- Most of the seat retainer was fixed by socket bolts, which caused reducing sealing face between flanges and increase a risk of leakage.
- When long time storage, valve was in fully closed position and the seat ring was fix by retainer, it may cause PTFE enlarge and leaking when service.

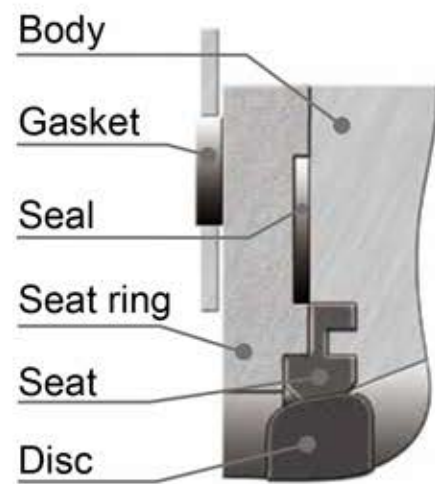
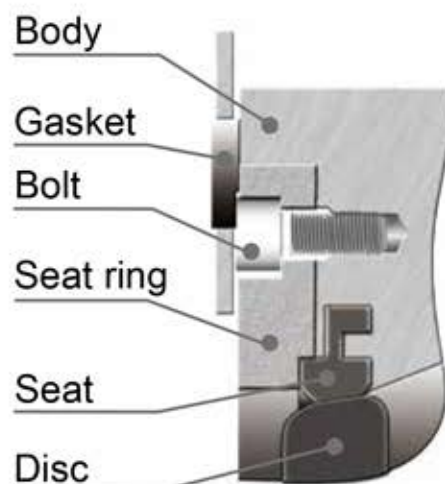

TORQUE CHART (Nm) - including 30% Safety Factor

ANSI CLASS 150LB

JIS 10K · 16K · 20K

ISO PN 10-PN 25

VF-91_Series

Size		Differential pressure (kg/cm ²)					
mm	inch	0	5	10	15	20	25
50	2"	13	15	17	20	22	25
65	2.5"	19	22	29	35	41	51
80	3"	26	29	37	44	51	59
100	4"	35	41	51	61	77	85
125	5"	51	64	76	89	105	127
150	6"	62	83	103	118	147	176
200	8"	89	114	147	166	204	242
250	10"	150	211	261	309	394	489
300	12"	196	294	374	539	625	828
350	14"	382	539	784	980	1176	1323
400	16"	573	686	980	1176	1372	1568
450	18"	783	963	1225	1470	1666	1911
500	20"	1000	1411	1764	2058	2470	2822
600	24"	1225	1680	2205	2660	3045	3325

VF-92_Series

Size		Differential pressure (kg/cm ²)					
mm	inch	0	5	10	15	20	25
50	2"	29	32	39	43	49	59
65	2.5"	37	46	61	69	83	97
80	3"	50	61	76	92	107	127
100	4"	76	88	103	118	140	162
125	5"	118	137	170	194	223	242
150	6"	147	196	225	265	294	333
200	8"	176	235	294	353	421	480
250	10"	255	323	421	480	568	647
300	12"	333	470	549	686	862	1009
350	14"	461	725	833	990	1196	1421
400	16"	657	960	1264	1509	1686	1882
450	18"	843	1058	1362	1705	2087	2646
500	20"	1078	1382	1803	2166	2920	3410
600	24"	1274	1617	2225	2783	3783	4704

VF-93_Series

Size		Differential pressure (kg/cm ²)					
mm	inch	0	5	10	15	20	25
50	2"	39	49	59	65	75	82
65	2.5"	46	56	78	102	127	147
80	3"	56	71	88	118	140	167
100	4"	78	102	122	157	178	216
125	5"	108	140	154	182	211	248
150	6"	137	169	199	232	265	319
200	8"	206	255	294	333	372	434
250	10"	265	333	402	470	578	686
300	12"	372	461	559	735	931	1176
350	14"	539	676	843	1019	1245	1421
400	16"	764	990	1225	1490	1764	2058
450	18"	902	1107	1441	1803	2205	2871
500	20"	1294	1411	1882	2352	2940	3410
600	24"	1529	1764	2176	2940	4077	6076

TORQUE CHART (Nm) - including 30% Safety Factor

Size		VF-94_Series						
mm	inch	Differential pressure (kg/cm ²)						
		0	10	15	20	30	40	50
65	2.5"	19	29	35	41	53	63	75
80	3"	26	37	44	51	76	91	108
100	4"	35	51	61	77	110	131	155
125	5"	51	76	89	105	159	189	224
150	6"	75	109	125	168	228	272	322
200	8"	102	156	199	248	321	384	455
250	10"	206	382	476	583	764	934	1106
300	12"	434	616	704	852	1067	1230	1456
350	14"	461	900	1132	1368	1658	1918	2270
400	16"	695	1227	1524	1712	2102	2461	2912
450	18"	953	1967	2053	2242	2803	3406	4031
500	20"	1212	2300	2322	2477	2956	3480	4118
600	24"	3040	5300	6074	6197	6890	7191	8510

Size		VF-95_Series						
mm	inch	Differential pressure (kg/cm ²)						
		0	10	15	20	30	40	50
65	2.5"	37	61	69	83	83	90	101
80	3"	50	76	92	107	113	129	145
100	4"	76	103	118	140	150	171	192
125	5"	118	170	194	223	234	267	301
150	6"	144	289	289	337	337	385	433
200	8"	433	458	458	610	610	762	762
250	10"	533	685	685	762	762	1066	1143
300	12"	533	839	914	1066	1066	1143	1312

Size		VF-96_Series						
mm	inch	Differential pressure (kg/cm ²)						
		0	10	15	20	30	40	50
65	2.5"	46	78	102	127	130	130	140
80	3"	56	88	118	140	150	163	155
100	4"	78	122	157	178	180	196	223
125	5"	108	154	182	211	211	234	267
150	6"	192	240	240	240	288	337	385
200	8"	381	458	533	533	610	610	761
250	10"	685	991	991	1066	1066	1219	1219
300	12"	761	991	1066	1066	1295	1446	1676

*VF-95_ and VF-96_ Series, 14" and up please contact to Value Valves.

*Other dimensions please consult with Value Valves.

CV FLOW COEFFICIENT

VF-91_ / VF-92_ / VF-93_Series

Size		150 LB									
mm	inch	Percent of Rated Travel									
		10%	20%	30%	40%	50%	60%	70%	80%	90%	100%
50	2"	4	13	26	39	72	126	153	204	233	153
65	2.5"	7	23	45	66	122	214	258	345	393	259
80	3"	10	34	68	101	185	324	391	523	596	392
100	4"	11	41	72	110	214	375	416	541	575	613
125	5"	17	53	106	157	290	506	611	816	931	958
150	6"	24	77	152	226	417	728	880	1176	1340	1379
200	8"	42	137	271	402	546	765	993	1303	1450	1750
250	10"	125	305	492	279	554	768	984	2060	2440	2667
300	12"	170	415	669	965	1300	1755	3059	3454	3849	4366
350	14"	222	506	796	1165	1614	2241	3122	4230	5360	5964
400	16"	172	537	902	1324	1904	2485	3703	5395	6887	7762
450	18"	392	946	1456	2040	2816	3918	5416	7061	8535	9354
500	20"	513	1197	1834	2558	3505	4943	7188	9097	11011	11824
600	24"	845	1861	2752	3911	5501	7664	10840	14424	18347	19862

*Other dimensions please consult with Value Valves.

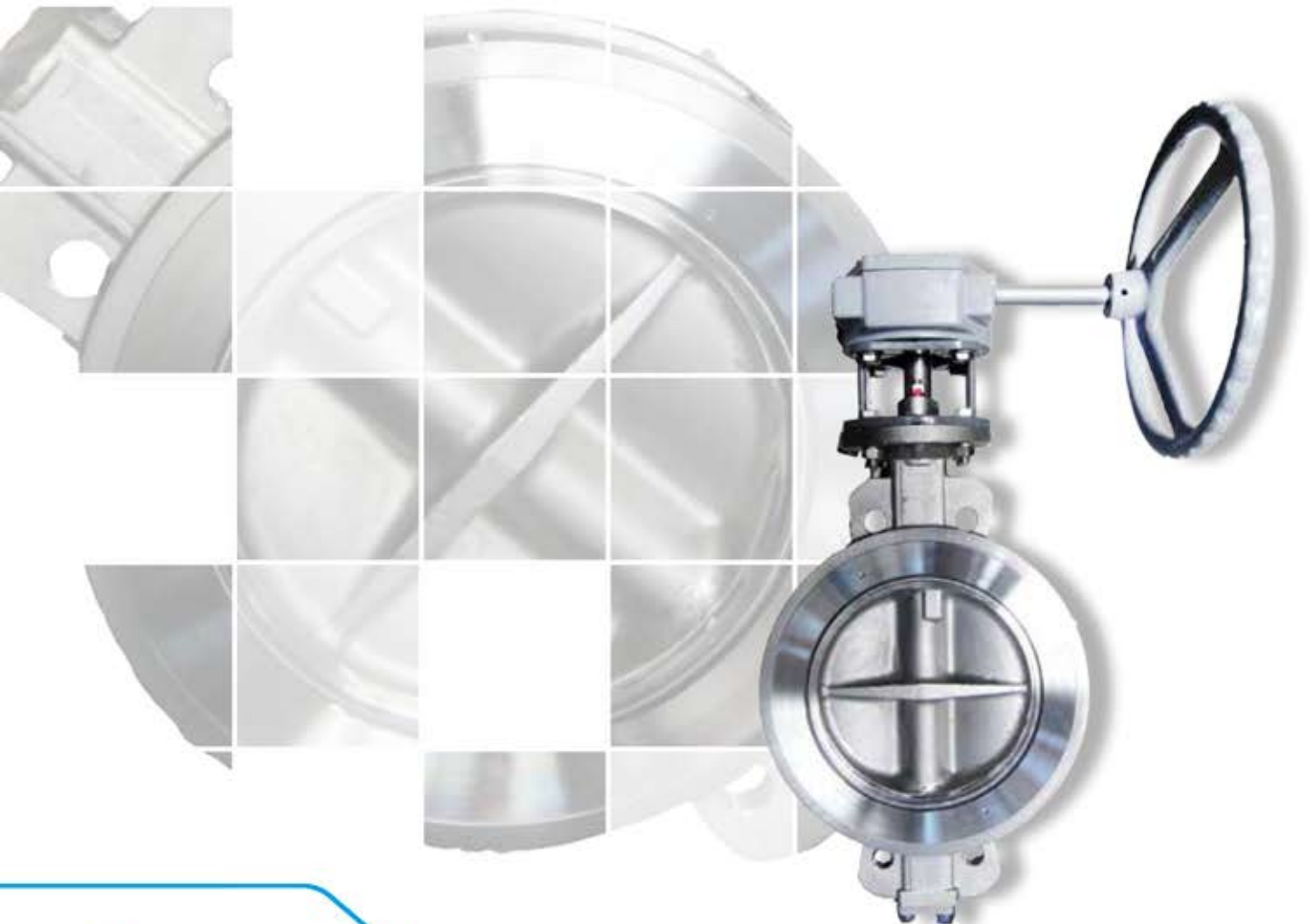

ANSI CLASS 300LB

JIS 30K · 40K

ISO PN 40-PN 50

CV FLOW COEFFICIENT



VF-94_ / VF-95_ / VF-96_ Series

Size		300LB									
		Percent of Rated Travel									
mm	inch	10%	20%	30%	40%	50%	60%	70%	80%	90%	100%
65	2.5"	7	23	45	66	122	214	258	345	393	259
80	3"	10	34	68	101	185	324	391	523	596	392
100	4"	11	41	72	110	214	375	416	541	575	613
125	5"	17	53	106	157	290	506	611	816	931	958
150	6"	21	67	149	217	350	680	800	950	1250	1270
200	8"	34	119	235	369	533	719	970	1227	1514	1631
250	10"	72	213	391	579	804	1058	1436	1870	2313	2492
300	12"	104	297	516	798	1171	1660	2299	2996	3816	3985
350	14"	122	384	678	1042	1527	2106	2893	3824	4580	4792
400	16"	245	476	968	1410	2042	2751	3779	5027	6115	6408
450	18"	310	603	1225	1784	2585	3482	4714	6227	7784	8191
500	20"	382	744	1512	2202	3191	4299	6207	8082	10227	10928
600	24"	550	1072	2178	3172	4596	6190	8938	11638	14726	15736

*Other dimensions please consult with Value Valves.

PARTS AND MATERIALS VF-91_SERIES

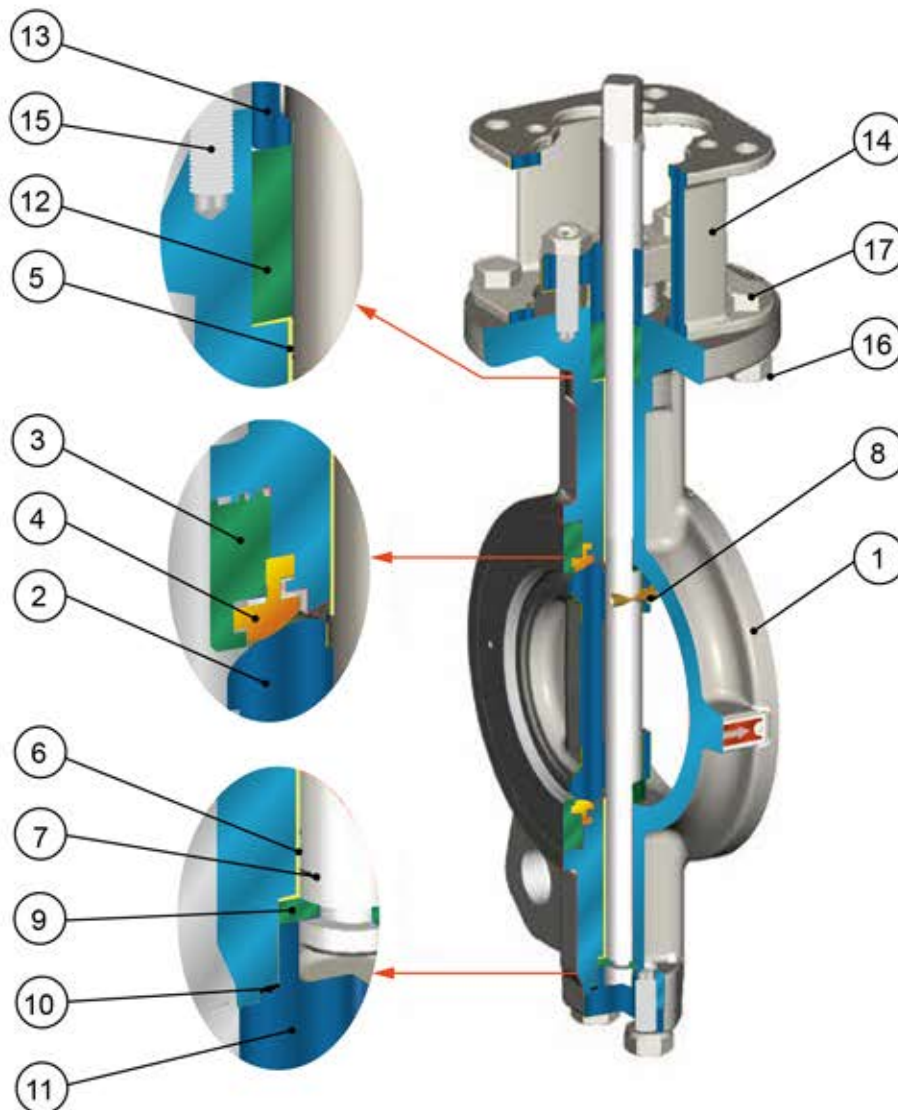

Construction Details

Integral Stop Body (1) - To prevent disc from over travel.

Retainer (3) - Patented design of square thread, ensures an un-interrupted sealing face. Flange face equipped with 125 -200AARH finish and is compatible with both flat and spiral wound gaskets.

Teflon Seat (4) - Pressure assisted to give Bi - directional bubble tight shut off at all pressures. (Valve must be installed with retaining ring upstream for dead end service.)

Bushing(5&6) - Upper and Lower bearings are constructed of PTFE impregnated 316 SS.

Stem (7) - Design with ISO 5211.

Thrust Ring (9) - Anti blow out shaft and Anti static design.

Packing (12) - Multiply Row of Teflon Chevron.

Yoke (14) - Investment Cast, per ISO 5211.

* Fugitive Emissions Packing System is available on customer required.

PARTS AND MATERIALS VF-91_SERIES

VF-91_					
No.	Name	Material	Specification		Remark
			JIS	ASTM	
1	BODY	CARBON STEEL	SC480	A216 Gr. WCB	
		STAINLESS STEEL	SCS 13A	A351 Gr. CF8	
			SCS 14A	A351 Gr. CF8M	
			SCS 16A	A351 Gr. CF3M	
2	DISC	STAINLESS STEEL	SCS 13A	A351 Gr. CF8	Disc edge has to be hard chrome plated when equipped RTFE seat
			SCS 14A	A351 Gr. CF8M	
			SCS 16A	A351 Gr. CF3M	
			SCS 13A	A351 Gr. CF8	
3	RETAINER	STAINLESS STEEL	SCS 14A	A351 Gr. CF8M	
			SCS 16A	A351 Gr. CF3M	
			SCS 13A	A351 Gr. CF8	
4	TEFLON SEAT	PTFE			-29°C ~ 160°C
		PTFE+15%GLASS FIBER	RPTFE		-29°C ~ 180°C
		PTFE+15%GRAPHITE	RPTFE		-29°C ~ 210°C
5	BUSHING	PTFE+316SS			
6	BUSHING	PTFE+316SS			
7	STEM	STAINLESS STEEL	SUS 304	A182 Gr. F304	Stem has to be hard chrome plated when equipped with PTFE + Graphite gland packing
			SUS 316	A182 Gr. F316	
			630SS	A564 Gr. 630	
			XM-19	A479 Gr. XM-19	
8	PIN	STAINLESS STEEL	SUS 316	A182 Gr. F316	
9	THRUST RING	STAINLESS STEEL	SUS 316	A240 Gr. 316	
10	SEAL	PTFE			
11	BOTTOM COVER	STAINLESS STEEL	SCS 13A	A351 Gr. CF8	
			SCS 14A	A351 Gr. CF8M	
			SCS 16A	A351 Gr. CF3M	
12	GLAND PACKING	CARBON STEEL	SC480	A216 Gr. WCB	
		PTFE			-29°C ~ 160°C
		PTFE+15%GRAPHITE	RPTFE		-29°C ~ 210°C
			SCS 13A	A351 Gr. CF8	
13	GLAND	STAINLESS STEEL	SCS 14A	A351 Gr. CF8M	
			SCS 16A	A351 Gr. CF3M	
14	YOKE	DUCTILE IRON	FCD 450	A536 Gr. 65-45-12	*(1)
		CARBON STEEL	SC480	A216 Gr. WCB	
15	STUD	STAINLESS STEEL	SUS 304	A193 Gr. B8	
16	NUT	STAINLESS STEEL	SUS 304	A194 Gr. 8	
17	BOLT	STAINLESS STEEL	SUS 304	A193 Gr. B8	

Remark:

- No. 14 materials A216 Gr. WCB is only available for F07/F05, F10/F07, F12/F10, F14/F12, F16/F14 and A536 65-45-12 for F16, F25, F30, F35, F40.
- Each materials can provide on different process of customer's requirements.

PARTS AND MATERIALS VF-92_SERIES

VF-92_					
No.	Name	Material	Specification		Remark
			JIS	ASTM	
1	BODY	CARBON STEEL	SC 480	A216 Gr. WCB	
		STAINLESS STEEL	SCS 13A	A351 Gr. CF8	
			SCS 14A	A351 Gr. CF8M	
			SCS 16A	A351 Gr. CF3M	
2	DISC	STAINLESS STEEL	SCS 13A	A351 Gr. CF8	Disc edge equipped with hard chrome plated
			SCS 14A	A351 Gr. CF8M	
			SCS 16A	A351 Gr. CF3M	
			SCS 13A	A351 Gr. CF8	
3	RETAINER	STAINLESS STEEL	SCS 14A	A351 Gr. CF8M	
			SCS 16A	A351 Gr. CF3M	
			SCS 13A	A351 Gr. CF8	
4	GASKET	GRAPHITE			
5	METAL SEAT	STAINLESS STEEL	INCONEL ALLOY	B637 FORGING STOCK	
6	SEAT	PTFE			-29°C ~ 160°C
		PTFE+15%GLASS FIBER	RPTFE		-29°C ~ 180°C
		PTFE+15%GRAPHITE	RPTFE		-29°C ~ 210°C
7	BUSHING	PTFE+316SS			
8	BUSHING	PTFE+316SS			
9	STEM	STAINLESS STEEL	SUS 304	A182 Gr. F304	Stem Equipped With Hard Chrome Plated
			SUS 316	A182 Gr. F316	
			630 SS	A564 Gr. 630	
			XM-19	A479 Gr. XM-19	
10	PIN	STAINLESS STEEL	SUS 316	A182 Gr. F316	
11	THRUST RING	STAINLESS STEEL	SUS 316	A240 Gr. 316	
12	SEAL	GRAPHITE			
13	BOTTOM COVER	STAINLESS STEEL	SCS 13A	A351 Gr. CF8	
			SCS 14A	A351 Gr. CF8M	
			SCS 16A	A351 Gr. CF3M	
			SC 480	A216 Gr. WCB	
14	GLAND PACKING	GRAPHITE			
15	GLAND	STAINLESS STEEL	SCS 14A	A351 Gr. CF8M	
			SCS 16A	A351 Gr. CF3M	
16	YOKE	DUCTILE IRON	FCD 450	A536 Gr. 65-45-12	*(1)
		CARBON STEEL	SC 480	A216 Gr. WCB	
17	STUD	STAINLESS STEEL	SUS 304	A193 Gr. B8	
18	NUT	STAINLESS STEEL	SUS 304	A194 Gr. 8	
19	BOLT	STAINLESS STEEL	SUS 304	A193 Gr. B8	

Remark:

- No. 16 materials A216 Gr. WCB is only available for F07/F05, F10/F07, F12/F10, F14/F12, F16/F14 and A536 65-45-12 for F16, F25, F30, F35, F40.
- Each materials can provide on different process of customer's requirements.

PARTS AND MATERIALS VF-93_SERIES

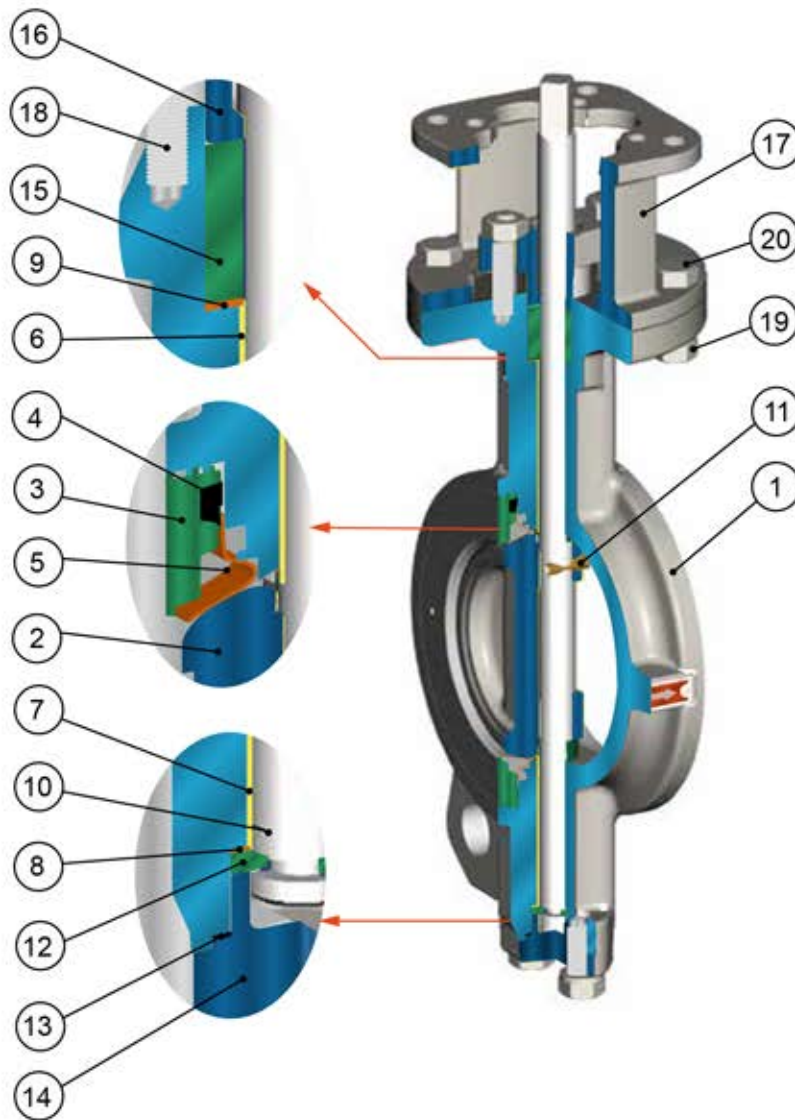

Construction Details

Integral Stop Body (1) - To prevent disc from over travel.

Retainer (3) - Patented design of square thread, ensures an un-interrupted sealing face. Flange face equipped with 125 - 200 AARH finish and is compatible with both flat and spiral wound gaskets.

Metal Seat (5) - Bi-direction self sealing metal seat design for leakage rated at Class IV per ANSI FCI 70-2 or better. (Retaining ring fixed at upstream when dead end service.)

Bushing(6&7) - Upper and Lower bearings are constructed of 316 SS Nitrided.

Stem (10) - Design with ISO 5211 .

Thrust Ring (12) -Anti blow out shaft and Anti static design.

Packing (15) - Graphite packing suit for high temperature service.

Yoke (17) - Investment Cast, per ISO 5211.

* Fugitive Emissions Packing System is available on customer required.

PARTS AND MATERIALS VF-93_SERIES

VF-93_					
No.	Name	Material	Specification		Remark
			JIS	ASTM	
1	BODY	CARBON STEEL	SC 480	A216 Gr. WCB	
		STAINLESS STEEL	SCS 13A	A351 Gr. CF8	
			SCS 14A	A351 Gr. CF8M	
			SCS 16A	A351 Gr. CF3M	
2	DISC	STAINLESS STEEL	SCS 13A	A351 Gr. CF8	Disc edge equipped with hard chrome plated
			SCS 14A	A351 Gr. CF8M	
			SCS 16A	A351 Gr. CF3M	
			SCS 13A	A351 Gr. CF8	
3	RETAINER	STAINLESS STEEL	SCS 14A	A351 Gr. CF8M	
			SCS 16A	A351 Gr. CF3M	
			SCS 13A	A351 Gr. CF8	
4	GASKET	GRAPHITE			
5	METAL SEAT	STAINLESS STEEL	INCONEL ALLOY	B637 FORGING STOCK	
6	BUSHING	STAINLESS STEEL	SUS 316	A182 Gr. F316	
7	BUSHING	STAINLESS STEEL	SUS 316	A182 Gr. F316	
8	WASHER	STAINLESS STEEL	SUS 316	A240 Gr. 316	
9	WASHER	STAINLESS STEEL	SUS 316	A240 Gr. 316	
			SUS 304	A182 Gr. F304	
			SUS 316	A182 Gr. F316	
			630 SS	A564 Gr. 630	
10	STEM	STAINLESS STEEL	XM-19	A479 Gr. XM-19	Stem Equipped With Hard Chrome Plated
			SUS 316	A182 Gr. F316	
			SUS 316	A182 Gr. F316	
11	PIN	STAINLESS STEEL	SUS 316	A182 Gr. F316	
12	THRUST RING	STAINLESS STEEL	SUS 316	A240 Gr. 316	
13	SEAL	GRAPHITE			
14	BOTTOM COVER	STAINLESS STEEL	SCS 13A	A351 Gr. CF8	
			SCS 14A	A351 Gr. CF8M	
			SCS 16A	A351 Gr. CF3M	
15	GLAND PACKING	CARBON STEEL	SC 480	A216 Gr. WCB	
		GRAPHITE			
16	GLAND	STAINLESS STEEL	SCS 13A	A351 Gr. CF8	
			SCS 14A	A351 Gr. CF8M	
17	YOKE	DUCTILE IRON	FCD 450	A536 Gr. 65-45-12	*(1)
		CARBON STEEL	SC 480	A216 Gr. WCB	
18	STUD	STAINLESS STEEL	SUS 304	A193 Gr. B8	
19	NUT	STAINLESS STEEL	SUS 304	A194 Gr. 8	
20	BOLT	STAINLESS STEEL	SUS 304	A193 Gr. B8	

Remark:

- No. 17 materials A216 Gr. WCB is only available for F07/F05, F10/F07, F12/F10, F14/F12, F16/F14 and A536 65-45-12 for F16, F25, F30, F35, F40.
- Each materials can provide on different process of customer's requirements.

PARTS AND MATERIALS VF-94_SERIES

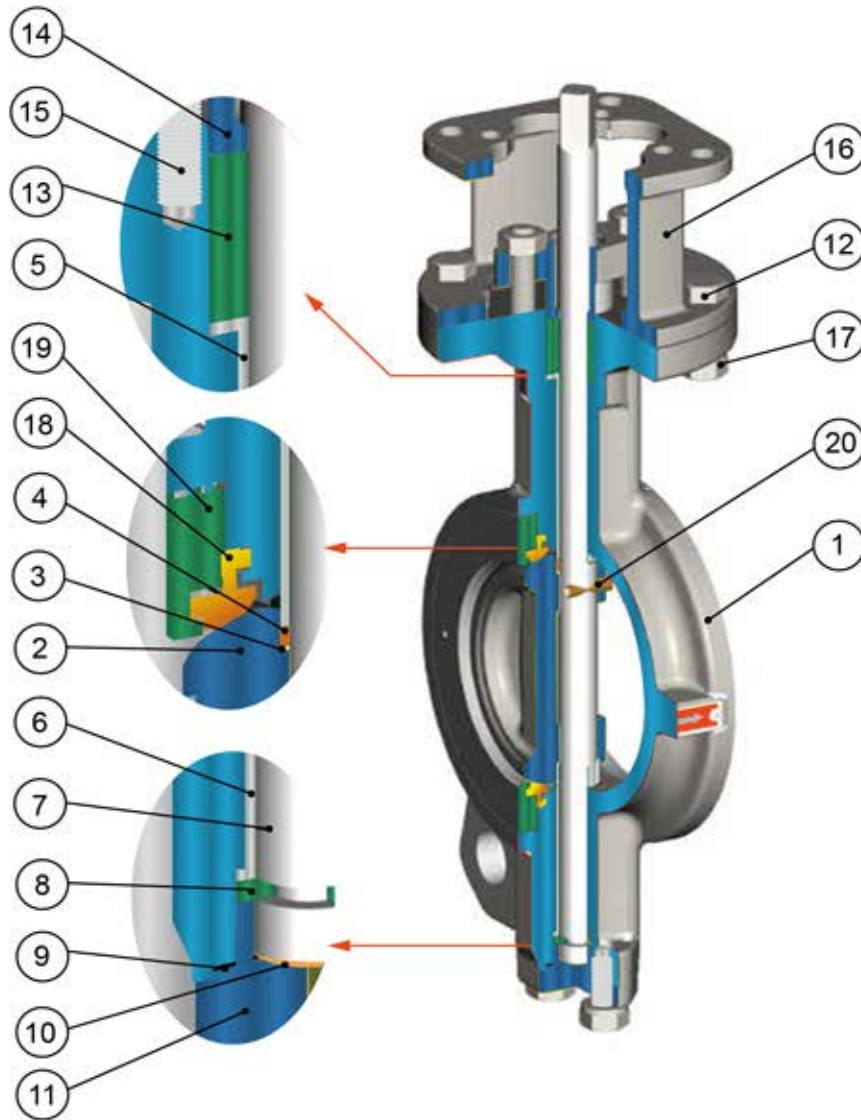

Construction Details

Integral stop Body (1) - To prevent disc from over travel.

Bushing(4-6) - Upper and Lower bearings are constructed of 316 SS.

Stem (7) - Design with ISO 5211 .

Thrust Ring (8) - Anti blow out shaft and Anti static design.

Packing (13) - Multiply Row of Teflon Chevron.

Gland FLANGE / Packing Gland (14) - One Piece assembly applies even pressure to packing.

Yoke (16) - Investment Cast, per ISO 5211.

Teflon Seat (18) - Pressure assisted to give Bi - directional bubble tight shutoff at all pressures.(Valve must be installed with retaining ring upstream for dead end service.)

Retainer (19) - Patented design of twin threads, ensures an un-inerrupted sealing face. Standard is a 125 - 200 AARH finish and is compatible with both flat and spiral wound gaskets.

* Fugitive Emissions Packing System is available on customer required.

PARTS AND MATERIALS VF-94_SERIES

VF-94_					
No.	Name	Material	Specification		Remark
			JIS	ASTM	
1	BODY	CARBON STEEL	SC 480	A216 Gr. WCB	
			SCS 13A	A351 Gr. CF8	
		STAINLESS STEEL	SCS 14A	A351 Gr. CF8M	
			SCS 16A	A351 Gr. CF3M	
2	DISC	STAINLESS STEEL	SCS 13A	A351 Gr. CF8	
			SCS 14A	A351 Gr. CF8M	
			SCS 16A	A351 Gr. CF3M	
3	SEAL-1	PTFE			
4	BUSHING	STAINLESS STEEL	SUS 316	A182 Gr. F316	
5	BUSHING	STAINLESS STEEL	SUS 316	A182 Gr. F316	
6	BUSHING	STAINLESS STEEL	SUS 316	A182 Gr. F316	Stem Equipped With Hard Chrome Plated
			SUS 304	A182 Gr. F304	
			SUS 316	A182 Gr. F316	
			630 SS	A564 Gr. 630	
7	STEM	STAINLESS STEEL	XM-19	A479 Gr. XM-19	
8	THRUST RING	STAINLESS STEEL	SUS 316	A240 Gr. 316	
9	SEAL-2	PTFE			
10	PACKING	PTFE+316SS			
11	BOTTOM COVER	STAINLESS STEEL	SCS 13A	A351 Gr. CF8	
			SCS 14A	A351 Gr. CF8M	
			SCS 16A	A351 Gr. CF3M	
12	BOLT	CARBON STEEL	SC 480	A216 Gr. WCB	
		STAINLESS STEEL	SUS 304	A193 Gr. B8	
13	GLAND PACKING	PTFE			-29°C ~ 160°C
		PTFE+15%GRAPHITE			-29°C ~ 210°C
14	GLAND	STAINLESS STEEL	SCS 13A	A351 Gr. CF8	
			SCS 14A	A351 Gr. CF8M	
15	STUD	STAINLESS STEEL	SUS 304	A193 Gr. B8	
16	YOKE	DUCTILE IRON	FCD 450	A536 Gr. 65-45-12	*(1)
		CARBON STEEL	SC 480	A216 Gr. WCB	
17	NUT	STAINLESS STEEL	SUS 304	A194 Gr. 8	
18	TEFLON SEAT	PTFE+15%GLASS FIBER			-29°C ~ 180°C
		PTFE+15%GRAPHITE			-29°C ~ 210°C
19	RETAINER	STAINLESS STEEL	SCS 13A	A351 Gr. CF8	
			SCS 14A	A351 Gr. CF8M	
			SCS 16A	A351 Gr. CF3M	
20	PIN	STAINLESS STEEL	SUS 316	A182 Gr. F316	

Remark:

- No.16 materials A216 Gr. WCB is only available for F07/F05, F10/F07, F12/F10, F14/F12, F16/F14 and A536 65-45-12 for F16, F25, F30, F35, F40.
- Each materials can provide on different process of customer's requirements.

PARTS AND MATERIALS VF-95_SERIES

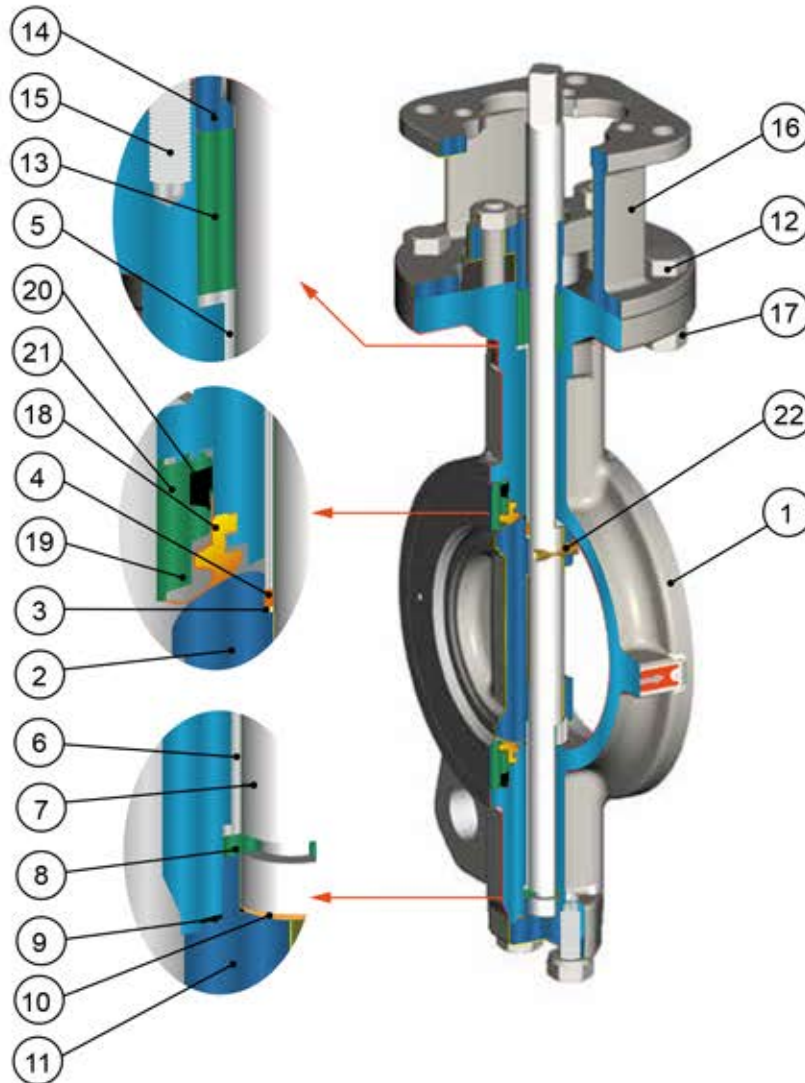

Construction Details

Integral stop Body (1) - To prevent disc from over travel.

Bushing (4-6) - Upper and Lower bearings are constructed of PTFE impregnated 316 SS.

Stem (7) - Design with ISO 5211.

Thrust Ring (8) - Anti blow out shaft and Anti static design.

Gland FLANGE / Packing Gland (14) - One Piece assembly applies even pressure to packing.

Yoke (16) - Investment Cast, per ISO 5211.

Teflon Seat (18) - Pressure assisted to give Bi - directional bubble tight shutoff at all pressures. (Valve must be installed with retaining ring upstream for dead end service.)

Retainer (21) - Patented design of twin threads, ensures an un-inerrupted sealing face. Standard is a 125 - 200 AARH finish and is compatible with both flat and spiral wound gaskets.

* Fugitive Emissions Packing System is available on customer required.

PARTS AND MATERIALS VF-95_SERIES

VF-95_					
No.	Name	Material	Specification		Remark
			JIS	ASTM	
1	BODY	CARBON STEEL	SC480	A216 Gr. WCB	
		STAINLESS STEEL	SCS 13A	A351 Gr. CF8	
			SCS 14A	A351 Gr. CF8M	
2	DISC	STAINLESS STEEL	SCS 16A	A351 Gr. CF3M	Disc edge equipped with hard chrome plated
			SCS 13A	A351 Gr. CF8	
			SCS 14A	A351 Gr. CF8M	
3	SEAL-1	GRAPHITE	SCS 16A	A351 Gr. CF3M	
			SUS 316	A182 Gr. F316	
			SUS 316	A182 Gr. F316	
4	BUSHING	STAINLESS STEEL	SUS 316	A182 Gr. F316	
			SUS 316	A182 Gr. F316	
			SUS 316	A182 Gr. F316	
5	BUSHING	STAINLESS STEEL	SUS 316	A182 Gr. F316	
			SUS 316	A182 Gr. F316	
			SUS 316	A182 Gr. F316	
6	BUSHING	STAINLESS STEEL	SUS 316	A182 Gr. F316	
			SUS 316	A182 Gr. F316	
			SUS 316	A182 Gr. F316	
7	STEM	STAINLESS STEEL	SUS 304	A182 Gr. F304	Stem Equipped With Hard Chrome Plated
			SUS 316	A182 Gr. F316	
			630SS	A564 Gr. 630	
8	THRUST RING	STAINLESS STEEL	XM-19	A479 Gr. XM-19	
			SUS 316	A240 Gr. 316	
			SUS 316	A240 Gr. 316	
9	SEAL-2	GRAPHITE			
10	PACKING	PTFE+316SS			
11	BOTTOM COVER	STAINLESS STEEL	SCS 13A	A351 Gr. CF8	
			SCS 14A	A351 Gr. CF8M	
			SCS 16A	A351 Gr. CF3M	
12	BOLT	CARBON STEEL	SC480	A216 Gr. WCB	
		STAINLESS STEEL	SUS 304	A193 Gr. B8	
13	GLAND PACKING	GRAPHITE			
14	GLAND	STAINLESS STEEL	SCS 14A	A351 Gr. CF8M	
			SCS 16A	A351 Gr. CF3M	
15	STUD	STAINLESS STEEL	SUS 304	A193 Gr. B8	
16	YOKE	DUCTILE IRON	FCD 450	A536 Gr. 65-45-12	*(1)
		CARBON STEEL	SC480	A216 Gr. WCB	
17	NUT	STAINLESS STEEL	SUS 304	A194 Gr. 8	
18	TEFLON SEAT	PTFE+15%GLASS FIBER			-29°C ~ 180°C
		PTFE+15%GRAPHITE			-29°C ~ 210°C
19	METAL SEAT	INCONEL	INCONEL ALLOY	B637 FORGING STOCK	
20	GASKET	GRAPHITE			
21	RETAINER	STAINLESS STEEL	SCS 13A	A351 Gr. CF8	
			SCS 14A	A351 Gr. CF8M	
			SCS 16A	A351 Gr. CF3M	
22	PIN	STAINLESS STEEL	SUS 316	A182 Gr. F316	

Remark:

- No.16 materials A216 Gr. WCB is only available for F07/F05,F10/F07,F12/F10,F14/F12,F16/F14 and A 536 65-45-12 for F16, F25,F30, F35, F40.
- Each materials can provide on different process of customer's requirements.

PARTS AND MATERIALS VF-96_SERIES

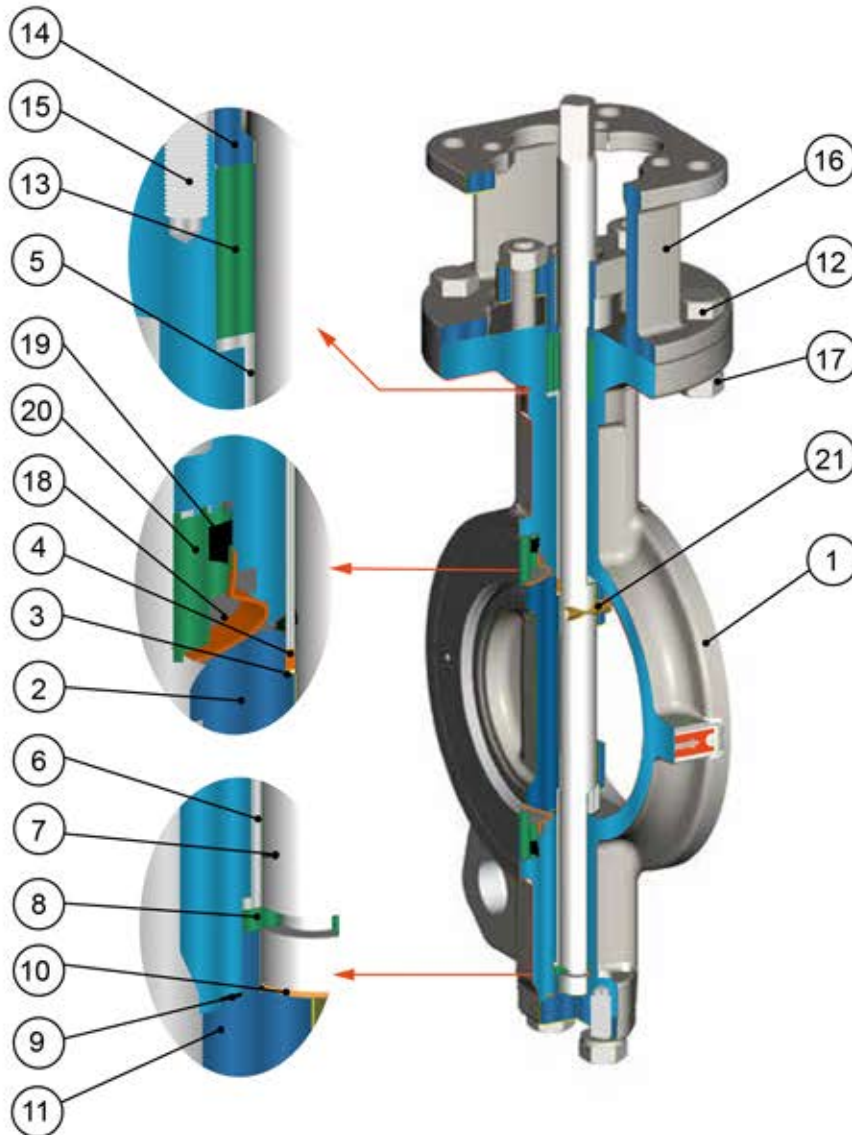

Construction Details

Integral stop Body (1) - To prevent disc from over travel.

Bushing (4-6) - Upper and Lower bearings are constructed of PTFE impregnated 316 SS.

Stem (7) - Design with ISO 5211.

Thrust Ring (8) - Anti blow out shaft and Anti static design.

Packing (13) - Multiply Row of Teflon Chevron.

Gland FLANGE / Packing Gland (14) - One Piece assembly applies even pressure to packing.

Yoke (16) - Investment Cast, per ISO 5211.

Matel Seat (18) - Pressure assisted to give Bi - directional bubble tight shutoff at all pressures.

(Valve must be installed with retaining ring upstream for dead end service.)

Retainer (20) - Patented design of twin threads, ensures an un-inerrupted sealing face. Standard is a 125 - 200 AARH finish and is compatible with both flat and spiral wound gaskets.

* Fugitive Emissions Packing System is available on customer required.

PARTS AND MATERIALS VF-96_SERIES

VF-96_					
No.	Name	Material	Specification		Remark
			JIS	ASTM	
1	BODY	CARBON STEEL	SC 480	A216 Gr. WCB	
			SCS 13A	A351 Gr. CF8	
		STAINLESS STEEL	SCS 14A	A351 Gr. CF8M	
			SCS 16A	A351 Gr. CF3M	
2	DISC	STAINLESS STEEL	SCS 13A	A351 Gr. CF8	Disc edge equipped with hard chrome plated
			SCS 14A	A351 Gr. CF8M	
			SCS 16A	A351 Gr. CF3M	
3	SEAL-1	GRAPHITE			
4	BUSHING	STAINLESS STEEL	SUS 316	A182 Gr. F316	
5	BUSHING	STAINLESS STEEL	SUS 316	A182 Gr. F316	
6	BUSHING	STAINLESS STEEL	SUS 316	A182 Gr. F316	
7	STEM	STAINLESS STEEL	SUS 304	A182 Gr. F304	Stem Equipped With Hard Chrome Plated
			SUS 316	A182 Gr. F316	
			630 SS	A564 Gr. 630	
			XM-19	A479 Gr. XM-19	
8	THRUST RING	STAINLESS STEEL	SUS 316	A240 Gr. 316	
9	SEAL-2	GRAPHITE			
10	PACKING	PTFE+316SS			
11	BOTTOM COVER	STAINLESS STEEL	SCS 13A	A351 Gr. CF8	
			SCS 14A	A351 Gr. CF8M	
			SCS 16A	A351 Gr. CF3M	
12	BOLT	CARBON STEEL	SC 480	A216 Gr. WCB	
		STAINLESS STEEL	SUS 304	A193 Gr. B8	
13	GLAND PACKING	GRAPHITE			
14	GLAND	STAINLESS STEEL	SCS 13A	A351 Gr. CF8	
			SCS 14A	A351 Gr. CF8M	
15	STUD	STAINLESS STEEL	SUS 304	A193 Gr. B8	
16	YOKE	DUCTILE IRON	FCD 450	A536 Gr. 65-45-12	*(1)
		CARBON STEEL	SC 480	A216 Gr. WCB	
17	NUT	STAINLESS STEEL	SUS 304	A194 Gr. 8	
18	METAL SEAT	INCONEL	INCONEL ALLOY	B637 FORGING STOCK	
19	GASKET	GRAPHITE			
20	RETAINER	STAINLESS STEEL	SCS 13A	A351 Gr. CF8	
			SCS 14A	A351 Gr. CF8M	
			SCS 16A	A351 Gr. CF3M	
21	PIN	STAINLESS STEEL	SUS 316	A182 Gr. F316	

Remark:

- No.16 materials A216 Gr. WCB is only available for F07/F05, F10/F07, F12/F10, F14/F12, F16/F14 and A536 65-45-12 for F16, F25, F30, F35, F40.
- Each materials can provide on different process of customer's requirements.

WAFER TYPE DIMENSION

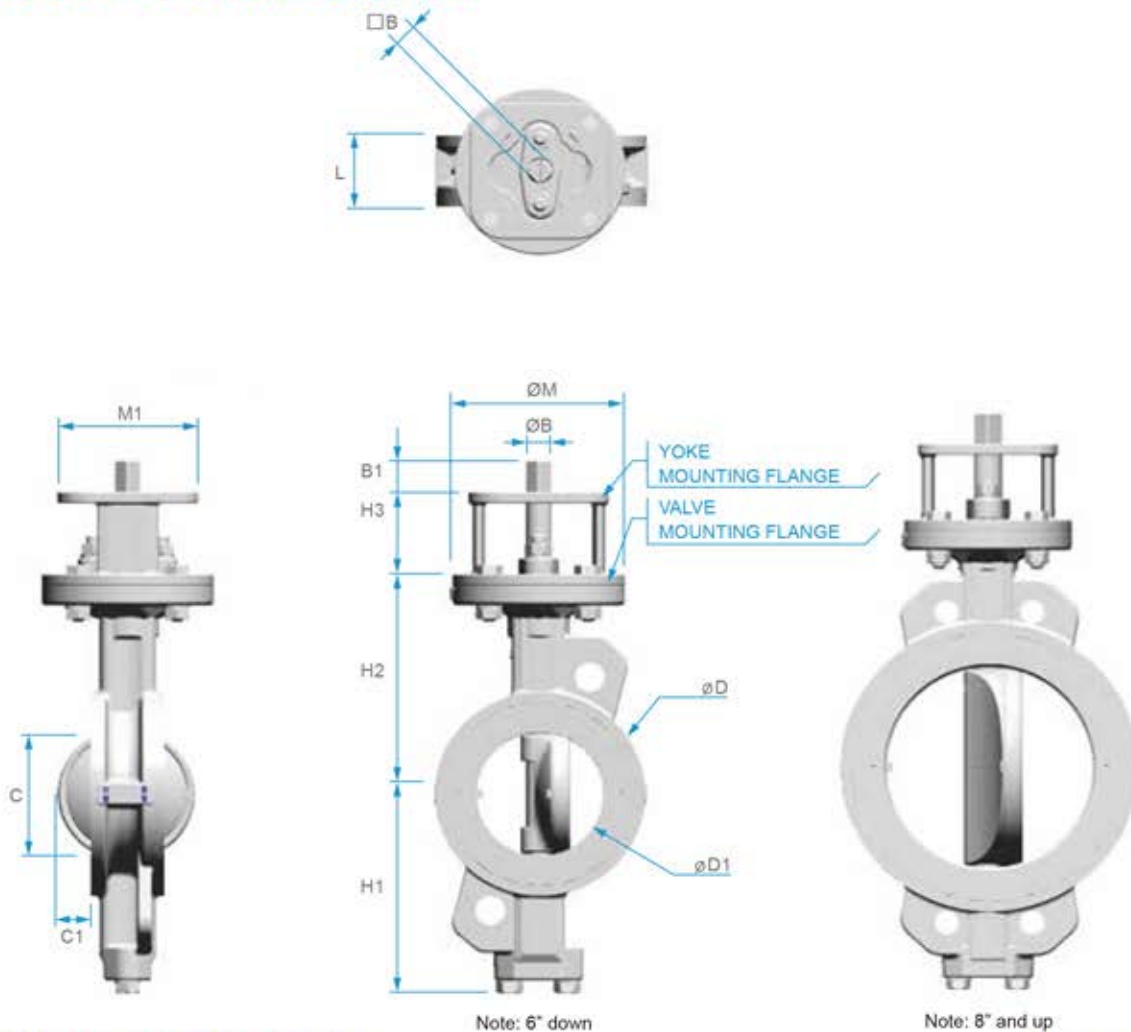

Note: 6" down

Note: 8" and up

VF-91_VF-92_VF-93_Series

Unit : mm

Size	Face to Face	Dimension								Mounting Flange (ISO 5211)				Shaft End			Suitable Pipe Flange	Weight	
		L	H1	H2	H3	φD	φD1	C	C1	VALVE TYPE	φM	YOKE TYPE	M1	φB	□B	B1	★		kg
50	2	43	99	118	60	92	37	49.5	2	F07	90	F07	F05	70	14	11	18	ABCDEFGHK	3.9
65	2.5	46	110	125	60	108	63	62.3	15	F07	90	F07	F05	70	14	11	18	ABCDEFGHJK	4.5
80	3	47	128	140	70	126	78	65.9	22	F10	125	F10	F07	102	18	14	23	ABCDEFGHJK	7
100	4	53	150	157	70	153	95	93	25	F10	125	F10	F07	102	18	14	23	ABCDEFGHJK	9
125	5	57	163	170	70	184	118	120	36	F10	125	F10	F07	102	22	17	23	ABCDEFGHJK	12
150	6	56	176	185	70	212	143	149	50	F10	125	F10	F07	102	22	17	23	ABCDEFGHJK	13.5
200	8	62	206	220	80	268	187.6	196	70	F12	150	F12	F10	125	25	19	28	ABCDEFGHJK	22
250	10	68	238	260	80	326	235.5	243	90	F12	150	F12	F10	125	28	22	28	ABCDEFGHJK	32
300	12	78	269	290	100	375	282	289	106	F14	175	F14	F12	160	35	27	28	ABCDEFGHJK	48
350	14	78/92	306	326	100	416	322	329	125	F14	175	F14	F12	160	36	27	37	ABCDEFGHJK	66
400	16	102	342	370	120	476	371	377	140	F16	210	F16	F14	195	48	36	47	ABCDEFGHJK	107
450	18	114	370	395	120	534	418	423	157	F16	210	F16	F14	195	48	36	47	ABCDEFGHJK	130
500	20	127	399	430	120	588	466	471	177	F16	210	F16	F14	195	60	46	56	ABCDEFGHJK	163
600	24	154	455	490	150	692	570	572	210	F25	300	F16	-	300	60	46	56	ABCDEFJK	278
600	24	154	455	490	150	692	570	572	210	F25	300	F25	-	300	60	46	56	ABCDEFJK	278

★ A : ASME 150LB B : ISO PN10 C : ISOPN16 D : ISO PN20 E : ISO PN25 F : JIS 10K G : JIS 16K H : 20K
K : B.S.10 TABLE E

Pipe limit size > C

*Other dimensions please consult with Value Valves.

Size 50~80



Size 100~150



Size 200~300



Size 350~500



Size 600



LUG TYPE DIMENSION

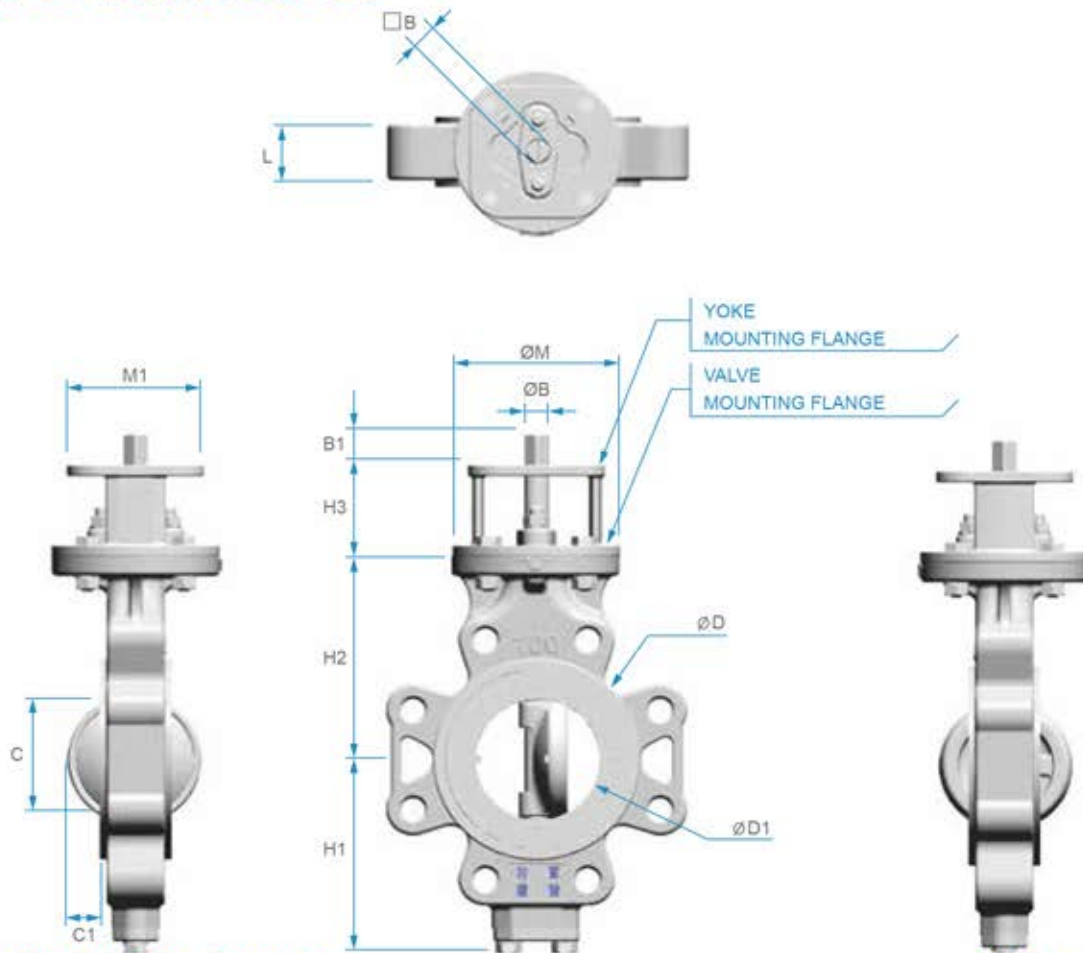

VF-91_VF-92_VF-93_Series

Unit : mm

Size	Face to Face	Dimension									Mounting Flange (ISO 5211)				Shaft end			Suitable Pipe Flange	Weight
		L	H1	H2	H3	ϕD	$\phi D1$	C	C1	TYPE	ϕM	TYPE	M1	ϕB	$\square B$	B1	★		
50	2	43	99	118	60	92	37	49.5	2	F07	90	F07	F05	70	14	11	18	ABCDEFK	4.9
65	2.5	46	110	125	60	108	63	62.3	15	F07	90	F07	F05	70	14	11	18	ABCDEFGHK	5.5
80	3	47	128	140	70	126	78	65.9	22	F10	125	F10	F07	102	18	14	23	ABCDEFGHK	8.5
100	4	53	150	157	70	153	95	93	25	F10	125	F10	F07	102	18	14	23	ABCDEFGHK	14
125	5	57	163	170	70	184	118	120	36	F10	125	F10	F07	102	22	17	23	ABCDEFGHK	18
150	6	56	176	185	70	212	143	149	50	F10	125	F10	F07	102	22	17	23	ABCDEFGHK	19.5
200	8	62	206	220	80	268	188	196	70	F12	150	F12	F10	125	25	19	28	ABCDEFGHK	31
250	10	68	238	260	80	326	236	243	90	F12	150	F12	F10	125	28	22	28	ABCDEFGHK	47
300	12	78	269	290	100	375	282	289	106	F14	175	F14	F12	160	35	27	28	ABCDEFGHK	67
350	14	78/92	306	326	100	416	322	329	125	F14	175	F14	F12	160	36	27	37	ABCDEFGHK	81
400	16	102	342	370	120	476	371	377	140	F16	210	F16	F14	195	48	36	47	ABCDEFGHK	143
450	18	114	370	395	120	534	418	423	157	F16	210	F16	F14	195	48	36	47	ABCDEFGHK	163
500	20	127	399	430	120	588	466	471	177	F16	210	F16	F14	195	60	46	56	ABCDEFGHK	230
600	24	154	455	490	150	692	570	572	210	F25	300	F16	-	300	60	46	56	ABCDE	377
600	24	154	455	490	150	692	570	572	210	F25	300	F25	-	300	60	46	56	ABCDE	377

★ A: ASME 150LB B: ISO PN10 C: ISO PN16 D: ISO PN20 E: ISO PN25 F: JIS 10K G: JIS 16K H: 20K K: B.S. 10
TABLE E

Pipe limit size > C

*Other dimensions please consult with Value Valves.

Size 50~80



Size 100~125



Size 150~200



Size 250~350



Size 400~450



Size 500~600



WAFER TYPE DIMENSION

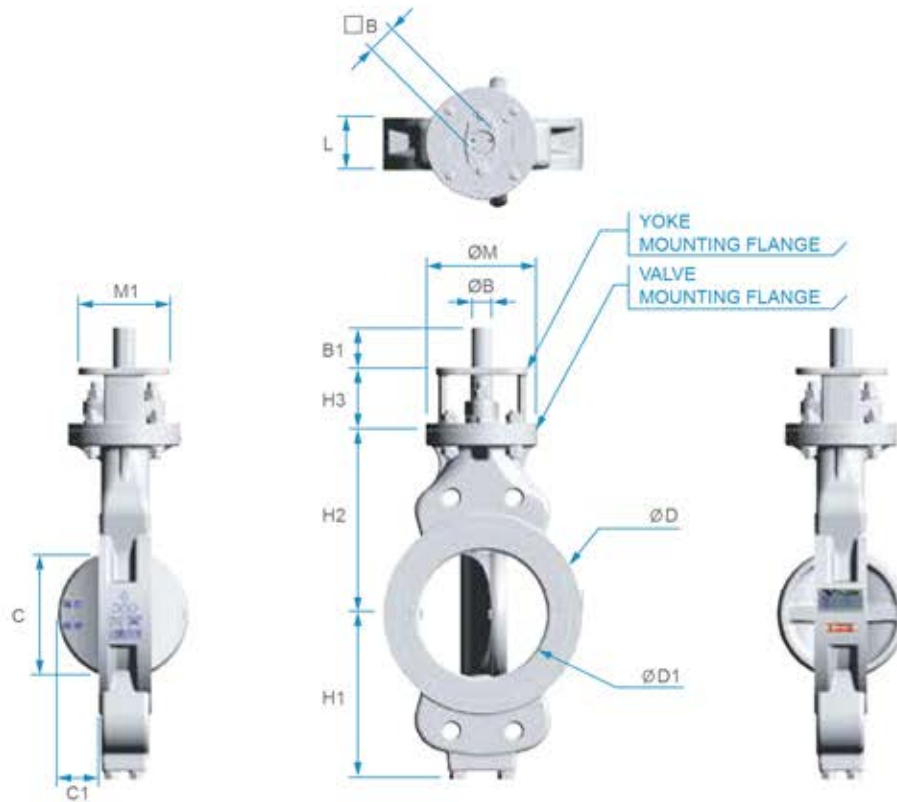

VF-94_VF-95_VF-96_Series

Unit : mm

Size	Face to Face	Dimensions								Mounting Flange (ISO 5211)				Shaft End				Suitable Pipe Flange	Weight	
		L	H1	H2	H3	φD	φD1	C	C1	VALVE		YOKE		φB	□B	B1	KEY			★
mm	Inch	L	H1	H2	H3	φD	φD1	C	C1	Type	φM	Type	M1	φB	□B	B1	KEY	★	kg	
65	2.5	46	110	125	60	108	63	62.3	15	F07	90	F07	F05	70	14	11	18	-	LMN	5
80	3	47	128	140	70	126	78	65.9	22	F10	125	F10	F07	102	18	14	23	-	LMNO	7
100	4	53	150	157	70	153	95	93	25	F10	125	F10	F07	102	18	14	23	-	LMNO	9
125	5	57	163	170	70	184	118	120	36	F10	125	F10	F07	102	22	17	23	-	LMN	12
150	6	59	185	205	70	222	145	142	45	F10	125	F10	F07	102	25	-	45	8*8	LMNO	24
200	8	73	230	260	80	268	185	187	60	F12	150	F12	F10	125	32	-	55	8*8	LMNO	37
250	10	83	266	295	100	326	233	234	79	F14	175	F14	F12	160	38	-	60	10*8	LMN	54
300	12	92	300	325	100	381	280	279	97	F14	175	F14	F12	160	45	-	65	12*8	LMNOP	76
350	14	117	330	365	120	416	318	312	105	F16	210	F16	F14	195	50	-	80	16*10	LMN	109
400	16	133	368	400	120	482	370	359	122	F16	210	F16	F14	195	60	-	80	18*12	LMNOP	134
450	18	149	385	440	150	550	413	403	137	F16	210	F16	F14	195	65	-	90	18*12	LMN	213
500	20	159	427	470	150	592	466	446	157	F25	300	F25	-	300	75	-	110	20*12	LMN	276
600	24	181	516	563	150	725	566	522	196	F30	350	F30	-	350	80	-	120	24*16	LMN	451

★ L : ASME 300LB M : ISO PN40 N : ISO PN50 O : JIS 30K P : JIS 40K

Pipe limit size > C

*VF-95_ and VF-96_ Series, 14" and up please contact to Value Valves.

Size 65~80



Size 100~125



Size 150~400



Size 450~600



LUG TYPE DIMENSION

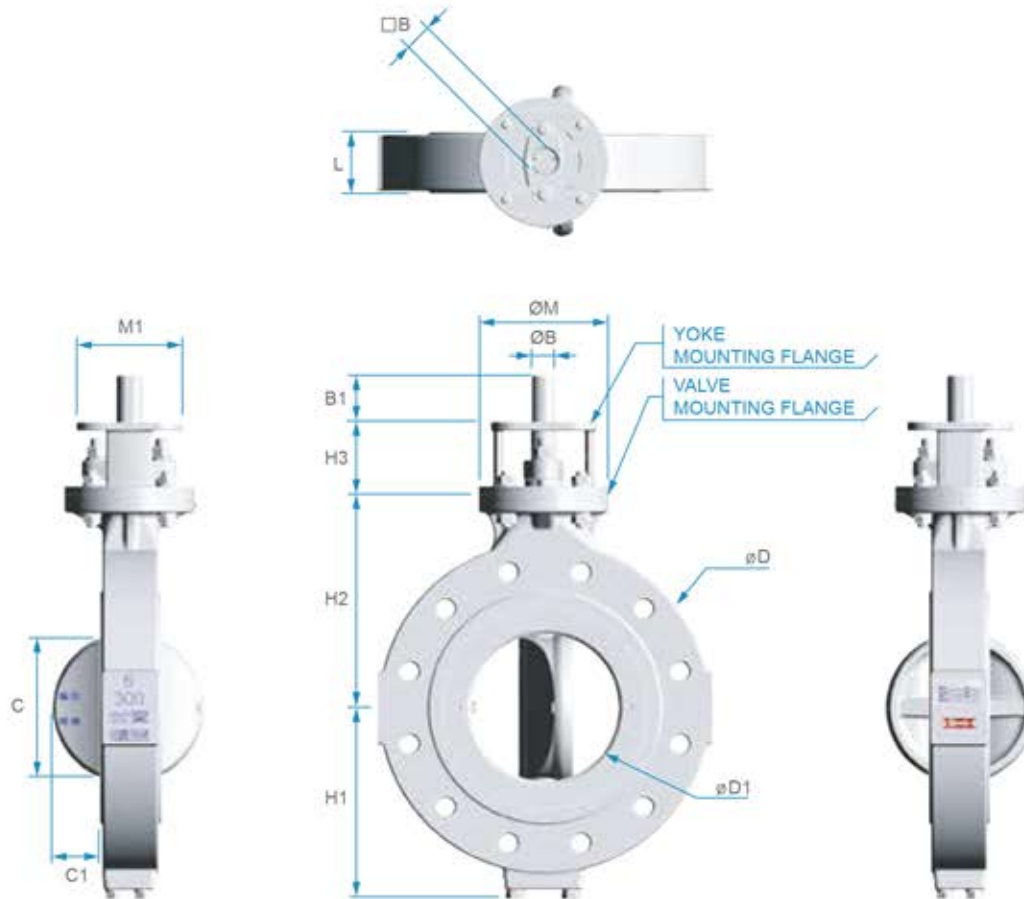

VF-94_/VF-95_/VF-96_Series

Unit : mm

Size	Face to Face	Dimensions								Mounting Flange (ISO 5211)				Shaft End			Suitable Pipe Flange	Weight		
		L	H1	H2	H3	φD	φD1	C	C1	Type	φM	Type	M1	φB	□B	B1			KEY	★
65	2.5	46	110	125	60	108	63	62.3	15	F07	90	F07	F05	70	14	11	18	-	LMN	7
80	3	47	128	140	70	126	78	65.9	22	F10	125	F10	F07	102	18	14	23	-	LMN	11
100	4	53	150	157	70	153	95	93	25	F10	125	F10	F07	102	18	14	23	-	LMN	14
125	5	57	163	170	70	184	118	120	36	F10	125	F10	F07	102	22	17	23	-	LMN	18
150	6	59	185	205	70	320	145	142	45	F10	125	F10	F07	102	25	-	45	8*8	LMN	35
200	8	73	230	260	80	381	185	187	60	F12	150	F12	F10	125	32	-	55	8*8	LMNO	57
250	10	83	266	295	100	445	233	234	79	F14	175	F14	F12	160	38	-	60	10*8	LMN	90
300	12	92	300	325	100	521	280	279	97	F14	175	F14	F12	160	45	-	65	12*8	LMNOP	139
350	14	117	330	365	120	585	318	312	105	F16	210	F16	F14	195	50	-	80	16*10	LMN	205
400	16	133	368	400	120	648	370	359	122	F16	210	F16	F14	195	60	-	80	18*12	LMN	209
450	18	149	385	440	150	712	413	403	137	F16	210	F16	F14	195	65	-	90	18*12	LMN	370
500	20	159	427	470	150	775	466	446	157	F25	300	F25	-	300	75	-	110	20*12	LMN	496
600	24	181	516	563	150	915	566	522	196	F30	350	F30	-	350	80	-	120	24*16	LMN	643

★ L : ASME 300LB M : ISO PN40 N : ISO PN50 O : JIS 30K P : JIS 40K

Pipe limit size > C

*VF-95_ and VF-96_Series, 14" and up please contact to Value Valves.

Size 65~125



Size 150~200



Size 250~300



Size 350~400



Size 450~600



FLANGE TYPE DIMENSION

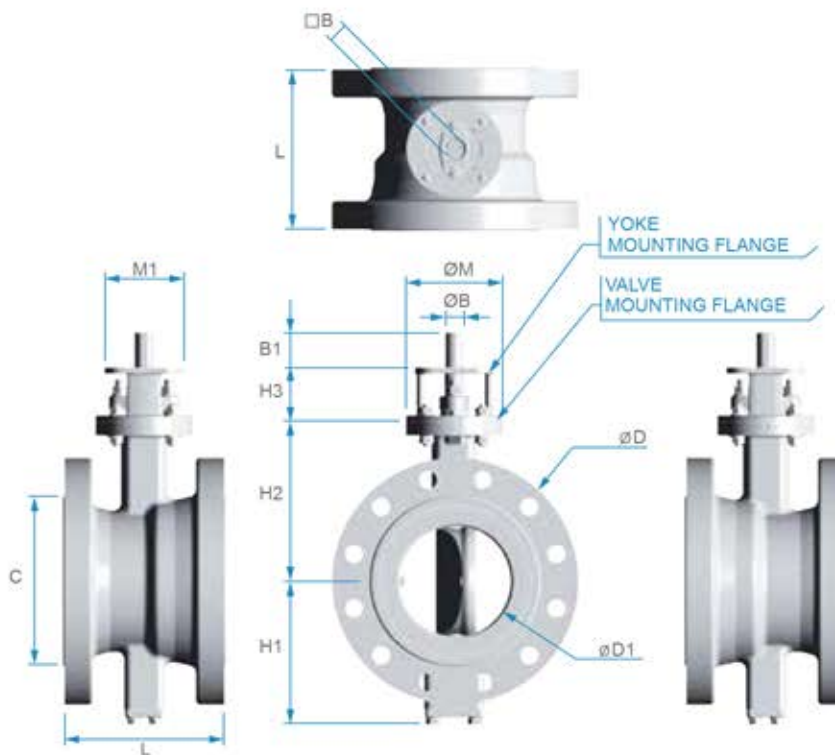

VF-916/VF-917 Series

Unit : mm

Size		Face to Face		Dimensions					Mounting Flange (ISO 5211)				Shaft End			Suitable Pipe Flange		Weight	
		L		H1	H2	H3	φD	φD1	Type	φM	YOKE TYPE		φB	□B	B1	★	916	917	
mm	inch	916	917														kg		
80	3	114	180	121	140	70	204	78	F10	125	F10	F07	102	14	11	18	ABCE	10.4	14.8
100	4	127	190	150	157	70	230	104	F10	125	F10	F07	102	18	14	23	ABCDFGHK	16.3	22.5
125	5	140	200	163	170	70	255	125	F10	125	F10	F07	102	22	17	23	ABCDFK	21.1	27.7
150	6	140	210	176	185	70	280	150	F10	125	F10	F07	102	22	17	23	ABCDEF	27.3	33.8
200	8	152	230	206	220	80	350	200	F12	150	F12	F10	125	25	19	28	ABCDFGHK	43.1	55.5
250	10	165	250	238	260	80	406	255	F12	150	F12	F10	125	28	22	28	ABCDFK	67.7	71.6
300	12	178	270	269	290	100	485	300	F14	DF	F14	F12	160	35	27	28	ABCDFGHK	105.6	117.4
350	14	190	290	306	326	100	535	340	F14	175	F14	F12	160	36	27	37	ABCDFK	135.9	147.1
400	16	216	310	342	370	120	599	390	F16	210	F16	F14	195	48	36	47	ABCDFK	191.7	213.2
450	18	222	330	370	395	120	635	440	F16	210	F16	F14	195	48	36	47	ABCDF	224.1	237.6
500	20	229	350	399	430	120	700	480	F16	210	F16	F14	195	60	46	56	ABCDF	265.8	292.2
600	24	267	390	455	490	150	815	590	F25	300	F25	-	300	60	46	56	ABCDF	421.8	454.2

★ A : ASME 150LB B : ISO PN10 C : ISOPN16 D : ISO PN20 E : ISO PN25 F : JIS 10K G : JIS 16K H : 20K K.B.S.10 TABLE E

Pipe limit size > C

*Other dimensions please consult with Value Valves.

FLANGE TYPE DIMENSION

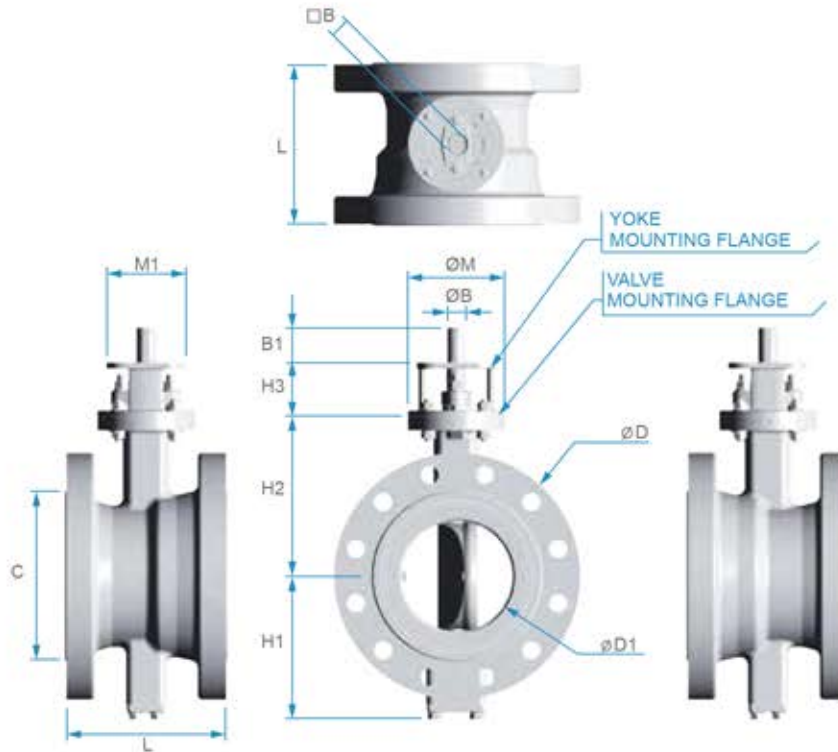

VF-947 Series

Unit : mm

Size	Face to Face	Dimensions						Mounting Flange (ISO 5211)				Shaft End			Suitable Pipe Flange	Weight		
		L	H1	H2	H3	φD	φD1	VALVE		YOKE		φB	φB	KEY	B1	★	kg	
80	3	180	121	140	70	214	78	F10	125	F10	F07	102	14	11	-	18	LM	19
100	4	190	149.5	157	70	254	104	F10	125	F10	F07	102	18	14	-	23	LMO	32
125	5	200	163	170	70	280	125	F10	125	F10	F07	102	22	17	-	23	LMO	40
150	6	210	185	205	70	318	150	F10	125	F10	F07	102	25	-	8*8	45	L	56
200	8	230	230	260	80	385	200	F12	150	F12	F10	125	30	-	8*8	55	LMO	90
250	10	250	266	295	100	445	255	F14	175	F14	F12	160	35	-	10*8	60	LO	136
300	12	270	300	325	100	521	300	F14	175	F14	F12	160	38	-	12*8	65	LMO	184
350	14	290	330	365	120	585	340	F16	210	F16	F14	195	48	-	16*10	80	LMO	254
400	16	310	368	400	120	648	390	F16	210	F16	F14	195	60	-	18*12	80	L	317
450	18	330	385	440	150	712	438	F16	210	F16	F14	195	70	-	18*12	90	LMO	444
500	20	350	427	470	150	775	485	F25	300	F25	-	300	80	-	20*12	110	LMO	558
600	24	390	516	563	150	915	590	F30	350	F30	-	350	90	-	24*16	120	LMO	822

★ L : ASME 300LB M : ISO PN40 N : ISO PN50 O : JIS 30K P : JIS 40K

Pipe limit size > C

*Other dimensions please consult with Value Valves.

BOLTING & GASKET FOR INSTALLATION

VF-91_VF-92_VF-93_Series

Unit : mm

SIZE		PN10					PN16					PN20					PN25								
mm	inch	BOLT SIZE	A	B	C	D	T	BOLT SIZE	A	B	C	D	T	BOLT SIZE	A	B	C	D	T	BOLT SIZE	A	B	C	D	T
50	2	M16	135	120	65	45	20	M16	130	120	65	45	20	M16	130	125	70	50	23	M16	130	125	70	50	22
65	2.5	M16	135	120	70	45	20	M16	135	120	70	45	20	M16	140	125	70	50	23	M16	140	125	70	50	22
80	3	M16	135	120	70	45	20	M16	135	120	70	45	20	M16	145	130	75	50	24	M16	145	130	75	50	24
100	4	M16	145	130	75	50	22	M16	145	130	75	50	22	M16	150	135	75	55	24	M20	160	140	80	55	24
125	5	M16	150	135	75	50	22	M16	150	135	75	50	22	M20	165	140	80	55	24	M24	180	155	90	60	26
150	6	M20	165	140	80	55	24	M20	165	140	80	55	24	M20	165	145	85	55	26	M24	180	155	90	60	28
200	8	M20	165	145	85	55	24	M20	165	145	85	55	24	M20	175	155	90	60	29	M24	190	165	95	65	30
250	10	M20	180	160	90	60	26	M24	190	165	95	60	26	M24	200	175	100	70	31	M27	210	180	105	70	32
300	12	M20	190	170	95	65	26	M24	205	180	100	70	28	M24	210	185	105	70	32	M27	220	195	110	75	34
350	14	M20	190	170	95	65	26	M24	210	185	105	70	30	M27	225	195	110	75	35	M30	235	205	120	80	38
400	16	M24	225	200	110	70	26	M27	240	215	120	80	32	M27	250	225	125	85	37	M33	270	240	135	95	40
450	18	M24	240	215	120	75	28	M27	270	240	135	90	40	M30	275	240	135	95	40	M33	300	265	150	105	48
500	20	M24	255	230	125	75	28	M30	300	270	150	100	44	M30	295	265	150	95	43	M33	310	280	155	105	48
600	24	M27	300	270	150	85	34	M33	355	320	175	110	54	M33	340	310	170	105	48	M36	370	330	185	120	58

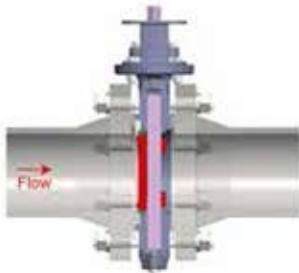

The seals flow can be executed in both directions.

The following advantages can be assured while the suggested flow directions is used.

- Minimal start-up torque.
- Reduced seat wear.
- No direct contact between the fluid and the seat.

VF-91_VF-92_VF-93_Series

Unit : mm

SIZE		ASME B16.5 150LB					JIS 10K					JIS 16K & 20K					B.S. 10 TABLE E								
mm	inch	BOLT SIZE	A	B	C	D	T	BOLT SIZE	A	B	C	D	T	SIZE BOLT	A	B	C	D	T	BOLT SIZE	A	B	C	D	T
50	2	5/8"	135	125	65	50	20	M16	130	115	65	45	16	M16	130	115	65	45	16	5/8"	120	110	60	40	10
65	2.5	5/8"	140	125	70	50	22	M16	130	115	65	45	18	M16	145	115	65	45	18	5/8"	120	110	60	40	14
80	3	5/8"	145	130	70	50	24	M16	135	115	65	45	18	M20	155	125	70	50	20	5/8"	120	110	60	40	14
100	4	5/8"	150	135	75	55	24	M16	140	120	70	50	18	M20	165	135	75	55	22	5/8"	135	120	65	45	17
125	5	3/4"	165	145	80	55	24	M20	155	135	80	55	20	M22	165	140	80	55	22	5/8"	140	125	70	50	17
150	6	3/4"	165	145	85	55	25	M20	160	140	80	55	22	M22	175	145	80	55	24	3/4"	145	130	70	50	17
200	8	3/4"	175	155	90	60	28	M20	165	140	80	55	22	M22	195	150	85	60	26	3/4"	152	135	75	50	19
250	10	7/8"	190	170	95	65	30	M22	180	155	90	60	24	M24	210	170	95	65	28	3/4"	165	150	85	55	22
300	12	7/8"	205	180	100	70	32	M22	190	165	95	60	24	M24	230	185	100	70	30	7/8"	185	170	95	65	25
350	14	1"	220	195	110	75	35	M22	195	170	95	65	26	M30	260	200	110	80	34	7/8"	195	175	95	70	29
400	16	1"	245	220	125	80	37	M24	230	205	115	70	28	M30	275	230	130	85	38	7/8"	225	205	110	75	32
450	18	1-1/8"	270	240	135	90	40	M24	245	220	120	75	30	M30	295	245	135	90	40	7/8"	240	225	120	80	35
500	20	1-1/8"	290	260	145	90	43	M24	255	230	130	75	30	M30	345	265	145	95	42	7/8"	260	245	130	80	38
600	24	1-1/4"	340	305	170	100	48	M30	300	270	150	85	32	M36	310	270	150	105	46	1-1/8"	325	300	165	100	48

*Other dimensions please consult with Value Valves.

BOLTING & GASKET FOR INSTALLATION

Wafer Type

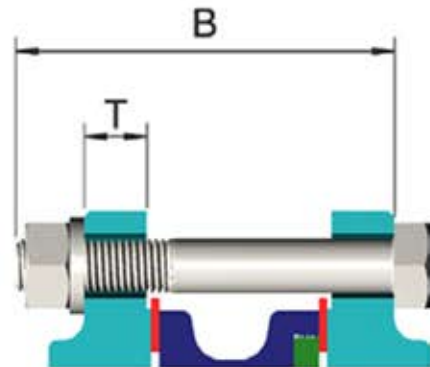
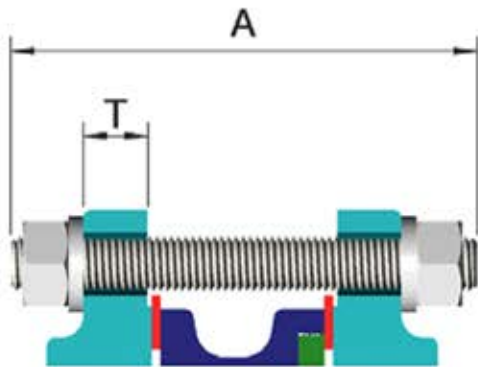

Lug Type

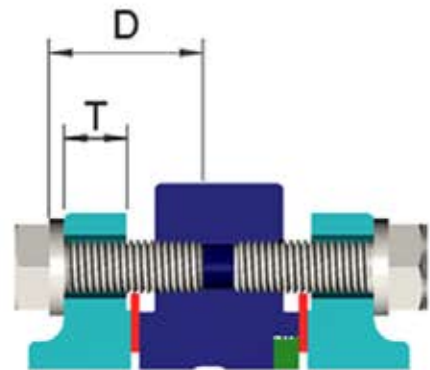
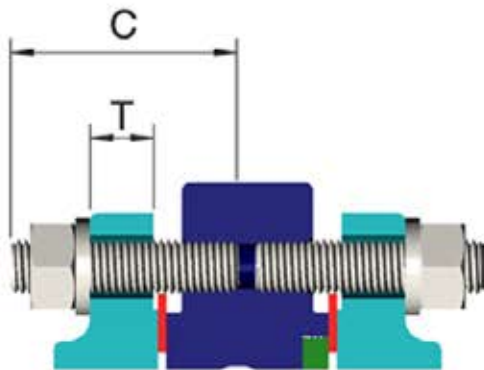

VF-94_/VF-95_/VF-96_ Series

Unit : mm

SIZE		ASME B16.5 300LB						PN40					PN50						
mm	inch	BOLT SIZE	A	B	C	D	T	BOLT SIZE	A	B	C	D	T	BOLT SIZE	A	B	C	D	T
65	2.5	3/4"	160	135	80	55	23	M16	140	120	65	45	22	M20	155	130	80	55	26
80	3	3/4"	165	140	85	60	30	M16	145	125	70	50	24	M20	165	140	80	55	29
100	4	3/4"	180	155	85	60	34	M20	160	135	75	50	24	M20	175	150	85	60	32
125	5	3/4"	190	165	90	65	37	M24	180	150	90	60	26	M20	185	160	90	65	35
150	6	3/4"	195	170	90	65	39	M24	185	155	90	60	28	M20	190	165	90	65	37
200	8	7/8"	220	195	100	75	43	M27	215	185	105	75	34	M24	225	195	105	75	42
250	10	1"	260	230	120	90	50	M30	240	210	115	80	38	M27	255	225	120	90	48
300	12	1-1/8"	280	245	130	95	53	M30	255	220	115	80	42	M30	275	240	125	90	51
350	14	1-1/8"	310	275	130	95	56	M33	295	260	125	90	46	M30	305	270	130	95	54
400	16	1-1/4"	335	300	140	105	59	M36	325	285	140	100	50	M33	330	295	140	105	58
450	18	1-1/4"	360	325	145	110	63	M36	355	315	145	105	57	M33	355	320	140	105	61
500	20	1-1/4"	375	340	145	110	66	M39	370	330	150	110	57	M33	370	335	145	110	64
600	24	1-1/2"	420	380	165	125	75	M45	430	385	175	130	72	M39	415	375	165	125	70

*Other dimensions please consult with Value Valves.



SPECIAL OFFER

The heating jacket and flashing nozzles designed as below pictures showed, which designed to apply the temperature changes and prevent fluid crystallization.

Value Valves VF-9 series, high performance double eccentric butterfly valve can be provided on customer's requirements. More detail please consult with us at

sales@valuevalves.com.tw

APPLICABLE STANDARDS

- Body Style: Wafer type, Lug type, Flange type
- Body Shell Thickness: ASME B16.34
- Mounting: ISO 5211
- Design & Pressure: ASME B16.34, 16.5
- Face to Face : API 609, ISO 5752
- Inspection and Testing:
ISO 5208, API 598, MSS SP-61, MSS SP-68
- Fire Safe: API 607
- VOC: ANSI/ISA-SP-93, TA-Luft, ISO 15848-1
- Standard Marketing System: MSS-SP-25
- EX Certificate: ATEX 94/9/CE Group II Category 2 GD
- Leakage Class: ANSI FCI 70-2-2006 Table 1 CLASS V,
ISO 5208 Rate A, ANSI/ISA-SP-93
- Safety Integrity Level 3 (SIL 3) : IEC 61508-1
- Flange Connection:

ASME B16.5 Class 150/300, ASME B16.47 Class 150/300

(Other flange connection please contacts with Value Valves Co., Ltd.)

*Technical information is only for reference. Value Valves Co., Ltd. reserves the right to change without previous notice.



GENERAL ORDERING INFORMATION

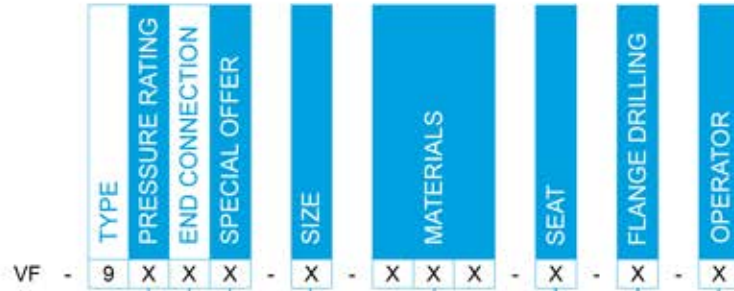

PRESSURE RATING	
1	Teflon Seat
2	150LB Teflon+ SS316 Seat Fire Safe
3	Metal Seat
4	Teflon Seat
5	300LB Teflon+ SS316 Seat Fire Safe
6	Metal Seat

END CONNECTION	
0	WAFER
3	LUG
6	FLANGE (SHORT)
7	FLANGE (LONG)

OPERATOR	
N	BARE SHAFT
G	GEAR BOX
P	PNEUMATIC
E	ELECTRIC
H	HYDRAULIC
L	LEVER

SIZE	mm
02	50
025	65
03	80
04	100
05	125
06	150
08	200
10	250
12	300
14	350
16	400
18	450
20	500
24	600

SPECIAL OFFER	
N	NONE
E	EMISSION
P	INTERNAL POLISHED
L	CRYOGENIC -100°C ~ 50°C (VF-930)
H	WORK TEMP. 350°C ~ 500°C (VF-930)
J	JACKET
0	OTHERS

BODY	DISC	SHAFT
WB WCB	13 CF8	34 A182 F304
13 CF8	14 CF8M	36 A182 F316
14 CF8M	0 OTHER	63 A564 630
0 OTHER		XM XM-19
		0 OTHER

FLANGE DRILLING	
A	ASME B16.5 150LB
B	ISO 7005-1 PN10
C	ISO 7005-1 PN16
D	ISO 7005-1 PN20
E	150LB ISO 7005-1 PN25
F	JIS 10K
G	JIS 16K
H	JIS 20K
K	B.S. 10 Table E
L	ASME B16.5 300LB
M	ISO 7005-1 PN40
N	300LB ISO 7005-1 PN50
O	JIS 30K
P	JIS 40K

OTHER MATERIALS					
BODY		DISC		SHAFT	
LB	LCB	3L	CF3	IN	INCONEL
42	WC6	6L	CF3M	MO	MONEL
3L	CF3	8M	CG8M	HA	HASTALLOY C
6L	CF3M	7L	CG3M	20	ALLOY 20
8M	CG8M	IN	INCONEL	TI	TI
7L	CG3M	MO	MONEL	TT	316TI
IN	INCONEL	HA	HASTALLOY		
MO	MONEL	20	ALLOY20		
HA	HASTALLOY	TI	TI		
20	ALLOY20	TT	316TI		
TI	TI	5A	SS CE3MN		
TT	316TI				
5A	SS CE3MN				

SEAT	
P	PTFE (VF-91_ONLY)
PG	PTFE+15%GRAPHITE (VF-91_94_)
PGF	PTFE+15%GLASS FIBER (VF-91_94_)
P36	PTFE+A240 316 (VF-92_)
PG36	PTFE+15%GRAPHITE+A240 316 (VF-92_)
PF36	PTFE+15%FIBER + A240 316(VF-92_)
PI	PTFE+INCONEL (VF-92_)
PGI	PTFE+15%GRAPHITE+INCONEL (VF-92_95_)
PFI	PTFE+15%FIBER+INCONEL (VF-92_95_)
I	INCONEL (VF-93_96_)

Note: Example VF-910E-08-WB13XM-P-F-N
Shall be a:

High Performance Butterfly Valve(9)
ANSI 150LB Teflon Seat(1) Wafer Type(0)
Emission(E) DN200(08)
WCB Body(WB) CF8 Disc(13)
Shaft in XM-19(XM) Body seat in PTFE(P)
Flange Drilling in JIS10K(F) Bare Shaft(N)

* For any other special offers, please contact Value Valves.