

General Description

Series “F” flow control valves provide precise control of flow and shut-off in one direction, and automatically permit full flow in the opposite direction.

Operation

A two-step needle allows fine adjustment at low flow by using the first three turns of the adjusting knob; the next three turn open the valve to full flow, and also provide standard throttling adjustments.

Features

- The exclusive “Colorflow” color-band reference scale on the valve stem is a great convenience and time-saver in setting the valve originally and in returning it to any previous setting.
- A simple set screw locks the valve on any desired setting.
- A tamperproof option (T) feature is also available to prevent accidental or intentional adjustment of flow setting.

Specifications

Maximum Operating Pressure	Brass: 140 Bar (2000 PSI); except for F1600 brass which is 35 Bar (500 PSI) Steel: 345 Bar (5000 PSI) for 200 thru 1220; 207 Bar (3000 PSI) for all other sizes
Return Check Poppet, Nominal Cracking Pressure	0.4 Bar (5 PSI)
Poppets	Soft seal poppet in brass 200-1020 sizes Solid metal 416 stainless steel poppet on all other sizes and styles
Operating Temperature	-40°C to +121°C (-40°F to +250°F)

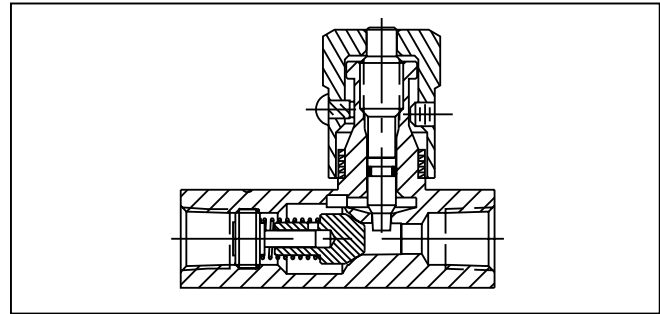
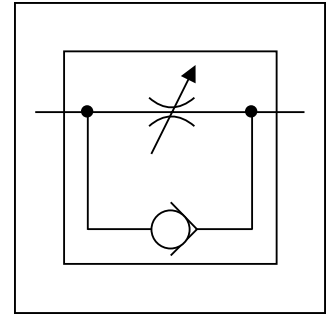

Performance Curves

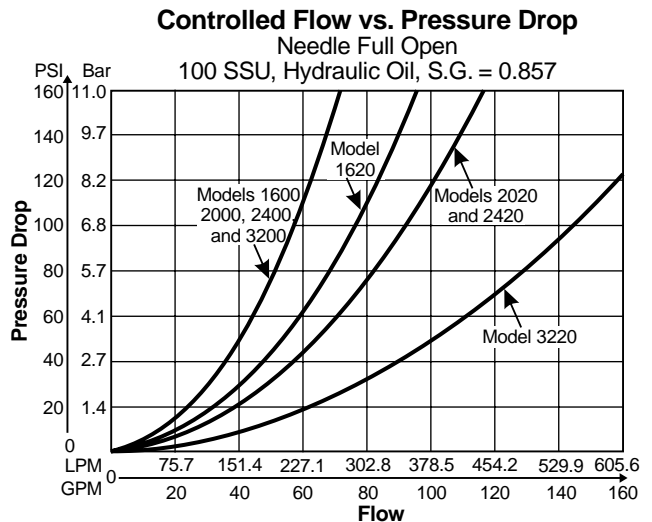
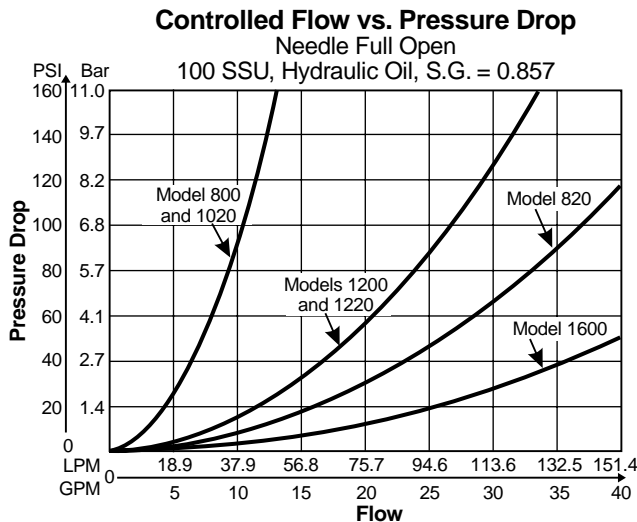
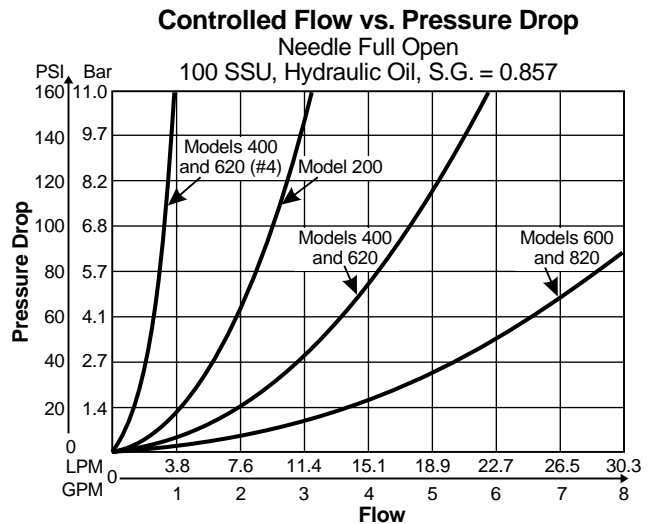

*Inch equivalents for millimeter dimensions are shown in (**)

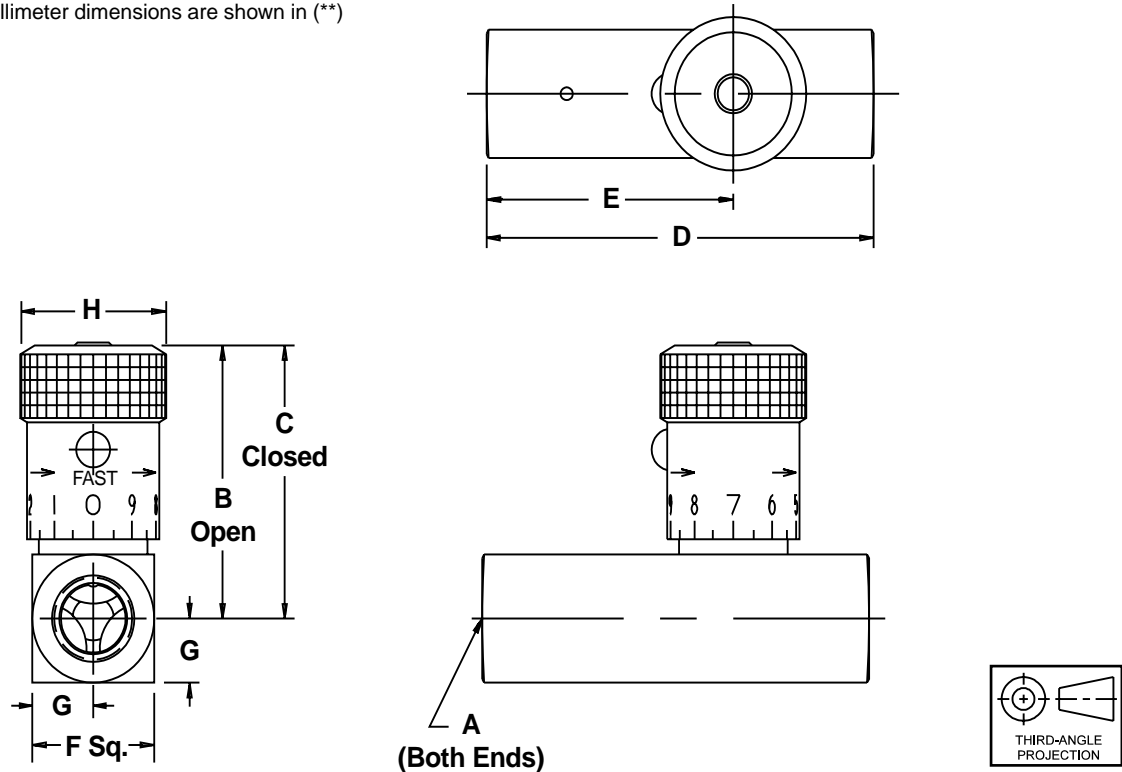

Model Number	Max Flow LPM (GPM)	A	B	C	D	E	F	G	H
F200	11 (3)	1/8-27 NPTF	39.1 (1.54)	35.3 (1.39)	50.8 (2.00)	32.5 (1.28)	16.0 (0.63)	7.9 (0.31)	19.1 (0.75)
F400	19 (5)	1/4-18 NPTF	45.5 (1.79)	40.4 (1.59)	66.8 (2.63)	42.2 (1.66)	20.6 (0.81)	10.4 (0.41)	20.6 (0.81)
F420	11 (3)	7/16-20 UNF #4 SAE	41.4 (1.63)	37.6 (1.48)	68.3 (2.69)	42.9 (1.69)	20.6 (0.81)	10.4 (0.41)	19.1 (0.75)
F600	30 (8)	3/8-18 NPTF	55.4 (2.18)	49.5 (1.95)	69.9 (2.75)	44.5 (1.75)	25.4 (1.00)	12.7 (0.50)	25.4 (1.00)
F620	19 (5)	9/16-18 UNF #6 SAE	47.7 (1.88)	42.7 (1.68)	79.2 (3.12)	48.8 (1.92)	25.4 (1.00)	12.7 (0.50)	20.6 (0.81)
F800	57 (15)	1/2-14 NPTF	68.6 (2.70)	61.5 (2.42)	87.4 (3.44)	56.6 (2.23)	31.8 (1.25)	16.0 (0.63)	30.2 (1.19)
F820	30 (8)	3/4-16 UNF #8 SAE	56.9 (2.24)	51.1 (2.01)	88.9 (3.50)	53.8 (2.12)	28.4 (1.12)	14.2 (0.56)	25.4 (1.00)
F1020	57 (15)	7/8-14 UNF #10 SAE	68.6 (2.70)	61.5 (2.42)	101.6 (4.00)	65.0 (2.56)	31.8 (1.25)	15.7 (0.62)	30.2 (1.19)
F1200	95 (25)	3/4-14 NPTF	85.9 (3.38)	71.4 (2.81)	98.6 (3.88)	65.5 (2.58)	38.1 (1.50)	19.1 (0.75)	35.1 (1.38)
F1220	95 (25)	1 1/6-12 UN #12 SAE	85.9 (3.38)	71.4 (2.81)	117.3 (4.62)	76.5 (3.01)	38.1 (1.50)	19.1 (0.75)	35.1 (1.38)
F1600	151 (40)	1-11 1/2 NPTF	123.7 (4.87)	106.9 (4.21)	127.0 (5.00)	81.8 (3.22)	44.5 (1.75)	22.4 (0.88)	47.8 (1.88) *
F1620	151 (40)	1 5/16-12 UN #16 SAE	130.8 (5.15)	114.0 (4.49)	142.7 (5.62)	88.9 (3.50)	57.2 (2.25)	28.4 (1.12)	47.8 (1.88) *
F2000	265 (70)	1 1/4-11 1/2 NPTF	130.0 (5.12)	113.3 (4.46)	143.0 (5.63)	98.6 (3.88)	57.2 (2.25)	28.7 (1.13)	47.8 (1.88) *
F2020	265 (70)	1 5/8-12 UN #20 SAE	140.2 (5.52)	123.4 (4.86)	165.1 (6.50)	108.0 (4.25)	69.9 (2.75)	35.1 (1.38)	47.8 (1.88) *
F2400	379 (100)	1 1/2-11 1/2 NPTF	136.4 (5.37)	119.6 (4.71)	143.0 (5.63)	113.5 (4.47)	69.9 (2.75)	35.1 (1.38)	47.8 (1.88) *
F2420	379 (100)	1 7/8-12 UN-2B #24 SAE	143.5 (5.65)	126.7 (4.99)	184.2 (7.25)	127.0 (5.00)	76.2 (3.00)	38.1 (1.50)	47.8 (1.88) *
F3200	568 (150)	2-11 1/2 NPTF	146.1 (5.75)	129.3 (5.09)	165.1 (6.50)	134.9 (5.31)	88.9 (3.50)	44.5 (1.75)	47.8 (1.88) *
F3220	568 (150)	2 1/2-12 UN #32 SAE	163.6 (6.44)	139.4 (5.49)	228.6 (9.00)	155.7 (6.13)	101.6 (4.00)	50.8 (2.00)	47.8 (1.88) *

* = Hex



Ordering Information

Flow Control Valves Series F

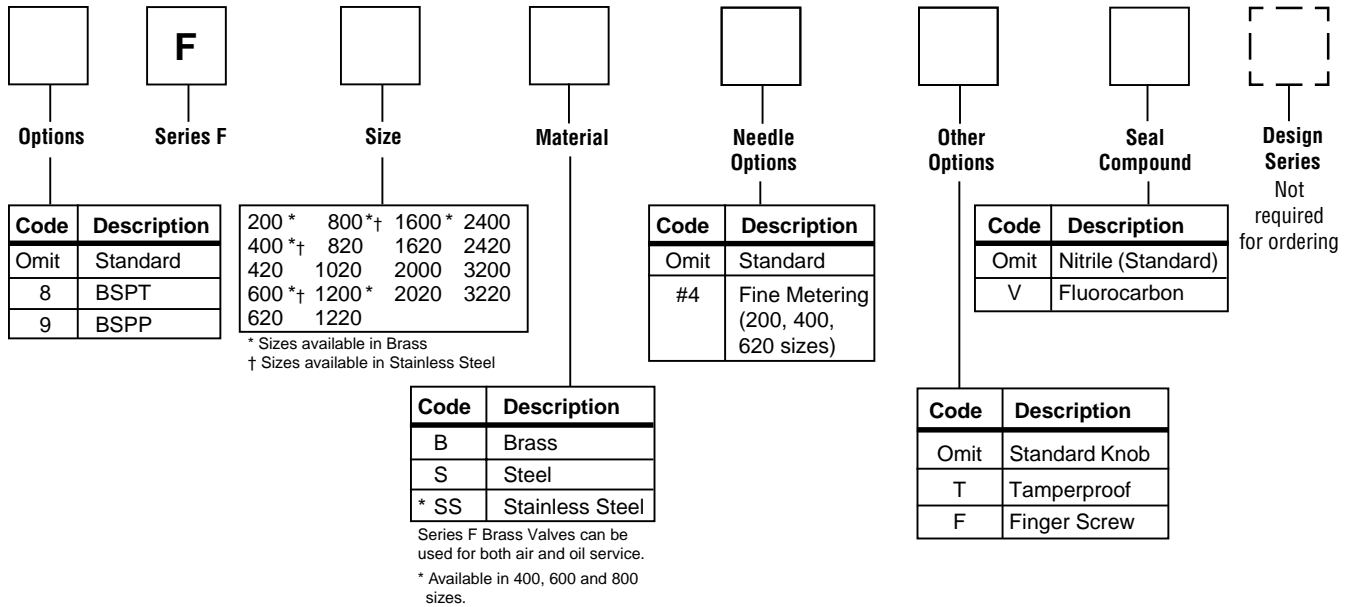

Model Number	Weight Kg (lbs.)	Model Number	Weight Kg (lbs.)
F200	0.1 (0.3)	F1220	1.2 (2.6)
F400	0.2 (0.5)	F1600	2.3 (5.1)
F420	0.2 (0.5)	F1620	2.3 (5.1)
F600	0.3 (0.7)	F2000	3.7 (8.1)
F620	0.3 (0.6)	F2020	3.7 (8.1)
F800	0.7 (1.5)	F2400	4.6 (10.2)
F820	0.5 (1.0)	F2420	4.6 (10.2)
F1020	0.8 (1.8)	F3200	7.9 (17.4)
F1200	1.2 (2.6)	F3220	7.9 (17.4)



General Description

Flow control valves provide precision metering in one direction and allow unrestricted free flow in the opposite direction.

Operation

A two-step needle allows fine adjustment at low flow by using the first three turns of the adjusting knob; the next three turn open the valve to full flow, and also provide standard throttling adjustments.

Features

- Meets ISO 6149 standards.
- Hard metric dimensions.
- Reliable leak-free performance — straight thread port with O-Ring sealing.
- Global interchangeability.

Specifications

Maximum Operating Pressure	M16 x 1.5	345 Bar (5000 PSI)
	M18 x 1.5	345 Bar (5000 PSI)
	M22 x 1.5	345 Bar (5000 PSI)
	M27 x 2.0	207 Bar (3000 PSI)
Maximum Flow	M16 x 1.5	19 LPM (5 GPM)
	M18 x 1.5	30 LPM (8 GPM)
	M22 x 1.5	57 LPM (15 GPM)
	M27 x 2.0	95 LPM (25 GPM)
	M33 x 2.0	151 LPM (40 GPM)
	M42 x 2.0	265 LPM (70 GPM)
	M48 x 2.0	379 LPM (100 GPM)
Material	Body	ASTM 12L14 Carbon Steel
	Knob	ASTM 12L14 Carbon Steel
	Needle	ASTM 416 Stainless Steel
	Poppet	ASTM 416 Stainless Steel
	Retainer	ASTM 416 Stainless Steel
	Spring	ASTM 316 Stainless Steel
	Seals	Nitrile — Standard
Fluorocarbon — Optional		

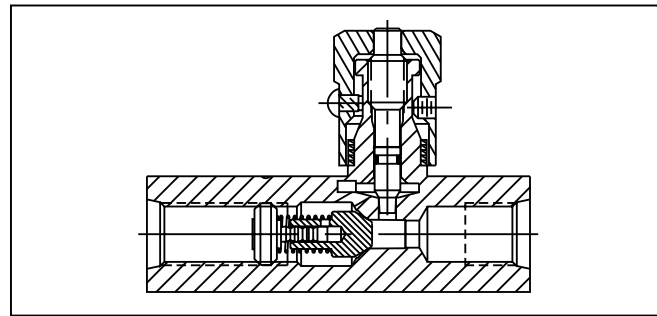
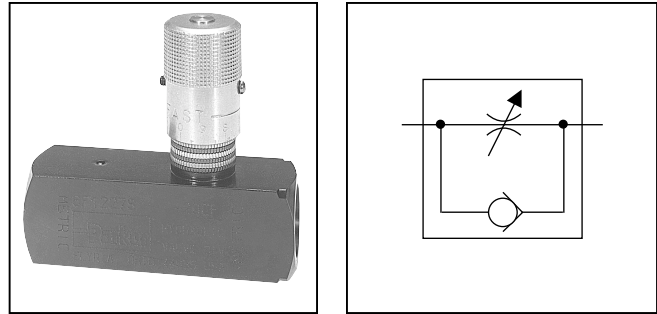

Performance Curves

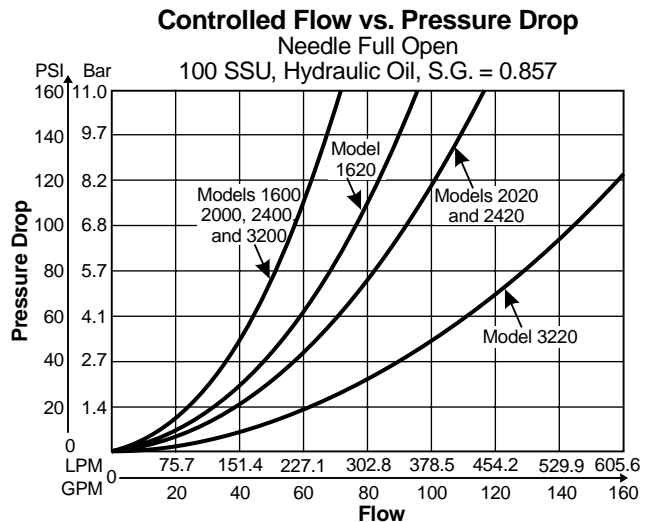
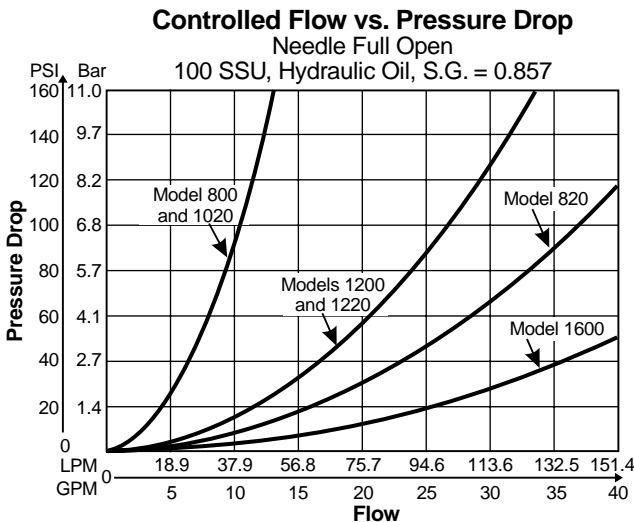
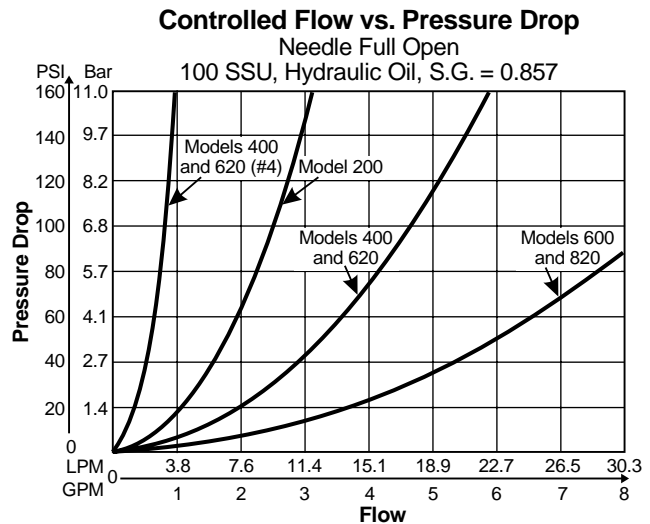

Dimensions

*Inch equivalents for millimeter dimensions are shown in (**)

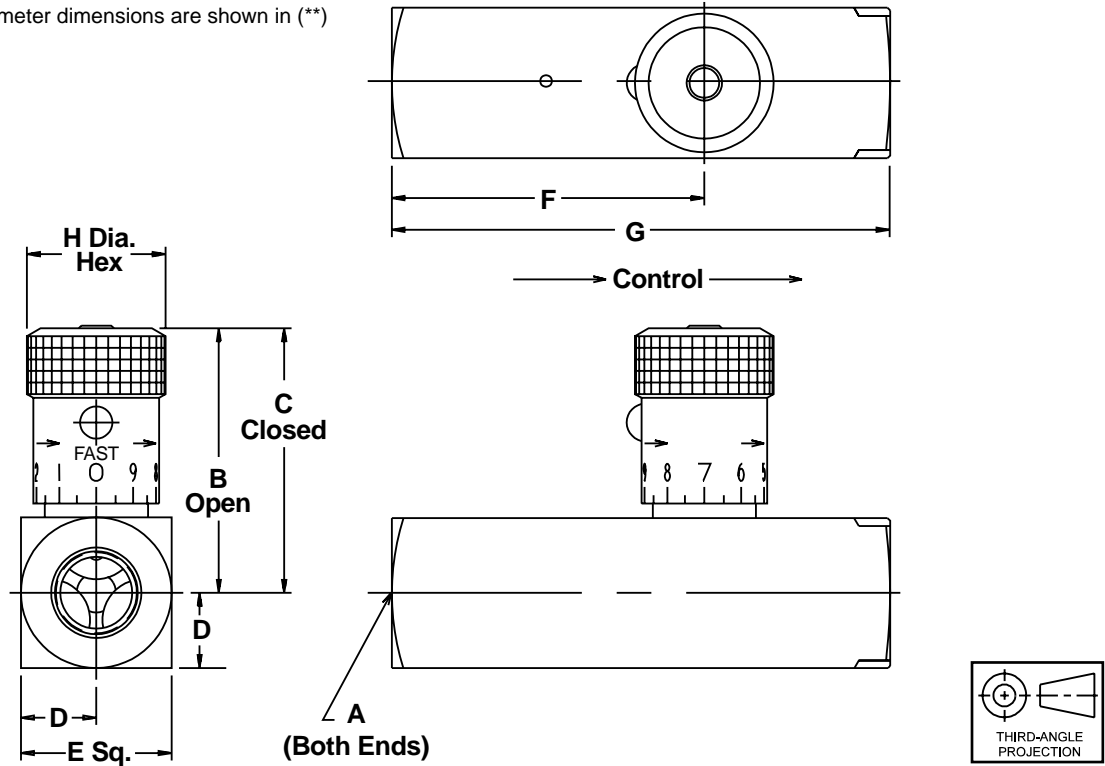

Model Number	A	B	C	D	E	F	G	H
6F616	M16 x 1.5	47.8 (1.88)	42.7 (1.68)	12.7 (0.50)	25.4 (1.00)	48.7 (1.92)	79.2 (3.12)	20.6 (∅ 0.81)
6F818	M18 x 1.5	56.9 (2.24)	51.1 (2.01)	14.2 (0.56)	28.4 (1.12)	53.8 (2.12)	88.9 (3.50)	25.4 (∅1.00)
6F1022	M22 x 1.5	68.6 (2.70)	61.5 (2.42)	15.7 (0.62)	31.8 (1.25)	65.0 (2.56)	101.6 (4.00)	30.2 (∅ 1.19)
6F1227	M27 x 2.0	85.9 (3.38)	71.4 (2.81)	19.1 (0.75)	38.1 (1.50)	76.5 (3.01)	117.3 (4.62)	35.1 (∅1.38)
6F1633	M33 x 2.0	124.7 (4.91)	108.0 (4.25)	22.4 (0.88)	44.5 (1.75)	81.8 (3.22)	127.0 (5.00)	47.8 (*1.88)
6F2042	M42 x 2.0	133.9 (5.27)	117.1 (4.61)	28.7 (1.13)	57.2 (2.25)	98.6 (3.88)	132.8 (5.23)	47.8 (*1.88)
6F2448	M48 x 2.0	140.5 (5.53)	123.7 (4.87)	35.1 (1.38)	69.9 (2.75)	113.5 (4.47)	143.0 (5.63)	47.8 (*1.88)

* = Hex

Ordering Information

6	F	Size	S	[]
Ports	Style	Size	Material	Design Series
Not required for ordering	Not required for ordering	Not required for ordering	Not required for ordering	Not required for ordering

Code	Description
6	ISO 6149 ports

Code	Description
F	Flow Control Valve

Code	Description
616	M16 x 1.5
818	M18 x 1.5
1022	M22 x 1.5
1227	M27 x 2.0
1633	M33 x 2.0
2042	M42 x 2.0
2448	M48 x 2.0

Code	Description
S	Steel

Model Number	Weight Kg (lbs.)
6F616	0.3 (0.6)
6F818	0.5 (1.0)
6F1022	0.8 (1.8)
6F1227	1.2 (2.6)
6F1633	2.3 (5.1)
6F2042	3.7 (8.1)
6F2448	4.6 (10.2)