

QR90K1-TFD

HCFC, R-22, 50 Hz, 3 - Phase, 380/420 V
Air Conditioning



Production Status: Restricted sale - Contact your Copeland Representative.

Performance

<u>Evap(°F)/Cond(°F)</u>	<u>45/130</u>	<u>45/100</u>
<u>RG(°F)/Liq(°F)</u>	<u>65/115</u>	<u>65/85</u>
Capacity (Btu/hr):	74100	99600
Power (Watts):	7600	6350
Current (Amps):	13.3	11.6
EER (Btu/Wh):	9.8	15.6
Mass Flow (lbs/hr):	1090	1280

Mechanical

Overall Length (in):	14.25	Mounting Length (in):	8.66
Overall Width (in):	13.25	Mounting Width (in):	8.66
Overall Height (in):	18.44	Mounting Height (in):	18.63
Suction Size (in):	1 1/8 Stub		
Discharge Size (in):	3/4 Stub		
Initial Oil Charge (oz):	110		
Oil Recharge (oz):	106		
Net Weight (lbs):	175		

Electrical

RLA:	15.8	UL File No.:	SA-2337	MCC (Amps):	22.1
LRA-Low:		UL File Date:	08-Feb-1984	RPM:	
LRA-High:	91.1			CSA File No.:	LR3104C
LRA-Half Winding:					

Alternate Applications

<u>Refrigerant</u>	<u>Frequency (Hz)</u>	<u>Phase</u>	<u>Voltage</u>	<u>Application</u>
R-22 HCFC	60	3	380/460	Air Conditioning

MODEL NUMBER
QR11M1-TFC, D, E
QR12M1-TFC, D, E
QR12ME-TFD
QR15M1-TFC, D, E
QR85K1-TFC, D, E
QR90K1-TFC, D, E

SPECIFICATIONS	
ES NO.	DESCRIPTION

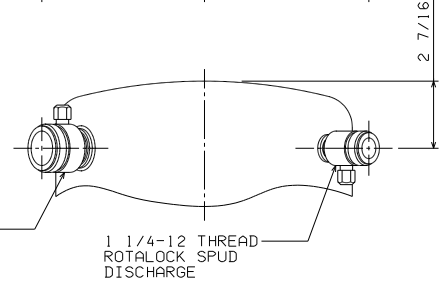
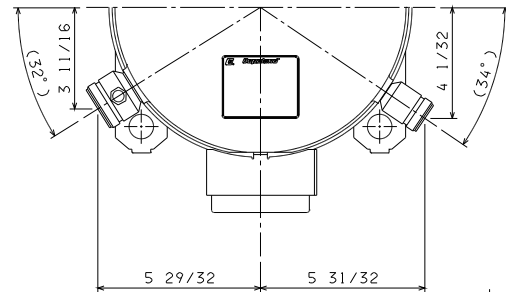
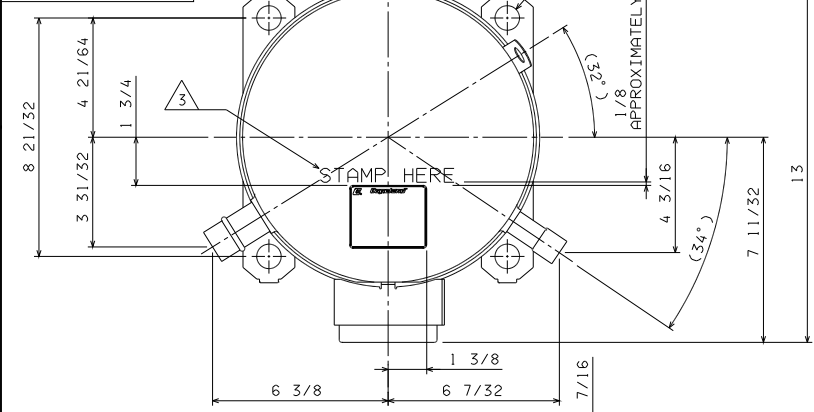

AVAILABLE OPTIONAL FITTINGS

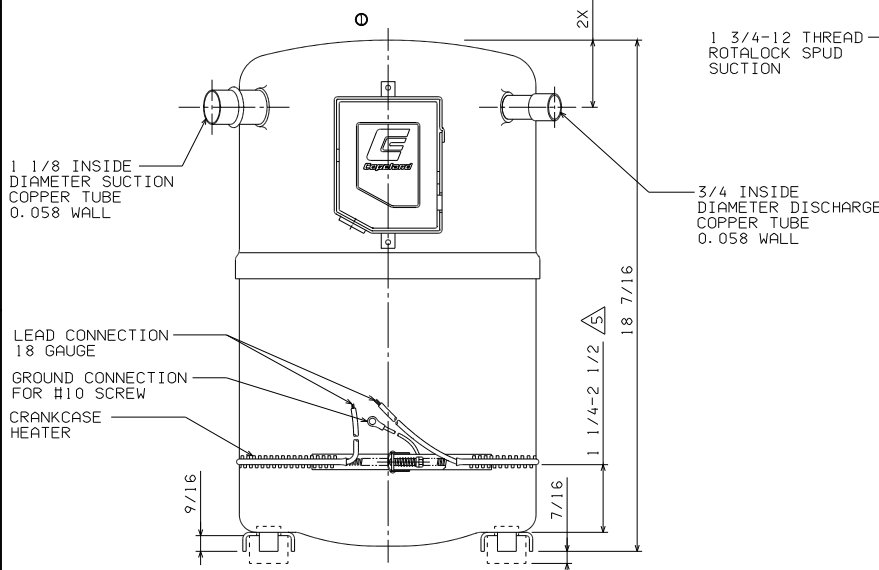

DUE TO ACCUMULATED ASSEMBLY TOLERANCES THE LISTED COMPONENTS MAY VARY FROM THE MOUNTING HOLES AS TABULATED.	
DISCHARGE TUBE	± 0.125
SUCTION TUBE	± 0.188

- NOTES:
- TOLERANCES TO BE ±0.062 UNLESS OTHERWISE SPECIFIED.
 - TUBE ENDS MUST BE PLUGGED.
 - STAMP CUSTOMER PART NUMBER WITH H359 OPAQUE SILVER INK (COPELAND PART HE16104) AS REQUIRED PER B/M. LETTERS TO BE 3/8 HIGH.
 - CRANKCASE HEATER TO BE ENERGIZED FOR A MINIMUM OF FOUR (4) HOURS PRIOR TO COMPRESSOR START UP TO PREVENT HYDRAULIC OIL SLUGGING.
 - CRANKCASE HEATER TO BE LOCATED WITHIN THESE DIMENSIONS.

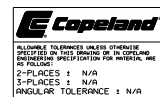

NOTICE
THIS DRAWING AND THE INFORMATION CONTAINED HEREIN ARE THE EXCLUSIVE PROPERTY OF COPELAND. IT SHALL BE RETURNED TO COPELAND UPON DEMAND AND SHALL NOT BE REPRODUCED IN WHOLE OR IN PART, DISCLOSED TO ANYONE ELSE OR USED WITHOUT THE WRITTEN CONSENT OF COPELAND.

32-0202-004	1	TERMINAL BOX PICTORIALY UPDATED	5-4-92	WF	WF
32-0397-016		RELEASE	5-30-97	WF	
CHANGE NOTICE NO.	REV. NO.	REVISIONS	DATE	BY	CHK'D
MATERIAL SPECIFICATIONS	DRAWN BY	CHECKED BY	APPROVED BY	SCALE	SUPERSEDES DWG. NO.
N/A	WFF	WF	DATE	HALF	
2-PLACES : N/A	3-PLACES : N/A	ANGULAR TOLERANCE : N/A	DATE	DO NOT SCALE THIS DRAWING	DATED
TITLE				DRAWING NUMBER	
REF DWG - WELD COMP ASSM				497-2670-00	
					DWG 4
					SHEET 4