



KCE-F Silver Series

CEILING MOUNT TYPE



CEILING MOUNT TYPE – KCE-F Silver Series

Features

- A. Round spigot opening for easy connection to flexible hose.
- B. Non return flap to prevent back-flow.
- C. Body made of high impact ABS plastic.
- D. Balanced turbine with new wide angle, curved blade for quiet operation and high air volume.
- E. High static pressure design for ducted air handling.
- F. Capacitor operated motor with thermal switch.
- G. Spring clip on front cover easily removable for cleaning.
- H. Modern discreet designed cover in silver.

Optional: KCE-F White Series

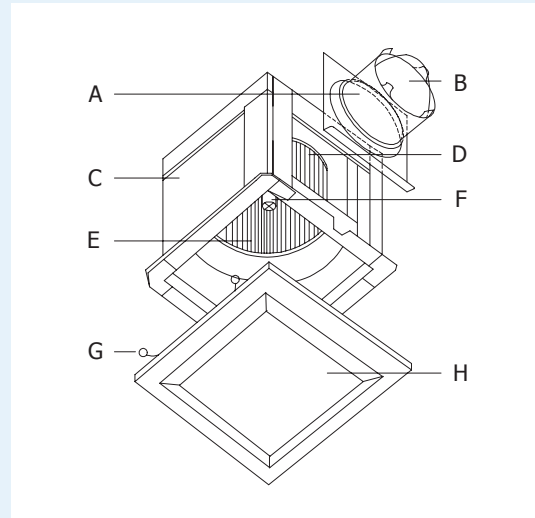

Performance

KCE 110X-F Silver

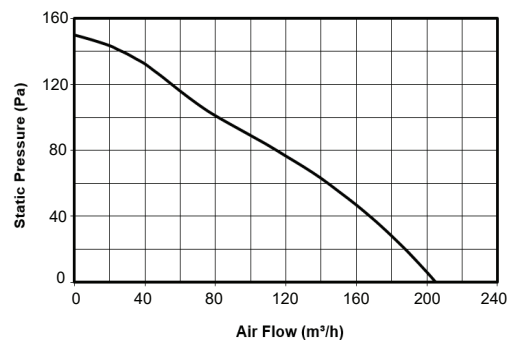
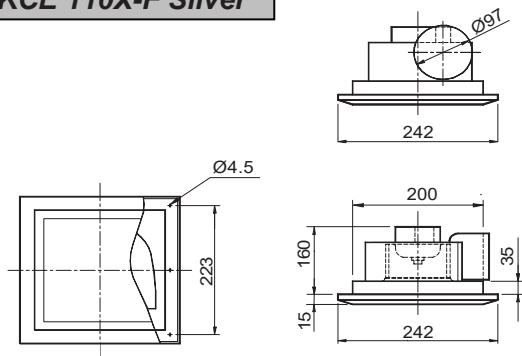

KCE 150X-F Silver

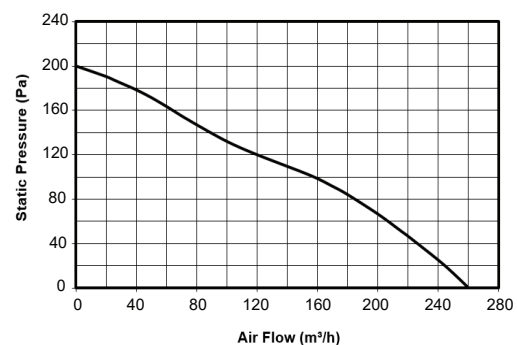
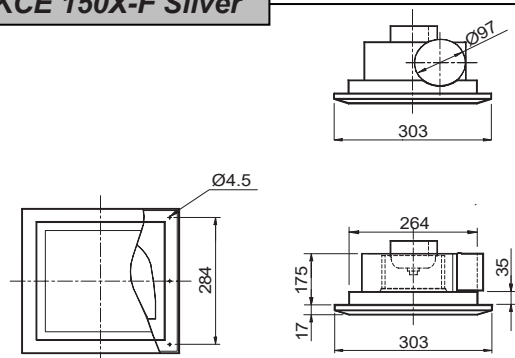

Technical Data

| Model | Max. Flow m³/h | Max. Press. Pa | N° Poles | Power W | Hz | dB | RPM | Weight kg |
|-------------------|----------------|----------------|----------|---------|----|----|------|-----------|
| KCE 110X-F Silver | 205 | 150 | 4 | 30 | 50 | 42 | 1250 | 1.3 |
| KCE 150X-F Silver | 260 | 200 | 4 | 30 | 50 | 43 | 1250 | 1.7 |

The company is always improving and developing its products, therefore the company reserves the right of making changes to the illustrated products. Certified dimension can be provided upon request.