

# Installation Guide

## Thermostatic expansion valves

### Type TGE 10, TGE 20, TGE 40

067R9603

067R9603

067R9603

067R9603

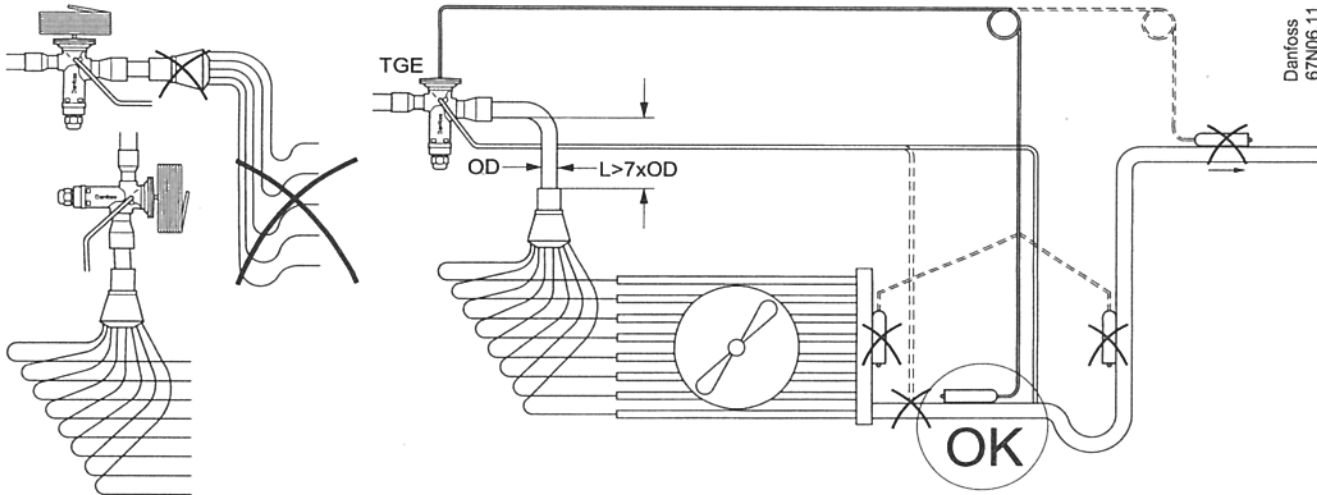

Danfoss  
67N06.11

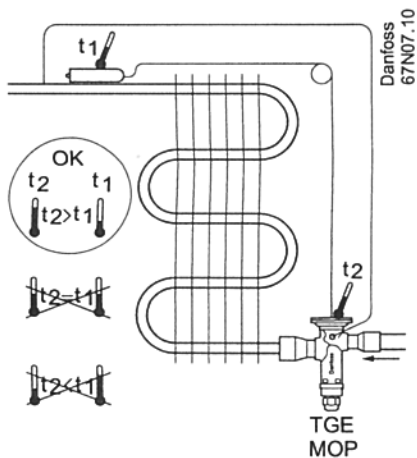

Danfoss  
67N07.10

TGE  
MOP

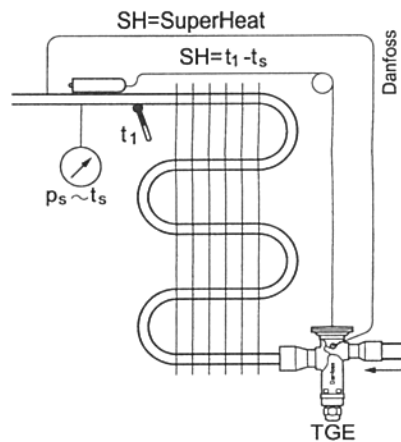

Danfoss  
67N18.11

TGE

Static superheat (SS) adjustment

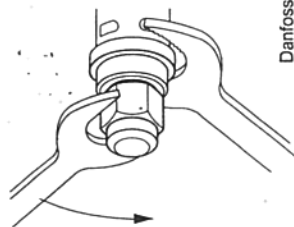

Danfoss  
67N25.10

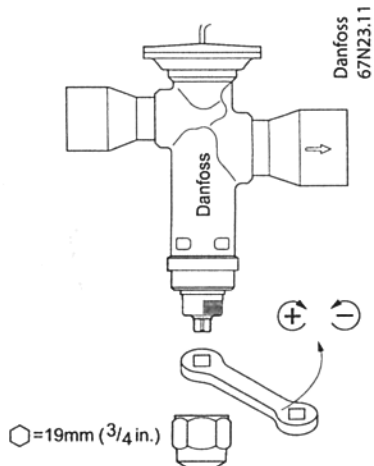

Danfoss  
67N23.11

⌀=19mm (3/4 in.)

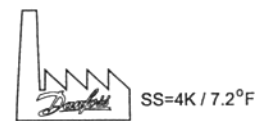

SS=4K / 7.2°F

T= 10 Nm (7ft-lbf)

- TGE 10:  $\Delta SH/360^\circ C \approx 1^\circ C$
- TGE 20:  $\Delta SH/360^\circ C \approx 1.5^\circ C$
- TGE 40:  $\Delta SH/360^\circ C \approx 1.5^\circ C$

Danfoss  
67N26.10