

→ EX-STOCK

技术参数 Specification

型号 Model	额定电压 Rated voltage (v)	频率 Frequency (Hz)	电流 Current (A)	输入功率 Input power (w)	额定转速 Rated speed (r/min)	最大风量 volume (m <sup>3</sup> /h)	最高许用静压 Pressure (pa)	噪声 Noise db(A)	电容 Capacitor μF
YWF2D-200	380	50	0.25	75	2600	1080	120	57	--
YWF2E-200	220	50	0.30	65	2600	1050	118	56	2.5
YWF4E-200	220	50	0.26	53	1480	650	50	50	2.5
YWF2D-250	380	50	0.31	120	2520	1850	190	65	--
YWF2E-250	220	50	0.60	130	2600	1800	188	65	4
YWF4D-250	380	50	0.23	55	1450	1250	60	55	--
→ YWF4E-250	220	50	0.30	60	1420	1230	60	55	2.5
YWF2D-300	380	50	0.28	145	2480	3250	200	66	--
YWF2E-300	220	50	0.85	186	2600	3300	205	66	6
YWF4D-300	380	50	0.28	80	1400	1950	70	60	--
→ YWF4E-300	220	50	0.35	75	1400	1950	70	60	3
YWF2D-350	380	50	0.72	400	2400	4850	225	73	--
YWF2E-350	220	50	1.80	400	2300	4750	223	72	10
YWF4D-350	380	50	0.36	110	1400	3270	93	64	--
→ YWF4E-350	220	50	0.55	110	1400	3270	93	64	4
YWF2D-400	380	50	0.88	530	2380	6480	240	75	--
YWF4D-400	380	50	0.60	185	1400	4800	125	68	--
→ YWF4E-400	220	50	0.86	190	1400	4800	125	68	6
YWF4D-450	380	50	0.50	220	1390	5410	155	70	--
→ YWF4E-450	220	50	1.20	250	1380	5380	150	69	8
YWF6D-450	380	50	0.42	150	950	4650	100	60	--
YWF6E-450	220	50	0.85	160	950	4650	100	60	8
→ YWF4D-500	380	50	0.60	260	1390	8850	190	72	--
YWF4E-500	220	50	1.42	350	1390	8850	190	72	12
YWF6D-500	380	50	0.40	190	950	5800	125	65	--
YWF6E-500	220	50	0.90	210	950	5800	125	65	8
→ YWF4D-550	380	50	0.90	350	1350	10800	215	74	--
YWF4E-550	220	50	2.20	400	1350	10800	215	74	12
YWF6D-550	380	50	0.65	220	950	6500	135	68	--
YWF6E-550	220	50	1.10	280	950	6500	135	68	8
→ YWF4D-600	380	50	1.30	680	1380	13000	230	75	--
YWF4E-600	220	50	3.25	750	1380	13000	230	75	15
YWF6D-600	380	50	1.20	360	930	9600	150	70	--
YWF6E-600	220	50	1.40	450	900	9500	150	70	10
YWF6D-630	380	50	1.30	400	925	9900	160	72	--

表中参数如有更改恕不另行通知 We will not inform you if we change the data in the form

# YWF series

## YWF系列外转子轴流风机

### 一、概述

YWF系列外转子轴流风机是一种新型的高效节能风机，与普通轴流风机相比，该风机具有效率高，噪音低，振动小，结构紧凑，外形美观等特点。因为叶轮直接固定在外圆上，所以轴向尺寸更短，其研制成功是轴流风机的重大突破，达到了国际先进水平。

YWF系列外转子轴流风机因其高效、节能等特点广泛应用于厂矿车间、厨卫、仓库等油、烟尘较严重的场所。

YWF系列外转子轴流风机包括九种类型——罩式、高筒式、矮筒式、方形、岗位式、固定式、台地式、手提式、工频式。

### 二、型号说明

YWF ① 4 ② E ③ - 400 ④ S ⑤

- ① 风机类型: YWF---外转子轴流风机
- ② 电机极数: 2---2极 4---4极 6---6极
- ③ 电机电压: E---单相 D---三相
- ④ 风叶直径: 400---风叶直径为400mm
- ⑤ 风向: S---吸风 B---吹风

### 三、使用环境

1. 此类风机的使用环境温度为一40℃ -- 60℃；
2. 相对湿度不大于90%；
3. 海拔高度不超过1000米。

## YWF Series External Rotor Axial Fan

### 1. Outline

YWF series external rotor axial fan is a new energy efficient fan. Compared with the common fan, this external rotor fan has the advantage of high efficiency, low noise, low vibration, compact structure and beautiful appearance. The impeller is fixed in the motor directly, so the axial dimension becomes shorter. It is a great breakthrough for axial fan and it also reached a high level in the world.

YWF series external rotor axial fan is used more widely than the common fan in kitchen & bath, mining and other place where with much oil, smoke and dust.

YWF series external rotor axial fan including 9 species --- mesh enclosure type, long tube type, short tube type, square type, standing type, fixed type, floor type, portable type and industrial frequency type.

### 2. Model Description

YWF ① 4 ② E ③ - 400 ④ S ⑤

- ① Fan Type: YWF --- External Rotor Axial Fan
- ② Motor Pole: 2---2 pole 4---4 pole 6---6 pole
- ③ Motor Voltage: E---Single phase D---Three phase
- ④ Diameter of Impeller: 400---The Diameter of impeller is 400mm
- ⑤ Wind direction: S---Suction B---Blow

### 3. Using Ambient

- (1). Using ambient temperature is -40℃ to 60℃
- (2). Relative humidity less than 90%
- (3). The elevation is less than or equal to 1000m

YWF 200-630 SERIES EXTERNAL ROTOR AXIAL FAN

列外转子轴流风机

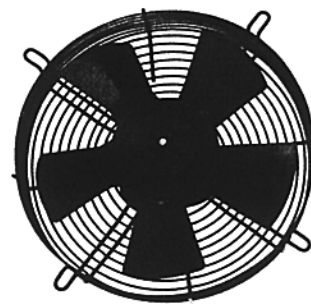
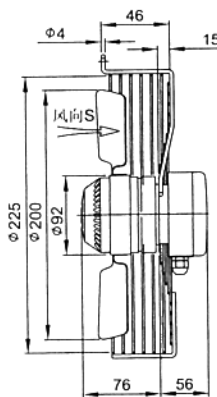
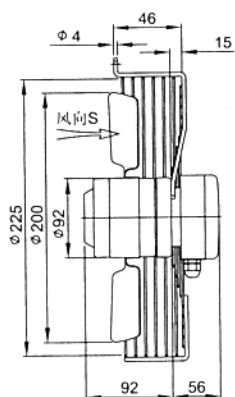
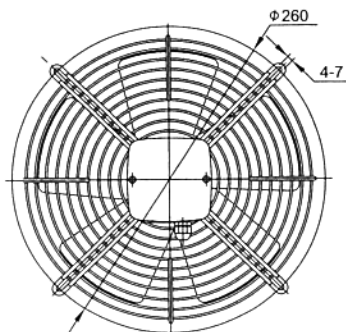

YWF 200

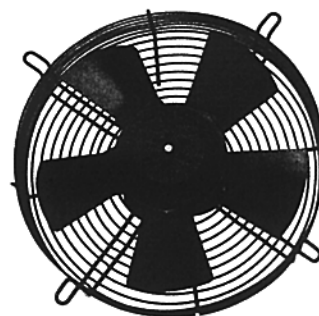
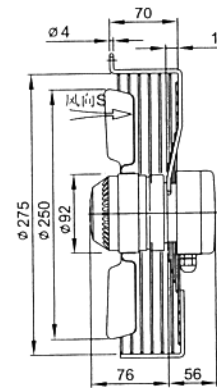
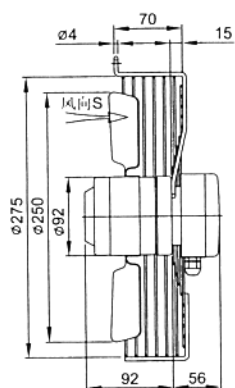
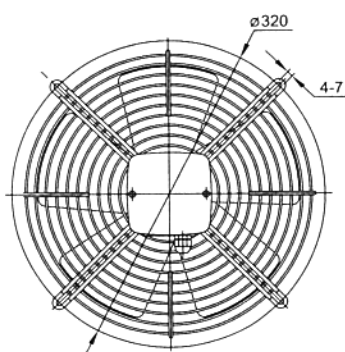

YWF 250

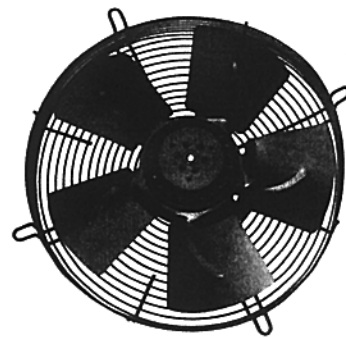
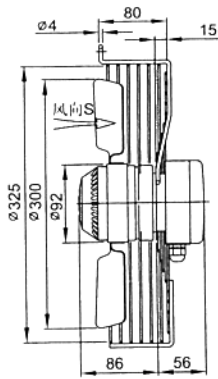
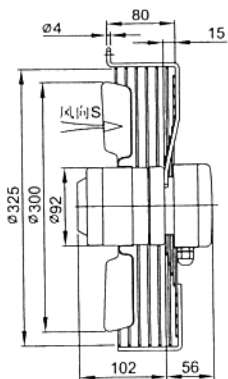
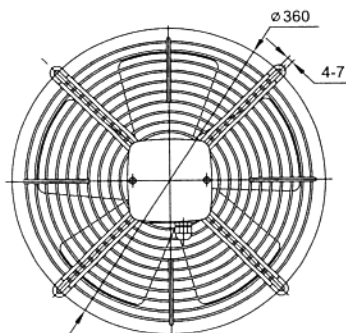

YWF 300

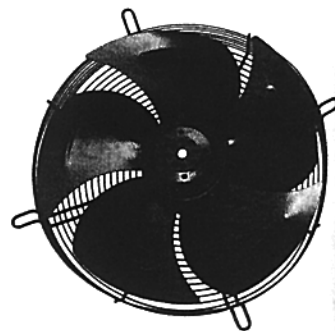
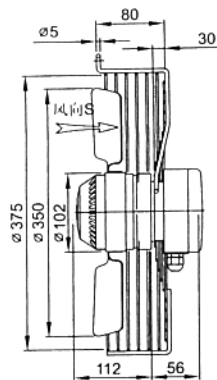
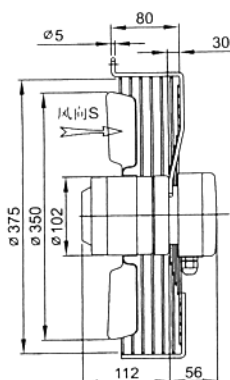
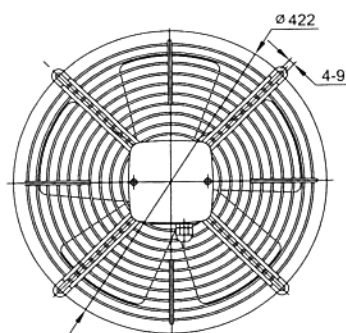

YWF 350

# YWF 200-630 SERIES EXTERNAL ROTOR AXIAL FAN

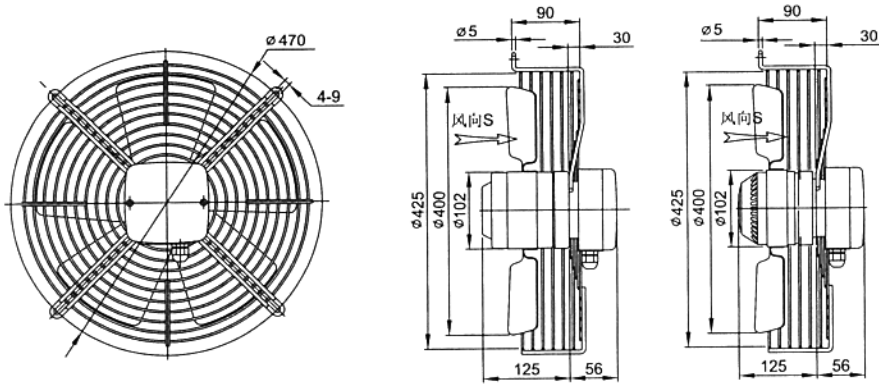

**YWF 400**

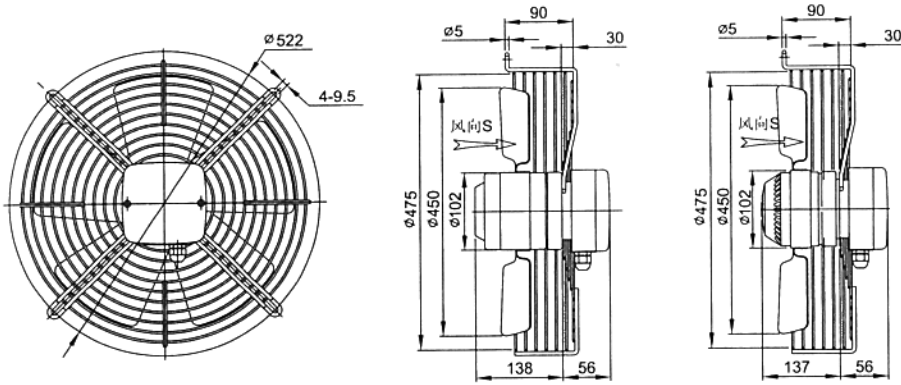

**YWF 450**

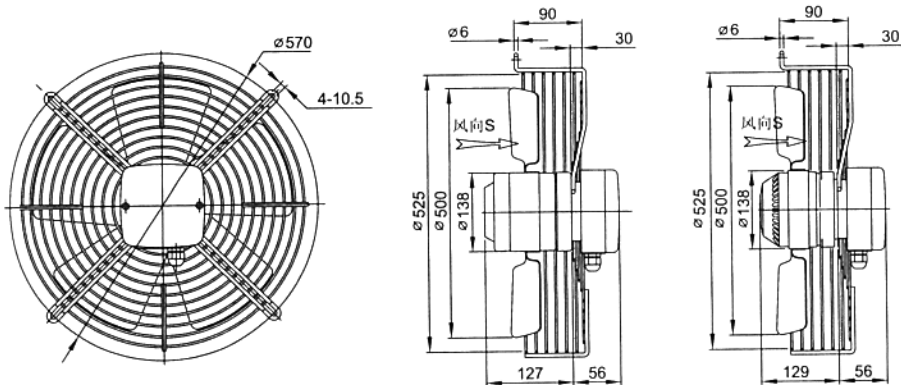

**YWF 500**

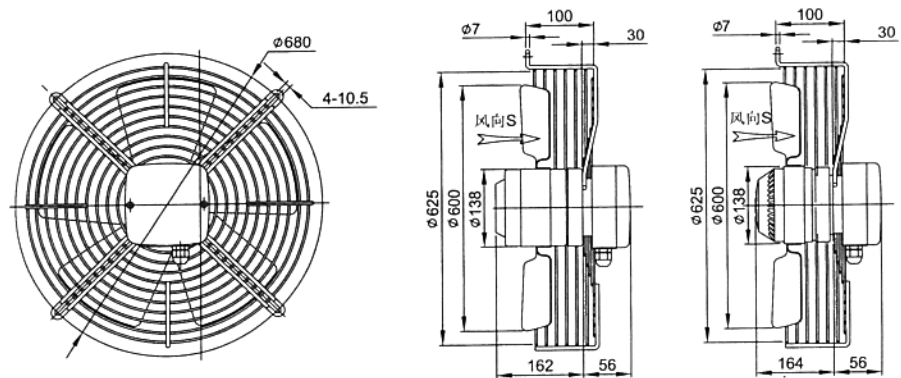

**YWF 550**