



Series
MS

Magnesense® Differential Pressure Transmitter

Monitors Pressure & Air Velocity



Standard MS with optional LCD

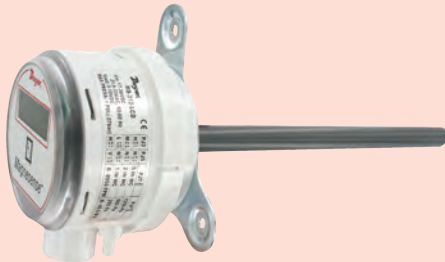

MS with optional LCD and static probe

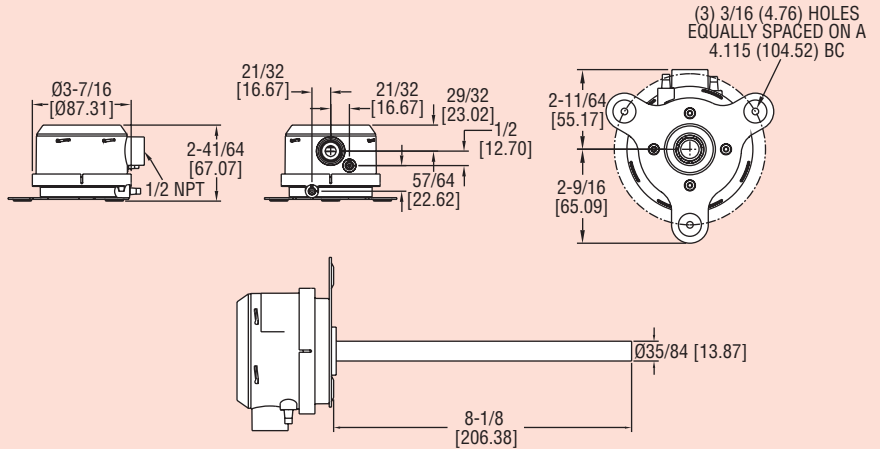

The Series MS Magnesense® Differential Pressure Transmitter is an extremely versatile transmitter for monitoring pressure and air velocity. This compact package is loaded with features such as:

- Field selectable English or Metric ranges
- Field upgradeable LCD display
- Adjustable damping of output signal (with optional display)
- Ability to select a square root output for use with pitot tubes and other similar flow sensors

Along with these features, the patented magnetic sensing technology provides exceptional long term performance and enables the Magnesense® Differential Pressure Transmitter to be the single solution for your pressure and flow applications.

Model	Output	Selectable Ranges
MS-121*	4-20 mA	0.1", 0.25", 0.5" w.c. (25, 50, 100 Pa)
MS-321*	0-10 V	0.1", 0.25", 0.5" w.c. (25, 50, 100 Pa)
MS-721*	0-5 V	0.1", 0.25", 0.5" w.c. (25, 50, 100 Pa)
MS-111*	4-20 mA	1", 2", 5" w.c. (250, 500, 1250 Pa)
MS-311*	0-10 V	1", 2", 5" w.c. (250, 500, 1250 Pa)
MS-711*	0-5 V	1", 2", 5" w.c. (250, 500, 1250 Pa)
MS-131	4-20 mA	10" w.c. (2 kPa)
MS-141	4-20 mA	15" w.c. (3 kPa)
MS-151	4-20 mA	25" w.c. (5 kPa)
MS-331	0-10 V	10" w.c. (2 kPa)
MS-341	0-10 V	15" w.c. (3 kPa)
MS-351	0-10 V	25" w.c. (5 kPa)
MS-021	4-20 mA	±0.1", 0.25", 0.5" w.c. (±25, 50, 100 Pa)
MS-221	0-10 V	±0.1", 0.25", 0.5" w.c. (±25, 50, 100 Pa)
MS-621	0-5 V	±0.1", 0.25", 0.5" w.c. (±25, 50, 100 Pa)

OPTIONS

Note: Add -LCD to end of model for units with display.

*Models available with duct mount static pressure probe. Change last digit from 1 to 2. Ex. MS-122

Add suffix -NIST to end of model numbers for NIST traceable calibration certificate. Example: MS-021-NIST.

Add suffix -FC to end of model numbers for factory calibration certificate. Example: MS-021-FC.

SPECIFICATIONS

Service: Air and non-combustible, compatible gases.

Wetted Materials: Consult factory.

Accuracy: ±1% for 0.25" (50 Pa), 0.5" (100 Pa), 2" (500 Pa), 5" (1250 Pa), 10" (2 kPa), 15" (3 kPa), 25" (5 kPa) ±2% for 0.1" (25 Pa), 1" (250 Pa) and all bi-directional ranges.

Stability: ±1% / year FSO.

Temperature Limits: 0 to 150°F (-18 to 66°C).

Pressure Limits: 1 psi maximum, operation; 10 psi, burst.

Power Requirements: 10 to 35 VDC (2-wire); 17 to 36 VDC or isolated 21.6 to 33 VAC (3-wire).

Output Signals: 4 to 20 mA (2-wire); 0 to 5 V, 0 to 10 V (3-wire).

Response Time: Adjustable 0.5 to 15 sec. time constant. Provides a 95% response time of 1.5 to 45 seconds.

Zero & Span Adjustments: Digital push button.

Loop Resistance: Current output: 0-1250 Ω max; Voltage output: min. load resistance 1 kΩ.

Current Consumption: 40 mA max.

Display (optional): 4 digit LCD.

Electrical Connections:

4-20 mA, 2-Wire: European style terminal block for 16 to 26 AWG.

0-10 V, 3-Wire: European style terminal block for 16 to 22 AWG.

Electrical Entry: 1/2" NPS thread.

Accessory (A-151): Cable gland for 5 to 10 mm diameter cable.

Process Connections: 3/16" ID tubing (5 mm ID). Maximum OD 9 mm.

Enclosure Rating: NEMA 4X (IP66).

Mounting Orientation: Diaphragm in vertical position.

Weight: 8.0 oz (230 g).

Agency Approvals: CE.

ACCESSORIES

A-435, Field Upgradeable LCD

A-480, Plastic Static Pressure Tip

A-481, Installer kit. Includes 2 plastic static pressure tips and 7 ft (2.1 m) of PVC tubing

A-489, 4" Straight Static Pressure Tip with Flange

A-302F-A, 303 SS Static Pressure Tip with mounting flange. For 3/16" ID rubber or plastic tubing. 4" insertion depth. Includes mounting screws

SCD-PS, 100 to 240 VAC/VDC to 24 VDC Power Supply

See page 587 for process tubing options.

One Unit for all your Building Pressure Applications

The Industry Standard for Building Automation

- **Field Selectable Ranges** in metric or English. Lowers stock and inventory requirements. You'll always have the right transmitter for every job.

- **Field Upgradable LCD.** No need to order two separate transmitters. Simply stock a transmitter and display and you can satisfy any customer's requests. Simply remove cover and snap the LCD onto the board.

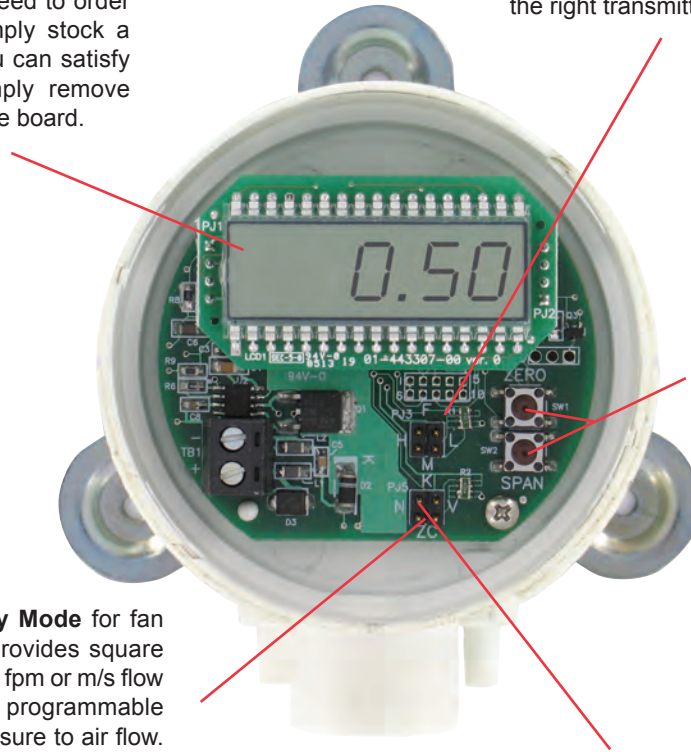

- **Digital Push Button Zero and Span.** Reduces calibration time significantly over other transmitters that utilize potentiometers. Lowers maintenance time and costs.

- **Field Selectable Air Velocity Mode** for fan and blower applications. Unit provides square root output that accurately tracks fpm or m/s flow rate. No need for a smart programmable indicator or PLC to convert pressure to air flow. Reduces components and installation time lowering overall costs.

- **Adjustable Digital Damping** smooths out unstable pressure fluctuations common in air flow applications.

