



TORQUE WRENCH

TA771 Series

INSTRUCTION MANUAL



Thank you for purchasing the TA771 Series Torque Wrench. Please read this instruction manual carefully before use so that you can use the product properly.

 **TASCO JAPAN CO., LTD.**

⚠ Warning

1. Do not use the torque wrench to loosen screws.

Loosening screws puts excessive torque on and thus causes damage to the torque wrench, which could lead to an accident or injury.

2. Make sure that there is no oil or grease adhering to the grip.

A slippery grip could cause an accident or injury.

3. Check if there is no crack, blem, or rust.

They cause damage to the torque wrench, which could lead to an accident or injury. Have it inspected or repaired.

4. When working at a high place, take preventive measures against falling.

Dropping the torque wrench or socket could cause a serious accident or injury.

5. Do not use a pipe to extend the grip.

This could cause break the torque wrench or affect its precision.

⚠ Caution

1. When jacking it up, do not kick-start, put your weight on, or tramp on the torque wrench.

Breakage or slips when tightening the screw could cause an accident or injury.

2. Do not use the torque wrench beyond its maximum torque.

Breakage could cause an accident or injury

3. Do not use a torque wrench which has a missing part, ie which lacks the pin, dial or so.

4. Do not alter the torque wrench.

Altering the torque wrench undermines its strength and precision, which could cause an accident or injury.

5. Do not drop or shock the torque wrench.

Dropping or shocking the torque wrench damages or deforms it to undermine its precision and durability, which could cause an accident or injury.

[About the Torque Wrench]

In order to prevent the leak of the refrigerant by the weak tightening of the flare nut or to prevent the damage of the copper tube flare section by tightening too much, bind the flare nut with a proper bolting torque. If a torque wrench is attached with a regular bolting torque, the head will eventually break.

[Operating Instructions]

1. Do not mix up the torque units (kgf_cm, kgf_m, N_m, etc.).

Check the torque unit before use.

2. Do not use the torque wrench in water or under the sea.

Its internal structure deteriorates to cause an accident or injury. When having dropped the torque wrench into water or the sea, have it inspected or repaired.

3. Seize the grip firmly to exert torque.

The right torque value cannot be achieved without seizing the grip.

4. Stop tightening when hearing the grip click.

Further tightening results in excessive torque.

5. When moving the torque wrench, be careful not to hit the surrounding things by the hand or elbow.

When using the torque wrench, be careful not to hit the surrounding things by the hand or elbow.

6. Do not substitute the torque wrench as a hammer or lever.

A deformed head or tube causes malfunction and affects precision.

7. Have it inspected regularly.

The torque wrench requires regular inspection.

8. Keep in mind the direction of force (Figure 1).

The direction of force must be perpendicular to the torque wrench (permissible $\pm 15^\circ$ and within $\pm 15^\circ$ from side to side and up and down).

9. Before storage after use, remove dirt, dust, mud, oil, moisture, etc.

Storing the torque wrench with dirt on it could affect its function and precision.

(Figure1)

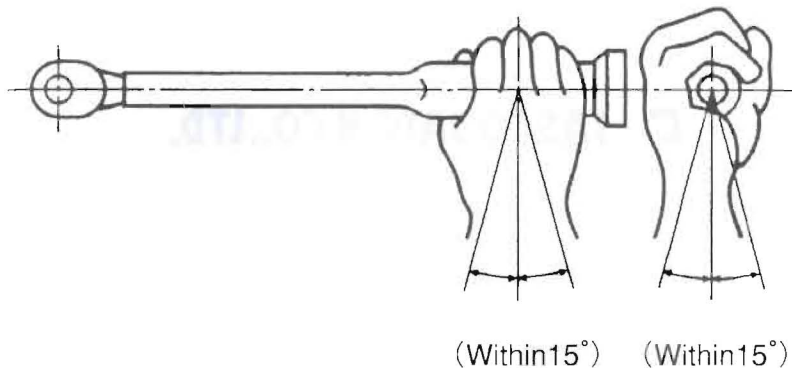



 **TASCO JAPAN CO., LTD.**

Head Office 1-2-16, Kawaguchi, Nishi-ku, Osaka
Phone +81-6-6584-0809 Fax +81-6-6584-1056
Tokyo Office Tennoz Yusen BLDG. 14F.
2-2-20, Higashishinagawa, Shinagawa-ku, Tokyo
Phone +81-3-5796-0809 Fax +81-3-5796-0888
Warehouse 4-4-55, Higashikonoike-cho, Higashiosaka
Phone +81-72-968-0120 Fax +81-72-968-0150