

# VACUUM PUMP

**Operating Manual**

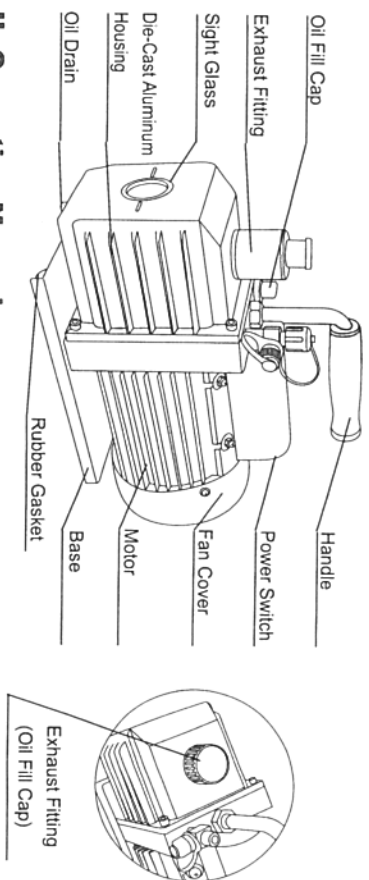

**I. Pump components**



**II. Operating Manual**

**1. Before using your vacuum pump**

In all cases, motors are designed for operating voltages plus or minus 10% of the normal rating. Single voltage motors are supplied fully connected and ready to operate.

(1) Check to be sure the voltage and frequency at the outlet match the specifications on the pump motor decal. Check the ON-OFF switch to be sure it is in the OFF position before you plug the pump into an outlet. Remove and discard the exhaust plug from the end of the pump's handle.

(2) The pump is shipped without oil in the reservoir. Before starting the pump, fill it with oil. Remove the OIL FILL cap and add oil until oil just shows in the bottom of the sight glass. The approximate oil capacity of the pump is 220~380ml (reference the technical data).

(3) Replace the OIL FILL cap and remove the cap from one of the inlet ports. Turn the motor switch to ON. When the pump runs smoothly, replace the cap on the inlet port. This may take from two to 30 seconds depending on the ambient temperature. After the pump runs for approximately one minute, check the sight glass for proper oil level should be even with the sight glass OIL LEVEL line. Add oil if necessary.

**Note:** When the pump is running, the oil level should be even with the line on the sight glass. Underfilling will result in poor vacuum performance. Over filling can result in oil blowing from the exhaust.

Please read the operating manual carefully before using and reserve it properly

## VACUUM PUMP

2. To shut down your pump after use

To help prolong pump life and promote easy starting, follow these procedures for shutdown.

- (1) Choose the manifold valve between the pump and the system.
- (2) Remove the hose from the pump inlet.
- (3) Cap the inlet port to prevent any contamination or loose particles from entering the port.

### III. To maintain your high vacuum pump

1. Vacuum pump oil:

The condition and type of oil used in any high vacuum pump are extremely important in determining the ultimate attainable vacuum. We recommends the use of High Vacuum Pump Oil. This oil has been specifically blended to maintain maximum viscosity at normal running temperatures and to improve cold weather starts.

2. Oil Change Procedure

- (1) Be sure the pump is warmed up.
- (2) Remove the OIL DRAIN cap. Drain contaminated oil into a suitable container and dispose of properly. Oil can be forced from the pump by opening the inlet and partially blocking the exhaust with a cloth while the pump is running. Do not operate the pump for more than 20 seconds using this method.
- (3) When the flow of oil has stopped, tilt the pump forward to drain residual oil.
- (4) Replace the OIL DRAIN cap. Remove the OIL FILL cap and fill the reservoir with new vacuum pump oil until the oil just shows at the bottom of the sight glass. The approximate oil capacity of the pump is 220~380ml (reference the technical data).
- (5) Be sure the inlet ports are capped, then turn on the pump. Allow it to run for one minute; then check the oil level. If the oil is below the sight glass OIL LEVEL line, add oil slowly (with the pump running) until the oil reaches the OIL LEVEL line. Replace the OIL FILL cap, making sure the inlet is capped and the drain cap is tight.
- (6) a) If the oil is badly contaminated with sludge that forms when water is allowed to collect in the oil, you may need to remove the oil reservoir cover and wipe it out.

## VACUUM PUMP

b) Another method of dealing with heavily contaminated oil is to force the

oil from the pump reservoir. To do this, allow the pump to run until it is warmed up.

While the pump is still running, remove the oil drain cap. Slightly restrict the exhaust. This will back-pressure the oil reservoir and force the oil from it, carrying more contaminants. When the oil ceases to flow, turn off the pump.

Repeat this procedure as required until the contamination is removed

Replace the OIL DRAIN cap and refill the reservoir to the proper level with fresh pump oil.

### IV. Troubleshooting Guide

Your pump has been designed for dependable use and long life. If something should go wrong, however, the following guide will help you get pump back into service as quickly as possible.

If disassembly of the pump is required, please check your warranty. The warranty may be voided by misuse or customer tampering which results in the pump being inoperable.

1. Failure To Start

Check the line voltage. The pumps are designed to start at  $\pm 10\%$  line voltage (loaded) at 32°F. At extremes, however, switching between the start and run windings may occur.

2. Oil leakage

(1) Be sure the oil is not a residual accumulation from spillage, etc.

(2) If leakage exists, the module cover gasket or the shaft seal may need replacing. If leakage exists in the area of the oil drain plug, you may need to reseal the plug using a commercial pipe thread sealer.

3. Failure To Pull A Good Vacuum

(1) Be sure the vacuum gauge and all connections are in good condition and leak free. You can confirm leakage by monitoring the vacuum with a thermistor gauge while applying vacuum pump oil at connections or suspected leak points. The vacuum will improve briefly while the oil is sealing the leak.

(2) Be sure the pump oil is clean. A badly contaminated pump may require several oil flushes.

(3) Be sure the oil is at the proper level. For maximum pump operation, the oil

## VACUUM PUMP

must be even with the OIL LEVEL line on the sight glass when the pump is running. Do not overfill-----operating temperatures will cause the oil to expand, so it will appear at a higher level than when the pump is not running.To check the oil level, start the pump with the inlet capped.Check the oil level in the sight glass.Add oil if necessary.

### V.Technical Parameter

Single Stage Vacuum Pump							
Model	MV-115	MV-125	MV-135	MV-145	MV-160	MV-180	
Voltage	220V -50Hz	110V -50Hz	220V -50Hz	110V -50Hz	220V -50Hz	110V -50Hz	
Free Air Displacement	CFM	1.5	1.8	2.5	3.0	3.5	4.0
	L/min	42	50	70	84	100	114
Ultimate Vacuum	Pa	5	5	5	5	5	5
	mbar	0.05	0.05	0.05	0.05	0.05	0.05
Motor	1/4	1/4	1/3	1/3	1/2	3/4	
Intake Fitting	1/4"Flare	1/4"Flare	1/4"3/8"Flare	1/4"3/8"Flare	1/4"3/8"Flare	3/8"Flare	
Oil Capacity	310	310	310	300	440	890	
Dimensions(mm)	285X124X230	285X124X230	315X124X240	315X124X240	335X138X250	400X145X270	
Net Weight(kg)	6.3	7.1	8.1	8.2	10.5	15.0	

Dual Stage Vacuum Pump									
Model	MV-215	MV-225	MV-235	MV-245	MV-260	MV-280	MV-2100		
Voltage	220V -50Hz	110V -50Hz	220V -50Hz	110V -50Hz	220V -50Hz	110V -50Hz	220V -50Hz	110V -50Hz	220V -50Hz
Free Air Displacement	CFM	1.5	1.8	2.5	3.0	3.5	4.0	4.5	5.0
	L/min	42	50	70	84	100	114	128	142
Ultimate Vacuum	Pa	3X10 <sup>-1</sup>	3X10 <sup>-1</sup>	3X10 <sup>-1</sup>	3X10 <sup>-1</sup>	3X10 <sup>-1</sup>	3X10 <sup>-1</sup>	3X10 <sup>-1</sup>	3X10 <sup>-1</sup>
	mbar	0.003	0.003	0.003	0.003	0.003	0.003	0.003	0.003
Motor	Microns	25	25	25	25	25	25	25	25
		1/4	1/3	1/3	1/2	3/4	1	1	1
Intake Fitting	1/4"Flare	1/4"Flare	1/4"3/8"Flare	1/4"3/8"Flare	1/4"3/8"Flare	1/4"3/8"Flare	1/4"3/8"Flare	1/4"3/8"Flare	1/4"3/8"Flare
Oil Capacity	200	250	350	330	700	590	590		
Dimensions(mm)	308X124X230	315X124X240	335X138X250	335X138X250	400X145X270	400X145X270	400X145X270		
Net Weight(kg)	7.5	8.6	11.2	11.4	16.5	16.7	16.7		

## VACUUM PUMP

### VI.Exploded Drawing

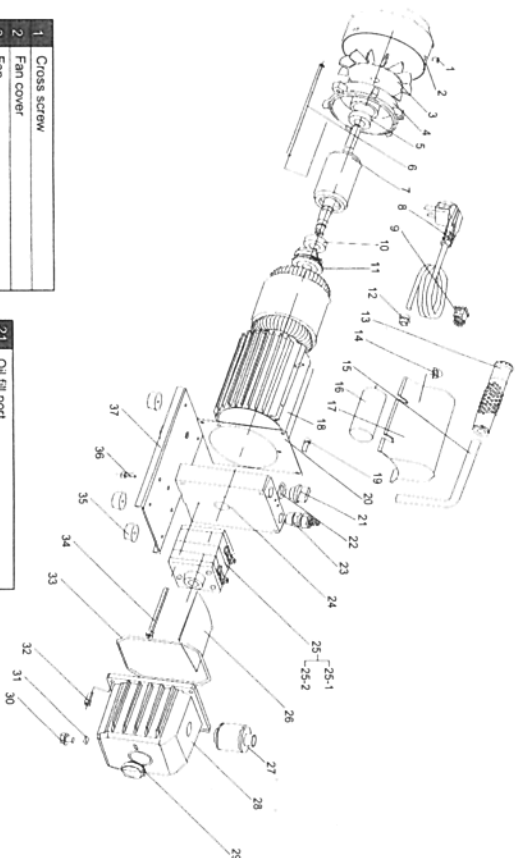

1	Cross screw
2	Fan cover
3	Fan
4	Motor cover
5	Bearing
6	Cross screw
7	Motor rotor
8	Power supply cords
9	Power switch
10	Bearing
11	Centrifugal switch
12	Insulating bushing
13	Handle slipcover
14	Nut
15	Handle
16	Capacitor
17	Junction box
18	Motor hull
19	Screw
20	Trestle cover board
21	Oil fill port
22	Seal
23	Inlet fitting
24	Trestle
25	Pump body
25-1	Rotary-vane
25-2	Rotary-vane spring
26	Cap board
27	Exhaust fitting
28	Die cast aluminum housing
29	Sight glass
30	Oil cap
31	Seal
32	Screw
33	Seal
34	Screw
35	Rubber foot
36	Screw
37	Base