

HSH-D series

Duct Temp. & Relative Humidity Sensors

Honeywell HSH-D series duct temperature & relative humidity sensors are applied to measure the HVAC duct air temperature and relative humidity.

The HSH-D series duct temperature & relative humidity sensors have a variety of control signal outputs and can be compatible with a variety of automatic control systems



Basic Parameters

Measuring Temp. Range	-40 ~ 60 °C	
Working Environment	-40~60°C, 0~95%RH (Non condensation)	
Humidity Accuracy @ 25°C and 24VDC	2%	20~80%: ±2%; 0-95%: ±3%
	3%	20~80%: ±3%; 0-95%: ±5%
	5%	20~80%: ±5%; 0-95%: ±9%
Power Supply	0-10V	24 VDC/24VAC±20%
	4-20mA	24 VDC ±20%
IP Rated	IP65	
Wire conduct Diameter	0.33~1.65mm ²	
Storage Temp.	-40 ~ 70 °C	
Housing Material	PC (Fire rating: UL94-V0)	
Certification	EN IEC 61000-6-3:2021, EN IEC 61000-6-2:2019 EN IEC 60730-1:2016+A1, EN IEC 60730-2-9:2019+A1	

Definition

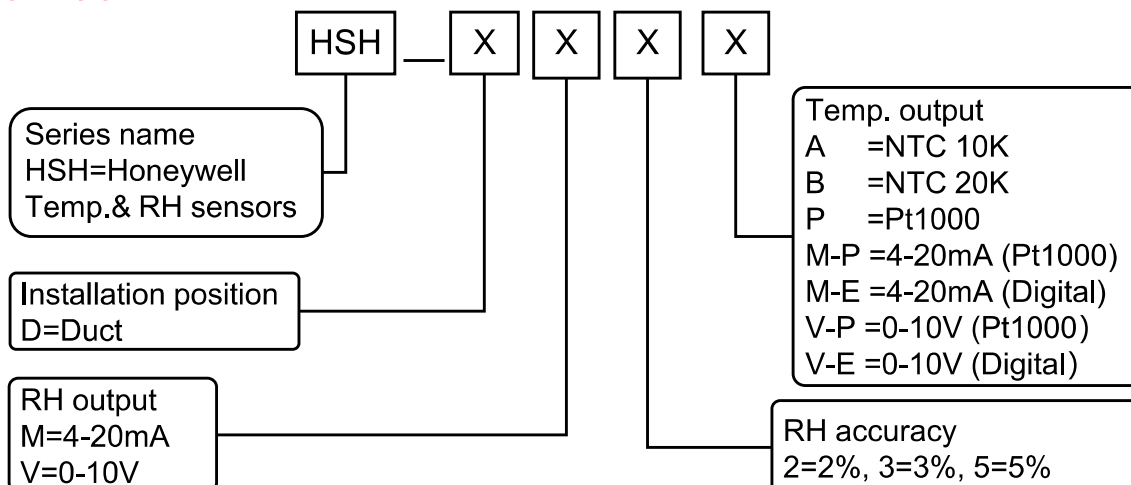

Order information and Technical Specification

SKU	RH Output	RH accuracy	Temp. Output	Temp. sensor element type	Temp. Accuracy*
HSH-DM2A	4~20mA	2%	Resistance Value	10K NTC	0.3K @ 25°C
HSH-DM2B	4~20mA	2%	Resistance Value	20K NTC	0.3K @ 25°C
HSH-DM2P	4~20mA	2%	Resistance Value	PT1000	0.2K @ 0°C
HSH-DM2M-P	4~20mA	2%	4~20mA	PT1000	0.3K @ 25°C
HSH-DM2M-E	4~20mA	2%	4~20mA	Digital**	0.3K @ 25°C
HSH-DM3A	4~20mA	3%	Resistance Value	10K NTC	0.3K @ 25°C
HSH-DM3B	4~20mA	3%	Resistance Value	20K NTC	0.3K @ 25°C
HSH-DM3P	4~20mA	3%	Resistance Value	PT1000	0.2K @ 0°C
HSH-DM3M-P	4~20mA	3%	4~20mA	PT1000	0.3K @ 25°C
HSH-DM3M-E	4~20mA	3%	4~20mA	Digital	0.3K @ 25°C
HSH-DM5A	4~20mA	5%	Resistance Value	10K NTC	0.3K @ 25°C
HSH-DM5B	4~20mA	5%	Resistance Value	20K NTC	0.3K @ 25°C
HSH-DM5P	4~20mA	5%	Resistance Value	PT1000	0.2K @ 0°C
HSH-DM5M-P	4~20mA	5%	4~20mA	PT1000	0.3K @ 25°C
HSH-DM5M-E	4~20mA	5%	4~20mA	Digital	0.3K @ 25°C
HSH-DV2A	0~10V	2%	Resistance Value	10K NTC	0.3K @ 25°C
HSH-DV2B	0~10V	2%	Resistance Value	20K NTC	0.3K @ 25°C
HSH-DV2P	0~10V	2%	Resistance Value	PT1000	0.2K @ 0°C
HSH-DV2V-P	0~10V	2%	0-10V	PT1000	0.3K @ 25°C
HSH-DV2V-E	0~10V	2%	0-10V	Digital	0.3K @ 25°C
HSH-DV3A	0~10V	3%	Resistance Value	10K NTC	0.3K @ 25°C
HSH-DV3B	0~10V	3%	Resistance Value	20K NTC	0.3K @ 25°C
HSH-DV3P	0~10V	3%	Resistance Value	PT1000	0.2K @ 0°C
HSH-DV3V-P	0~10V	3%	0-10V	PT1000	0.3K @ 25°C
HSH-DV3V-E	0~10V	3%	0-10V	Digital	0.3K @ 25°C
HSH-DV5A	0~10V	5%	Resistance Value	10K NTC	0.3K @ 25°C
HSH-DV5B	0~10V	5%	Resistance Value	20K NTC	0.3K @ 25°C
HSH-DV5P	0~10V	5%	Resistance Value	PT1000	0.2K @ 0°C
HSH-DV5V-P	0~10V	5%	0-10V	PT1000	0.3K @ 25°C
HSH-DV5V-E	0~10V	5%	0-10V	Digital	0.3K @ 25°C

* 1. For the passive output type sensors, the temperature accuracy is the sensing element temperature accuracy. For the current and voltage signal output type sensors, the temperature accuracy is the transmitter accuracy when the power supply is 24VDC.

* 2. The temperature accuracy in the table above is the accuracy of the specified temperature point.

** Temperature sensor element type is **Digital** refers to the sensor type is PN junction type digital temperature sensing element, **Digital** is for short.

Temperature range setting and Wiring diagrams

1. Measure Temperature range setting (only for 0-10V and 4-20mA output)

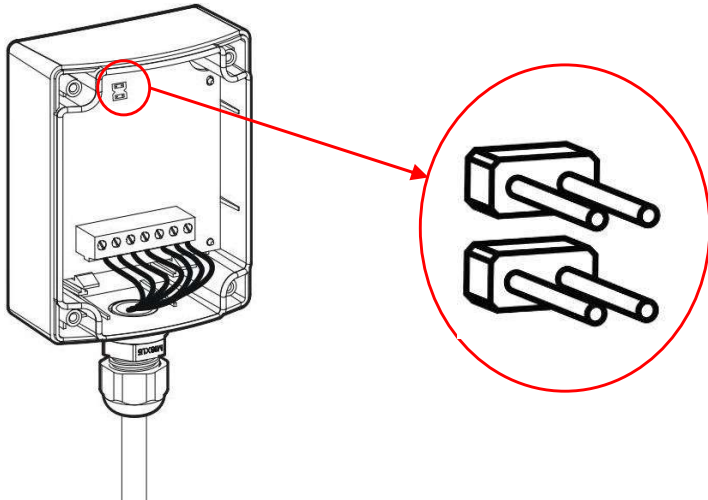

Jumper	Temp. Range
	-40°C ~ 60 °C (default)
	-20°C ~ 50 °C
	0°C ~ 50 °C

2. Wiring Diagrams: Wiring according to the wiring diagram corresponding to the model.

SKU
HSH-DV2A
HSH-DV2B
HSH-DV2P
HSH-DV3A
HSH-DV3B
HSH-DV3P
HSH-DV5A
HSH-DV5B
HSH-DV5P

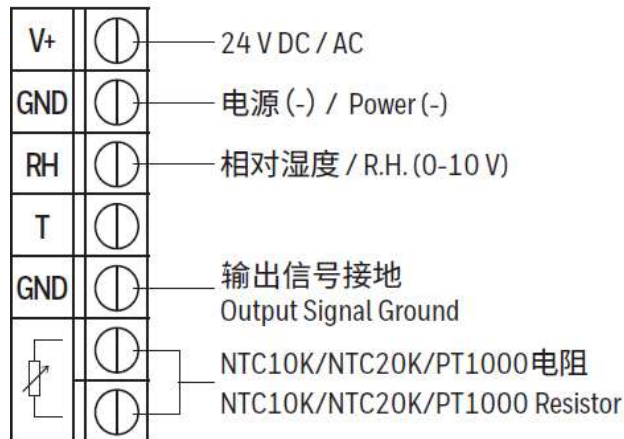

SKU
HSH-DM2A
HSH-DM2B
HSH-DM2P
HSH-DM3A
HSH-DM3B
HSH-DM3P
HSH-DM5A
HSH-DM5B
HSH-DM5P

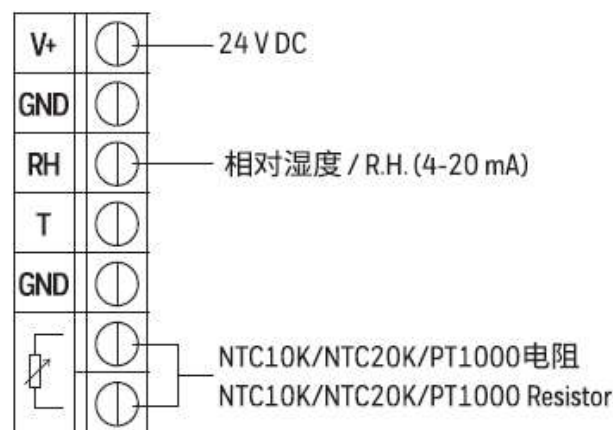

SKU
HSH-DM2M-X
HSH-DM3M-X
HSH-DM5M-X

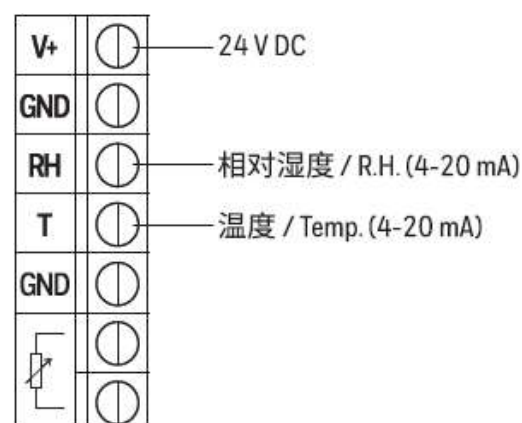

SKU
HSH-DV2V-X
HSH-DV3V-X
HSH-DV5V-X

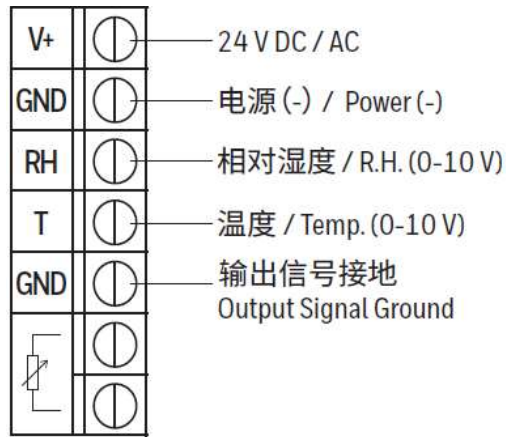

Tips:

1. Connection terminals are suitable for AWG15~22.
2. Due to the influence of wire resistance, the length of the cable between the sensor and the controller will cause the temperature drift. The details are as follows.

Wire gauge	permissible cable length	PT1000 Temp. drift every 10 meters cable	NTC10K / NTC20K Temperature shift
AWG 22	50m	0.272K	Negligible
AWG 20	150m	0.173K	
AWG 18	150m	0.109K	
AWG 17	150m	0.086K	
AWG 16	300m	0.069K	
AWG 15	300m	0.054K	

Dimension

Unit: mm

