

光纤传感器
(Fiber Optic Sensors)

光纤管
(Fiber tube)

光纤聚焦镜
(Fiber Focus Lens)

接近开关
(Proximity switch)

光电开关
(Photoelectric switch)

标签传感器
(Label sensor)

光幕传感器
(Light curtain)

激光对准线
(Laser alignment)

压力传感器
(Pressure sensor)

磁性开关
(Magnetic switch)

连接器
(Connector)

激光传感器
(Laser sensors)

色标传感器
(Color sensor)

导轨式电源
(Rail power supply)

固态继电器
(Solid State Relay)

光纤管
(Fiber tube)

光纤选型表
(Optical fiber Table)

漫反射光纤管
(Diffuse fiber coaxial tube)

漫反射同轴光纤管
(Diffuse fiber coaxial tube)

漫反射侧视型
(Diffuse side type)

漫反射矩阵型
(Diffuse matrix)

对射型光纤管
(Beam optical tube)

对射型侧视型
(Fiber tube Side Light)

对射式矩阵型
(Matrix on the radio)

直角光纤管
(Rectangular fiber)

支架光纤管
(Fiber tube stent)

特殊型光纤
(Special optical fiber)

槽型光纤管
(Groove tube fiber)

窗口型光纤
(window optical fiber)

耐高温玻璃光纤
(High temperature glass fiber)

LED冷光源
(LED cold light source)

光源光纤, 石英光纤
(Light fiber, quartz fiber)

FFT-610

M6普通对射光纤管
(M6 ordinary optical fiber tube on the radio)

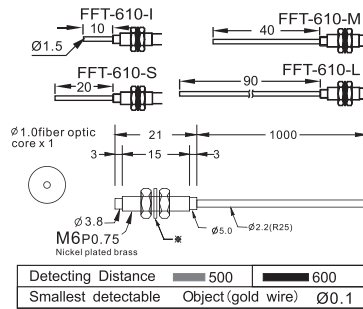

FFT-410

M4普通对射光纤管
(M4 ordinary optical fiber tube on the radio)



对射型 (Type of radio) ■ FF-12 ■ FF-301

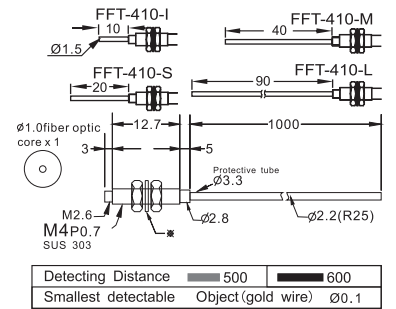

FFTX-610

M6粗芯对射光纤管
(M6 crude fiber tube on the radio core)

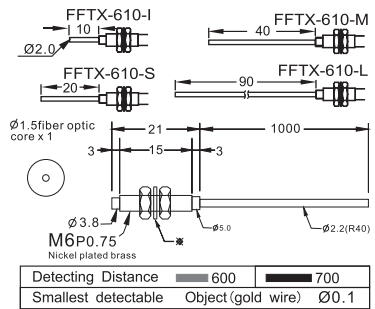

FFTX-410

M4粗芯对射光纤管
(M4 crude fiber tube on the radio core)

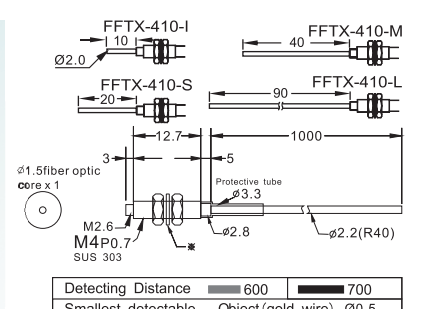

FFTH-610

M6耐高温对射光纤管
(M6 high temperature optical fiber tube on the radio)

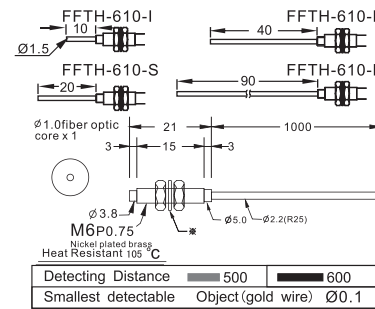

FFTB-410-Q

Φ4普通对射光纤管
(Φ4 ordinary optical fiber tube on the radio)

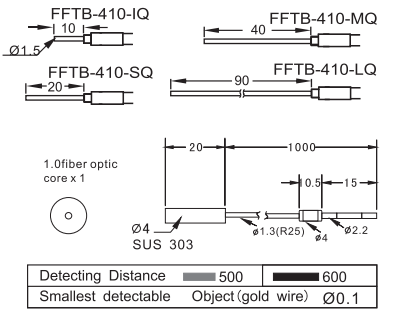

FFT-510-Q

Φ5系列对射光纤管
(through plastic fiber M5 Series)

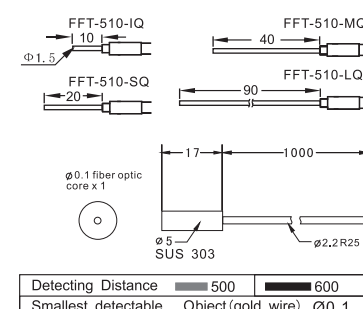

FFTS-410

M4细芯对射光纤管
(M4 small core optical fiber tube on the radio)

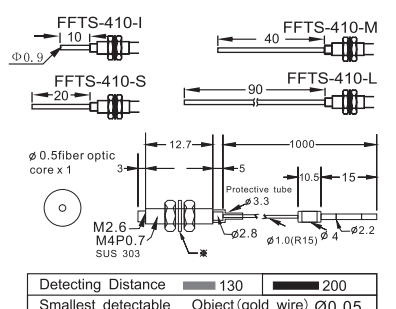

FFTX-510-Q

M5系列对射光纤管
(through plastic fiber M5 Series)

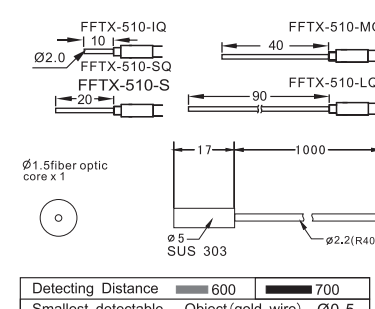

FFT-410-MU

M4凸管可弯曲对射光纤管
(M4 convex tube bending fiber tube on the radio)

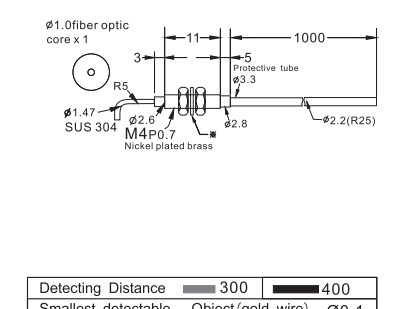

光纤 (Fiber)
尺寸 (单位: mm)
(Dimensions (Unit: mm))

对射型 (Type of radio) ■ FF-12 ■ FF-301

FFTB-410

M4普通对射光纤管
(M4 ordinary optical fiber tube on the radio)

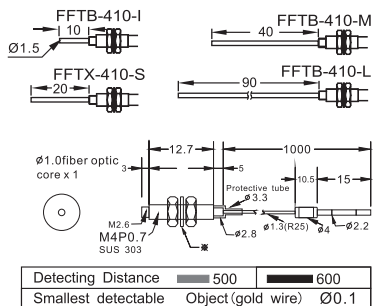

FFTW-310

M3柔软线对射光纤管
(M3 soft line on the radio fiber tube)

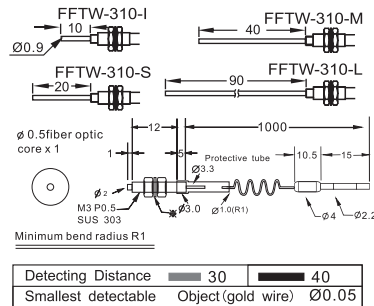

FFT-410-38G

M4系列对射光纤管
(through plastic fiber M4 Series)

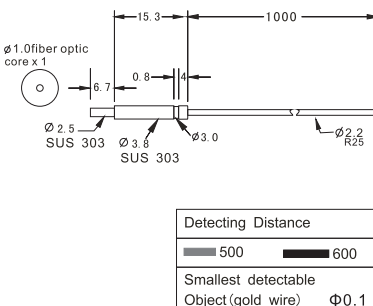

FFTW-310-Q

Φ3细芯柔软线对射光纤管
(Φ3 small core optical fiber tube soft line on the radio)

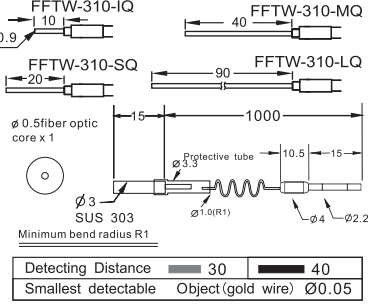

FFTH-410

M4耐高温对射光纤管
(M4 high temperature optical fiber tube on the radio)

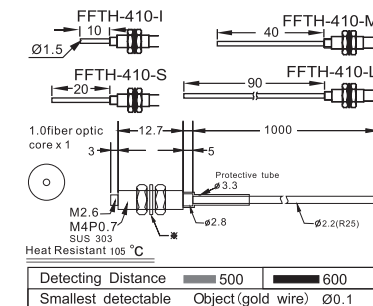

FFT-310

M3普通对射光纤管
(M3 ordinary optical fiber tube on the radio)

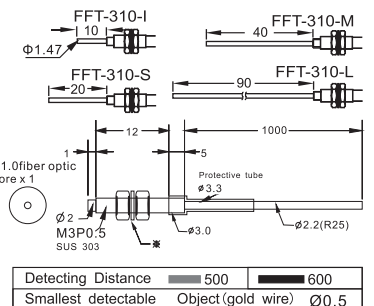

FFTE-4BEQ

Φ4超细对射光纤管
(Φ4 superfine fiber tube on the radio)
钻孔机专用
(Drilling machine for)

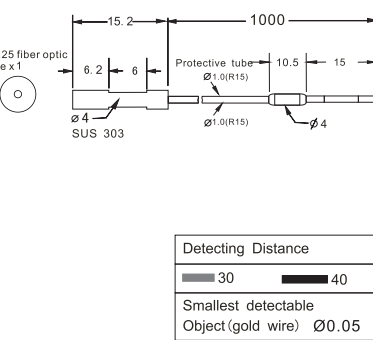

FFTC4-310

M3 4芯对射多芯光纤管
(M3 4-pin multi-core optical fiber tube on the radio)

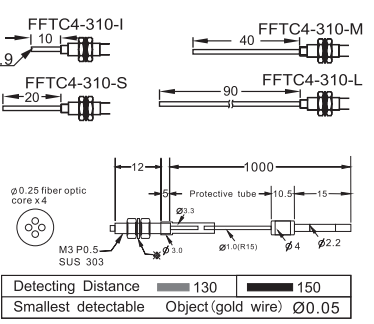
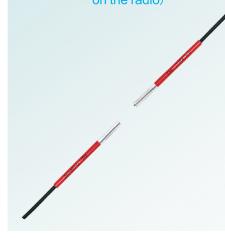

FFT-410-Q

M4普通对射光纤管
(M4 ordinary optical fiber tube on the radio)

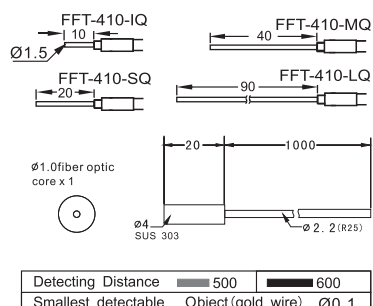

FFT-310-Q

Φ3普通对射光纤管
(Φ3 ordinary optical fiber tube on the radio)

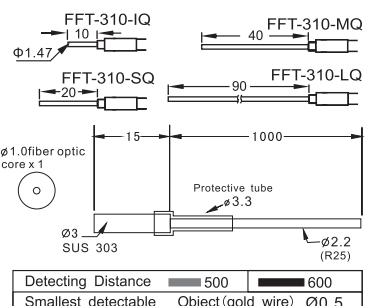

光纤传感器
(Fiber Optic Sensors)

光纤管
(Fiber tube)

光纤聚焦镜
(Fiber Focus Lens)

接近开关
(Proximity switch)

光电开关
(Photoelectric switch)

标签传感器
(Label sensor)

光幕传感器
(Light curtain)

激光对准线
(Laser alignment)

压力传感器
(Pressure sensor)

磁性开关
(Magnetic switch)

连接器
(Connector)

激光传感器
(Laser sensor)

色标传感器
(Color sensor)

导轨式电源
(Rail power supply)

固态继电器
(Solid State Relay)

光纤管
(Fiber tube)

光纤选型表
(Optical fiber Table)

漫反射光纤管
(Diffuse fiber coaxial tube)

漫反射同轴光纤管
(Diffuse fiber coaxial tube)

漫反射侧视型
(Diffuse side type)

漫反射矩阵型
(Diffuse matrix)

对射型光纤管
(Beam optical tube)

对射型侧视型
(Fiber tube Side Light)

对射式矩阵型
(Matrix on the radio)

直角光纤管
(Rectangular fiber)

支架光纤管
(Fiber tube stent)

特殊型光纤
(Special optical fiber)

槽型光纤管
(Groove tube fiber)

窗口型光纤
(window optical fiber)

耐高温玻璃光纤
(High temperature glass fiber)

LED冷光源
(LED cold light source)

光源光纤、石英光纤
(Light fiber, quartz fiber)

- 光纤传感器 (Fiber Optic Sensors)
- 光纤管 (Fiber tube)
- 光纤聚焦镜 (Fiber Focus Lens)
- 接近开关 (Proximity switch)
- 光电开关 (Photoelectric switch)
- 标签传感器 (Label sensor)
- 光幕传感器 (Light curtain)
- 激光对准线 (Laser alignment)
- 压力传感器 (Pressure sensor)
- 磁性开关 (Magnetic switch)
- 连接器 (Connector)
- 激光传感器 (Laser sensors)
- 色标传感器 (Color sensor)
- 导轨式电源 (Rail power supply)
- 固态继电器 (Solid State Relay)

- 光纤管 (Fiber tube)
- 光纤选型表 (Optical fiber table)
- 漫反射光纤管 (Diffuse fiber coaxial tube)
- 漫反射同轴光纤管 (Diffuse fiber coaxial tube)
- 漫反射侧视型 (Diffuse side type)
- 漫反射矩阵型 (Diffuse matrix)
- 对射型光纤管 (Beam optical tube)
- 对射型侧视型 (Fiber tube Side Light)
- 对射式矩阵型 (Matrix on the radio)
- 直角光纤管 (Rectangular fiber)
- 支架光纤管 (Fiber tube stent)
- 特殊型光纤 (Special optical fiber)
- 槽型光纤管 (Groove tube fiber)
- 窗口型光纤 (window optical fiber)
- 耐高温玻璃光纤 (High temperature glass fiber)
- LED冷光源 (LED cold light source)
- 光源光纤, 石英光纤 (Light fiber, quartz fiber)

FFTB-310

M3普通对射光纤管
(M3 ordinary optical fiber tube on the radio)

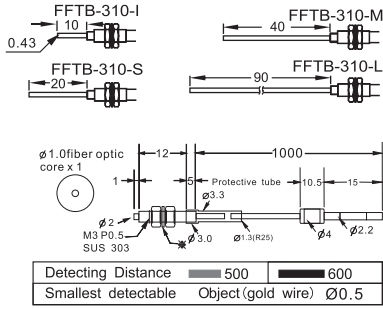

FFTS-310-Q

Φ3细芯对射光纤管
(Φ3 small core optical fiber tube on the radio)

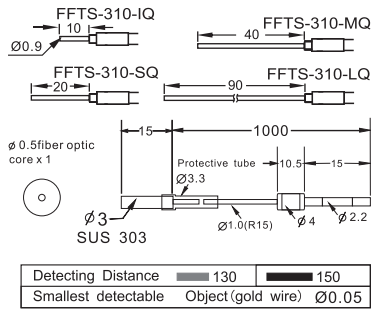

FFTE-310-Q

Φ3超细芯对射光纤管
(Φ3 superfine fiber tube on the radio core)

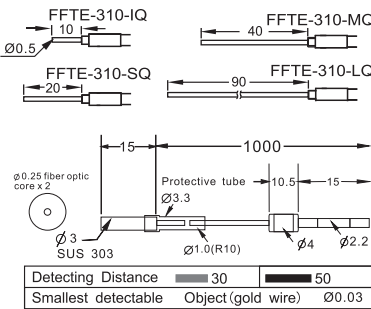

FFTS-310

M3普通对射光纤管
(M3 ordinary optical fiber tube on the radio)

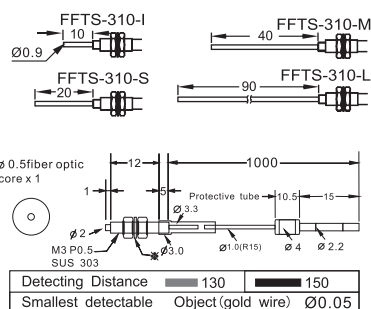

FFTC9-310-Q

Φ3 9芯对射光纤管
(Φ3 9 core optical fiber tube on the radio)

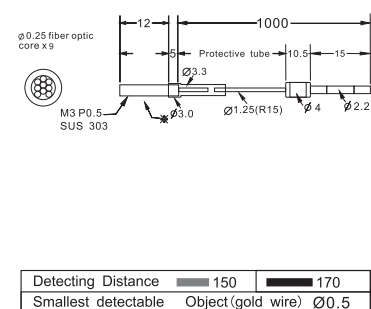

FFTC16-310

M3多芯对射光纤管
(M3 Multi-core optical fiber tube on the radio)

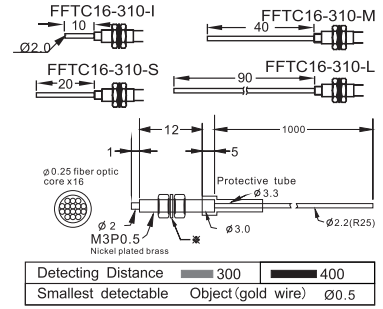

FFTE-310

M3超细芯对射光纤管
(M3 core of ultra-fine fiber tube radio)

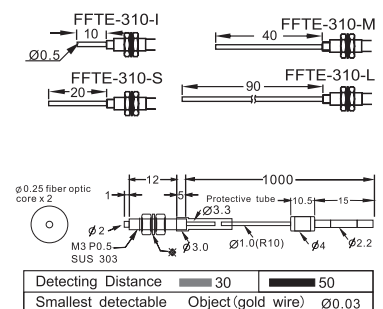

FFTS-310-4

M4 4头定位光纤
(M4 4 positioning fiber)

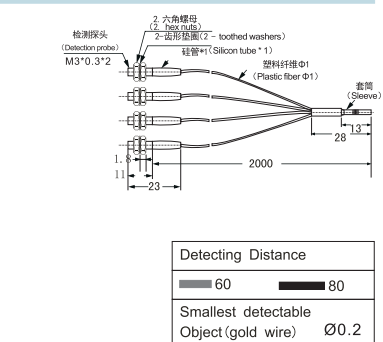

FFTK-305-43MMQ

Φ0.3凸管特细对射光纤
(Φ0.3 convex tube super fine fiber on the radio)

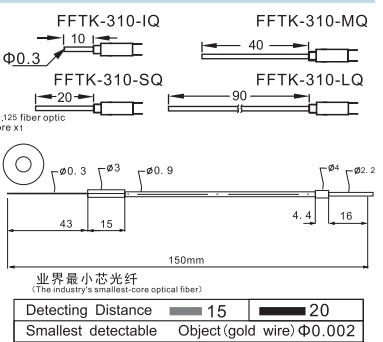

FFTE-280L/600L

Φ3系列对射光纤管
(through plastic fiber Φ3 Series)

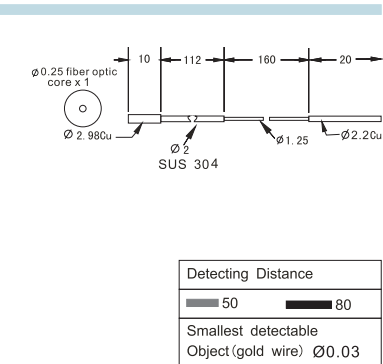

光纤 (Fiber)
尺寸 (单位: mm)
(Dimensions (Unit: mm))

对射型 (Type of radio) ■ FF-12 ■ FF-301

FFTC4-321A-15

Φ3 4芯对射光纤管
(Φ3 4-core optical fiber tube on the radio)
钻孔机专用
(Drilling machine for)

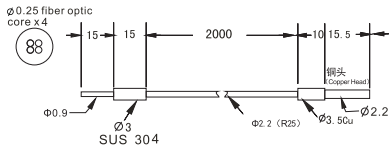

Detecting Distance	100	150
Smallest detectable	Object (gold wire) Φ0.05	

FFTE-210

Φ2超细芯对射光纤管
(Φ2 superfine fiber tube on the radio core)

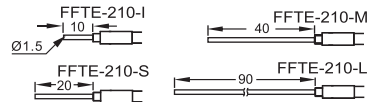

Detecting Distance	30	40
Smallest detectable	Object (gold wire) Φ0.03	

FFTC4-310-Q

Φ3 4芯对射光纤管
(Φ3 4-core optical fiber tube on the radio)

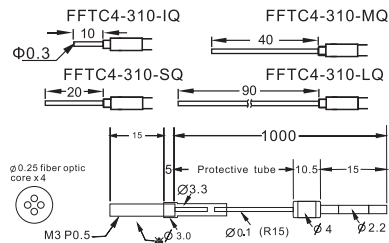

Detecting Distance	130	150
Smallest detectable	Object (gold wire) Φ0.05	

FFTS-210

Φ2普通对射光纤管
(Φ2 ordinary optical fiber tube on the radio)

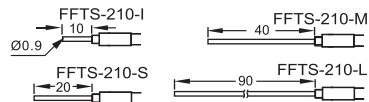

Detecting Distance	100	120
Smallest detectable	Object (gold wire) Φ0.03	

FFTC9-310

M3 9芯对射光纤管
(M3 9-core optical fiber tube on the radio)

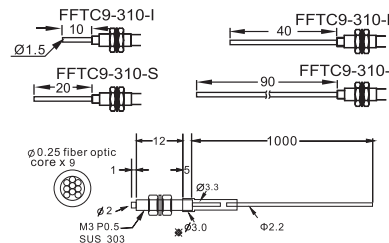

Detecting Distance	150	170
Smallest detectable	Object (gold wire) Φ0.05	

FFTC4-210

Φ2 4芯对射光纤管
(Φ2 4-core optical fiber tube on the radio)

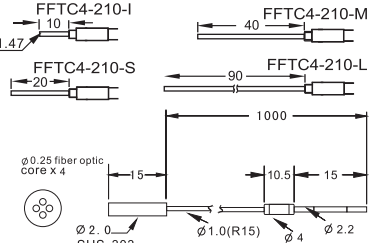

Detecting Distance	100	120
Smallest detectable	Object (gold wire) Φ0.05	

FFTC9-210

Φ2 9芯对射光纤管
(Φ2 9-core optical fiber tube on the radio)

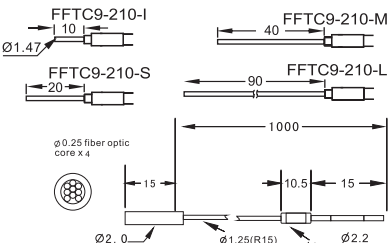

Detecting Distance	100	120
Smallest detectable	Object (gold wire) Φ0.03	

FFTE-1510-H10

Φ1.5超细芯对射光纤管
(Φ1.5 fine core optical fiber tube on the radio)

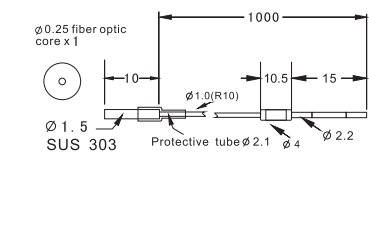

Detecting Distance	30	40
Smallest detectable	Object (gold wire) Φ0.03	

FFTA-210

Φ2超细芯对射光纤管
(Φ2 superfine fiber tube on the radio core)

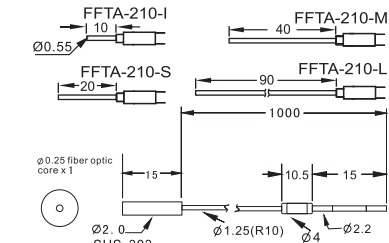

Detecting Distance	300	400
Smallest detectable	Object (gold wire) Φ0.5	

FFTE-1510

Φ1.5超细芯对射光纤管
(Φ1.5 fine core optical fiber tube on the radio)

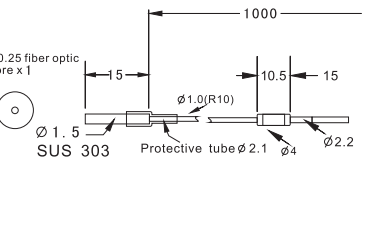

Detecting Distance	30	40
Smallest detectable	Object (gold wire) Φ0.03	

光纤传感器
(Fiber Optic Sensors)

光纤管
(Fiber tube)

光纤聚焦镜
(Fiber Focus Lens)

接近开关
(Proximity switch)

光电开关
(Photoelectric switch)

标签传感器
(Label sensor)

光幕传感器
(Light curtain)

激光对准线
(Laser alignment)

压力传感器
(Pressure sensor)

磁性开关
(Magnetic switch)

连接器
(Connector)

激光传感器
(Laser sensors)

色标传感器
(Color sensor)

导轨式电源
(Rail power supply)

固态继电器
(Solid State Relay)

光纤管
(Fiber tube)

光纤选型表
(Optical fiber Table)

漫反射光纤管
(Diffuse fiber coaxial tube)

漫反射同轴光纤管
(Diffuse fiber coaxial tube)

漫反射侧视型
(Diffuse side type)

漫反射矩阵型
(Diffuse matrix)

对射型光纤管
(Beam optical tube)

对射型侧视型
(Fiber tube Side Light)

对射式矩阵型
(Matrix on the radio)

直角光纤管
(Rectangular fiber)

支架光纤管
(Fiber tube stent)

特殊型光纤
(Special optical fiber)

槽型光纤管
(Groove tube fiber)

窗口型光纤
(window optical fiber)

耐高温玻璃光纤
(High temperature glass fiber)

LED冷光源
(LED cold light source)

光源光纤、石英光纤
(Light fiber, quartz fiber)

- 光纤传感器 (Fiber Optic Sensors)
- 光纤管 (Fiber tube)
- 光纤聚焦镜 (Fiber Focus Lens)
- 接近开关 (Proximity switch)
- 光电开关 (Photoelectric switch)
- 标签传感器 (Label sensor)
- 光幕传感器 (Light curtain)
- 激光对准线 (Laser alignment)
- 压力传感器 (Pressure sensor)
- 磁性开关 (Magnetic switch)
- 连接器 (Connector)
- 激光传感器 (Laser sensors)
- 色标传感器 (Color sensor)
- 导轨式电源 (Rail power supply)
- 固态继电器 (Solid State Relay)

FFTE-1510-5

Φ0.25超细芯对射光纤管
(Φ0.25 fine core optical fiber tube on the radio)

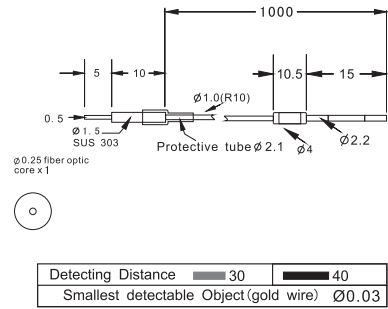

FFTE-1510-H5

Φ0.25超细芯对射光纤管
(Φ0.25 fine core optical fiber tube on the radio)

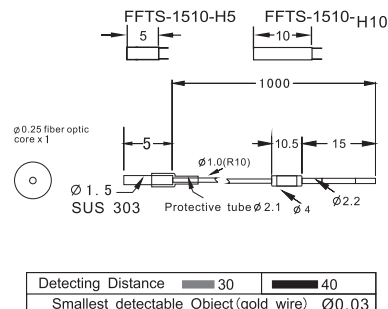

FFTS-1510

Φ0.5细芯对射光纤管
(Φ0.5 small core optical fiber tube on the radio)

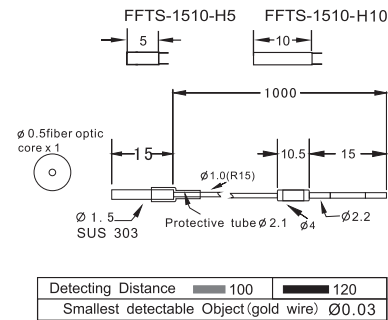

FFTC4-1510

Φ0.25*4细芯对射光纤管
(Φ0.25 * 4 thin-core optical fiber tube on the radio)

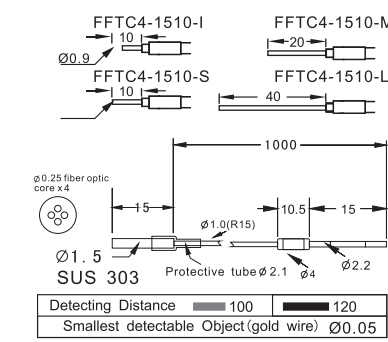

FFT-59

Φ0.25*4细芯对射光纤管
(Φ0.25 * 4 thin-core optical fiber tube on the radio)

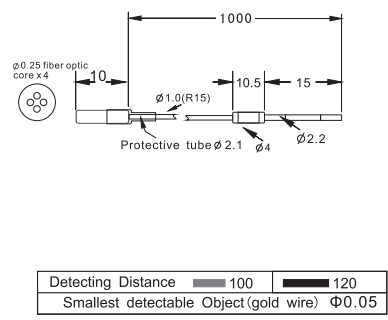

对射型 (Type of radio) ■ FF-12 ■ FF-301

FFTK-1510-Q

Φ0.3凸管特细对射光纤管
(Φ0.3 convex tube super fine fiber on the radio)
业界最细光纤管
(The industry's smallest optical tube)

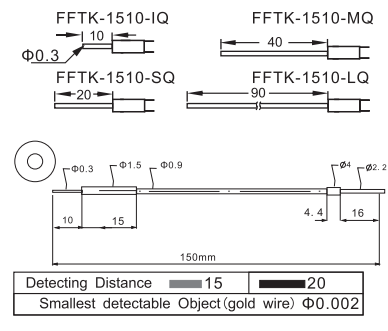

配件类 (Accessories)

螺母 (单位: mm)
(Nut (unit: mm))

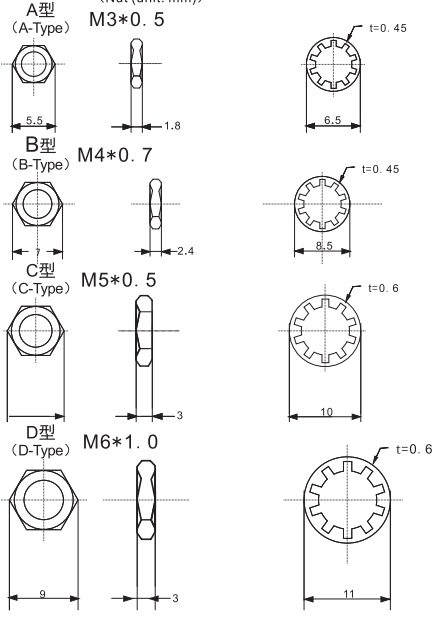

M3直角安装支架
(M3 right angle mounting bracket)

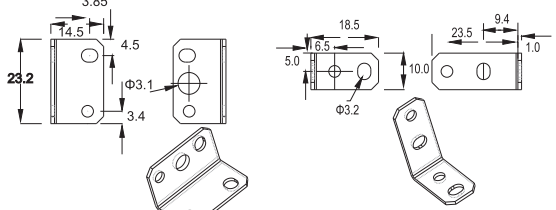

M4直角安装支架
(M4 right angle mounting bracket)

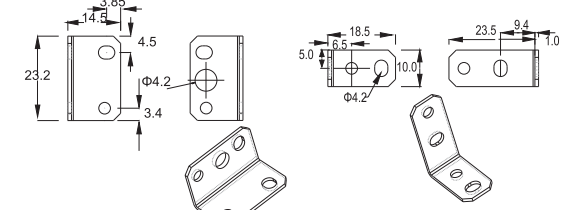

M6直角安装支架
(M6 right angle mounting bracket)

