



PRESENT & BEYOND

We Share

We Plan

We Do

We Care

Step Forward To The World Of Automation

No.26, JALAN IKS SIMPANG EMPAT,
TAMAN IKS SIMPANG EMPAT,
14100 SIMPANG AMPAT,
PENANG, MALAYSIA

Hotline : 1700 81 8800
Tel : 04 504 1288
Fax : 04 504 1980
Email : enquiry@sck-group.com
Web : www.sck-group.com



Website : www.sck-group.com
Email : enquiry@sck-goup.com

CONTENTS

01 About Us



2 OUR Project Reference

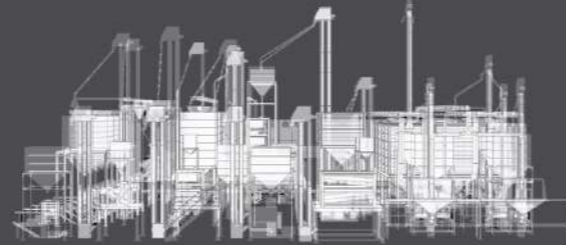

3 **SCK GROUP** Packing Solution & Conveyor System

- 3. Auto Packer
- 4. Rotary Packer
- 5. Semi Auto Packer
- 6. Inline Check Weigher
- 7. Traffic Conveyor System
- 8. CMC System

11 Shutter Scale
- Batch Weigher
- 1 Ton Weigher

9 **Būivānngō** Rice Processing Machine



12 **Volumetric** Packing Solution

10 **KUKA** Palletizing System



13 **HOME** Automation System

14 **ECO** Dust Filter Environment Solution

Present Beyond



About Us

OUR PROJECT REFERENCES

We established in 2009, we are total solution provider in Packaging and Industrial Automation System. our vision of supplying affordable, reliable and quality product and systems.

Visit us @ www.sck-grop.com

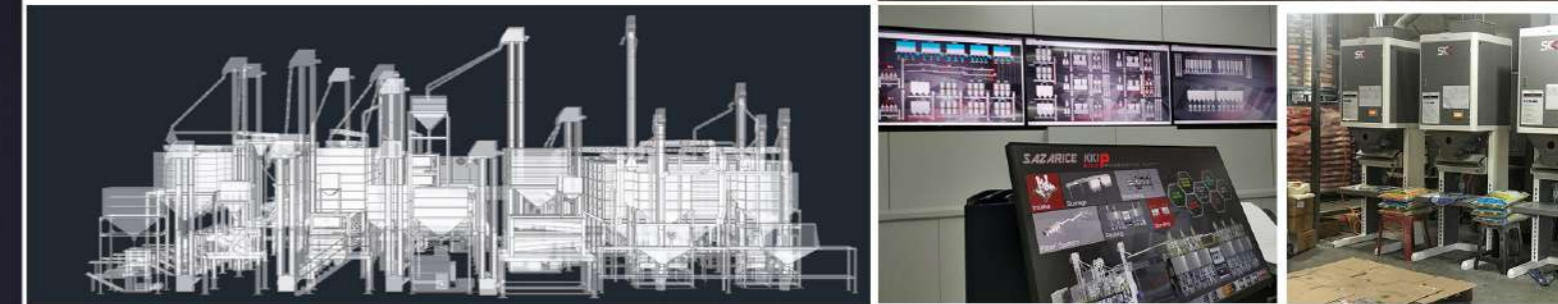

Our Mission

Delivered our products know-how and up-to-date information to our value business partner. Share and provide total solution to our value business partner in order to automate their production for increase their productivity. Responsibility to serve our customer with our technical know-how and quality products.



Objective

Being the most preferred solution provider in Agricultural, Packaging & Industrial Automation Segment

iAP-Family

The Intelligent Auto Packer



iBL-100 Intelligent Bag Lifter

Holding Capacity : 100kg
Function : Auto Bag Loading



IAP



IAP-T

SPECIFICATION

Model	Bag/Hour	Packing Range (kg)	Auto Bag Adjustment Function	Recipe Mode	Pressure Bar/psi	Power	Weighing Tolerance	Dimensions (mm) (W x L x H)
iAP-1480	360-540	0.5-15	Auto	1-20	6/87	AC 415V	+ - 8g	1050 x 1520 x 2200
iAP-2840-T	420-1080	0.5-15	Auto	1-40	6/87	AC 415V	+ - 8g	2000 x 1500 x 2200

Intelligent Rotary Packer

iRP-3840

Intelligent Semi-Auto Packer

iSP-1240

SPECIFICATION

- PACKING RANGE : 3-10KG
- CAPACITY : 12-18 BAG/MIN
- RECIPE MODE : 30 MODE
- FUNCTION : AUTO ADJUSTMENT BAG
- WEIGHER : 3 SET WEIGHING BUFFER
- WEIGHING TOLERANCE : +/-10G
- AIR PRESSURE : 6 BAR / 87 PSI
- POWER : AV 415V
- DIMENSIONS : W2750 X L1800 X H3048

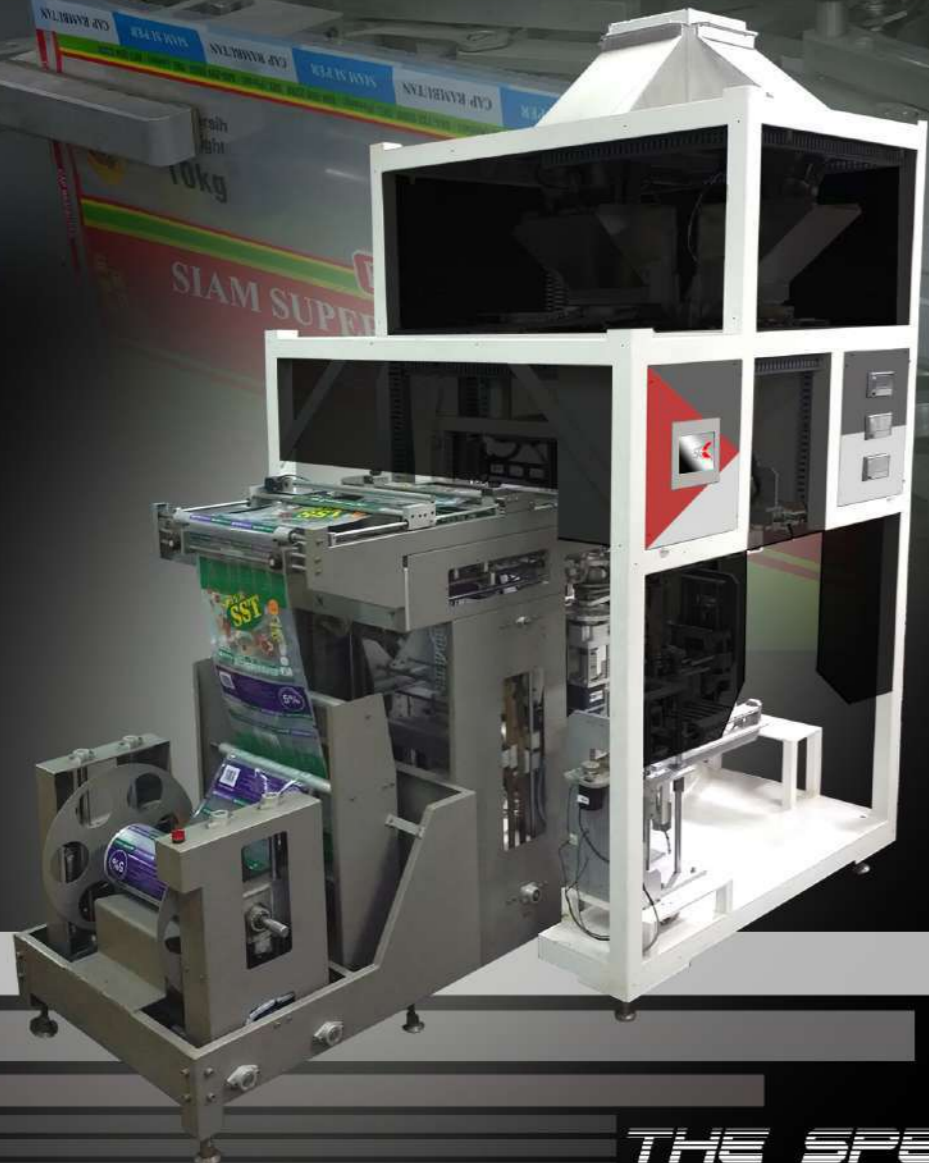

THE SPEED OF ROTARY

THE NEW CONCEPT OF SEMI-AUTO PAKER

EASY TO OPERATE

LOW MAINTENACE

ALARM MESSENGER

INDICATION WEIGHT DISPLAY

FAST SEALING

HUMAN MACHINE INTERFACE

3 Step Design Shutter

Weighing Tolerance : +/- 10g



Function : 4 Recipe Mode



Control By : Touch Panel (HMI)

Weighing Range : 1-50kg



Air Pressure : 5Bar / 72psi

Packing Speed : 180-240 Bag/Hour



Dimension (mm): W670 x D720 x H2400



INLINE CHECK WEIGHER

INLINE 4 MODE RECIPE
AT THE SAME TIME

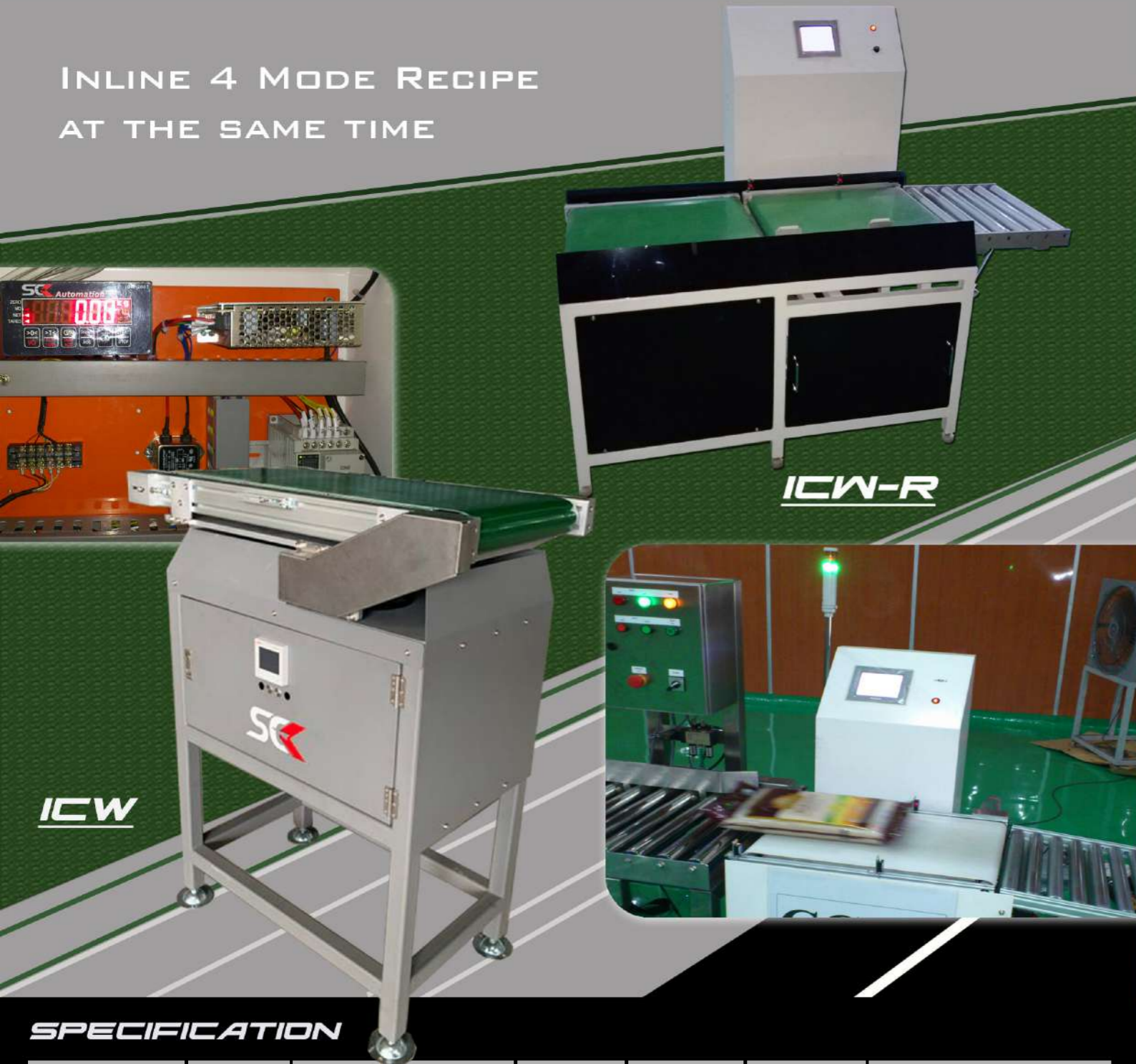

ICW-R

ICW

SPECIFICATION

Model	Capacity Ton/Hour	Batch KG Max	Tolerance	Power	Pressure Bar/psi	Speed Bag/Min	Dimensions (mm) (D x W x H)
iCW-400	15	1-5	+ - 0.1%	240V	5/72	10-18	700 x 1050 x 1300
iCW-R-400	25	1-5	+ - 0.1%	240V	5/72	10-20	850 x 1500 x 1450
iCW-600	30	1-10	+ - 0.1%	240V	5/72	10-18	1000 x 1800 x 1500

YOUR TRAFFIC CONVEYOR SOLUTION

HIGH QUALITY BELT
&
HIGH TENSILE ALUMINUM PROFILE



IPB

Model	WIDTH	LENGTH	HIGH	Power	KW	Loading Capacity	Speed m/sec
iPB-FT	300/400/500/600	1000-3000	200-1000	240V	0.4-1.5kw	10-50kg	0.3-1.0
iPB-IN	300/400/500/600	1000-3000	200-1000	240V	0.4-1.5kw	10-50kg	0.3-0.8



ICF-800
CONTROL FEEDER

THE RICE BLENDING MACHINE

Blending Recipe
Product Name List

No.	Product Name	Ton	519	520	521	522	523	524	525	526
		Hour	%	%	%	%	%	%	%	%
1										
2										
3										
4										
5										
6										
7										
8										
9										
10										

Recipes
Memory
Mode

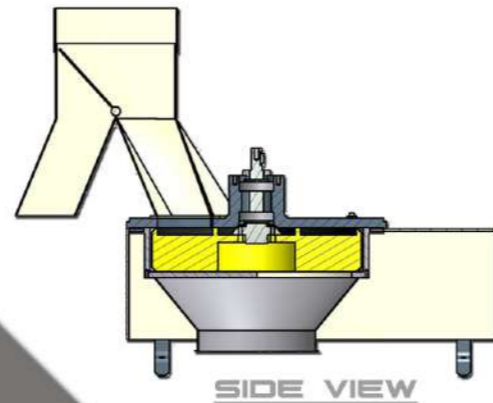

Blending Recipe
Line 1, Line 2 Control Feeder Recipe

Ton	No.	Line 1 Product Name	Ton	No.	Line 2 Product Name
0			0		
CF1			CF9		
CF2			CF10		
CF3			CF11		
CF4			CF12		
CF5			CF13		
CF6			CF14		
CF7			CF15		
CF8			CF16		

RUN STOP AUTO Manual Run CF RUN STOP
Line 1 Line 2

Volumetric Control System

No. Ton Product Name
1 10 Product AAA

H18 H19 H20 H21 H22
BB10 BB11 BB12 BB13 BB14

L18 L19 L20 L21 L22
30% 50% 20%

CF1 CF2 CF3 CF4 CF5

Call Recipe

Easy Formula Setting, Auto Calculation
System, Message Display, Data Logging Display,
HMI Remote Viewer, Control By PLC & HMI Interface.

HIGH ACCURACY

Power - 300W ACV

Speed - 5-100 Rpm

Capacity - 6-8 TPH

Function - Recipe Blending

Features - Built in Inverter For Easy Control

Dimension (mm) - W450 x L600 x H360



Pre-Cleaner



Destoner



Shutter Scale



Sewing Machine & Belt Conveyor



Whitener



Thickness Grader



Inline Weigher



Color Sorter



Polisher



Rice Whitening Machine



Paddy Husker



Length Grader



Rotary Sifter



Paddy Separator

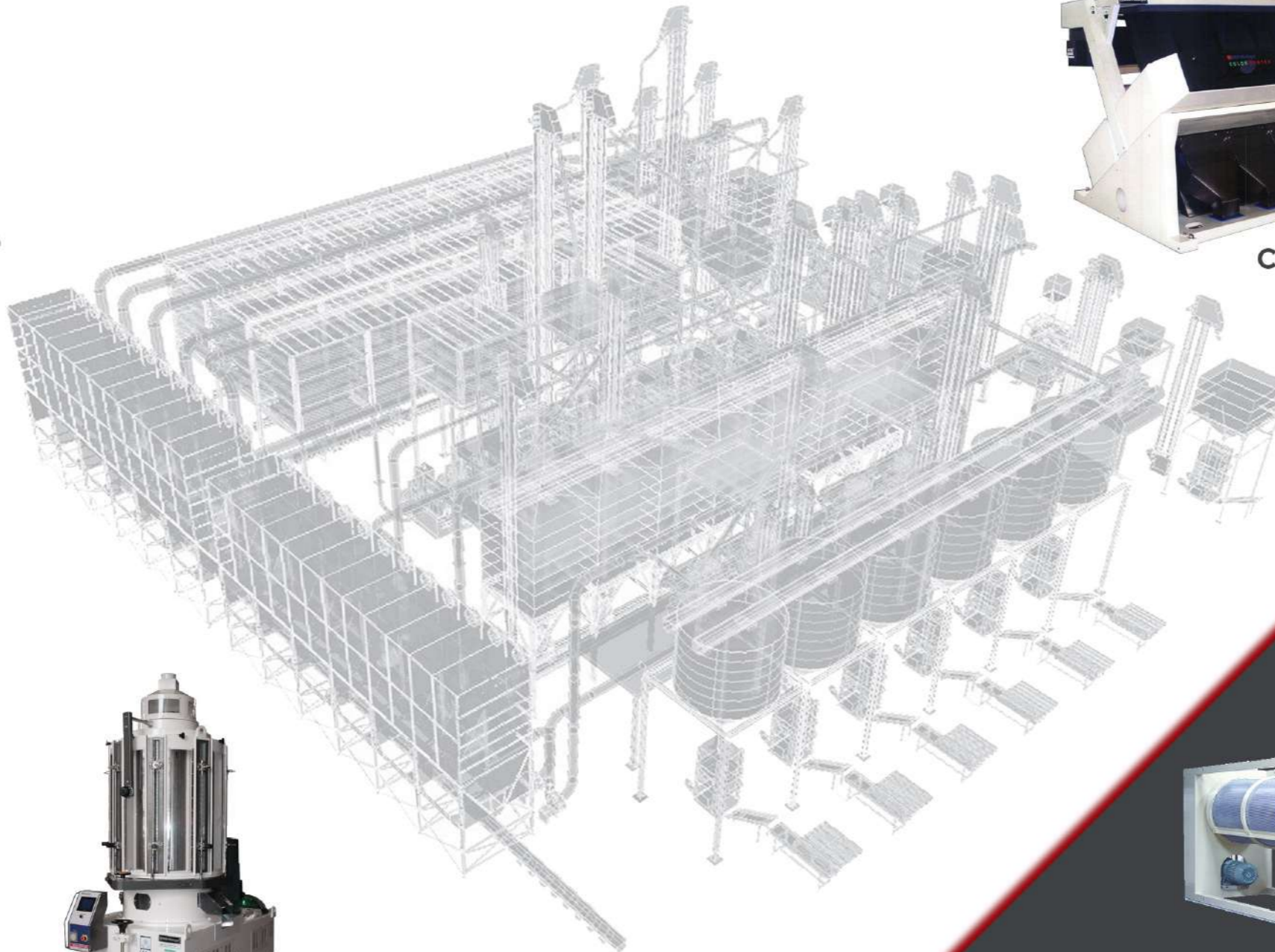

KUKA

Your Palletizing Solution
KR-PA SERIES





THE **iSS** SERIES

BATCH WEIGHING SCALE

STAINLESS STEEL FOR FOOD GRADE



i1T-30

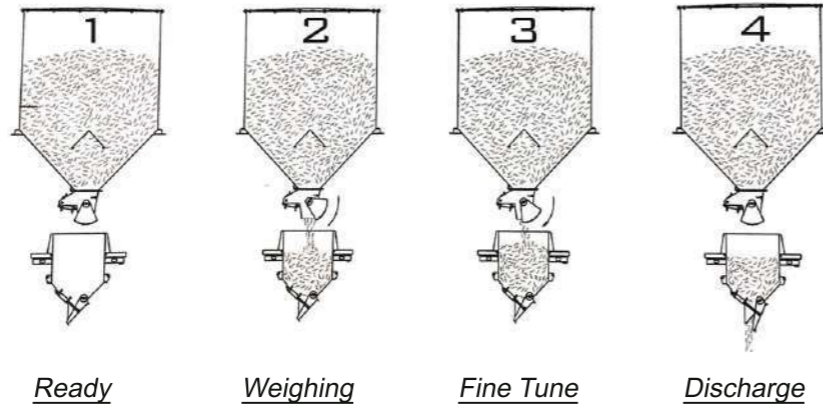

iSS-25



iSS-15



Valumetric Consist Of Servo Motor For High Precision



PLC System With High Resolution Touch Panel

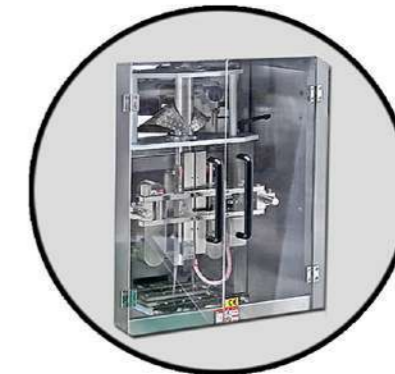

Safety Door Cover

Central Seal Type (Top, Back & Bottom)

SPECIFICATION

Model	Capacity Ton/Hour	Batch KG Max	Tolerance	Power	Pressure Bar/psi	Dimensions (mm) (D x W x H)
iSS-15	15	50	+/- 0.1%	240V	5/72	2193 x 1420 x 4185
iSS-25	25	50	+/- 0.1%	240V	5/72	2264 x 1420 x 4404
iSS-30	30	50	+/- 0.1%	240V	5/72	2215 x 2215 x 5505
i1T-30	30	1000	+/- 0.1%	240V	5/72	1524 x 1824 x 6500

SPECIFICATION

Model : iVM-130V
 Packing Range : 100g - 1000g
 Packing Speed : 25-30 Bag/min
 Sealing Type : 3 Seal (Pillow Bag)
 Bag Size : W 60-200 mm / L 60-300 mm
 Film Width : 140-420 mm
 Film Thickness : 0.04-0.09 mm
 Power : AC220V (Single Phase)
 Air Pressure : 0.7-0.8 Mpa

Dimension

L-1260mm

W-1015mm

H-1568mm

HUMAN MACHINE INTERFACE



CCTV



SENSOR



L.E.D

SMART HOME SYSTEM

HOME AUTOMATION IS "THE INTERNET OF THINGS"... THE WAY THAT ALL OF OUR DEVICES AND APPLIANCES WILL BE NETWORKED TOGETHER TO PROVIDE US WITH A SEAMLESS CONTROL OVER ALL ASPECTS OF OUR HOME AND MORE. HOME AUTOMATION HAS BEEN AROUND FROM MANY DECADES IN TERMS OF LIGHTING AND SIMPLE APPLIANCE CONTROL, AND ONLY RECENTLY HAS TECHNOLOGY CAUGHT UP FOR THE IDEA OF THE INTERCONNECTED WORLD, ALLOWING FULL CONTROL OF YOUR HOME FROM ANYWHERE, TO BECOME A REALITY. WITH HOME AUTOMATION, YOU DICTATE HOW A DEVICE SHOULD REACT, WHEN IT SHOULD REACT, AND WHY IT SHOULD REACT. YOU SET THE SCHEDULE AND THE REST IS AUTOMATED AND BASED OFF OF YOUR PERSONAL PREFERENCES THUS PROVIDING CONVENIENCE, CONTROL, MONEY SAVINGS, AND AN OVERALL SMARTER HOME. HOME AUTOMATION CAN ALSO ALERT YOU TO EVENTS THAT YOU MIGHT WANT TO KNOW ABOUT RIGHT-AWAY WHILE YOU ARE GONE LIKE WATER LEAKS AND UNEXPECTED ACCESS TO YOUR HOME, OR ANY PART OF IT. AT ANY TIME, YOU CAN GRAB YOUR IPHONE, ANDROID DEVICE OR OTHER REMOTE CONTROL AND CHANGE THE SETTINGS IN YOUR HOUSE AS DESIRED.



CONTROLLER



REMOTE HMI



SMART LOCK

eco ENVIRONMENT SOLUTION DUST FILTER

GROUP OF COMPANY

- . SCK AUTOMATION SDN. BHD.
- . SCK INTEGRATION SDN. BHD.

SYSTEM PARTNER

- . NCH GREENTECH SOLUTION SDN. BHD.
- . NCH NORTHERN ENGINEERING SDN. BHD.

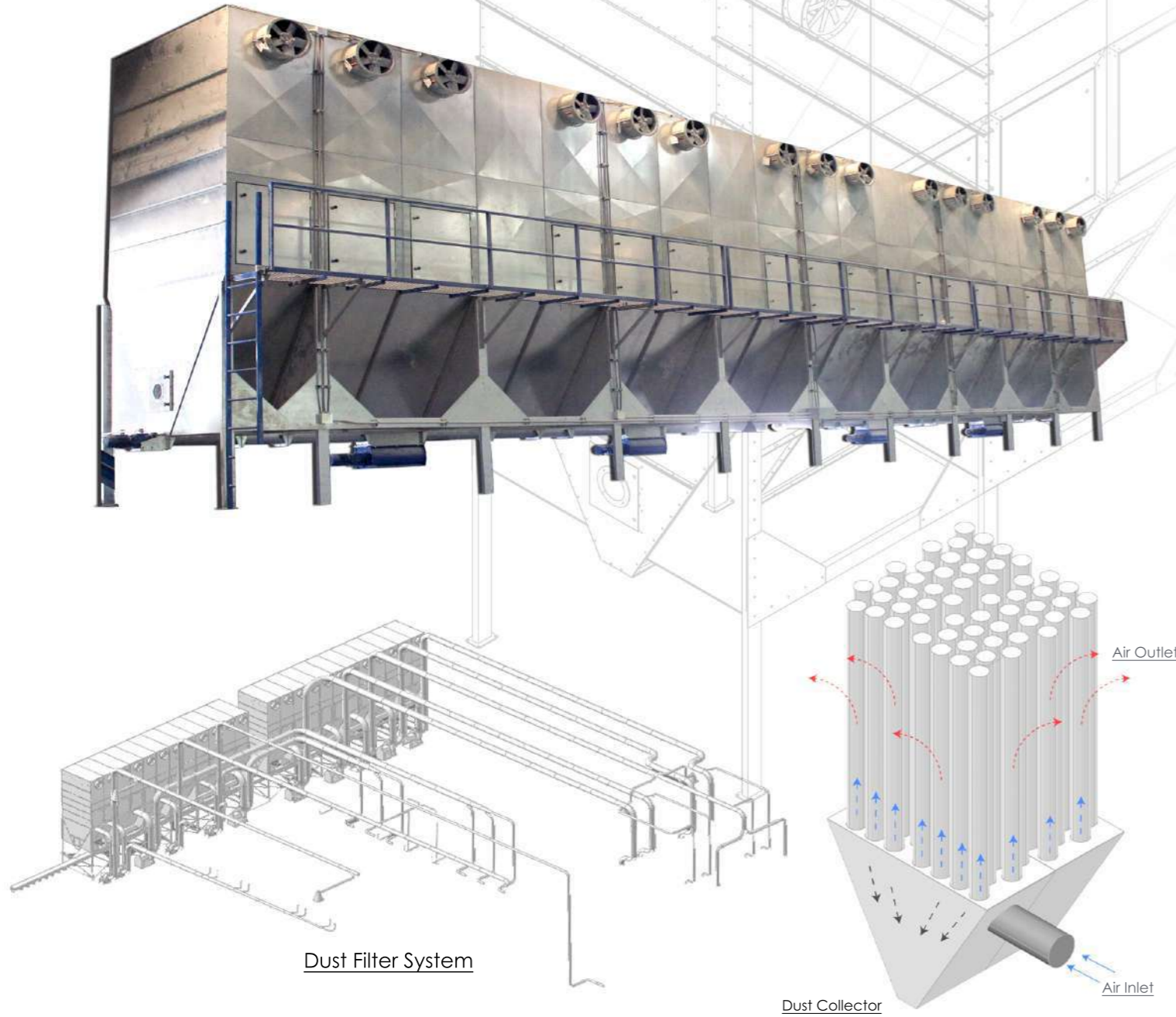

Dust Filter System

Dust Collector

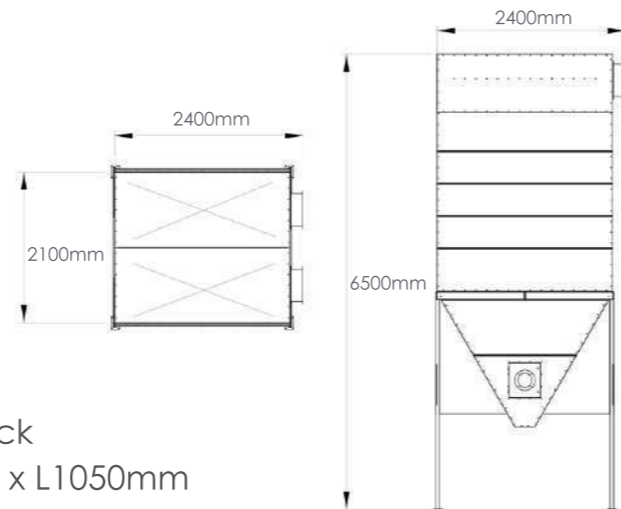

SPECIFICATION:

Model - NCH-DF

- Type - Positive Modular Filter
- Filter Area - 58 m²/module
- Filter Bag Length - 2850mm
- Filter Media Origin - Andrew Webron
- Cleaning Method - Auto Reverse Air
- Discharge Method - Chain Conveyor c/w Air Lock
- Dimension One Module - H6500mm x W2400mm x L1050mm

