

EXTRA RANGE OPTIONS AND ACCESSORIES

SUPPORT LEGS and SIDE GUIDES

Recommended Number of Pairs of Support Legs per Conveyor Length

Conveyor Length→ Conveyor Type↓	Up to 550cm	600 to 850cm	900 to 1150cm	1200 to 1450cm	1500 to 1750cm	1800 to 2050cm	2100 to 2350cm
APM4	2	3	4	5	6	7	8
APM5	2	3	4	5	6	7	8

Conveyor Length→ Conveyor Type↓	2400 to 2650cm	2700 to 2950cm	3000cm	3050 to 3250cm	3300 to 3550cm	3600 to 3850cm	3900 to 4000cm
APM4	9	10	11	-	-	-	-
APM5	9	10	11	11	12	13	14

❖ APM4 and APM5 Drive Unit acts as one pair of Support Leg.

Sample Model Selection (Support Legs)

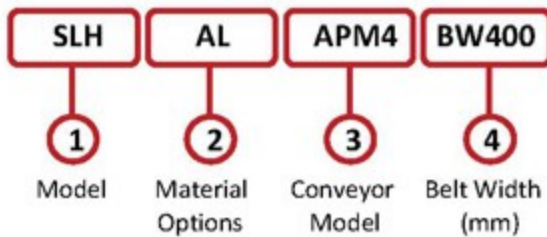

Model Selection Table (Support Legs)

1 Model	SLH, SLS1, SLS2	
2 Material Options	AL	40 x 40mm Aluminium Profile
	MS	32 x 32mm x 1.6t Mild Steel Square Hollow Section
	SUS	32 x 32mm x 1.5t Stainless Steel Square Hollow Section
3 Conveyor Model	M400, M500	
4 Belt Width	Up to 1000mm (in 50mm increments)	
Conveyor Height	750mm +/- 25	
Remarks	Standard Round Type Base Washer	

❖ Standard increments for Belt Width and Height = 50mm

Aluminium Profiles

Conveyor Model	Conveyor Frame	Support Leg Frame	Options and Accessories
APM4			Support Leg : SLH, SLS1, SLS2 Side Guide : L32B, AG1B, AG5B, PG1B, PG5B Other Accessories : Instruction Manual Holder, Hanger Rail, Lighting, Shelving, Side Table, Compressed Air Piping, Foot Rest/Bracing
APM5			Support Leg : SLH, SLS1, SLS2 Side Guide : L32A, AG1A, AG5A, PG1A, PG5A Other Accessories : Instruction Manual Holder, Hanger Rail, Lighting, Shelving, Side Table, Compressed Air Piping, Foot Rest/Bracing

simple • reliable • quality • value

Conveyor Model: **APM4**

SUPPORT LEGS

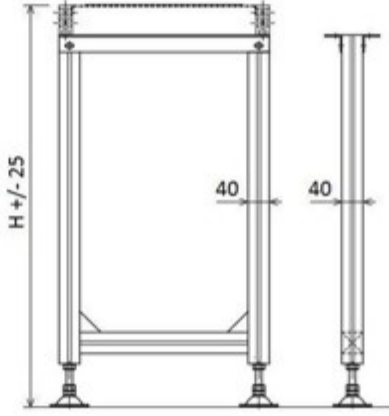
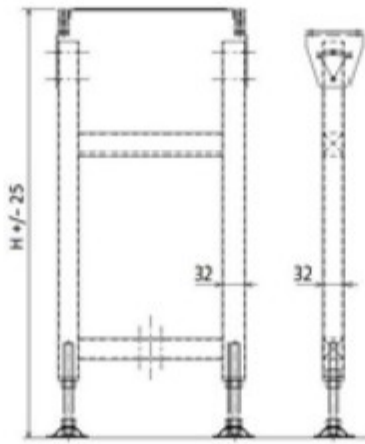
SLH – AL	SLH – MS / SUS
	
Material : 40 x 40mm Aluminium Profile Height (H) : 750mm +/- 25mm	Material : 32 x 32mmx 1.6t Mild Steel/Stainless Steel SHS Height (H) : 750mm +/- 25mm

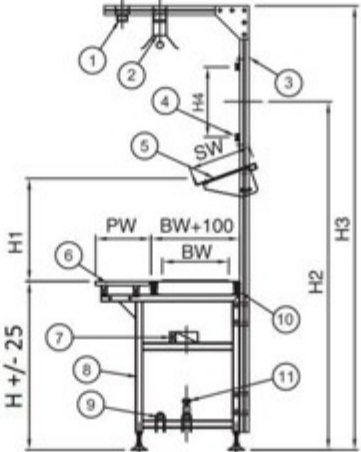
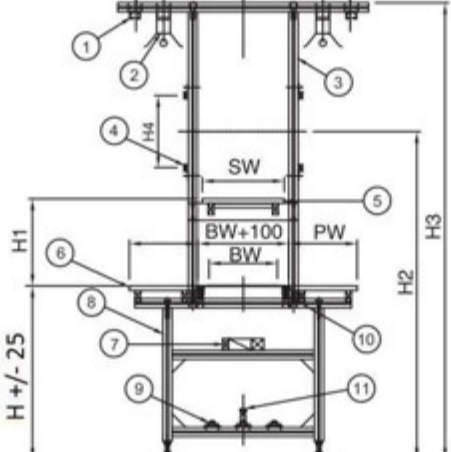
SLS1	SLS2
	
Material : 40 x 40mm Aluminium Profile or 32 x 32mm Mild Steel/Stainless Steel SHS (AL Profile shown) Height Range (H) : 750mm +/- 25mm Accessories: 1. Hanger Rail 2. Fluorescent Light 3. Lighting/Shelving Support 4. AL Instruction Manual Holder 5. Shelving and Support Bracket 6. Plywood Side Table 7. Cable Tray with Socket 8. Support Stand 9. Foot Rest/Bracing 10. 25 x 56mm AL Profile 11. Compressed Air Piping System	

SIDE GUIDES

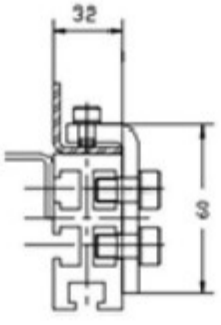
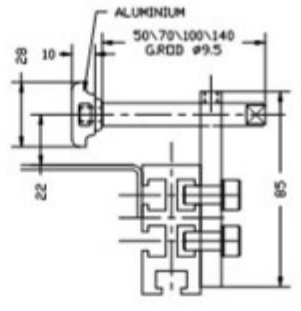
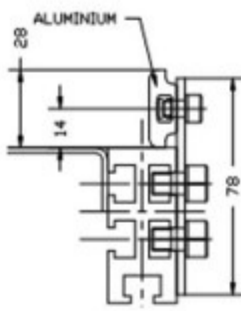
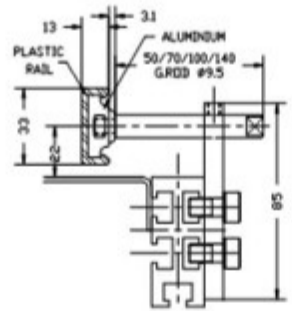
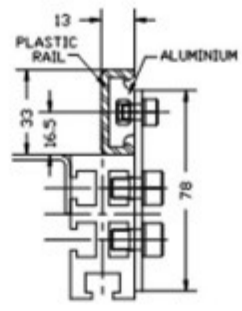
L32B	AG1B	AG5B	PG1B	PG5B
				
Mild Angle Side Guide	Aluminium Profile Side Guide – Adjustable Width	Aluminium Profile Side Guide – Fixed Width	AG1B with Plastic Rail – Adjustable Width	AG5B with Plastic Rail – Fixed Width

Conveyor Model: **APM5**

SUPPORT LEGS

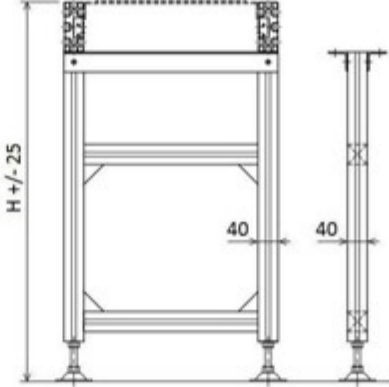
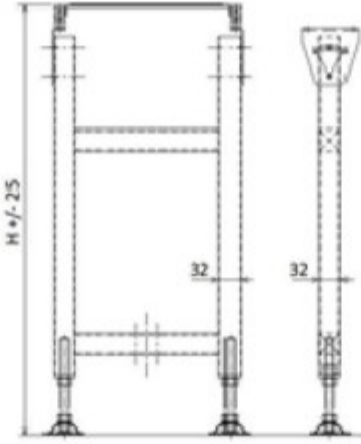
SLH – AL	SLH – MS / SUS
	
Material : 40 x 40mm Aluminium Profile Height (H) : 750mm +/- 25mm	Material : 32 x 32mm x 1.6t Mild Steel/Stainless Steel SHS 1.5t Height (H) : 750mm +/- 25mm

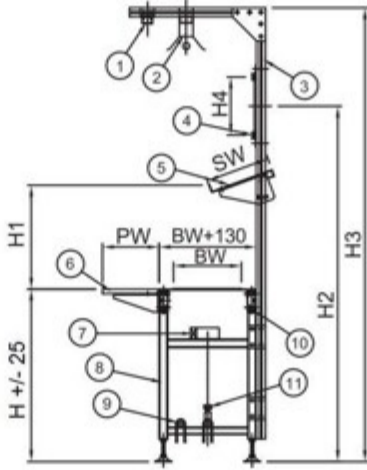
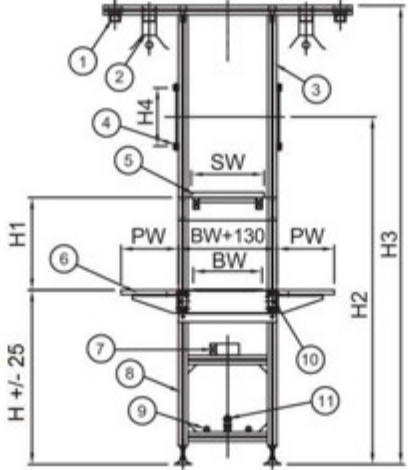
SLS1	SLS2
	
Material : 40 x 40mm Aluminium Profile or 32 x 32mm Mild Steel/Stainless Steel SHS (AL Profile shown) Height Range (H) : 750mm +/- 25mm Accessories: 1. Hanger Rail 2. Fluorescent Light 3. Lighting/Shelving Support 4. AL Instruction Manual Holder 5. Shelving and Support Bracket 6. Plywood Side Table 7. Cable Tray with Socket 8. Support Stand 9. Foot Rest/Bracing 10. 40 x 100mm AL Profile 11. Compressed Air Piping System	

SIDE GUIDES

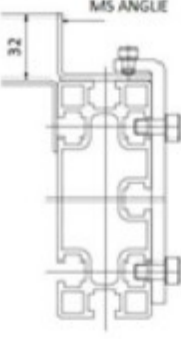
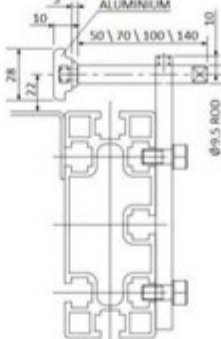
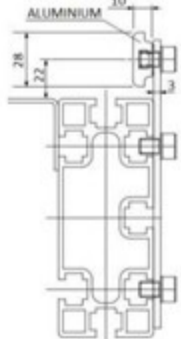
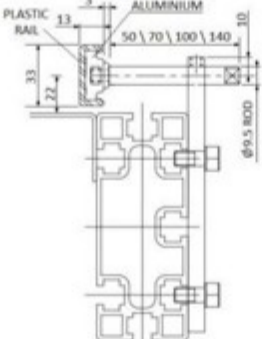
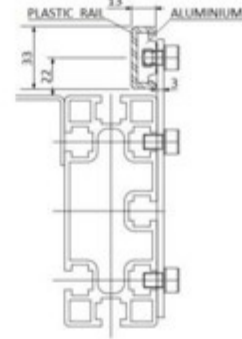
L32A	AG1B	AG5B	PG1B	PG5B
				
Mild Steel Angle Side Guide	Aluminium Profile Side Guide – Adjustable Width	Aluminium Profile Side Guide – Fixed Width	AG1B with Plastic Rail – Adjustable Width	AG5B with Plastic Rail – Fixed Width

