



# COMPACT SERIES SAFE

BURGLAR & FIRE RESISTANCE



MOEM Compact series safe is designed for medium range protection for your valuables and important documents against burglary and fire. Compact series safe is designed for easy operations and everyday use in small businesses, homes and other commercial applications.

## FEATURES

### DOOR & BODY

The overall thickness of door measures 100mm with an effective specially formulated thermo-alloy MT metal-mix barrier material protective thickness of 50mm. The design form an integral part of the door structure strength together with locking mechanism. The overall thickness of body measures 65mm encased with MOEM specially formulated thermo-alloy MT metal-mix barrier material composite.

### BOLT-WORK & LOCKING MECHANISM

Compact series safe is designed with a 3 way running bolt-work locking system. The door is further secured by full vertical interlocking system. Bolt measures 25mm in diameter.

Compact series safe comes complete with 3 wheel keyless combination lock (1,000,000 combination variation) and a key lock. Other locking options such as digital lock available as accessories. (optional).

### INTERNAL FITTINGS

Compact series safe comes complete with one adjustable steel

shelf. Model MS200, MS300 and MS300T comes complete with a lockable internal bottom drawer.

### FIRE RESISTANCE

Safe is tested for 30 minutes in accordance to JIS 1037:1989 (Japanese Industrial Standard).  
[\*refer test report]

**Door Protective Thickness 50mm**

**Body Protective Thickness 65mm**

**Thermo-Alloy MT Metal-Mix Barrier Material**

**3-Way Running Bolt**

**Internal Fittings**

**Fire Resistance**

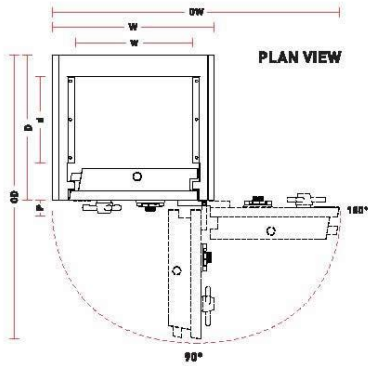

MODEL	EXTERNAL (mm and Inches)				DOOR @90°	DOOR @180°	INTERNAL (mm)				WEIGHT
	(H)	(W)	(D)	(D+P)	(OD)	(OW)	(h)	(had)	(w)	(d)	
MS100	385 [16.2"]	533 [21"]	457 [18"]	502	920	970	245	—	393	270	170
MS200	584 [23"]	508 [20"]	533 [21"]	578	985	925	445	318	348	340	250
MS300	685 [27"]	508 [20"]	533 [21"]	578	985	925	545	420	348	340	285
MS100T	508 [20"]	533 [21"]	457 [18"]	502	920	970	245	200	393	270	210
MS300T	813 [32.1"]	508 [20"]	533 [21"]	578	985	925	545	395	348	340	330

EXTERNAL: (H) — HEIGHT / (W) — WIDTH / (D) — DEPTH / (D+P) — OVERALL DEPTH  
INTERNAL: (h) — height / (w) — width / (d) — depth / (had) — height above drawer



**MS100T & MS300T (DRAWER TRAP SYSTEM)**

Drawer trap system allows deposit of cash and documents without having to open the main safe door. System is fitted with an anti-fishing plate to deter fishing of content from the safe. Drawer trap is also lockable. These features are ideally suited for retailers i.e kiosks, gasoline stations, restaurants, mini-marts and others where there is turnover of employee shifts and cash turnover.

**ACCESSORIES**

Digital lock / Envelope slot / \*Other special fittings  
Standard colour: Light Grey

- \* Safe comes complete with 1 adjustable shelf
- \* MS200, MS300 & MS300T come complete with internal drawer
- \* Ensure door able to open 180° to maximize usage & drawer usage
- \* Recommended to allow 25mm gap on each side internal height MS100T & MS300T is measured up to anti-fishing plate
- \* D+P—Overall depth + handle
- \* OD—Overall depth door @90°
- \* OW—Overall width door @180°
- \* Had—Height above drawer \*except MS100T
- \* Floor bolting to be specified before manufacturing
- \* Measurement in inches ["] as guide
- \* Weight ±10%

