



Box&Display

POP DISPLAY AND BOX DESIGN, POWERED BY FLEXI

Getting Started & Tutorial

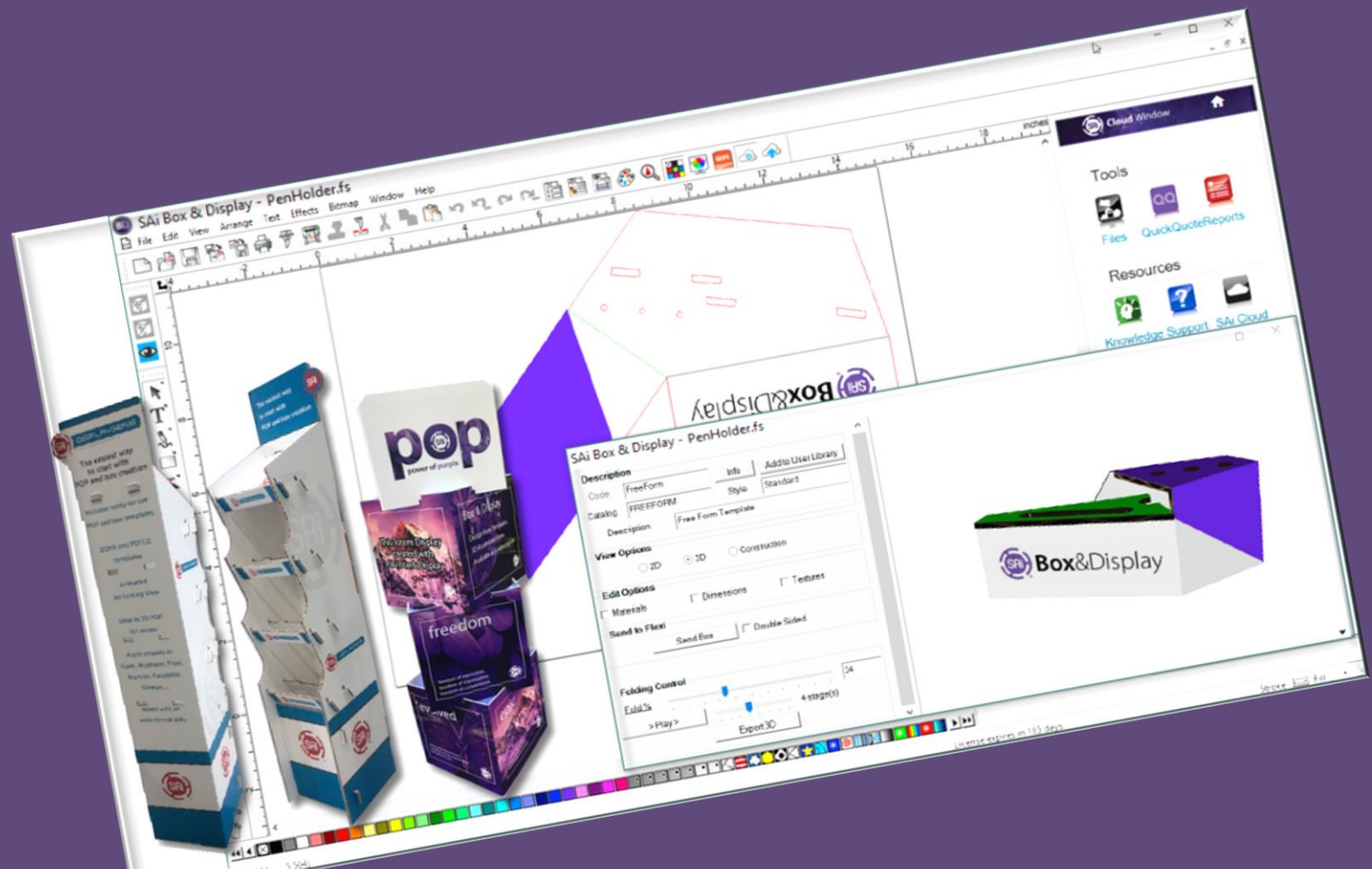

Table of Contents

SAi Box&Display powered by Flexi	8
Overview	8
What it does and how it works	9
Extensive library of easy-to-adjust POP-display and box templates	9
Flexi and Box&Display - Basic Elements	10
The Box&Display Interface	10
Specifications	10
Chapter 1: Template - Create a Box/Display	11
Create a Box/Display from a Template with No Graphics	11
Floor and Shelf Displays	12
DXF Cutouts Displays	12
Adding New Machining Steps to a Created Box	13
Flip Ups	14
Adding Graphics to a Box/Display once it has been created	15
Box Wizard	16
Flap Closure Style and Options	17
Add to User Library	19
Chapter 2: Template Library and User Interface	20
Templates	20
Catalog	20
Library	20
User Interface	21
Property Inspector	21
Friendly Page Controls	21
Preview Pane	21
Active Section	21
Chapter 3: Template - Friendly Page Controls	24
Properties	24
Add to User Library	24
View Options	24
3D View	25
Folding Control	25
3D Export	25
3D Assemble	26
Edit Options	26
Materials	26
Dimensions	27
Panels	28
Panels and Slots	29
Standard Flaps	29
Glue Flaps	30
Textures	30
Annotation Settings	30
Texturing Modes	31
Chapter 4: Formula Controlled Sections/Flaps	32
Error Indicator	32
"Import section reference. Convert to local copy?"	32
"Formula-controlled section. Eliminate formulas?"	33
Lock / Unlock	33
Consequences	33
Stretch Mode and Scaling	34

Table of Contents

Chapter 5: Context Menus, Commands and Actions	35
Active Section - Main Context Menu.....	35
Fly Out Menus	35
At Section options.....	35
Add Machine Step options.....	36
Point, Line or Machine Step – Main Context Menu	36
Fly Out Menus	36
At Point options	36
At Line options	37
At Machine Step options.....	37
Stretch Mode options	37
Hotkeys.....	38
Repeatable commands:.....	38
Mouse Actions.....	38
Construction Preview.....	38
3D Preview	39
Construction View Navigation:.....	39
Chapter 6: FreeForm Construction Preview Interface	40
Notes on Active Section	41
Notes on Active Point.....	42
Chapter 7: FreeForm - Create New Box/Display	44
Base Line Width.....	45
Add New Section	45
3D Preview	46
Add a Lid.....	46
Illustrate Box with Flexi	47
Chapter 8 Freeform Capabilities	49
Sections	49
Machine Steps.....	50
Machine Step Points.....	51
Machine Step Lines	52
Modal Cursors	52
Modal Command Procedures.....	53
Adjust Section Height	53
Add Machine Step	54
Drag Point	54
Add Points Before, Add Points After	54
Attach Hinge to Point	55
Curve Line.....	55
Chamfer corner, Fillet corner	55
Split Machine Step	55
Add Tab or Notch	56
Add Slot	56
Add Circle or Oval Slot.....	56
Tutorial Videos	57
FreeForm Tutorial 101 – Create New Box	59
Adding More Panels	60
Adding Lid Flap to Main Panel.....	60
Adding Tuck Flap to Lid Flap.....	61
Fillet Flap Corners.....	61
Create Dust flap.....	62
Adding a Glue Flap and Chamfer Corner.....	62

Table of Contents

FreeForm Tutorial 102 – Fold Sequence	64
Setting the Stages Slider.....	64
Setting the Fold Sequence.....	64
Illustrate Box with Flexi.....	65
View in SAi Box Display.....	65
Fold and Position Illustrated Box.....	66
Preview Pane Focus and Navigation.....	66
FreeForm Tutorial 103 - Add Flaps and Glue tabs	68
Add Glue tab – Section Height dialog.....	68
Change Active Point Length.....	68
Notes on Alignment and Snap to Grid.....	69
Copy Section to Clipboard and Paste.....	69
Add Flaps and Chamfer.....	70
Fold Sequence.....	70
Folding Control.....	71
FreeForm Tutorial 104 - Simple Scale & Stretch Modes	72
Scale Height with Width.....	72
Change stretch properties of points.....	72
Enlarge Box.....	73
FreeForm Tutorial 105 – Parametric Scaling	74
Dimension More button.....	74
Connect Values to Formulas.....	75
Apply Formula to Sections.....	75
Proportional Stretch Mode to Chamfer.....	76
Proportional Stretch Mode to Tab.....	76
Proportional Stretch Mode to Rivet.....	77
Proportional to Base Line.....	77
Add to User Library.....	77
FreeForm Tutorial 106 – Making Custom Flaps	78
Add Basic Flap.....	78
Notes on Machine Steps.....	78
Notes on Open/Close Machine Step.....	79
Notes on Hide/Unhide Machine Step.....	79
Notes on Coordinates.....	79
Drag Point.....	80
Add Point After.....	80
Mirror Complete Machine Step.....	81
Curve Line.....	81
FreeForm Tutorial 107 – Repeating Commands	82
Add Basic Flap.....	83
Fillet Corner (rounded).....	83
Resize Flap.....	83
Non-Orthogonal Direction.....	84
Fillet with Two Arcs.....	84

Table of Contents

FreeForm Tutorial 108 – Curves and Fillets	85
Snap to Grid.....	85
Add Base Line for tab – Add Points After	85
Curve Line.....	86
Curve tab and Change Radius.....	86
Add Fillet Corner (rounded)	86
Tangent to Prev / Next	87
Notes on Section Boundaries.....	87
Fillet with Two Arcs	88
Adjust Two Arc Corner	88
Add Machine Step / Hole	88
Radius Greater than Base Line	89
FreeForm Tutorial 109 – Import Predesigned Flaps	90
Create Basic Flaps.....	90
Clipboard & Imports.....	90
Add Import Section Reference	90
Edit Import	91
Resize Parent Section	91
Convert to Standard Construction View	92
Make Changes to Slot.....	92
Construction View.....	93
Lock / Unlock.....	93
Imported Sections	93
FreeForm Tutorial 110 – Dimensions with Annotations	94
Dimension	94
Format Machine Step - Dimension.....	95
Notes on Dimension Formatting.....	95
Dimension Multiple Lines.....	96
Dimension Formatting and Align to Axis.....	96
Point Position X,Y	97
Add Label Arrow.....	97
Label Arrow Formatting	97
Notes on Annotations.....	98
FreeForm Tutorial 111 – Making a Flip Up	99
Perforation Machine Step	100
Convert to Flip Up	100
FreeForm Tutorial 112 – Rivet Holes	101
Add Rivet Hole to Flap 6.....	102
Copy Flap with Rivet.....	103
Mirror-reverse Machine Step.....	103
Edit Offset.....	104
Copy the Offset Flaps	104
Offset Flap_2 and Flap_3	104
Add Rivet Holes to Flap 1	105
Add Basic Flap to Flap_4	105
Chamfer Corner.....	105
Offset tabs.....	105
Fillet Corner (rounded).....	106

Table of Contents

FreeForm Tutorial 113 – Add Tab, Notch or Slot	107
Split Machine Step	107
Add Tab or Notch	108
Add Slot	109
Add Circle or Oval Slot.....	110
Deleting Tabs, Notches or Slots.....	110
Pen Holder Display	110
Template Tutorial 200 – Create Box FEFCO 0205.....	112
Start by opening a template.....	112
Construction View	112
Select Active Section	112
No Entry message.....	113
Add Basic Flap – 8mm Glue tab.....	113
Repeat Command.....	114
Add Machine Step - Dimension.....	114
Format Machine Step.....	115
Send to Flexi	115
Template Tutorial 201 – Shelves / X017 Clinton FSU.....	116
Unit Style.....	116
Back Settings	117
Chamfer & Radius Top Front corner	117
Shelf Settings.....	118
Toekick Settings.....	118
Support Rod Holes.....	118
Sample Cutting Layouts.....	119
Template Tutorial 202 – Toolpath and Fold Lines	120
Machine Filters.....	120
Note on Machining Options.....	120
Fold Allowance	121
Material Thickness and Panel Recess.....	121
Pattern for Panel Recess	121
Template Tutorial 203 – Sloped Shelf Displays.....	122
Display & Product Parameters	122
Header and Skirt Heights.....	123
Header Radius	123
Header Pop Out.....	123
Header Pop Out Radius	124
Shelf Parameters	124
Assemble Unit	125
Package Parameters.....	125
Space or Gap	125
Template Tutorial 204 - DXF Cutouts.....	126
Swan Basket Display.....	126
DXF Shapes and Flip	128
Rocking Horse Display	128
ClipArt Imported to Flexi.....	128
Customize ClipArt for Cutout	129

Table of Contents

Template Tutorial 205 – Countertop Box and Flip Up	131
Import Clipart	131
Perforation Machine Step	132
Curve Line	133
Convert to Flip Up	133
Fold	133
Template Tutorial 206 – Furniture Modern Shelf	134
Template Tutorial 207 – Furniture & Stands	136
Furniture	136
Floor Stands	136
Template Tutorial 208 – Box Inserts.....	137
Edit Insert	137
Add Lid and Gap Controls.....	138

SAi Box&Display powered by Flexi

Overview

SAi Box&Display eliminates multiple steps to improve job creation efficiencies and simplify the structural design of folding carton, corrugated plastic and rigid honeycomb material POP and free-standing display units, as well as packaging.

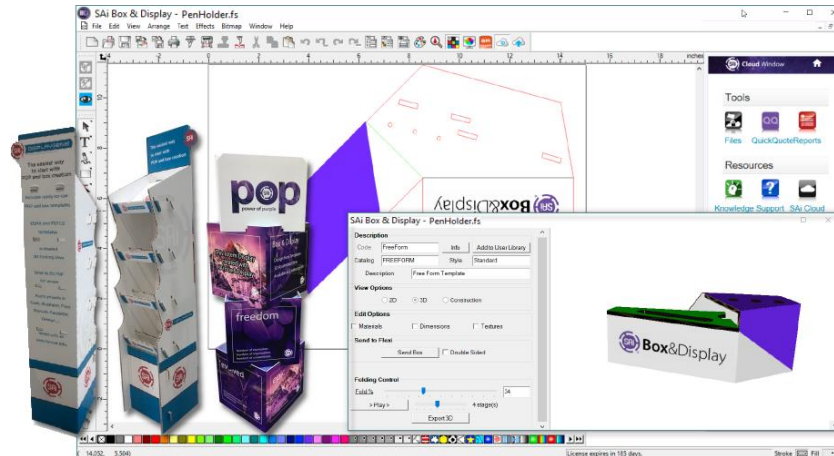

SAi Box&Display is compatible with all existing wide-format RIP software that drives flatbed printers and cutters and features a simple, yet complete toolset to enable easier display and box structure design. Powered by the company's renowned Flexi software, SAi Box&Display features an extensive library of continually-expanding display and box templates. This allows print providers to quickly choose and personalize these to meet their client's exact specification. Using SAi Box&Display's intuitive interface, designers can enter new geometric values, from which the SAi Box&Display software then parametrically rebuilds designs in seconds.

Further cost- and time-saving benefits are provided by an integrated graphic and structural design with animated 3D folding preview, which helps maintain workflow efficiency by catching any mistakes before production. This is also aided by the ability to export rotational package display or box designs as 3D PDF files, for customer review prior to production. As a result, SAi Box&Display overcomes the troublesome pain-points faced by designers when creating such pieces in their existing third-party software.

Help Documentation **Flexi** is the CAD platform on which all of the shapes are created and **SAi Box&Display [BD]** is the 3D Parametric Design and Rendering Engine that allows for templates to be used and manipulated. SAi Box&Display works in conjunction with Flexi to create the related contours on screen after which the files are created and saved. The saved files include both Flexi and SAi Box&Display data that allows the file to be converted into a template at any time by opening it in BD.

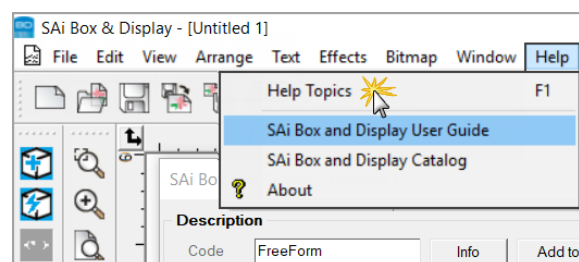

Since Box&Display works in conjunction with Flexi to create the related contours on screen, there is separate documentation available. To learn about the drawing and design tools of Flexi, read the **Flexi Help Topics [F1]**

This manual, **SAi Box and Display User Guide**, will help you to learn about Box&Display. BD allows you to use existing templates which you can easily modify to your requirements. So, the first topic addressed in this manual is how to do this.

What it does and how it works

SAi Box&Display is a 3D design software package for boxes and POS displays. It is based on pre-defined templates and is mainly intended for production on large-format inkjet printers and digital cutting tables.

SAi is a US-based software developer, specialising in RIPs and related production software for large-format printers and CNC routers. SAi Box&Display includes components from SAi's Flexi signage design software, which allows artwork to be added to box and display item templates.

SAi Box&Display is efficient because its all-in-one structure eliminates multiple steps. It can quickly create and apply artwork to the structural design of folding carton, corrugated cardboard and sandwich material POS for free-standing display units.

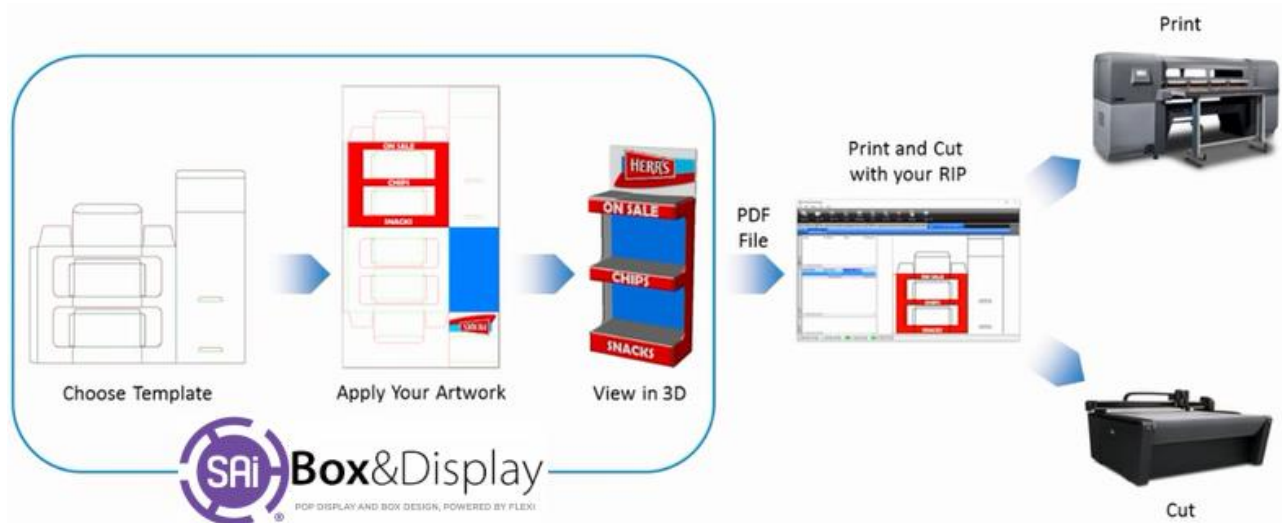

Extensive library of easy-to-adjust POP-display and box templates

SAi Box&Display allows for the creation of digital flat artwork onto items from a library of pre-defined folding carton, POS and display templates.

Since the design of a functional package or POS is quite intensive, it is recommended using and modifying existing templates. Users can, however, create their own templates if a user has the inclination, as the tool is quite powerful and can be used to create virtually any type of package or POS display.

The "hundreds" of box and display templates supplied include items from ECMA (European Carton Makers Association) and FEFCO (the European Federation of Corrugated Board Manufacturers). Templates include multiple pieces where relevant, with tools to add features such as Design features include vector and bitmap tools and include effects such as shadows and gradients, and for the creation of masks, outlines, etc. White, varnish and metallic channels are supported and variable text can be specified. Objects can also be nested for efficient layout on the printer.

The templates align to 3D CAD models so designs can be applied to these and previewed in 3D. Integrated graphic and structural design, with animated 3D folding preview, helps maintain workflow efficiency by catching any mistakes before production. 3D files can also be exported as PDFs that can be sent to customers for approval.

After approval, the files can be sent to any RIP, not just SAi's. There are no drivers or hardware-specific features needed.

Flexi and Box&Display - Basic Elements

The illustration below shows some of the basic elements of your software. Note that the **Box&Display icons** may vary in position to the image below, position of which can be change to suit user preference.

Flexi* is the CAD platform on which all of the shapes are created and works in conjunction with **Box&Display** which is the 3D Parametric Design and Rendering Engine that allows for templates to be used and manipulated.

* For more details on how to use Flexi, see the Help Topics available from Main Menu or F1.

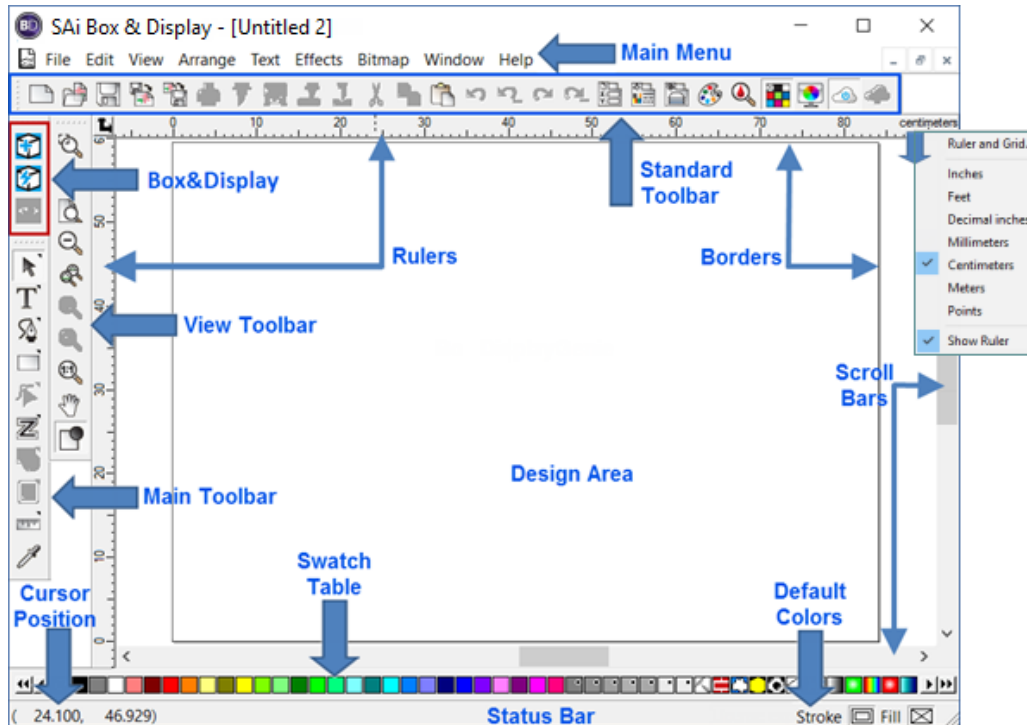

The Box&Display Interface

To access the Box&Display interface you need to start a new Box and Display project.



From the Flexi toolbar, you have two choices.

- (1) Start a 'New' Free Form design from scratch
Discussed in [Chapter 6](#) and [Chapter 7](#)

or

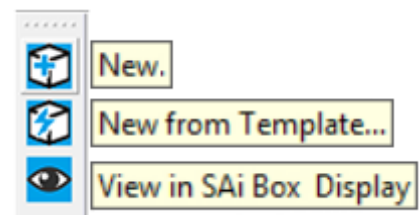
- (2) Start a new design from a template.
Discussed in Chapter 1



The **View**  button is used to Open/View a box you have created. If the other two icons shown are greyed out as a result, the Ctrl+N [ or File>New] will present these again for selection.

Specifications

Platform	PC running Windows 7 to 10 (16 or 32-bit)
Input file formats	Include PDF, AI, EPS, JPEG, TIFF and PNG
PDF Viewer	Free Adobe Acrobat Viewer required for Export 3D
Design tools	Include raster and vector elements, with support for white, clear and metallic channels
Output file formats	Include PDF, AI, PSD, JPG and TIFF
Compatibility	Works with any printer RIP or cutting software.

Chapter 1: Template - Create a Box/Display

The most efficient way to create a new box or display is to start from an existing template and this section will discuss the basics on how to do this. [Tutorials](#) are provided later in this manual.

On the Flexi toolbar, clicking on the **lightning bolt**  button will allow you to **use existing templates** which can quickly and easily be modified to meet your requirements.

Watch the short video to get a quick overview of what will be discussed in this chapter.

 [How to Create a Corrugated POP Display in Seconds Using Box and Display](#)

NB: Internal hyperlinks have been added to allow you to locate more detailed instructions on a topic.

Just use the following shortcut commands ...

- **Ctrl+Click** to **follow internal link** to quickly navigate to other parts of this document.
- **Return** from a hyperlink jump by using **Alt+left-arrow**  **Acrobat Reader** required for this option.

Create a Box/Display from a Template with No Graphics

Here is the process for creating a new box from a template using just the [Friendly Page](#) controls:

Tutorial Video  [Starting New Project](#)

1. Open a new Box&Display file by clicking on the **lightning bolt**  button.
2. Use [Catalog](#) to identify the box to be cut.
3. Select the Standard [Library](#) to display the list of Box&Display templates.
 - Double click the desired Template from the Box Library **or** click, to select, and click 'Create'.

Suggestion: Select a FEFCO 0205 which is a simple box – See [Tutorial 200](#) Step 1

NB: [Box Wizard](#) is available for selection here and will be discussed at the end of this chapter.

4. A dialog box, called a [Property Inspector](#), is displayed for the selected template. Shown is the related [Friendly Page](#).

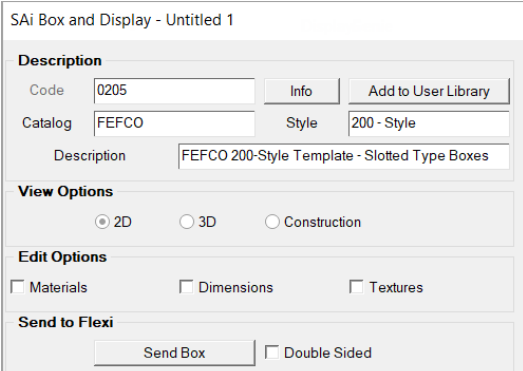

The screenshot shows a dialog box titled "SAI Box and Display - Untitled 1". It has several sections: "Description" with fields for Code (0205), Catalog (FEFCO), and Style (200 - Style), and a description field containing "FEFCO 200-Style Template - Slotted Type Boxes". There are "Info" and "Add to User Library" buttons. The "View Options" section has radio buttons for 2D (selected), 3D, and Construction. The "Edit Options" section has checkboxes for Materials, Dimensions, and Textures. The "Send to Flexi" section has a "Send Box" button and a "Double Sided" checkbox.

5. Radio buttons for [View Options](#) allow you to select how your template is displayed. Default is **2D**.

Edit Options can be used to make required adjustments.

6. Click [Materials](#) .
 - Enter your Material Thickness
 - Make any other necessary material variable adjustments.
7. Click [Dimensions](#) .
 - Use the provided entry boxes to set the primary box dimensions for the box that is being created.
8. [Flaps, slots and tabs](#) can be adjusted as required.
9. Now click the [3D View](#) and a 'Play' button will be displayed
 - Click 'Play' to simulate the folding of the box ensure that the box fits together properly.
 - A [3D PDF](#) of the finished box can be created using this utility.

10. Click [Send to Flexi](#) – the box will now appear as contours in flexi.
 - There are different colors, which represent different layers/cut operations.
 - ❖ Green lines are fold lines – See [Tutorial 202 Toolpath and Fold Lines](#)
 - ❖ Red lines are cut lines.
11. With no graphics being added, the file is ready for export to PDF or DXF.
 - Click **File > Export** and export the file, making sure to specify the desired file export format.
 - ❖ These files can be brought into whatever solution is used to output files to the CNC cutter, be that a CAD/CAM software or directly to the machine controller, depending on the machine.

FLEXI CUSTOMERS

If you have SAI Flexi Software, you can use Production Manager from your Flexi to send the cut files to your CNC cutting device.

Another option is to **File > Save** in Box&Display as an **FS** file, and then open the saved file into Flexi for sending to the cutter.

ENROUTE CUSTOMERS

If SAI EnRoute software is being used to drive your CNC cutting machine, you can use the **DXF** file format to bring the Box&Display files into EnRoute.

Another option is to use the **Send to EnRoute** icon to send the files to EnRoute if both programs, EnRoute and Box&Display, are located on the same machine.

Floor and Shelf Displays

In Box&Display there are many variations available and the following tutorials discuss other options and settings which are relevant to specific templates...

- [Tutorial 201 Shelves - X017 Clinton FSU](#)
This Floor Stand Unit tutorial looks at ability to configure settings such as size, number of shelves, support rods and some additional style options.
- [Tutorial 203 Shelves - Sloped Shelf Displays](#)
- [Tutorial 206 Furniture - Modern Shelf Unit](#)
- [Tutorial 207 Furniture and Stands](#) which discusses the X062 Dillion Table

DXF Cutouts Displays

A DXF file is a file format understood by many graphical packages and is generated to send to your machining software.

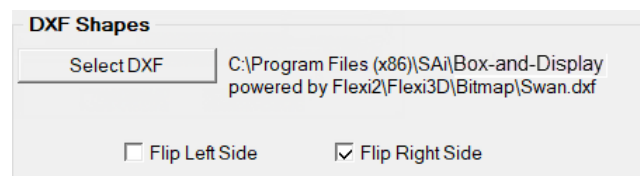

- [Tutorial 204](#) discusses how to use supplied DXF files (e.g. Swan.dxf) and how to create your own.
- [Tutorial 207](#) discusses supplied DXF's to create Floor stands.
- [Tutorial 208](#) discusses use of DXF's with box inserts. Available FEFCO 0300 to 0308, 0331, 0427

Adding New Machining Steps to a Created Box

We will now use the box you created above to add Machine Steps.

- Open/View the box you created above by clicking on the **View**  button.
- Ensure that you are in [Construction View](#)
- We will be working directly in the [Preview pane](#) on the right of the Friendly controls.
- Select a section of the box that you want to work on by double clicking on it. This will make the section **Active** – note the section will be highlighted in light blue.

Suggestion: Select **Sec3_P_Panel** as shown.

- Left click on machine line shown by the cursor  and right click to display the [context menu](#).

Then click required action or used shortcut keys shown on RHS of menu e.g. **N**

Machine lines are ...

- shown in **red**.
- when selected, it changes to display an arrow . See [Notes on Machine Step](#).
- Note that templates will almost always have [formulla controlled sections/flaps](#) and you will notice a **No Entry** sign as above. However, this should not be an issue in this discussion.
- From the context menu select [Add Machine Step > Hole](#) [To use Shortcut Keys: Right Click presents context menu, then hit **N** on keyboard [Add Machine Step] and then **H** for Hole

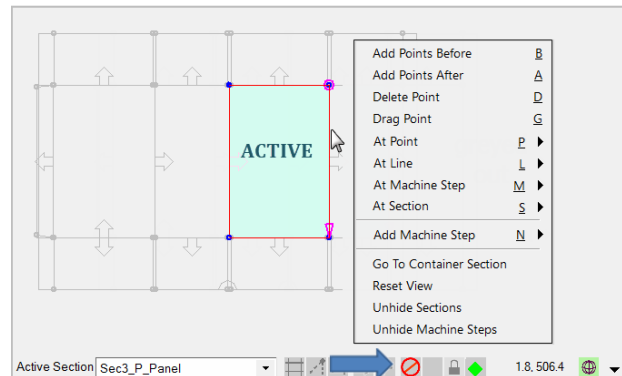

We will add a square hole. [See [Tutorial 108 – Step 10](#) on how to make other shapes.]

- Left click at required intervals, as shown below points 1-5, to form a square.

Tips

- Use [Mouse Actions](#) to **Zoom In** for a better view
- Turn on **Snap to Grid** by left clicking on  icon located on the Status Bar– see [Tutorial 103 – Step 3](#) endnotes
 - Adjust the Grid Spacing by opening dialog i.e. right click on icon.
- To constrain the line to last point and keep straight –
 - **Hold down** the 'shift' key while creating the square.

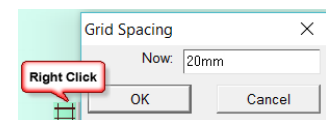

The **3D View** shows the result.

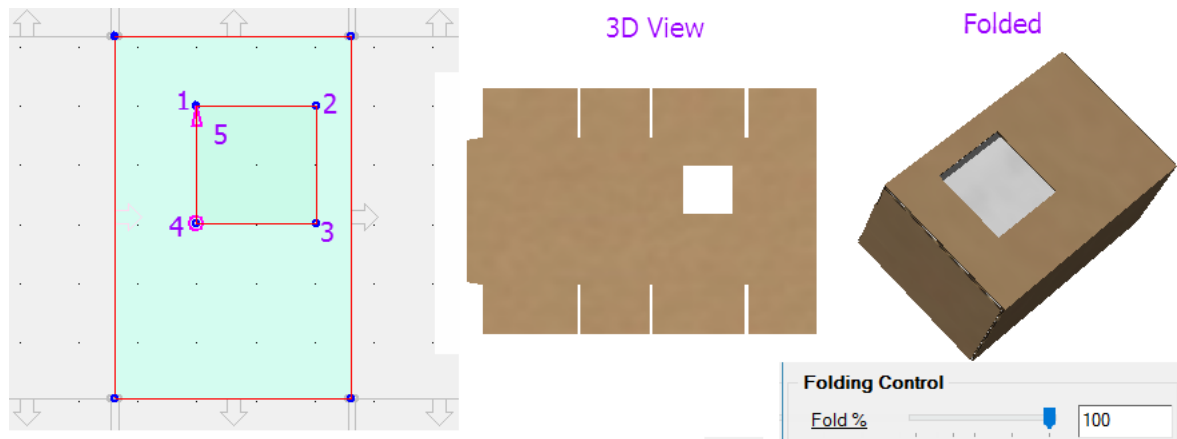

Note: If you need to make adjustments to the hole e.g. line not correctly placed, you cannot simply 'Drag Point' to correct. Once a step is added, unfortunately it does not check which bits of the section you are dragging, so any attempt to drag a vertex will require *removing all formulas* and making the section Construction View compatible – See [Chapter 4 – Formula Controlled Section](#).

Two alternatives are (1) Undo, undo, undo.... then add hole again more carefully or

(2) Delete hole [**At Machine Step > Delete Machine Step**] then add again.

Flip Ups

Flip ups are a common feature of point of sale boxes.

This is a typical flip up here with a piece cut out of an adjacent section which doesn't fold down but remains pointing up.

Flip Ups are made with

- 1) a perforation machine step

Add Machine Step N > Perforation

- 2) and then converting the perforated part into a flip up

At Machine Step M > Convert to Flip-up

See [Tutorial 205](#) for instructions on how to achieve this.

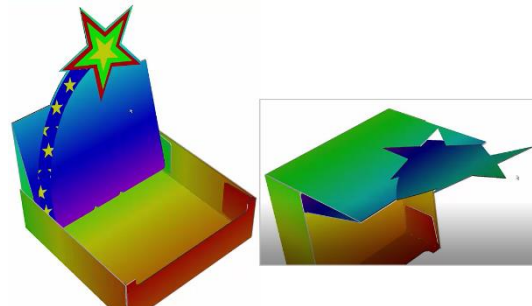

Adding Graphics to a Box/Display once it has been created

Now we will illustrate the box. To do this we need to give Flexi the cutting instructions, which is a DXF in 2D line view with cutting and creasing instructions.

Tutorial Video  [Send to Flexi](#)

1. **Send to Flexi** by clicking [Send Box](#).

Close the BD Property Inspector, using the top right **X**.

2. We will now **Import** artwork for use in illustrating our box.

3. Using the  icon on the Standard Toolbar, locate your artwork and **Import** as shown.



4. Place artwork as required, e.g. →

5. Then click on the eye  icon to **View in SAI Box Display**

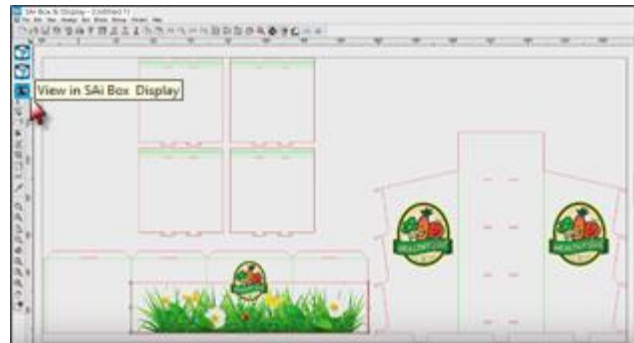

6. You will see the resulting placement of artwork using the [3D View](#) Option.

7. You can now send a PDF to your customer for approval by using the [Export 3D](#) button.

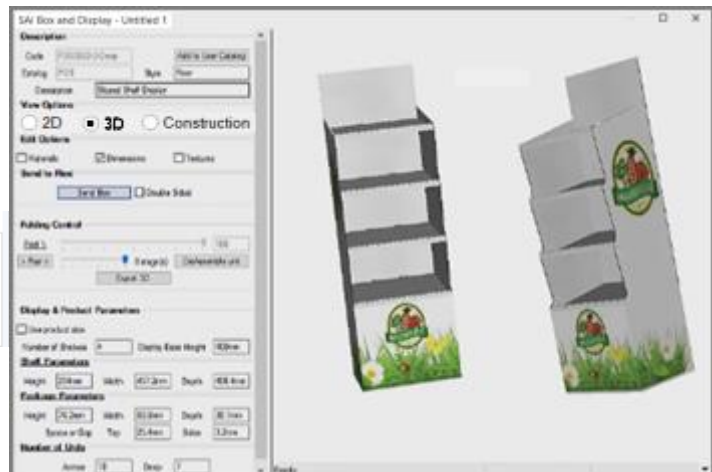
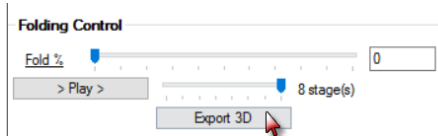

8. The resulting PDF produced can be saved in the normal way.

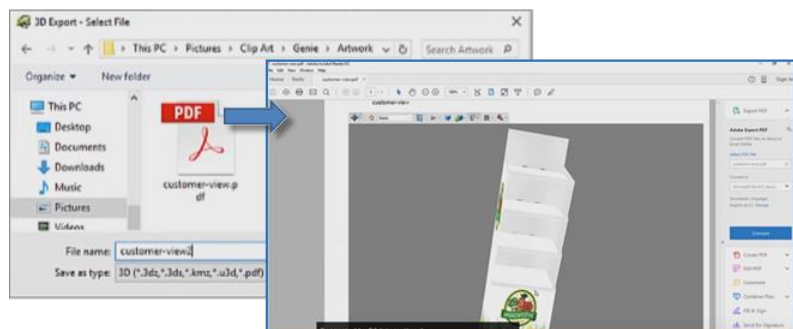

Box Wizard

Box wizard is the perfect tool for quickly designing one off and small runs of boxes and shipping cartons. It is fast and easy to use with a very intuitive interface.

Use the **lightning bolt**  button to view template catalog and you will notice that BOX-WIZARDS is available with a starting template **Box_01** which can be used to create your box and when you are finished, you can save it to your user library with your own naming convention.

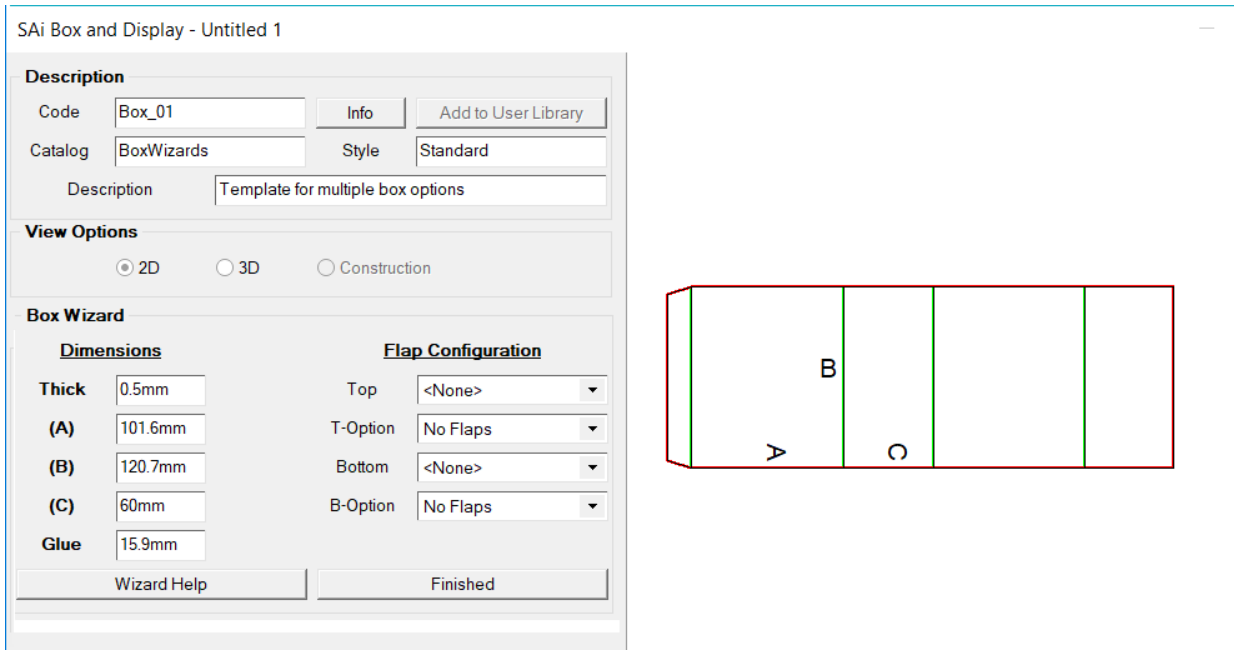
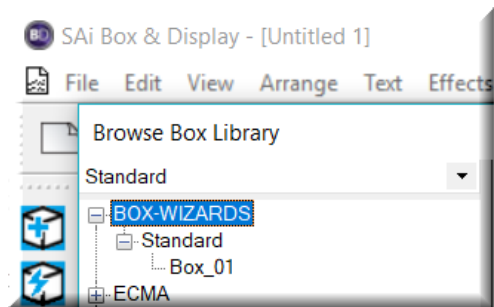

Description

Optional and is typically used when you plan to save a finished box to your user library. NB: You can only [save a box to the user library](#) after you have pressed the **Finished** button.

View Options

2D (default) and **3D** View, initially, are only available. The 3D view is great for looking at the finished product and to see how it is folding. **Construction** View is available after clicking the Finished button.

Box Construction

The box offered in the wizard is a simple four panel construction to create the sides with or without added closure flaps. The Glue flap is glued to the inside or outside of the last panel to form a four-sided tube. Box dimension are really straight forward.

Dimensions		
Thick	0.5mm	Thick = The thickness of your material
(A)	101.6mm	(A) = The width of the box
(B)	120.7mm	(B) = The height of the box
(C)	60mm	(C) = The depth of the box
Glue	15.9mm	Glue = The width of the Glue flap

Flap Configuration

Use the Flap Configuration dropdowns to select the **Style** and **Options** for the closure flaps.

And finally press the **Finished** button to finalize your box.

Your box is ready to go without any further work but if you should choose to do further edits you can open the advanced properties of your box after you have pressed the Finished button.

Flap Configuration



Top ▼ Tab-Closure

T-Option ▼ Option 01

Bottom ▼ Tuck-in Style02

B-Option ▼ Default

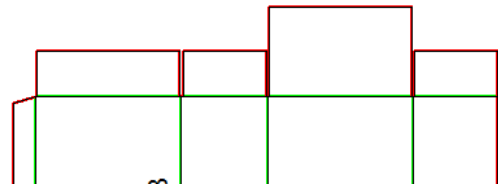
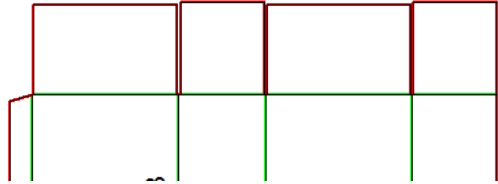
Flap Closure Style and Options

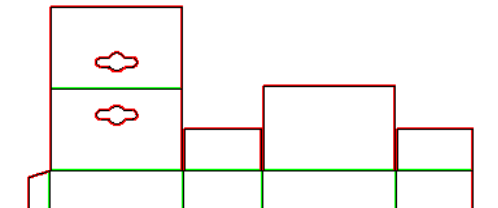
<p style="text-align: center;"><None> - No Flaps</p> <p>Used when the box is open on the top or bottom with no closure flaps</p>	
<p style="text-align: center;">Standard – Default</p> <p>Used as a glue type closure where the main wide flap is closed over the top of the other flaps</p>	
<p style="text-align: center;">Standard – Overlap</p> <p>All flaps are folded over each other</p>	
<p style="text-align: center;">Standard – Reduced Flaps</p> <p>This is the type most often used for standard shipping cartons that are usually glued or taped shut</p>	
<p style="text-align: center;">Standard – Hanging</p> <p>This type is commonly used for small items that can be hung on peg shelving The top main flap is glued shut.</p>	

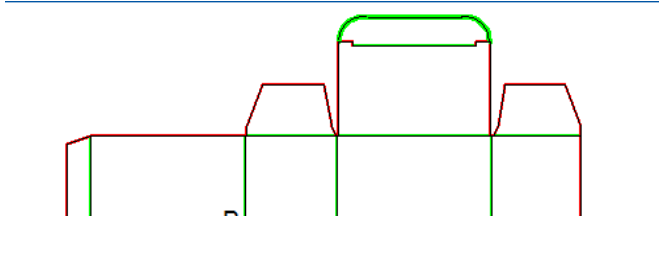
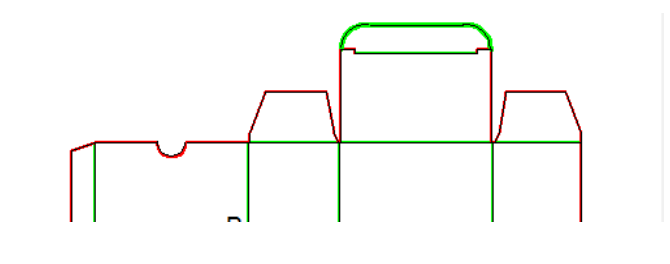
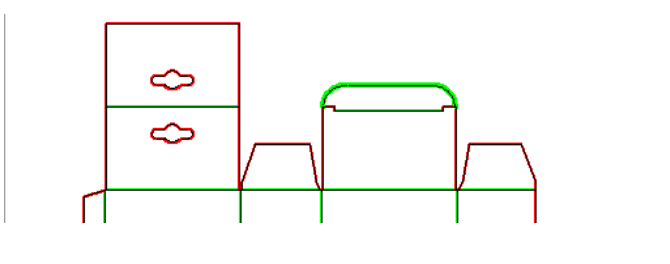
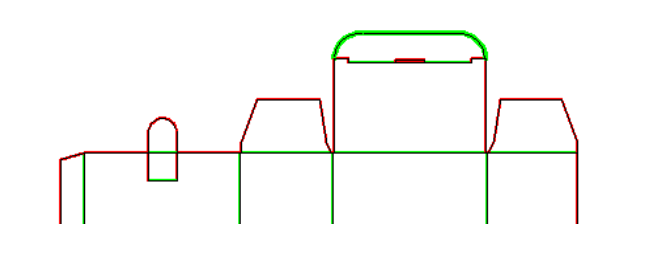
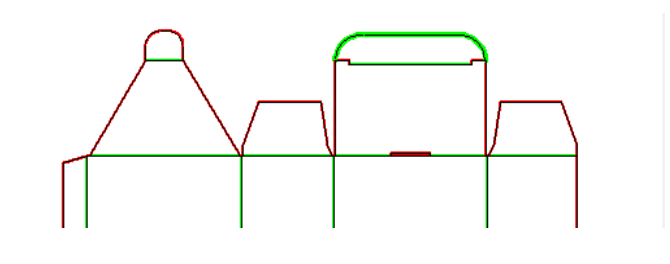
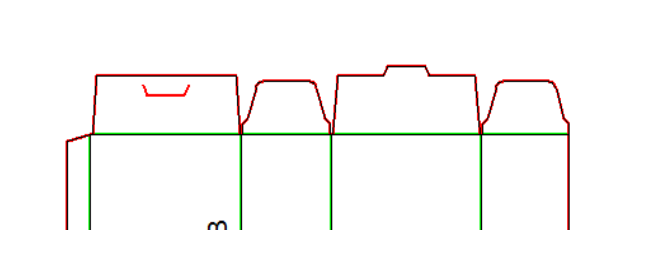
<p>Tuck-in Style 01 and 02 – Default Used for boxes that can be opened and closed for reuse</p>	
<p>Tuck-in Style 01 and 02 – Thumb Cutout Used for boxes that can be opened and closed for reuse with thumb cutout</p>	
<p>Tuck-in Style 01 and 02 – Hanging Used for boxes that can be opened and closed for reuse with Hanging flap</p>	
<p>Tuck-in Style 01 and 02 – Tab Lock Used for boxes that can be opened and closed for reuse with Tab Lock</p>	
<p>Tuck-in Style 01 and 02 – Double Lock Used for boxes that can be opened and closed for reuse with a Fold Over Lock (Top flaps only)</p>	
<p>Tab-Closure – Option 01 and 02 Used commonly for food item cartons such a cereal box for re-closure after breaking the glue seal (Top flaps only)</p>	

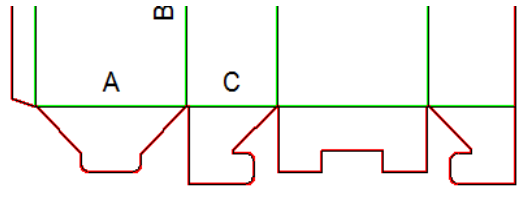
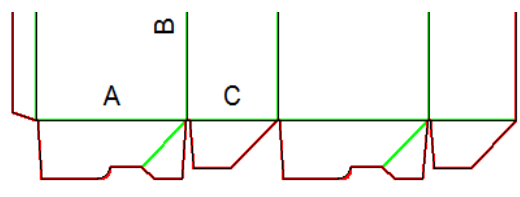
<p>Tongue Lock – Default Interlocking flap system, easily disassembled (Bottom flaps only)</p>	
<p>Crash Lock – Default Pre-glued integrated system used for flap pack shipping of assembled boxes (Bottom flaps only)</p>	

Add to User Library

Use the **Add to User Library** button to save a modified box for future use.

Before clicking on ‘Add to User Library’, you can make changes to the **Description**, or not, as required. In this example Box_01 has been changed to **Box_New** but the Catalog and Style has been left as is.

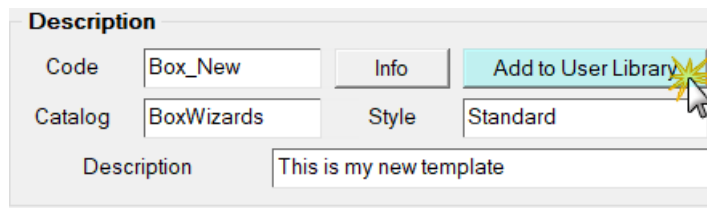

A warning message will remind you that only the current state of your box design will be saved in the catalog for future use as a template. To proceed to add to User Library, click ‘Yes’.

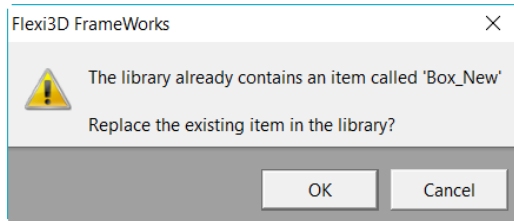
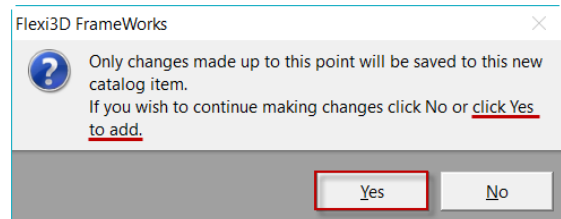

If the template already exists, you can choose to ‘Replace the existing item in the library’ or ‘Cancel’ and choose a new name.

Locate your **User** created Catalog templates by clicking on the **Browse Box Library** dropdown menu and selecting the **User Library** as shown below left.

Box_New has been created under BOX-WIZARDS / Standard which can now be opened and edited like any other template i.e. Construction view and standard template options are available.

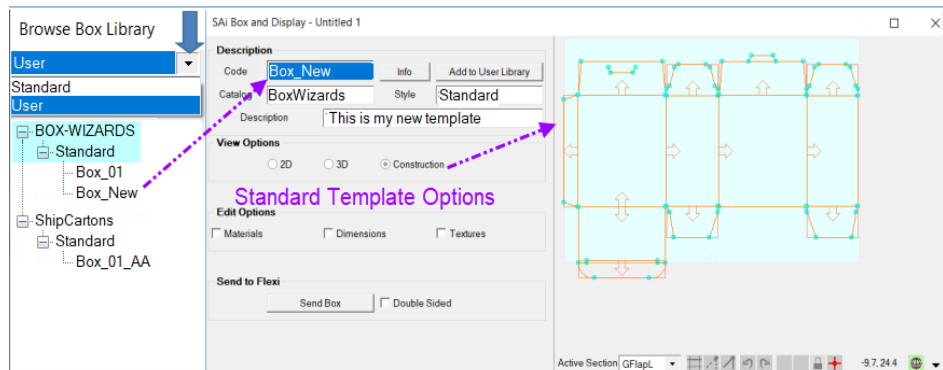

Chapter 2: Template Library and User Interface

The following discusses the Box Library and each of the interface elements available when you use the lightning bolt  button to [create a box/display using a template](#).

Remember:

- **Ctrl+Click** to **follow internal link** to quickly navigate to other parts of this document.
- **Return** from a hyperlink jump by using **Alt+left-arrow** [Only with Adobe]

Templates

Catalog

The box library includes a **Standard library** of templates organized in accordance with the system used by the international organizations [FEFCO](#) (corrugated board) and [ECMA](#) (folding carton), so that you can find and select designs by referring to the most commonly used codes on the market.

As shown, there is a **'View Catalog'** bar which, when clicked, opens a PDF with details of all available templates and includes images of each template in 2D and 3D Views. The **Help** menu also allows you to open the same SAI Box and Display Catalog PDF.

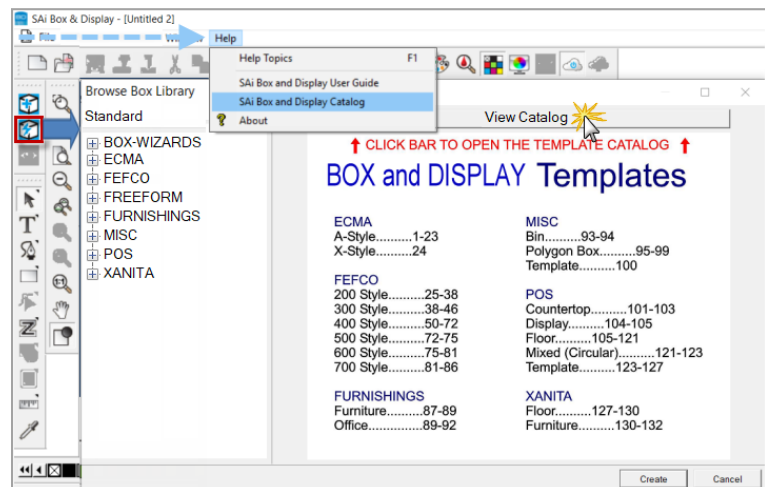

Library

Browse Box Library: When you start from a template, you will see this dialog. There is a **dropdown menu** to allow you to choose from the **'Standard'** library supplied or the **'User'** library of templates that you have created and saved to library.

Standard Library: This is **supplied** and you click on the plus signs to expand the libraries and sub directories. Then navigate through the **templates**, clicking on the codes to see a preview on the right.

When you have located the template you desire to work with, either **double click** on selection or click **'Create'**.

User Library: Contains templates that *you have created and saved* to library. After making changes to a template or your own FreeForm box, you can use the **'Add to User Library'** button as shown below, in the Friendly page.

See also [Chapter 3](#) - Friendly Page Controls

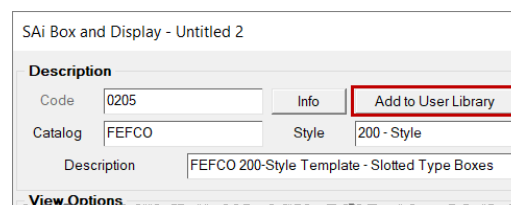
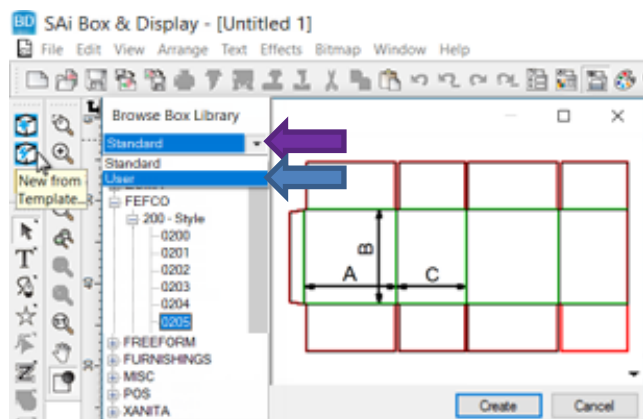

User Interface

The Box&Display User Interface, also known as the **Property Inspector**, is the next Window that appears.

Property Inspector

The property inspector is where the majority of the work takes place and is used to control, configure and manipulate the properties of the currently selected template.

The Property Inspector has two main parts.

1. The Friendly Page Controls on the left.
2. The Preview Pane on the right.



Friendly Page Controls

[Friendly Pages](#) are where related values can be grouped together and referred to with meaningful questions. Radio buttons, checkboxes and fields allow the user to define and control the process.

Send to Flexi: Use the **Double Sided** check box to determine how you want to send your design to Flexi. Ticked for both sides and unticked for top only.

Click on the **Send Box** button to open your design in Flexi ready for illustrating.

To return to Box&Display from Flexi, use the  **View in SAI Box Display** button on the toolbar.

Show Actual Panel Dimensions: can be turned on - available when **Dimensions Edit Option** is turned on and only in **2D View**, as shown in diagram above, and **Construction View**.

Preview Pane

The Preview Pane is used for viewing the progress or changes made to the design of the box/display and provides controls on the status bar.

3D Navigation in Preview Pane

The following allows you to look at your created 3D box/display to your satisfaction. [Hotkeys](#), [repeatable commands](#) and [mouse actions](#) can also be useful for saving time on some of the more common events.

- **Rotate the camera:**
Click and drag.
- **Pan the camera:**
Shift + Click and drag
or Left Click + Right Click and drag
- **Zoom the camera:**
Ctrl + Click and drag
or Mouse-wheel Up/Down
or Right click + Drag
- **Reset view:**
Click middle of mouse (wheel).

Active Section

In Construction View, the box is made up of a series of rectangles known as **sections**. These sections can only be edited one at a time, so it is important to know which one is the active one. You can double left click or right click and select "[At Section](#)" on any section to make it active.

- **Active Section** is always highlighted in light blue.
- Machine step **points** are a darker blue.
- Machine **steps** are denoted by the red lines.

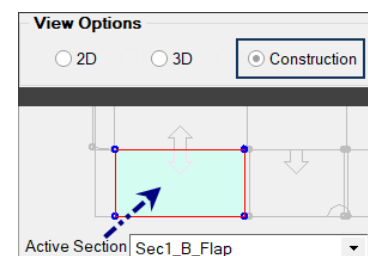

Design Canvas and Status Bar

The following is a discussion using the diagram below.

Note: If necessary, drag the window border and vertical divider in order to see the complete status bar.

1. Design Canvas – Preview Pane

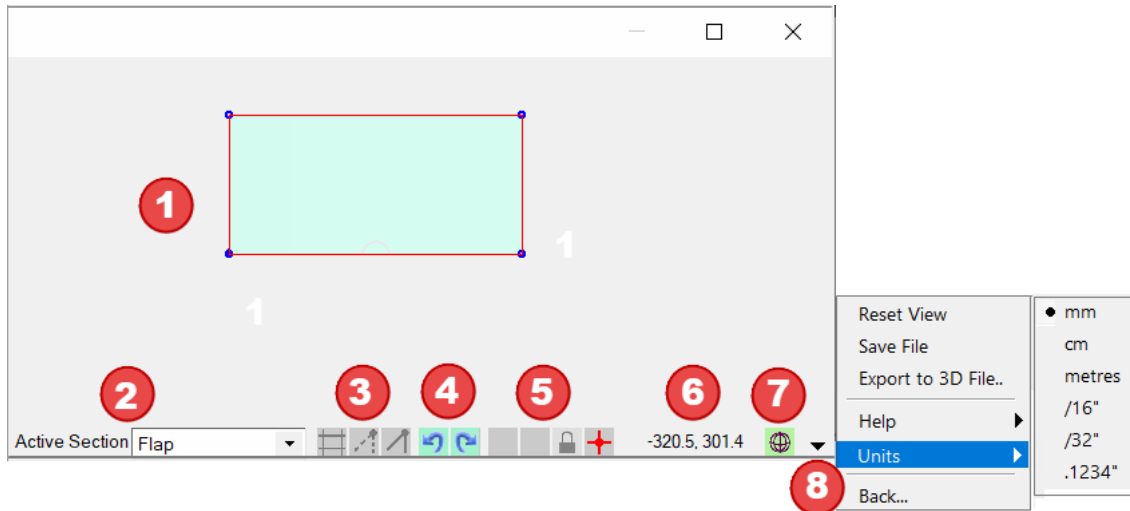

The **preview pane** displays your design in 2D, 3D or construction view.

The **status bar** displays information about the currently selected section.



2. Active Section drop down list – each section of the ‘Box/Display’ is automatically provided with a descriptive name for easy identification. You can only work on one section at a time and it must be made [Active](#) before working on it. Use the drop list menu to select required section.

3. [Snap Mode](#)

- a.  Snap to Grid
- b.  Snap to Marker
- c.  Snap to Machine Step Point



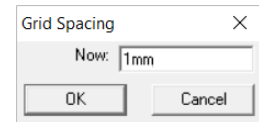

NB: Right click on this icon to open →





4. Undo – Redo

- a.  Undo = ctrl-X
- b.  Redo = ctrl-Y

5. Indicators









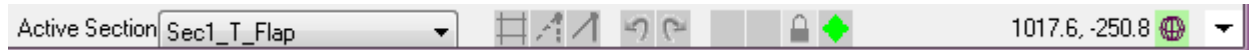

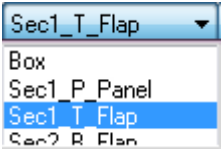
- a.  Section Failure – See [Notes on Error Indicators](#)
- b.  Point Failure
- c.  [Unlock/Lock](#) Imports
- d.  Keyboard Focus

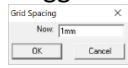
8. Menu drop down

6. X, Y [Coordinates](#)
7. Coordinates Selector
 - a.  Local
 - b.  Global
8.  Menu drop down
 - a. Reset View
 - b. Save File
 - c. [Export to 3D](#) File
 - d. Help documentation
 - e. Units – change default unit of measure
 - f. Back – Return to [‘Browse Box Library’](#)

The following pages discuss the status bar items in more detail.

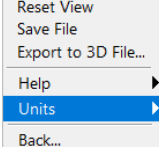

Item	Choices	Purpose
Section drop list		Displays the name of the current section (editable in the Dimensions section of the property inspector). Drop list of all editable sections.
Snap to grid	 Enabled	Snap to grid markers. Left click to toggle. Right click to change grid spacing.  Green if enabled
Snap markers to	 Enabled	Snap to marker machine step points. Left click to toggle. Green if enabled
Snap points to	 Enabled	Snap to any machine step point. Left click to toggle. Green if enabled
Undo and redo		Left click to step through command history. Green if steps are available. Shortcut keys: ctrl-Z (Undo) and ctrl-Y (Redo)
Error indicators		Left for section, right for machine step. Hover over the indicator for a tooltip describing the error. See Templates and No-Entry Left or right click the indicator to correct the problem - a message/dialog will appear <i>if a suitable action is available</i> . States shown from top: OK, Failed, Wait, No-Entry
Auto-unlock	 Enabled	Automatically remove library section protections as required for commands. See Chapter 4 for the consequences of this. Left click to toggle. Green if enabled
Focus indicator		Green if preview pane has focus, else a red cross . Left click in the preview pane to get focus. Shortcut keys and the mouse wheel have no effect if the pane does not have focus, and may cause effects in other windows
Cursor location	1017.6, -250.8 	Current cursor position in coordinate system selected by the adjacent global/local toggle.
Global/Local	 Global	Left click to toggle. Greyed out if local. Green if global,
View Menu		Left click to show complete menu of previews. Left click in menu to select.

Chapter 3: Template - Friendly Page Controls

The following discusses the Friendly page controls when using Templates .

For a discussion on Friendly page controls when using Freeform, see [Chapter 6](#).

Properties

At the top is mostly information about the template you have selected. We can see that we have selected the 0205 template.

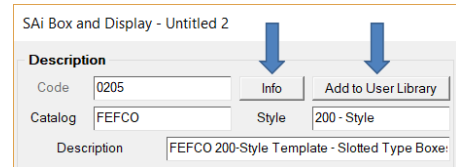
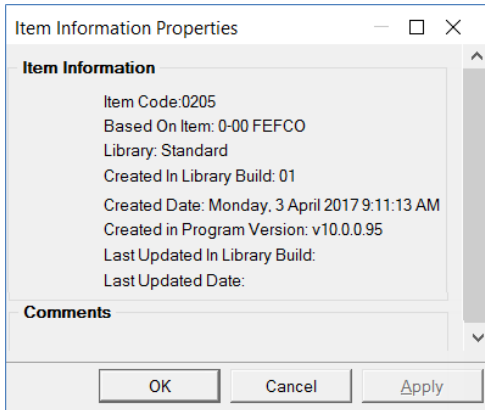

If applicable, the [Info] button will be active and when pressed will open a dialog with extra information, shown left.

Add to User Library

The **User** library is a separate to the Standard library, and **contains only templates that you have created and saved to library**. To save a modified template or FreeForm box for future use the [Add to User Library](#) button. You can make changes to the Description, or not, as required before 'Add to User Library' – example below shows result.

Note: This will only save the current state of your box design in **User** Library, located by *using the dropdown*. [Default library is Standard].

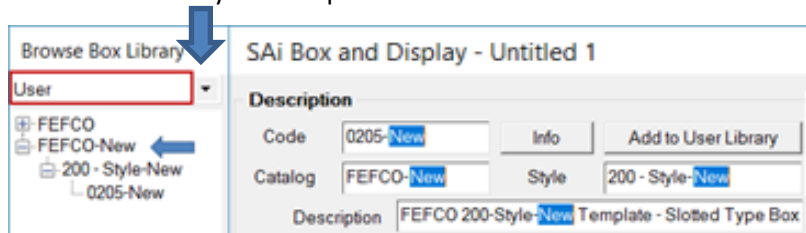

You can choose to 'Replace the existing item in the library' OR 'Cancel' create a new code/name – Example message →

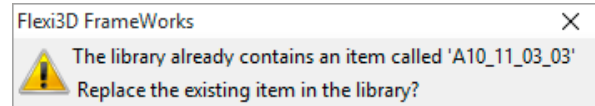

View Options

Using the View Options, you can select how your template is displayed.

[The following template displayed is the ECMA A10_21_03_03]

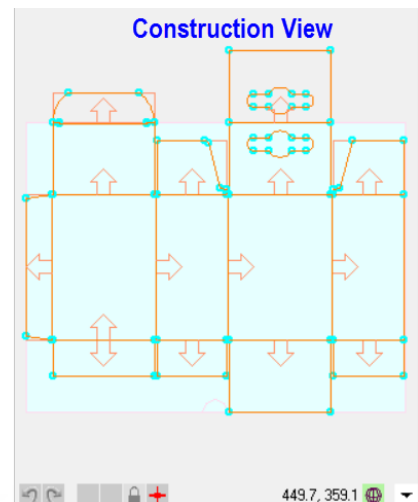
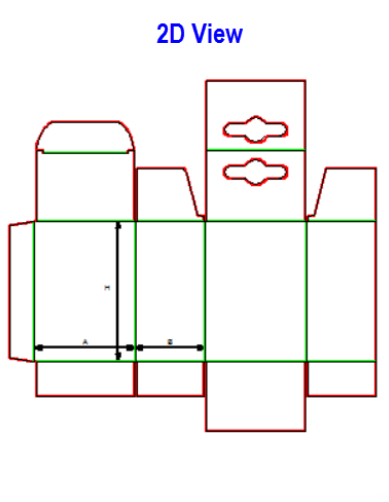

3D View

Tutorial Video  [3D View Controls](#)

Folding Control

The Folding Controls are only available when you are in the 3D view. Use the **Amount slider** or enter a number directly into the **edit box** between 0 and 100 to fold and unfold the current box template.

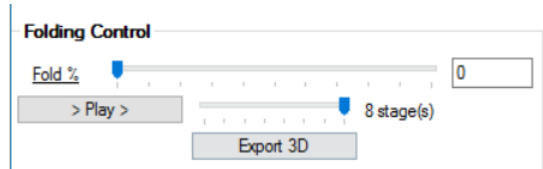

The **Play** button allows you to run an animation of the box or display. The stages slider is used to fine-tune the speed of the folding. [See end of [Tutorial 103](#)]

For setting the Folding Sequence see [Tutorial 102](#).

With the [Export 3D](#) button, you can save your design to a 3D pdf file. You can export as many times as you like e.g. to show customer box at different stages of folding. The customer will be able to rotate, pan, zoom in/out the box just as you can in Box&Display. See [Chapter 5 – Mouse Actions in 3D](#).

Important Note: Adobe Acrobat Viewer (free version download) required to view.

3D Export

For 3D Viewing you need to have Adobe Acrobat Viewer installed. When you press the 3D Export button discussed on the previous page, you will get this message ‘Launch PDF Viewer?’ Click ‘Yes’ to continue.

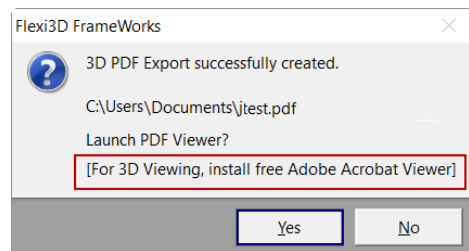

Note that you will need to **click once on the pdf view** upon opening. Click **Options** and select **‘Trust’** from dropdown menu.

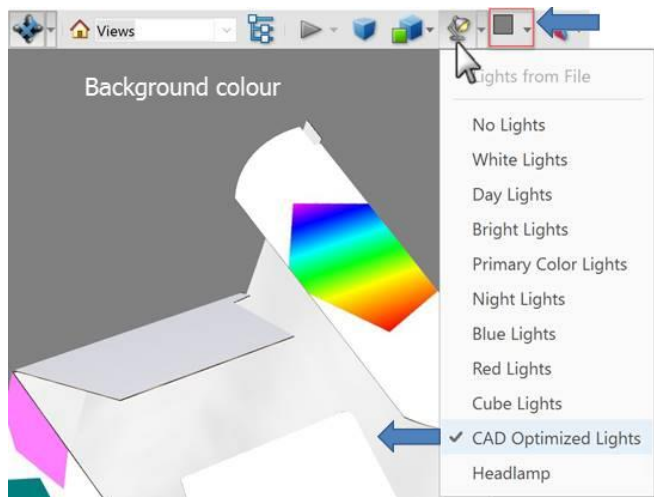
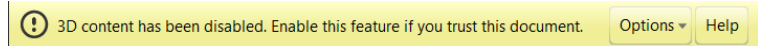

You will then see your box presented similar to screen grab shown left.

Background Color: When you first open the pdf, the background will be black, so you may like to change the background color using the icon indicated by the blue arrow.

Lights from File: It is recommended to select the CAD Optimized Lights for a better display as shown.

3D Assemble

Some boxes may be made in sections as shown below, top right. [Template POS > C8-230 x 300 FSC]. When this is applicable, the **Remove/Transfer Dividers** and **Remove/Transfer Tray** buttons will be presented. Other boxes may only have an **Assemble Unit** button – See [Tutorial 203 Sloped Shelf Display](#).

Use these to **Assemble** the box, as shown in the insert.

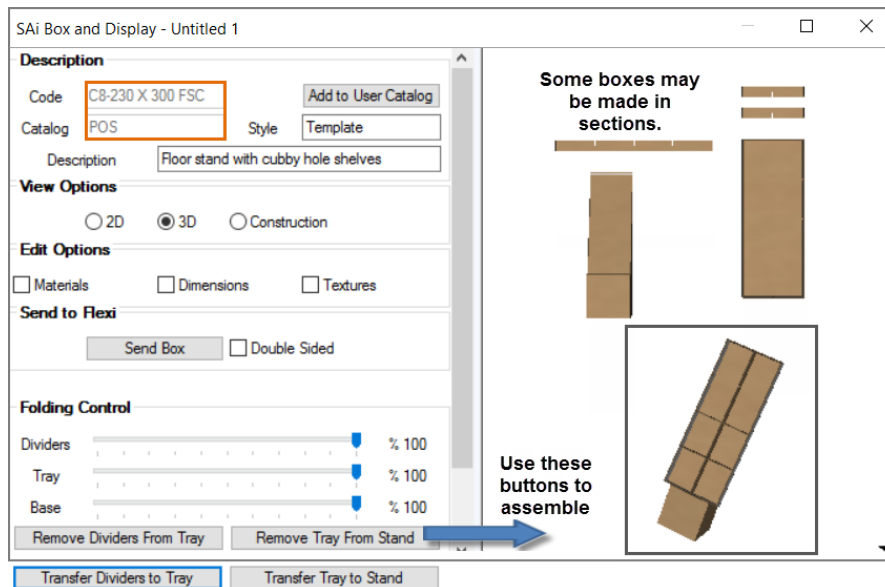

Edit Options

Use the check boxes to expand the three main edit categories...

- Materials
- Dimensions
- Textures

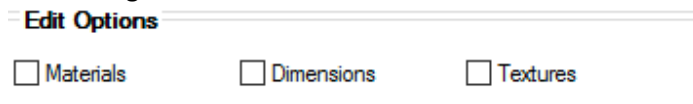

Materials

By ticking the materials check box, the properties for the material that will be used for the selected template (0205) are shown.

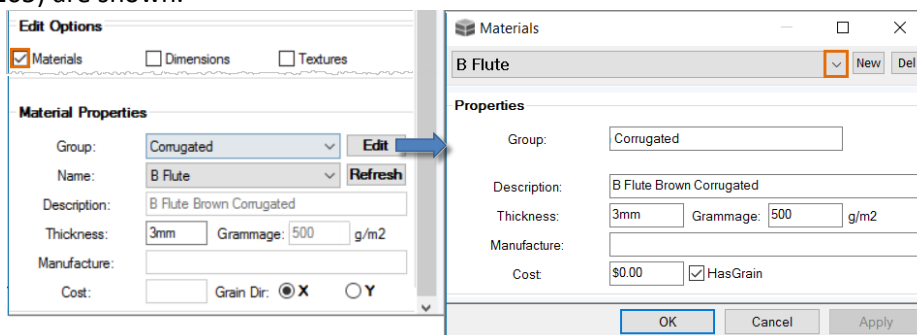

All the properties are user defined and can be edited using the Materials editor, accessed by clicking on the **Edit** button, as shown above. Use the dropdown menu to see list of materials.

To create a 'New' Material use the **New** button, as shown. 'Delete' a material by selecting and then use the **Del** button.

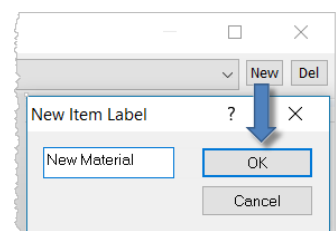

Tutorial Video [Edit Materials](#)

Dimensions

Tutorial Video  [Dimensions](#)

Show Actual Panel Dimensions, if checked, provides the dimensions of individual **Panels** in the preview panel, in 2D View, shown, and Construction View. Note that dimensions include Fold Allowance which in case is 3mm.

Edit boxes are available to enable you to make changes to outside dimensions. Inside dimensions can be figured out from the Material Thickness (shown **3mm**). For example, take off 2 x thickness and add a small clearance adjustment, if required.

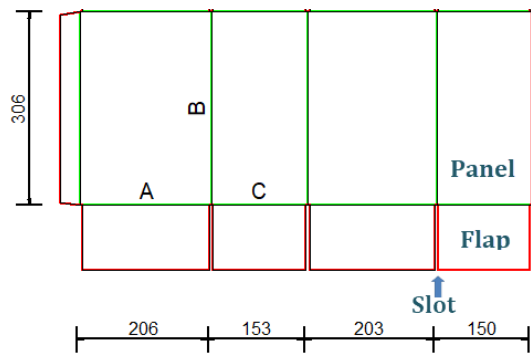

Lock Proportions check box will set all panel widths, panel heights, flap lengths and flap settings to be proportioned by the **(A)** dimension.

Setup the box to your desired sizes and then click on the checkbox.

Dimensions

Show Actual Panel Dimensions Lock Proportions

(A) (B) (C)

By changing the **(A)** dimension all the sizes will change accordingly.

Show Actual Panel Dimensions Lock Proportions

(A) (B) (C)

Once you have resized, you can uncheck the 'Lock Proportions' checkbox, which will allow you to make further adjustments by editing B and C sizes directly.

Fold Allowance options are available, if applicable, as shown here for a 0205 template, note difference...

(A) (B) (C)

Fold Allowance Slot Width

Unfolded Size: (X) (Y)

Turned **Off** – X/Y respectively are 734.8 / 506mm

Turned **On** – X/Y respectively are 743.8 / 512mm* (shown)

*Y takes into consideration Material Thickness and Fold Allowance.

Slot Width - the first three dimensions in the drop down are controlled by a formula i.e. Material thickness multiplied by 2, *3 and *4 and the last three are static. You can, however, manually type a dimension into the edit box.

- 6mm
- 9mm
- 12mm
- 6.32mm
- 8mm
- 9.52mm

Add Lid and **Insert Settings** options are available, if applicable, as shown here for a FEFCO 0300 template. See **Tutorial 208 Box Inserts** to create DXF cutouts to anchor items within box.

The **Add Lid** option allows you to adjust the **Lid Gap** as shown...

The first box has a gap of **0mm** and the other has a gap of **10mm**.



Dimension

Show Actual Panel Dimensions Lock Proportions

(A) (B) (C)

Add Lid Lid Gap (D)

Default Offset Use Material Thickness

Unfolded Size:

(X) (Y)

Insert Settings

Add Height

Panels

The mains sides of the box are called **Panels**.

Use the **dropdown** to select the panel you wish to work with. Note Panels are numbered from Left to Right.

The **Edit** button opens the Edit Panels Properties, shown below, for the currently selected Panel.

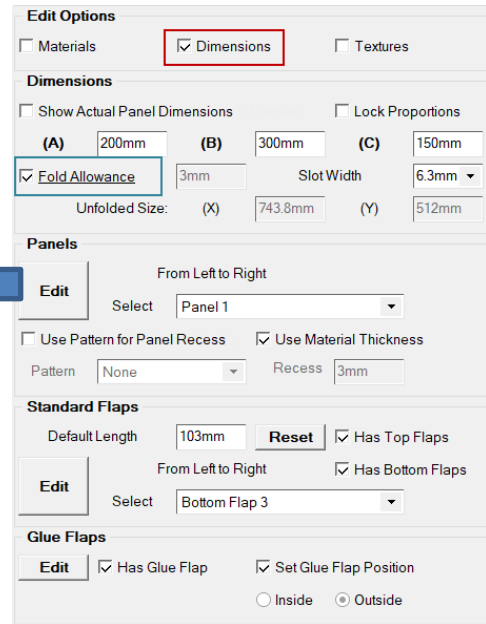
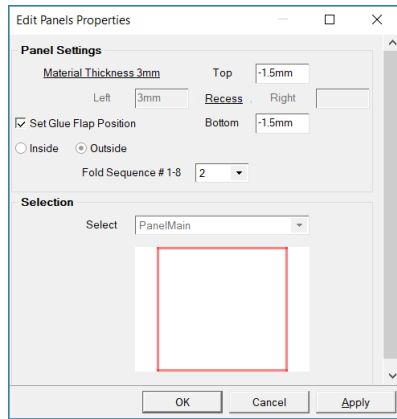

Edit Panels Properties

Recess can be used to change the overlap of flaps or panel in relation each other. For example, -1.5mm entered into the top and bottom recess will make flaps connected to the top and bottom of this panel fold in below those of panes with a 0mm recess.

Use the **Fold Sequence** dropdown to select the order in which you want the panel to fold.

An **Advanced** button may be present which will open more options for the panel, similar to the one discussed on the next page.

Use the **Select dropdown** to select the type of panel to import.

Another way to recess is to **Use Pattern for Panel Recess** to adjust panel heights, and the **'Use Material Thickness'** to recess by either using the default Material or specifying required recess (shown changed from 3mm to 20mm).

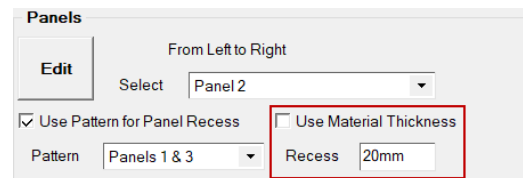

The benefit of using this method is that you can use one strategy for creasing the perimeter foldline. The internal fold lines remain separate from the perimeter.

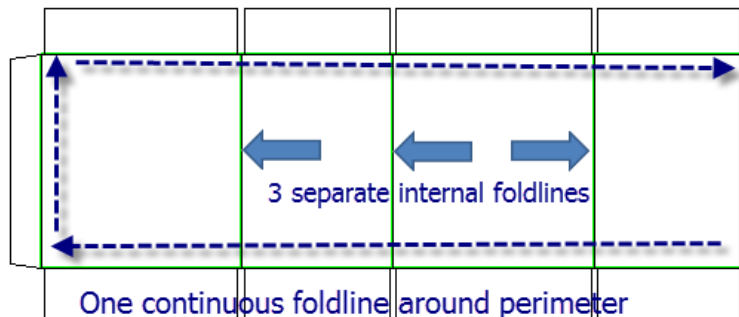

Panels and Slots

The image below shows Panel 2 with a Top Recess of 20mm and a Slot Width of 20mm to show that the perimeter foldline is continuous, in a zig zag pattern for smooth fold/cut.

See [Template Tutorial 202 - Toolpath and Fold Lines](#).

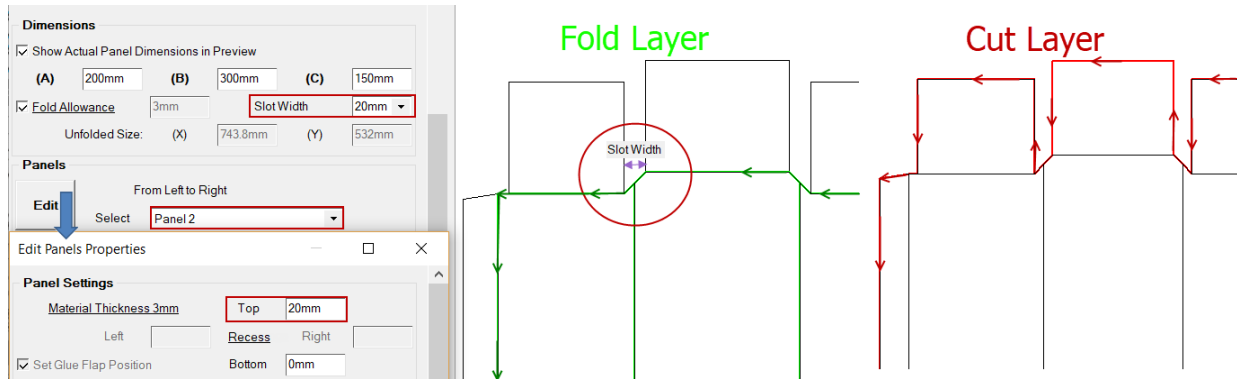

Standard Flaps

The options for Flaps work much the same as Panel with some differences.

The **Default Length** will set the length of all the standard flaps unless they have previously edited.



Pressing the **Reset** will set all the flaps to the default length including the edited ones.

If your design requires it, you can use the **check boxes** to remove all the flaps across the **Top** or the **Bottom** of the box.

Tutorial Video [Edit Flaps and Panels](#)

Edit Flaps Properties

Select and **Edit** the desired flap on the Edit Flaps Properties page.

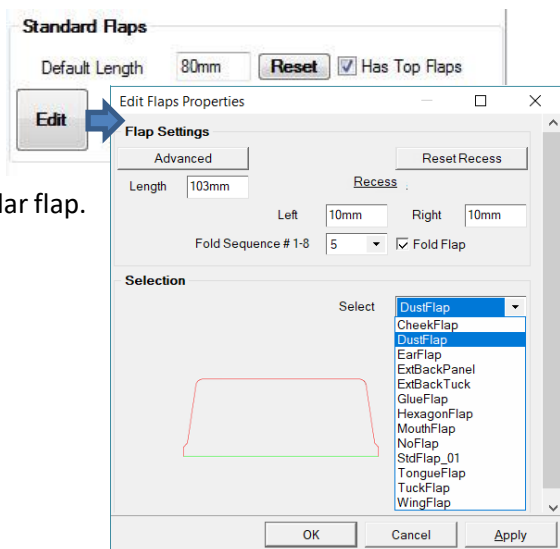

Most of the flaps have an **Advanced** button which opens the Advanced Edit Properties page for this particular flap.

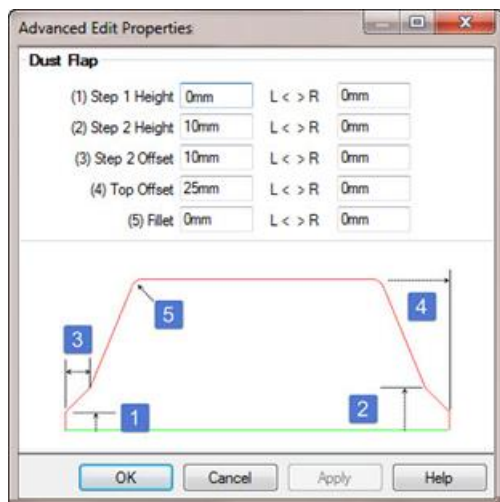

Most of the flaps from the import library will have a similar page as this one, with simple diagrams defining what the different parameters will change. The numbers on the diagram correspond to the edit boxes.

Tutorial Video  [Advanced Flap Settings](#)

Glue Flaps

Similar to the panels and standard flaps the Glue Flaps can be edited but usually have less options.

The default Glue Flap Position is Outside. If you want to override then you need to turn on 'Set Glue Flap Position'. As shown the glue flap can be folded 'Inside' or 'Outside' of box.

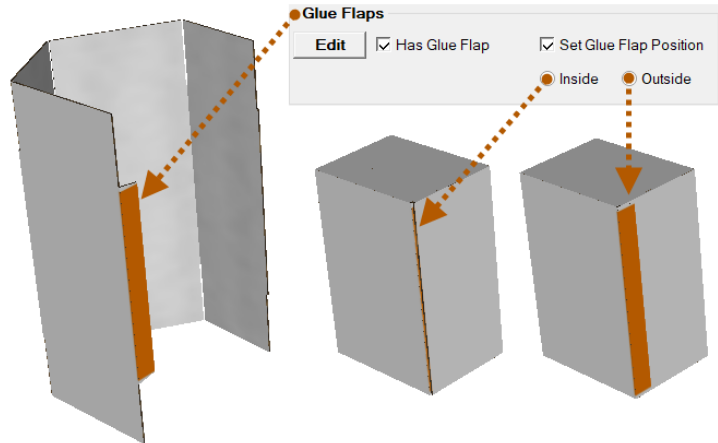

Textures

Tutorial Video  [Local Textures](#)

The 'Show Annotation' checkbox allows all annotations to be turned on/off. This checkbox is located either under **Local Textures** as shown right or under the **Annotation Settings** as shown below.

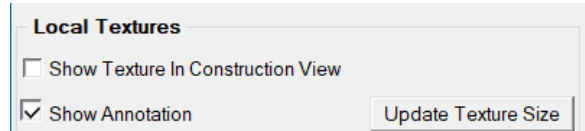

If applicable, you can change the **Annotation Settings**. The FEFCO 0205 template, shown below right, has annotations i.e. **A**, **H** and **B**. Use the **Edit** button to change these.

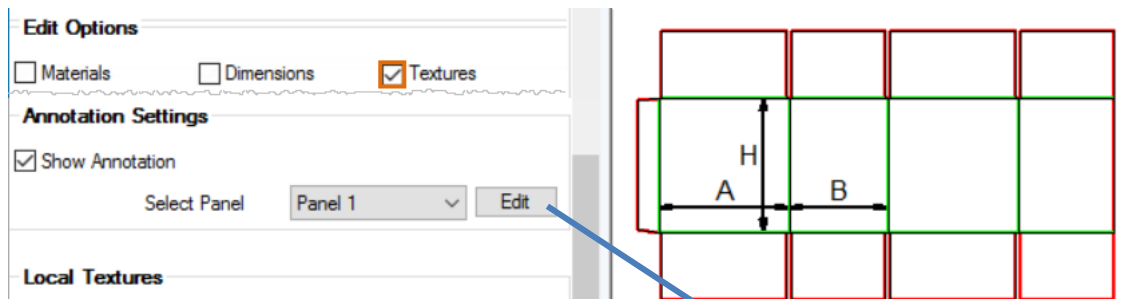

Annotation Settings

The **Edit** button opens the **Advanced Edit Properties** dialog which allows you to make changes to position and look of annotations and arrows.

The diagram below shown changes to **Panel 1 – Annotation 1** i.e. to A and its line. NB: B is on Panel Annotation 3 not ticked →

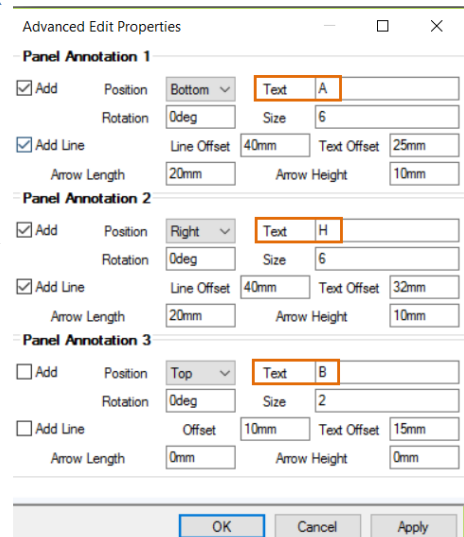
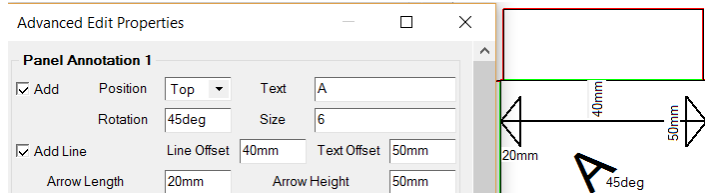

Texturing Modes

Box&Display has three texturing modes

1 Local Mode

- Textures are located on your local drives.

2 Embedded Mode

- Textures are provided by Flexi.

3 Local\Embedded

- Textures are both located on the local drives and provided by Flexi.

When a new Box&Display project is started, the texturing is set to **Local Mode**.

If you click on **Textures** in the Edit Options, the default textures will be displayed in the **Local Textures** properties dialog.

By default, at this stage these textures cannot be deselected. You can, however, click on the **three buttons** to the *right of the check boxes* to browse your computer for different textures, shown below. The **Texture Properties** (indicated with blue arrows on diagram) are the images for each of the faces.

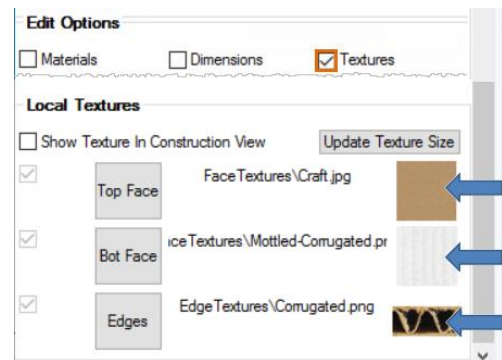

C:\...\Flexi3D\Bitmap\FaceTextures

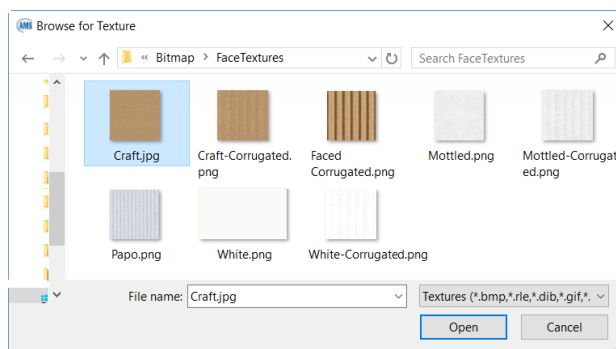

If you have made changes to the size or construction of the selected item, the *texture may no longer fit the shape correctly*. If this happens click on the **Update Texture Size** button which will resize the texture canvas to the extents of the shape.

3D View will show you the result of texture changes.

To embed textures from Flexi into your project you must first send your design to Flexi from Box&Display to place in the Flexi design environment. See next page – Send to Flexi.

Once you have selected the **View in SAi Box Display**  option from the Flexi toolbar, the Local Textures check boxes will be activated for the faces that can be changed. You will be able to switch between **Local** and **Embedded** textures.

You can use the **Show Texture in the Construction View** checkbox to do things like tracing around an image for a [flip-up cutout](#).



Chapter 4: Formula Controlled Sections/Flaps

Whether you design a box using a template or freeform, everything works the same. The templates, however, will almost always have parametric/formula controlled/imported sections/flaps and this generally will lead to an *initial blocking* of freeform, which will be indicated by a red indicator. 

This means that you must look at the *error messages* behind the red indicator icons on the status line whenever it blocks an action. Click on that red status indicator and accept the unlock/message to allow things to proceed. See [Tutorial 200](#) and [Tutorial 109 – Convert to Standard Construction View](#)

[Context menu](#) options will also be greyed out when you are being blocked like this, as a lot of freeform commands simply cannot be done without first removing that formula/import control.



Error Indicator

- **OK** -- no error
- **Failed**  - the last command attempted was unsuccessful. The indicator stays red and hoverable for about 30 seconds following this event.
- **Wait** -- the current command is taking a long time and you must wait. No action is available to fix this state, but control should eventually be regained.
- **No-Entry**  - the active section or machine step is protected from some editing commands, which you will see greyed out in the context menu. Left or right clicking the indicator usually allows the protection to be removed. *However, doing this has consequences.*

Removing the "imported" flag from a library section or subtree means that it will no longer be automatically updated if you or the developers change it in the library. Removing the "formula" property from a library section removes the **Active Section/More** box from the property inspector. (If it remains visible, then its function is reduced to duplicating the controls already visible in the Active Section group)

“Import section reference. Convert to local copy?”

Often flaps come from an internal sublibrary and are parametrically controlled with a friendly page available to let you change various parameters for the shape and size of the flap. The flap itself gets loaded from the sublibrary and will automatically refresh sometimes (e.g. when you reload an old drawing). But if you want to modify this imported flap in any way, you need to make a copy of this imported flap, so that in future it won't get refreshed and lose your changes.

Box&Display knows the types of changes where this local copy is needed and insists that you “Convert to local copy”, if it is required. In some cases, you will see greyed out menu options, showing things you cannot do. There are Error Indicators such as the “no entry”  that appears on the status bar - clicking on this will prompt you to “clear the imports”. If you are able to select a menu option but Box&Display cannot proceed, there will be a big red dot  ‘Failed’ indicator and you can click on that as well.

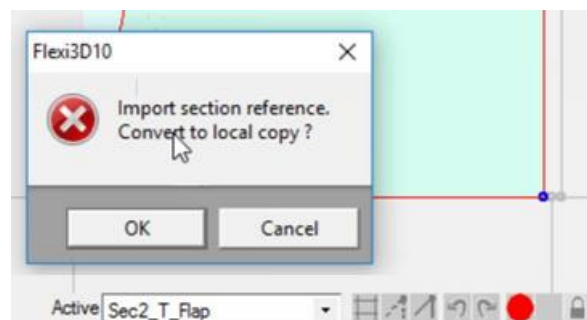

Tutorial Video  [Convert to allow changes to template](#)

“Formula-controlled section. Eliminate formulas?”

Making a local copy of a section is still not enough if the shape is formula controlled. Many flaps have parametric controls within them, for example altering a parameter might affect more than one dimension in the shape. To add/remove points in the shape or drag points around when they are part of the boundary of a shape, you need to eliminate these formulas. Again, Box&Display knows which commands you need to do this for and blocks them. If you click on the red dot on the status bar in this case, you will get this prompt.

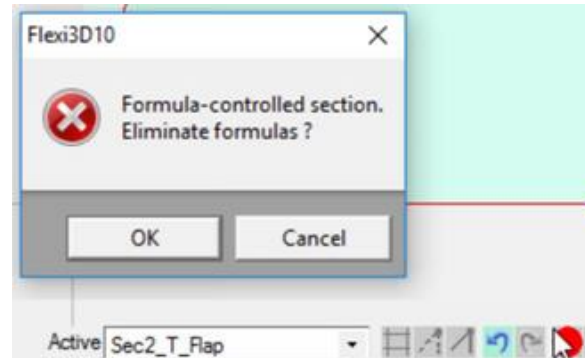

Once you press OK to eliminate formulas, the parametric control of the shape of this flap will be removed, along with internal formulas that were there to control it. You can then freely change the shape in almost any way. If you change your mind, don't forget you can use the Undo button to bring back those formulas. Or if it happened too long ago, the easiest thing is to delete the whole flap and bring in another fresh one from the flap sub-library. See [Tutorial 109 Import Predesigned Flaps](#).

You might also wonder what happens if you resize a box which has a flap where the formulas have been removed. In this case, the flaps do resize still, but things are scaled proportionately - See [Tutorial 109 – Resize](#). In some instances' the result will be quite acceptable, but in others, the flap may have parametric properties where a simple scaling is just not good enough. If this is the case, you may need to bring back a fresh flap, or edit the shape to adjust it, whichever is easiest.

Lock / Unlock

Another way to accomplish the same thing is to use the Auto-Lock function. When you Unlock  the section, it will unlock imports and formula sections. This means that you will have the ability to do make any changes to points, without converting to Construction View, discussed above.

Left click to toggle between Lock  / Unlock .

Consequences

Removing the "**imported**" flag from a library section or subtree means that it will no longer be automatically updated if you, or the developers, change it in the library.

Removing the "**formula**" property from a library section removes the **Active Section/More** box from the property inspector. (If it remains visible, then its function is reduced to duplicating the controls already visible in the Active Section group).

Stretch Mode and Scaling

Tutorial 104 discusses [Scaling and Stretch Mode](#). In the examples given there at [Step 2](#), it shows how you can change the stretch mode to **Proportional**, because the default will identify points close to a corner, e.g. the chamfer, and make them default to stretch mode “locked to corner”. [See also **Tutorial 105** [Parametric Scaling](#)]

Even a wiggly corner shape will be maintained in its absolute size and shape, or could be scaled as the overall size scales, or indeed could be maintained as absolute distances in the x-direction but scaled in the y-direction, or vice-versa.

Removing formulas certainly will lose something if you need to do size changes later on. Looking at some of the complex flap shapes, with locking tabs and slots and so on, the full parametric solution provided *before* you remove formulas is of course carefully designed to work fully and will be superior to any guesswork approximation you can make by use of any form of pure scaling.

Removing formulas will also remove the ability to do some other types of configuration changes, e.g. the flap might have a setup that allows for two, three or four slots. In the original friendly page control, there might be a dropdown that lets you select which option you want. No amount of scaling will change two slots to three slots and so on. On the other hand, if you set a flap up at the desired size, and other configuration parameters are set to suit your requirements, then removing formulas allows those last minute freeform adjustments that just are not catered for in a preconfigured design. You can make little one-off changes, cut holes, add little notches, make a change in the border to allow for some extra clearance somewhere etc.

Chapter 5: Context Menus, Commands and Actions

Whether you design a box using a template or freeform, everything works the same. The templates, however, will almost always have parametric/[formula controlled/imported sections/flaps](#) and this generally will lead to an *initial blocking* of freeform, which will be indicated by a red indicator. 

Context menu options will be *greyed out* when you are being blocked like this, as a lot of freeform commands simply cannot be done without first removing that formula/import control.

Active Section - Main Context Menu

When you right click on a [Section](#) in the Preview Pane, it will make that area active [See [What is an Active Section?](#)] and you will be presented with the following context menus...

When right-clicking elements in your software, a **context menu** is displayed. The context menu will *differ according to the element* that you are right-clicking on.

Shortcut Keys are available where indicated on the context menu and allows you to select the command using the keyboard.

Example: To Add Machine Step > Hole → Hit **N** on keyboard and then **H** for Hole from the available fly out menu indicated by ▶

1. Opens the **At Section fly out menu** ▶
Shortcut Key: Right Click **S**
2. Opens Add Machine Step **fly out menu** ▶
Shortcut Key: Right Click **N**
3. This option will take you to the parent section for the current active section
4. Resets View to the centre of the preview pane
5. Click to show hidden sections
6. Click to show [hidden machine steps](#)

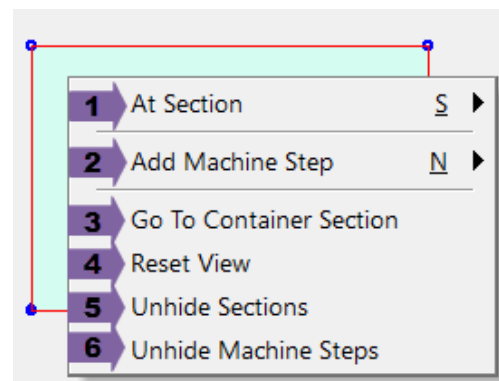

Fly Out Menus

At Section options

1. Same as Ctrl + C
2. Releases flap height constraints to allow you to [reset Section Height](#)
3. Set Section invisible
4. [Clear Section](#)
5. Clear all Sections attached to Active Section
6. Clear all Sections attached to Active Section and Active Section as well
7. Attach one end of section's base fold ([Hinge](#)) to a specified point in its parent section

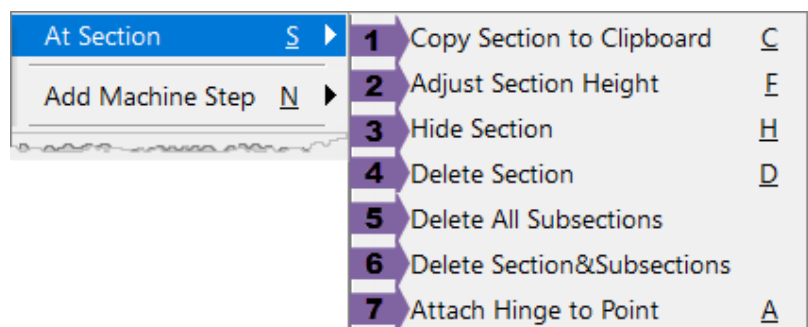

Add Machine Step options

1. Sets of points for construction use (local to construction preview)
2. Internal [hole](#) (or cutout if it intersects the border)
3. Set of lines which are [scored](#) rather than cut in production
4. Set of lines which are [perforated](#) rather than cut in production
5. Specifies annotation with [dimensions](#)
6. Specifies annotation with [labelled arrows](#)

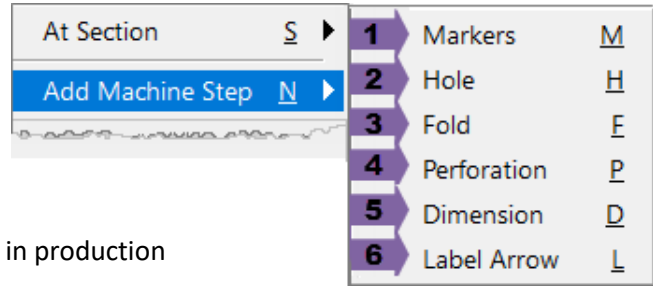

These machine steps can be [formatted](#). See also [Chapter 8](#) on Machine Steps.

Point, Line or Machine Step – Main Context Menu

When you right click on a [Point](#), [Line](#) or [Machine Step](#) in the Preview Pane, you will be presented with this menu and access to related Fly Out menu's...

1. Add a new point before an existing Point
2. Add a [new point after](#) an existing Point
3. Clear a Point
4. Move a Point by [dragging](#) it to a new location
Holding down the 'shift' key while dragging will constrain to last point.
5. Opens the At Point [fly out menu](#) ▶
Shortcut Key: Right Click [P](#)
6. Opens the At Line [fly out menu](#) ▶
Shortcut Key: Right Click [L](#)
7. Opens the At Machine Step [fly out menu](#) ▶
Shortcut Key: Right Click [M](#)

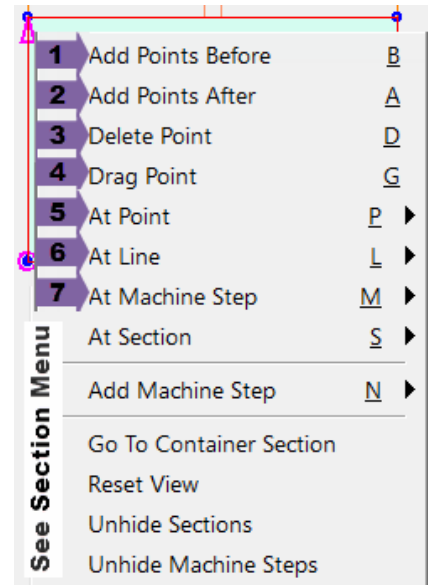

Fly Out Menus

At Point options

1. Add a [new Flap](#)
2. Same as Ctrl – V
3. Paste flap and its sub-tree
4. [Import](#) current import flap selection
5. Clip off [corner](#) at a 45-degree angle
6. [Round off a corner](#)
7. [Adjust two arc Corners](#)

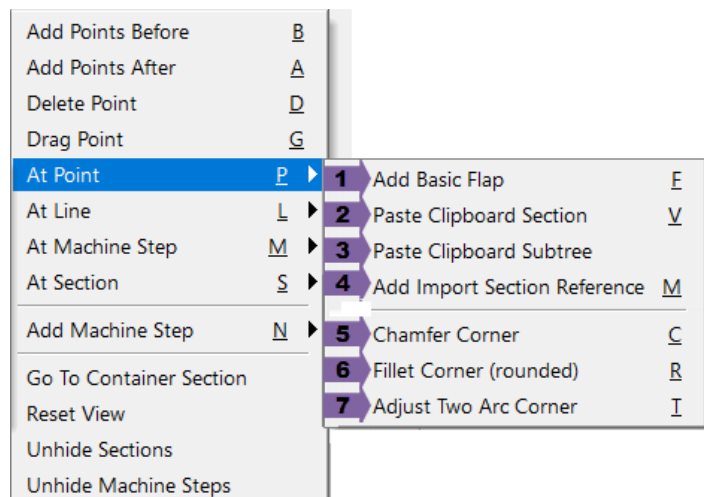

At Line options

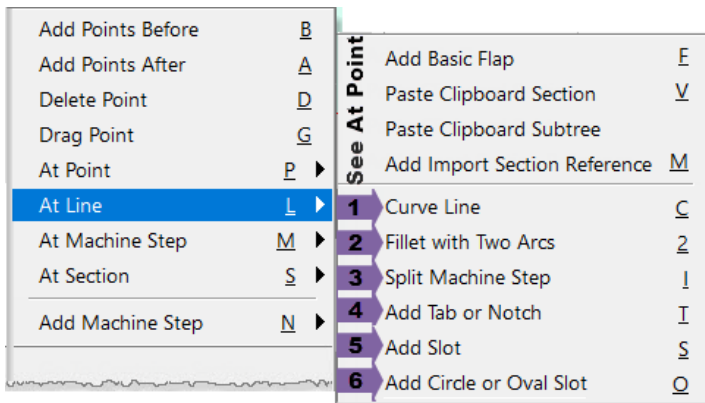

See [At Point](#)

1. [Curve](#) a Line with [given radius](#)
2. [Fillet with Two Arcs](#)
3. [Split](#)-machine step into two
4. [Tab or Notch](#) (+ or – height setting)
5. [Slot](#) controls for inner/outer/centre
6. [Circle or Oval Slot](#)

Note: Most commands on the **At Point** and **At Line** fly out menus are [repeatable](#).

At Machine Step options

1. [Open or close](#) a machine step between the first and last points
2. Select a group of machine step points
3. [Flip a machine step](#) from one side to the other of the section
4. Copy a group of machine step points from one side to the other.
5. Fillet all machine step corners
6. Create a [Flip-up](#) from perforation Machine Step
7. Created [Machine Steps](#) such as dimensions and marker, can be [formatted](#)
8. Clear a machine step
9. Clear selected machine points
10. Set machine step [invisible](#)

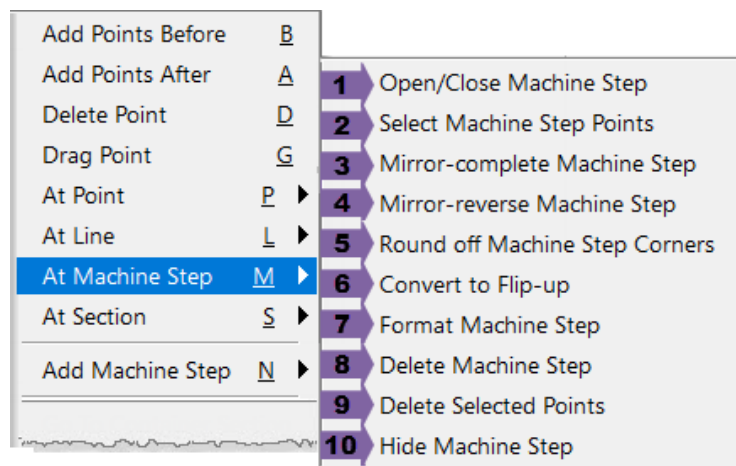

See also [Modal Cursors](#)

Stretch Mode options

These options are only made available when stretching points. See Tutorial 104 [Stretch Modes](#)

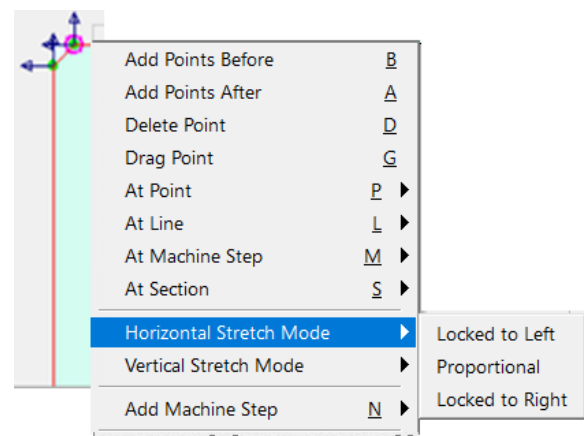
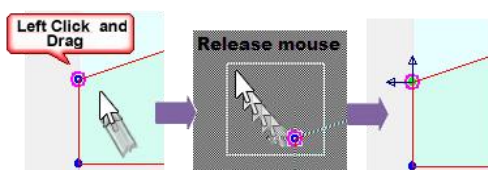

Hotkeys

- **ctrl-C** -- copy active section to clipboard (same as At Section/Copy Section to Clipboard) (◆)
- **ctrl-V** -- paste clipboard section to selected line (same as At Line/Paste Clipboard Section) (◆)
- **ctrl-Z** and **ctrl-Y** -- undo and redo (◆)
- **ctrl-R** -- repeat last command used (see List of Repeatable Commands below) (◆)
- **'.'** (**period / full stop**) -- invoke numeric entry dialog (◆)
- **<Delete>** -- delete active point (◆)
- **1 to 9** -- use Dimension Quick Entry value (hold the digit key down and left click)

Tutorial Video  [Parameters](#)

- **Context menu accelerator keys** -- the [context menu](#) must be open to use these
For example: **L** > **F** are the accelerator keys to At Line > Add Basic Flap.
- **shift** – holding down the shift key while moving a straight line, constrains the line to last point
◆ *if necessary, left click on the pane first to get mouse and keyboard focus.*

Repeatable commands:

The following commands can be repeated using **ctrl-R**. **NB:** Repeats only the last command executed.

- | | |
|--------------------------------|---------------------------|
| • Drag Point | • Chamfer Corner |
| • Add Basic Flap | • Fillet Corner (rounded) |
| • Paste Clipboard Section | • Adjust Two Arc Corner |
| • Paste Clipboard Subtree | • Curve Line |
| • Add Import Section Reference | • Fillet with Two Arcs |

See **Tutorial 107:** [Repeating Commands](#)

Mouse Actions

- ◆ *if necessary, left click on the pane first to get mouse and keyboard focus*

Construction Preview

- **Zoom:** Use mouse wheel to zoom (◆)
- **Pan:** Hold middle button (or Left and Right buttons) and drag.
- **Select Sections:** Double left click selects sections
- **Select Points:** Left click and drag. A rectangle will display, [selecting points](#) for setting stretch modes. (Hold 'Ctrl' to toggle and 'Shift' to extend)
- **Select Lines or Points:** Left click selects lines or points as active.
- **Context Menu:** Right click on Preview Pane or line/point of Active Section.

3D Preview

- **Zoom:** Use mouse wheel to zoom (◆) or Right click, hold and move mouse up & down on the screen.
- **Pan:** Hold Left and Right buttons and drag to pan in any directions
- **Rotate:** Left click and drag to rotate the image (in centre to rotate out of the viewing plane, around the edge to rotate in the viewing plane)

Construction View Navigation:

- **Zoom:** Use mouse wheel to zoom (◆)
- **Pan:** Hold middle button (or Left and Right buttons) and drag to pan.
- **Select Sections:** Double left click selects sections (flaps)
- **Select Lines or Points:** Left click selects lines or points
- **Context Menu:** Right click on line or point gives a context menu.
- **ctrl-C** and **ctrl-V** are copy and paste (◆)
- **ctrl-Z** and **ctrl-Y** are undo and redo (◆)
- **ctrl-R** is repeat last command (◆)
- **'.'** (**full stop**) is invoke numeric entry dialog (◆)
- **<Delete>** is delete active point (◆)

Chapter 6: FreeForm Construction Preview Interface

The Friendly page is the left hand pane of the BD Property Inspector.

The Friendly page shown is only available with FreeForm  and the following discussion pertains to the numbers in the image.

Check the **Dimensions** checkbox to display the items relevant to the **Construction** preview.

1. **Send to Flexi/Send Box** and **Double Sided** -- sends the current box to Flexi for illustration. If Double Sided is checked then the design is repeated *upside down* below the original. Illustrations in the 'upside down' area are used for the bottom face of the box.

After illustrating click Flexi's **View in SAi Box Display**  ("eye") button to send the results to BD (visible in 3D preview only).

2. **Dimension Quick Entry/Base Line Width** -- sets the width of the initial Base Line, shown as a dashed line in the preview pane, which determines the width of the root section. This value may be used to scale the entire box if the required stretch options are used (see [Tutorial 104 Simple Scale & Stretch Modes](#)). Changing this value after the box is illustrated requires rescaling the Flexi artwork.

3. **Dimension Quick Entry edit fields** and **More button** -- used for entering scaling parameters (see [Tutorial 105 Parametric Scaling](#)). Parameters may be for immediate use with the 1...9 numeric **shortcut keys**, or may be used for parametrising a basic design for creating different sized boxes. Note that in the latter case changes in scaling may require re-illustrating the box.

Boxes 1-9 can be used for the many repeatable dimensions that might be used throughout the building of your freeform box. For example, panel widths, flap lengths, chamfers and fillet corners. These dimensions are used in conjunction the construction tools.

The **More** button in this section opens a dialog box that lets you extend the use of the 1-9 input controls. The use of this dialog is discussed in [Tutorial 105](#).

4. **Active Section/Name** -- allows renaming the active section. Section names are used in the status bar drop list. If you use illegal characters, or accidentally rename a section to have the same name as another section, then the name is automatically modified to prevent any conflict.
5. **Active Section/Height** -- allows changing the height of the active section. There is also a context menu command for this purpose: **At Section / Adjust Section Height**
6. **Active Section/Fold Angle** -- by default sections fold to 90 degrees when Fold% is 100%. This can be adjusted here, and Clockwise can be unchecked to reverse the fold direction.
7. **Active Section/Scale Ht w Wth** -- "scale height with width". If checked the aspect ratio of the section remains constant if its width is changed. Otherwise the height remains constant if the width is changed. (see [Tutorial 104 Simple Scale & Stretch Modes](#)).



8. **Active Section/Fold Sequence** -- sets the section's position in the folding animation (left=early right=late). The number of valid stages is set by the **Folding Control/stages slider**, which is only visible when the *3D preview* is displayed.
9. **Active Section/Edit Offsets** – button which opens dialog box which allows the addition of an offset to the flap. See notes below for more details.
10. **Active Section/Edit Import** button is only made available when an imported section is made active. (see [12](#) - Clipboard & Imports)

Notes on Active Section

The image on the right shows 2 rectangles one on top of the other. The **bottom rectangle** is a flap that was added to the Base Line discussed earlier and the **top rectangle** was added to that flap.

These rectangles are also known as **sections**. These sections can only be edited one at a time, so it is important to know which one is the active one. The active section is always highlighted in light blue and the machine step points are a darker blue. The machine steps are denoted by the red lines. You can double left click or right click and select “[At Section](#)” on any section to make it active.

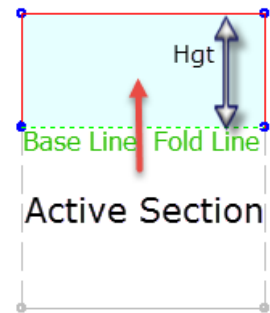

Properties for the Active Section shown →

Name field displays the section name which can be changed to something more meaningful if required.

Height field. NB: The height of all sections, other than the starting section, is measured from the green dotted base line protruding outward regardless of the position or direction the flap\panel is protruding.

Fold Angle will set the angle in degrees the flap\panel will fold in relation to its parent section. When the value for this control is set to 0deg the flap will not fold at all and will be in line with the parent section.

With the **Clockwise** checkbox, you can set the direction the flap\panel will fold. If checked the flap\panel will fold clockwise and unchecked for counter clockwise.

Scale Ht w Wth, if checked, will turn on the automatic scaling for the active section and cause its height to change in proportion to a change its width.

Fold Sequence slider control allows for 8 possible increments in a sequence. By moving the slider from left to right, you can set the step for current flap\panel to fold in the sequence.

Edit Offsets button is used for adding an offset to the flap. The offset is often used to subtract the thickness of the material you are using for the flaps to close. Click on the button to open the dialog, as shown right. From the **Configuration dropdown**, select how the offset will be applied e.g. Left, Right, Both etc. The applicable edit boxes will be made available to allow you to set the amount of the offset or use the checkbox to set the value to use the material thickness, in this example is 0.5mm, applied to Left.

11. **Active Point** lists properties of the current active point, if there is one. Points in the active section may be selected, as the active point, by left or right clicking the point, or by left or right clicking the line joining them to the next point in their machine step.

The active point is indicated by a "bullseye" , and the other end of the joining line is decorated with an arrowhead. The two editable fields display the local coordinates of the point within its section, and can be used to move it elsewhere. There is also a context menu command for this purpose: **Drag Point G** (which offers the additional ability to move the point using [global coordinates](#)).



Notes on Active Point

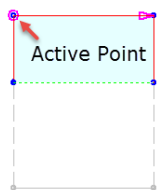

Right click on the Active Point  to bring up its context menu with a list of options and operations that can be performed on it.

The Machine **Step** field displays the name of the current shape you are working with, which in this example is "Flap".

Active Point			
Machine Step:Flap			Index:2
0mm	X - Locked to left	172.4mm	Y - Locked to top

The **Index** field shows the number of the active point e.g. "2". Points are numbered in a clockwise direction starting with the one attached to the left end of the hinge line and ending at the right end.

The next 2 boxes show the exact (x, y) position of the point *in relation* to the container section and their lock status.

If you left click and drag a box around the active point, or a group of points, the locking status will be shown by arrows.

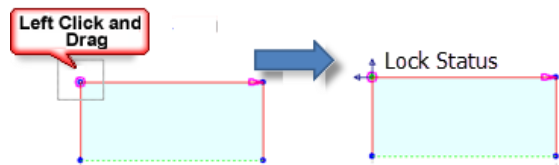

12. Clipboard & Imports

Although you can make your complete design from scratch, you can also incorporate some of the predesigned flaps or even copy a flap that you have designed into your project.

Clipboard & Imports	
Section Copied	Flap_1
Imported Section	DustFlap

The **Clipboard & Imports** properties lets you select a flap from our predesigned library to make it available to be imported into the active section using the right click context menu*. You can use the standard keyboard shortcut commands ctrl-C and ctrl-V to copy and paste flaps. When an imported section is made active an **Edit Import** button is only made available [See 10 – Active Section/Edit Import].

The **Section Copied** field displays the name of the section currently in the clipboard.

*See [Tutorial 107 Repeating Commands](#) - "Paste Clipboard Section" (or Ctrl-V) and "Paste Clipboard Subtree".

The following items are only visible if **Dimensions** is checked **AND** the **3D** preview is selected:

- **Folding control/Fold %** (slider and edit box) -- these change the location of the displayed box in the folding animation sequence from 0%=unfolded to 100%=fully-folded
- **Folding control/Play** -- toggles the animation between playing and stopped states
- **Folding control/Export 3D** -- opens a file save dialog for saving the 3D preview in various exchange formats

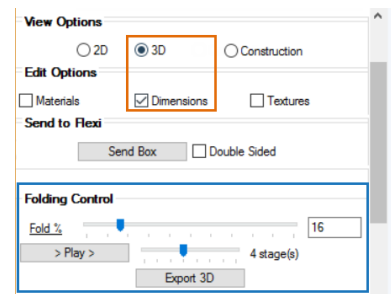

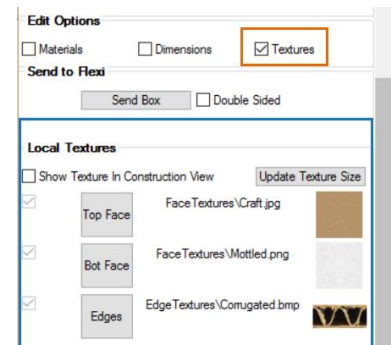

The following items are only visible if **Textures** is checked:

- **Local Textures/Show Texture** in Construction View -- check this if you need to align items with existing artwork
- **Local Textures/Top Face** -- never clickable in a Flexi-illustrated box
- **Local Textures/Bot Face** -- clickable if the Flexi illustration is one-sided - gives a dialog to choose the bottom texture
- **Local Textures/Edges** -- gives a dialog to choose the edge texture



Chapter 7: FreeForm - Create New Box/Display

On the Flexi toolbar, it is recommended that you click on the **lightning bolt**  button, which allows you to **use existing templates** which you quickly and easily modify to meet your requirements. [See [Chapter 1 – Create New Box/Display using Template](#)]

The option to **create your own templates** by using the **plus sign**  button but note that the design of a functional package or POS is quite intensive.

Using the New  button, plus sign, directly opens the BD (Box&Display) user interface called the Property Inspector, with the Friendly page and Preview panes as shown below.

[See [Chapter 6 – Construction Preview User Interface](#)]

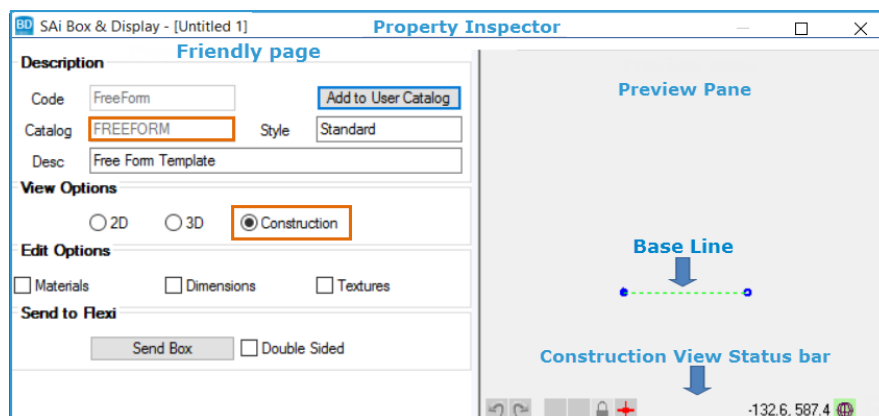

If the **Construction** preview option is chosen (as it is initially, shown above, the radio button on the Property Inspector, under View Options) then the window looks like this, with the box name **FreeForm**, (other previews are blank at this stage). At the bottom of the preview pane there is the **Construction View Status bar**.

If you decided to create your own template, you need to understand that boxes in Box&Display are constructed from...

- **Sections**, a tree-structured pattern, which are the conceptual parts which fold relative to each other (in 3D view).
- **Root** section anchors the whole structure.
- **Branch** sections connected to the root section and folding relative to it.
- **Sub-branches** connect to the branches, and
- **Leaves** connect to the sub-branches.

When you use templates, this structure is already constructed for you, but in Freeform you must construct it yourself.

Apart from the arbitrary choice of the root section, the requirement that the box is cut from a flat sheet of cardboard essentially determines the tree structure, so the construction process requires no design choices.

New sections generally attach to straight-line segments of the border of an existing section, overlaying the border segment with a **fold line** which is represented by a dashed line, and in production will be scored rather than cut. *In order to start the whole process, you need an initial **base line**, which is the sole purpose of the dashed line which appears when you start a new Freeform box* (as shown above).

Tutorial Video  [Make A Cardboard Cube.](#)

Step 1

Base Line Width

In **Construction View**, if you tick the **Dimensions** options, you will see that the default width of the Base Line is 300mm. Change this to 200mm.

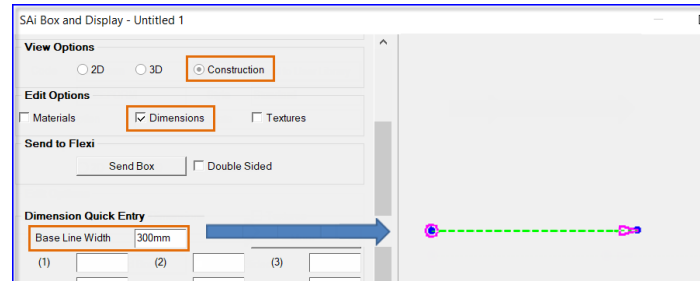

Add New Section

To add a new section...

- Right click on the 'Base Line' and choose **At Line > Add Basic Flap [L > F]** from the context menu.

[See [Chapter 5 Context Menu Options](#)]

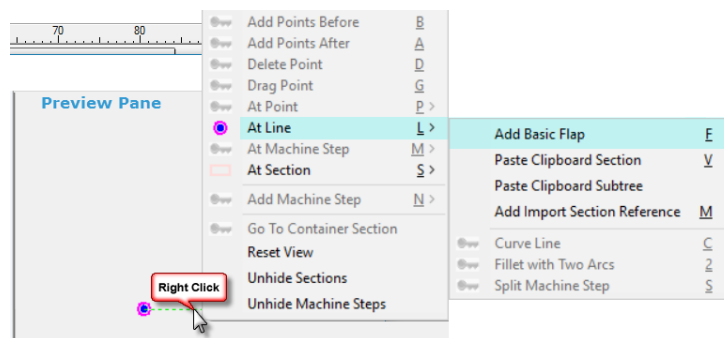

If you now left click, you will create an arbitrary or estimated dimension line when you **drag the rectangle** perpendicular to the base line. Note the Height [252.6] is stated in the status bar. **Left click** to complete process. NB: To abort the process, either <Escape> or right click.



- To provide an actual dimension, click the '**period**' key on your keyboard which will provide a **Section Height dialog** to allow you to enter a precise measurement.

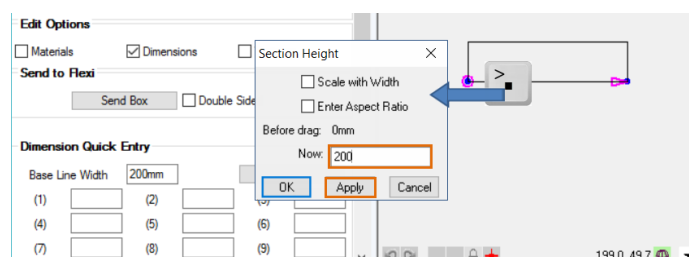

By repeating this action 5 times you can easily recreate the following picture:

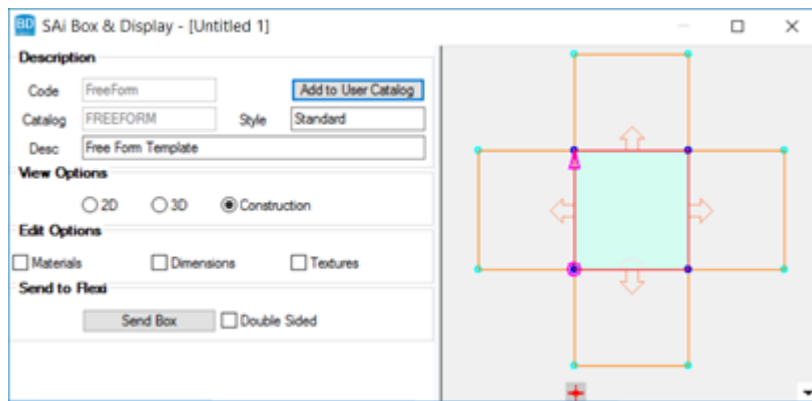

- To achieve *creating sections quicker*, put a number in the Quick Slots [shown below (1) 200mm]. Then **L > F** and hit **"1"** and hold down while you **left click** to complete.

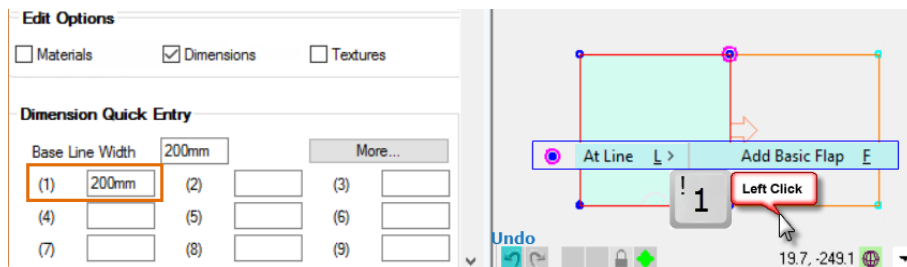

- Another way to achieve adding repeated sections is to **left click** on the base line and use **ctrl-R**. [See [list of repeatable commands](#) and [Tutorial 107](#)]. This will continue to add sections with the same dimensions until you achieve the result as shown in point 2 above.

If you make a mistake use **ctrl-Z** Undo and **ctrl-Y** Redo

3D Preview

Selecting the **3D preview** and then dragging the **Fold %** slider gives a rectangular sided box.

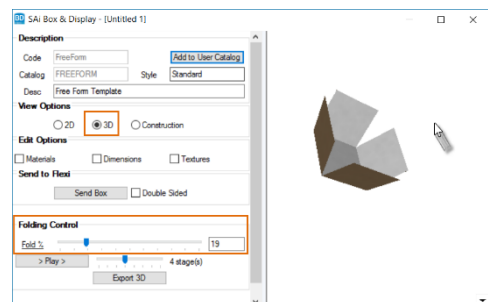

Step 2

Add a Lid

If we want to add a lid to the box, we need to add a new section to one of the lines near the edge of the drawing.

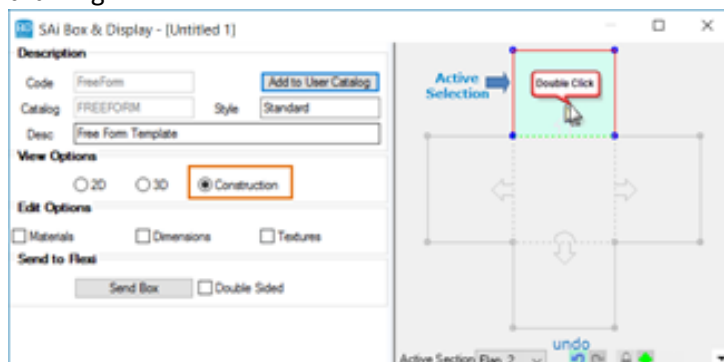

It is not possible, however, to select these lines by right clicking. (Construction view has an active or selected section, and it is only possible to select items which belong to that section).

To change the active section **double click inside the desired section**. The filled area of the active section is highlighted in blue-green, and its points and lines change colour.

Now add a new section to the top line of the picture, i.e. **left click** and **Ctrl + R**. Note that you may need to pan down to see your addition in the preview pane properly. [To pan using the mouse - simultaneously hold down the left and right mouse buttons and move the mouse in the direction you want to pan].

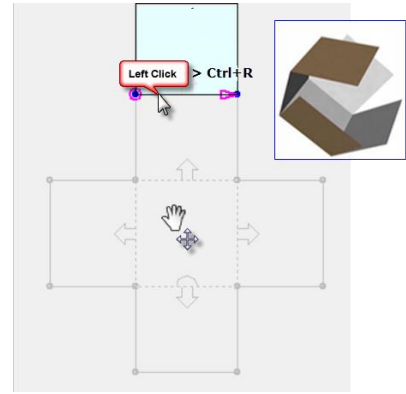

The inset shows the resulting box in 3D.

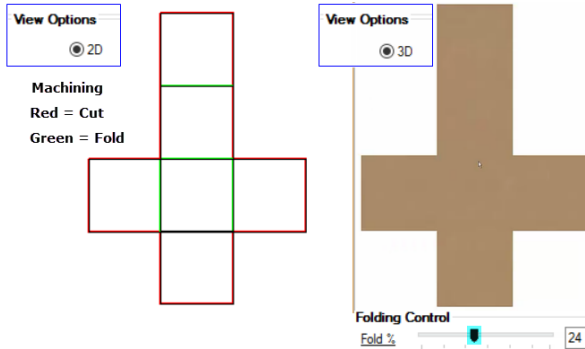

2D shows machining and 3D can be folded by using the Fold Slider.

Step 3

Illustrate Box with Flexi

Now we will illustrate the box. To do this we need to give Flexi the cutting instructions, which is a DXF in 2D line view with cutting and creasing instructions.

Follow numbers on the diagram...

1. **Send to Flexi** by clicking the **Send Box**.

Close the **BD** Property Inspector, using the top right X.

To **open/view** the BD use the eye  icon on the toolbar.

2. Select a **rectangle** from the Main Toolbar.
3. Click and drag to **select the design**.
4. Select a **swatch**, in this example we select **Rainbow**.

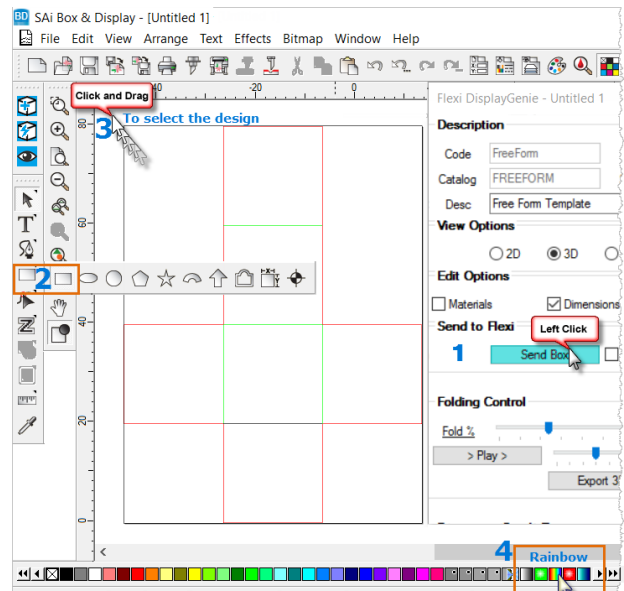

You will notice that the swatch now covers the design, so you will need to Send to Back.

- Click **Design Editor** on the Standard Toolbar.
- Select the **Objects** tab on the presented dialog
- Right click** on Layer for menu.
- Select **Order > To Back**.

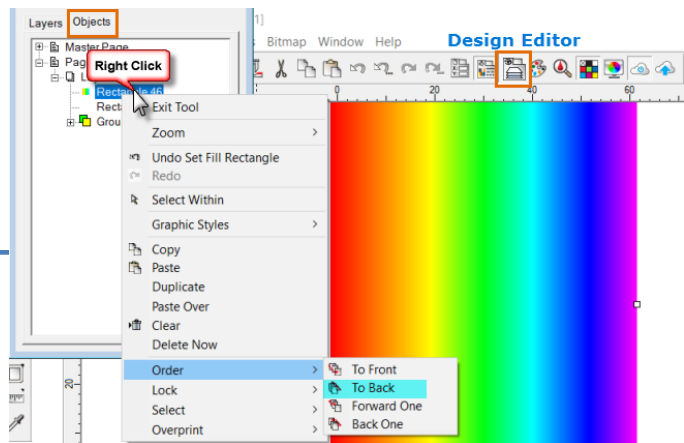

Now we will add rectangles and stars and allocate swatches.

- To set the **default colour** hold down **ctrl-Y** and then select a swatch.

Of course, you can also copy and paste the shapes.

The result.

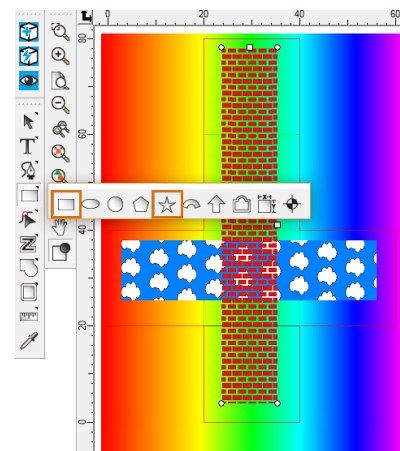
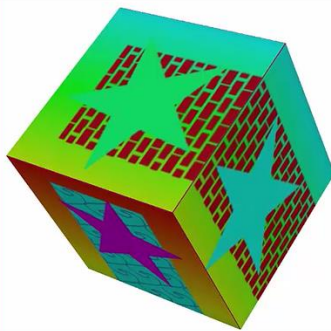
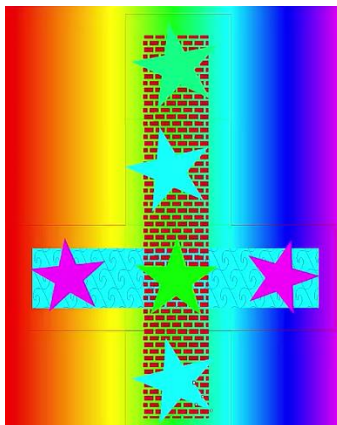

See [Tutorial 101](#) discussed at the end of this manual for more commands and their uses.

Step 4

Save File

In [Tutorial 103](#) we will use this design to learn more about adding flaps, so save your file for future use.

Use the **File > Save** or **Save As... 01+ cube** (note that the file extension will be **fs**)

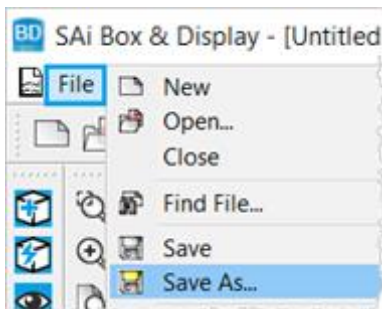

Chapter 8 Freeform Capabilities

Sections

Boxes in BD are constructed from a tree-structured pattern of *sections*, which are the conceptual parts which fold (in the 3D view) relative to each other.

There is a *root* section which anchors the whole structure, with *branch* sections connected to it and folding relative to it. Then *sub-branches* connect to the branches, and *leaves* to the sub-branches.

When you use templates, this structure is already constructed for you, but in Freeform you must construct it yourself.

The Freeform construction interface can perform the following operations on Sections: -

Command	Purpose
Copy Section to Clipboard	copies a section or section subtree
Paste Clipboard Section	pastes a copied section at a given line
Paste Clipboard Subtree	pastes a copied section subtree at a given line
Add Import Section Reference	attaches an instance of a standard library section or subtree
Delete Section	deletes a section which has no subsections
Delete All Subsections	deletes section subtrees from a given section
Delete Section & Subsections	deletes given section and its subtrees
Hide Section	temporarily hide a section (construction preview only)
Adjust Section Height	changes the height of a section (as measured perpendicular to its base fold)
Add Machine Step	see below for the kinds of machine steps which are available
Attach Hinge to Point	attach one end of section's base fold to a specified point in its parent section

Machine Steps

The Freeform construction interface can perform the following operations on Machine Steps (polygons which specify machining operations and the filled areas in Construction and 3D previews).

The available machine steps are:

- **Border** - sections are created with a border machine step, which is cut out in production
- **Markers** - sets of points for construction use (local to construction preview)
- **Hole** - internal hole (or cutout if it intersects the border)
- **Fold** - set of lines which are scored rather than cut in production
- **Perforation** - set of lines which are perforated rather than cut in production
- **Dimension** - specifies annotation with dimensions
- **Label Arrow** - specifies annotation with labelled arrows

Command	Purpose	Tutorial
Delete Machine Step	permanently delete machine step	
Hide Machine Step	temporarily hide a machine step (construction preview only)	
Open/Close Machine Step	toggle the open/closed property of the machine step polygon	
Select Machine Step Points	select all points in a machine step (for setting stretch modes)	
Mirror-complete Machine Step	append mirror-reversed copy of existing points (with respect to base fold midline)	106
Mirror-reverse Machine Step	mirror points with respect to base fold midline	
Convert to Flip-up	convert a perforation machine step to a flip-up	111
Round off Machine Step Corners	fillet all machine step corners	108
Format Machine Step	edit properties of annotation machine step	110

Tutorials – the following are located at the later in this manual.

- 106** Making Custom Flaps
- 108** Curves and Fillets
- 110** Annotation / Dimension
- 111** Making a Flip-Up

Machine Step Points

The Freeform construction interface can perform the following operations on individual Machine Step Points:

Command	Purpose
Add Points Before	add one or more points before the active point
Add Points After	add one or more points after the active point
Delete Point	delete the active point (or the whole Machine Step if it only has one point)
Drag Point	drag the active point to a new position
Chamfer corner	replace a corner point with a diagonal line
Fillet corner	replace a corner point with a circular arc
Adjust Two Arc Corner	fix the smooth tangent fit of a two arc corner after the adjacent lines were changed

There are also several commands which are generalisations of Machine Step Line commands to the conceptual lines joining any 2 points in the active section.

1. The active point is used as the first of the 2 points.
2. The command operation starts with a rubber band which allows you to select the second point.
3. After you select the second point with a left click the procedure continues in the same way as the related **At Line** command.

Command	Purpose
Add Basic Flap	attach a new rectangular section to the line
Add Clipboard Section	attach a copy of the clipboard section to the line
Add Clipboard Subtree	attach a copy of the clipboard section and its subtrees to the line
Add Import Section Reference	attach an imported instance of the section or subtree selected in Clipboard & Imports /Section

Machine Step Lines

The Freeform construction interface can perform the following operations on individual Machine Step Lines:

Command	Purpose	Tutorial
Add Basic Flap	attach a simple rectangular section to the line	
Add Clipboard Section	attach a copy of the clipboard section to the line	
Add Clipboard Subtree	attach a copy of clipboard section and its subtrees to the line	
Add Import Section Reference	attach imported section as per Clipboard & Imports/Section in BD Property Inspector	
Curve Line	convert a line into a circular arc , or adjust the curvature of an existing arc	*
Fillet with Two Arcs	convert the line into 2 arcs with smooth connections	*
Split Machine Step	break the machine step at a new point located on active line	**
Add Tab or Notch	attach a rectangular tab or notch to the line	**
Add Slot	insert a rectangular slot inside active section	**
Add Circle or Oval Slot	insert a circular slot inside active section	**



* **Tutorial Video**  [Curves and Fillets](#)

** **See [Tutorial 113](#)** – Add Tab, Notch, Slot (after splitting a machine step)

Modal Cursors

Commands may be divided into "immediate" and "modal".

- Immediate commands are completed when you click in the context menu.
- Modal commands put the mouse into a special state and require a user input to complete (generally moving the mouse to a location and left clicking). Modal commands may be aborted using Escape or right click. In some modal states the mouse uses the normal arrow cursor. In these cases, the modal state is evident from the presence of a rubber band line or a drag rectangle.

Name	Picture	Meaning
Standard Arrow		No selectable point nearby
Cross		Selectable point nearby
Diagonal Cross		Choosing an exact spatial location (accuracy needed unless snap is active)

Modal Command Procedures

- Add Basic Flap,
- Copy Section to Clipboard,
- Paste Clipboard Section,
- Paste Clipboard Subtree,
- Add Import Section Reference

If using the **At Point** variant, the active point becomes the start point of a rubber band line. Move the cursor near another point in the active section. Left click when the cursor changes to a cross.

Both **At Point** and **At Line** variants:

- Move the mouse perpendicular to the baseline to drag the rectangle which tracks the new section's height. The current numeric value is displayed at the bottom right of the pane. Use the 1 to 9 digit hotkeys to lock the height to a **Dimension Quick Entry** value (you can still move the mouse to select which side of the baseline the section is attached to). Left click to use the current height.
-
- While dragging the rectangle, you can press 'period / full stop'  key to open a numeric entry dialog for setting the section height exactly.
 - Some import sections have border machine steps which depend on the section height in unexpected ways or not at all. In these cases, the image of the new section may follow the drag rectangle in an unusual fashion.

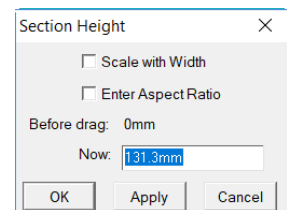

Adjust Section Height

Move the mouse perpendicular to the baseline to drag the rectangle which tracks the section's new height. The current numeric value is displayed at the bottom right of the pane. Left click to use the current height.

The 1 to 9 and 'full stop' hotkeys may be used in the same way as for **Add Basic Flap**.

Add Machine Step

It is irrelevant where you right click to open the context menu when adding a machine step.

After choosing the machine step type from the submenu, the [cursor changes](#) to a diagonal cross ✕ for choosing the location of the first point.

- Left click to choose a point, or press 'period / full stop'  key to enter the coordinates numerically (in either global or section-local coordinates).
- Cancelling out of the numeric dialog ends the command, otherwise the cursor remains a diagonal cross and you can choose another point.
- For points, other than the first, the cursor is connected to the previous point by a rubber band line.

To terminate the command, use **Escape** or **right click**. Points which you have already left clicked are not erased by terminating.

If you move the cursor over the first point of the machine step it changes to an ordinary cross and left clicking will close the machine step and terminate the command.

Zooming in sufficiently should allow you to add a point near the endpoint without snapping.

The Dimension machine step differs from usual in that the first machine step point is not visible. However, it still serves as the start of a rubber band line, so its position is nevertheless apparent.

Drag Point

The selected point tracks the cursor, and can be fixed in a new location by left clicking.

While dragging the point, you can press 'full stop'  to open a numeric entry dialog for setting the location exactly.

Dragged points are subject to the current snapping modes. If you move the cursor near a snapping target, then the dragged point will jump there (note the cursor itself does not snap).

Add Points Before, Add Points After

A [new point is added](#) before or after the selected point and then tracks the cursor, and can be fixed in a new location by right clicking. After right clicking an additional new point is created, and can likewise be dragged.

Terminate the command with **escape** key. A newly added but unpositioned point will be deleted.

The dragged point is subject to the current **snapping** modes. If you move the cursor near a snapping target, then the dragged point will jump there (note the cursor itself does not snap).

While dragging the point, you can press 'period / full stop'  key to open a numeric entry dialog for setting the location exactly. Cancelling out of the numeric dialog terminates the command, otherwise a further new point is created and can be dragged.

Attach Hinge to Point

This advanced command is chiefly used for repairing sections which have been detached from their anchor points in their parent section (for example, if one or both of the anchor points is deleted). Such repair is unnecessary unless the child section is scaling incorrectly.

Select the child section. Right click close to one or other end of the child section baseline, as this determines which anchor point is affected.

The active section changes to the parent section. Move the cursor near a machine step point in that section, and it should change to a cross.

Left click to select the point. The child section baseline and the entire child section will change to reflect the new anchor point.

Curve Line

Move the cursor perpendicular to the baseline to drag a rectangle which contains the arc. Left click to select the current curvature. See [Tutorial 106](#)

If you drag the rectangle far enough the arc will stop responding, since arcs exceeding a semicircle are not supported. However, this is an easy way to get an exact semicircle.

While dragging the rectangle, you can press 'full stop' to open a numeric entry dialog for setting the curvature exactly. The value 1.0 represents a semicircle, and 0.0 is a straight line. In addition, there are buttons which set the curvature so that one or other of the adjacent lines is a tangent to the curve

Tutorial Video [Curves and Fillets](#)

Note that in order to select a Machine Step Line drawn as an arc you must click near the chord (the line connecting the 2 endpoints) rather than on the visible arc.

Chamfer corner, Fillet corner

The corner point converts to 2 points joined by a diagonal line or circular arc. Move the cursor perpendicular to the diagonal line or arc to choose the amount of chamfer or fillet. Left click to select the current value.

During this process, you can press 'full stop'  to open a dialog for selecting the chamfer or fillet amount numerically. The numeric value is the distance from the original corner to each of the new points.

Also, you can hold one of the 1 to 9 digit [hotkeys](#) to snap the chamfer or fillet amount to a **Dimension Quick Entry** value.

Since chamfering and filleting destroy the original corner point the chamfer or fillet amount cannot be adjusted after the command is terminated (except by undoing the command).

Split Machine Step

This command breaks a machine step at a point on the active line. Two new points are added, creating a small gap, which is constrained to move along the active line as you move the mouse. Left click to complete the current command.

Numeric entry is available by pressing 'full stop'  key which [opens a Precision Input dialog](#).

If the machine step was originally closed, then it is now open and these 2 points are its endpoints. If the machine step was open, then splitting creates 2 machine steps, and the 2 new points are each an endpoint of one of the new machine steps.

Add Tab or Notch

This command creates a tab or a notch which can be repositioned by moving the cursor up or down the active line or accurate measurements can be entered via a dialog. Subsequent tabs/notches will be reproduced with the same height and width until changed or the current BD session is terminated.

A tab is created when the height measurement is a positive number. A notch is created simply by changing the height measurement to a negative number.

Numeric entry is available by pressing 'full stop'  key which [opens a Precision Input dialog](#).

Add Slot

This command creates a rectangular slot which can be repositioned by moving the cursor up or down the active line or accurate measurements can be entered via a dialog.

Edit boxes that control the **inner/outer/center** line offsets are provided in addition to the height measurement. Like the 'Tab/Notch' width, height and offsets are remembered i.e. every subsequent slot created will be reproduced in this manner until either measurement is changed or the current BD session is terminated.

Note: These offsets all interact. It creates the extra Hole machinestep and puts it in the "-Cut" layer (or uses whatever you specify as `_mscutlayer`).

Numeric entry is available by pressing 'full stop'  key which [opens a Precision Input dialog](#)

Add Circle or Oval Slot

This command creates a circular or oval slot in exactly the same manner as creating rectangular slots discussed above. Slots can be repositioned by moving the cursor up or down the active line or accurate measurements can be entered via a dialog.

Numeric entry is available by pressing 'full stop'  key which [opens a Precision Input dialog](#)

Tutorial Videos

The following is a list of the available videos, which have been referenced throughout this manual and can be accessed at <http://www.printtocut.com/>

Box and Display Getting Started Videos

To help you to quickly create your own design from scratch, the following videos discuss ...

- the interface/friendly page options
- context menus used in Construction View
- creating and folding a box

[Getting Started Videos](#)

1. Starting a New Project
2. Edit Materials
3. Edit Dimensions
4. Edit Flaps & Panels
5. Advance Flap Settings
6. Local Textures
7. 3D View Controls
8. Send Box to Flexi
9. Convert to allow changes to template

[Freeform Interface & Basics Videos](#)

1. Quick Entry Dims
2. Active Section
3. Active Point
4. Clipboard & Imports
5. Add Flap & Points
6. Delete-Drag-Undo-Redo of Point
7. Chamfer Fillet & Adj 2 Corners at Point
8. Tutorial 101 – Create New Box
9. Tutorial 102 – Fold Sequence

[Advanced Freeform Video](#)

Watch how to create Pen Holder Display with slots, holes, notches and tabs in a 7 part video tutorial. See also [Tutorial 113](#) in this manual.

You may also like to watch



[How to Create a Corrugated POP Display in Seconds Using BD](#)

OR copy address to your browser: <https://www.youtube.com/watch?v=GbRLKmuuSH4>



Tutorial Videos

[More Freeform Videos link](#)

The following are list of FreeForm tutorial videos that begin with the creation of a simple cube and then build on this to discuss more complex capabilities.

Step by step instructions can be found in the related Chapters/Tutorials of this User Guide.

1. Make A Cardboard Cube – [See Chapter 7](#)
2. Add Flaps and Glue Tabs – [See Tutorial 103](#)
3. Simple Scale Propagation – [See Tutorial 104](#)
4. Parametric Scaling – [See Tutorial 105](#)
5. Making Custom Flaps – [See Tutorial 106](#)
6. Repeating Commands using ctrl-R – [See Tutorial 107](#)
7. Curves and Fillets – [See Tutorial 108](#)
8. Importing pre-designed flaps – [See Tutorial 109](#)
9. Annotation using Dimension and Arrow – [See Tutorial 110](#)
10. Making a Flip-Up – [See Tutorial 111](#)
11. Rivet Holes – [See Tutorial 112](#)

[Templates – How To Videos](#)

Since the design of a functional package or POS is quite intensive, it is recommend using and modifying existing templates. Use the link above to see how easily templates can be modified.

Relating step by step instructions can be found in the User Guide (links below).

- X017 Clinton FSU (Point of Sale display) – [See Tutorial 201](#)
- Sloped Shelf Display [F SSD] Features (Point of Sale display) – [See Tutorial 203](#)
- DXF CutOuts1 [Swan] and CutOuts2 [convert to Rocking Horse] – [See Tutorial 204](#)
- CounterTop and Flip Up – CL-FL-300 [folding demo] (Point of Sale display) – [See Tutorial 205](#)
- Super Hero Flip Up – CL-FL-300-2 (Point of Sale / Countertop display) – [See Tutorial 205](#)
- Modern Shelf (Furnishing) – [See Tutorial 206](#)
- X063 Dillon Table (Furnishing) – [See Tutorial 207](#)
- X101 Giraffar FSU (Point of Sale display) – [See Tutorial 207](#)
- X106 Loxo Standee (Signage display) – [See Tutorial 207](#)
- X132 Cocktail Table - Plus (Furnishing) – [See Tutorial 207](#)
- The Cube (Utility Item)
- Box Inserts - – [See Tutorial 208](#)

[Box Wizard](#) can be used to create your own templates and is the perfect tool for quickly designing one off and small runs of boxes and shipping cartons. It is fast and easy to use with a very intuitive interface.

FreeForm Tutorial 101 – Create New Box

In this tutorial, you will learn how to create a small carton or box from scratch.

Tutorial Video  [SAi Box and Display Tutorial 101](#)

Step 1

Start by Creating a Box&Display project

- From the Flexi tool bar, select **New** 
- It takes a moment for the project to load.



Step 2

Starting your design

- Click on the **Dimensions** check box
- **Set Dimensions**
Change the Base Line Width from 300mm (default) to **200mm**

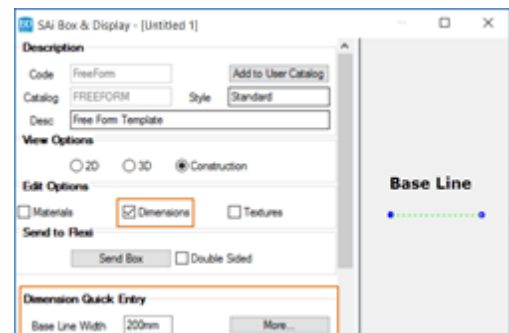

Step 3

Create Main Panel – Basic Flap

Note: Flap and Panel are synonymous terms in the construction view

- **Right click** on the **Base Line** to bring up the context menu, as shown.
- Press the **L** key for Line to open the fly out menu
- Press the **F** key for Flap
- Press the **“full stop”** key to open the Section Height dialog
- and type in **300**

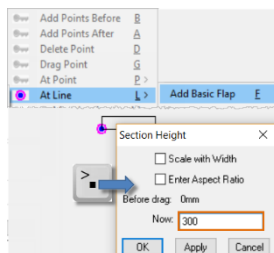

This will result in the following

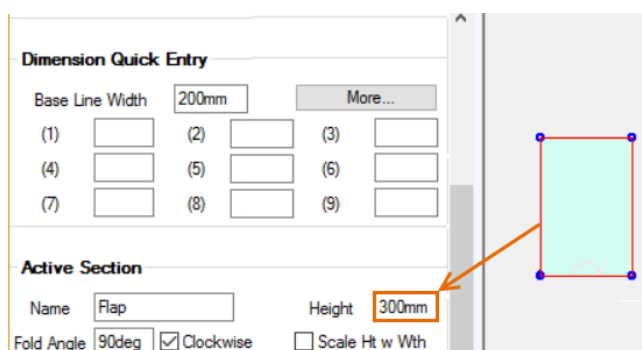

Step 4**Dimension Quick Entry**

In the [Dimension Quick Entry](#) boxes enter in following dimensions for use in building our box (1) **125mm**, (2) **200mm**, (3) **50mm**

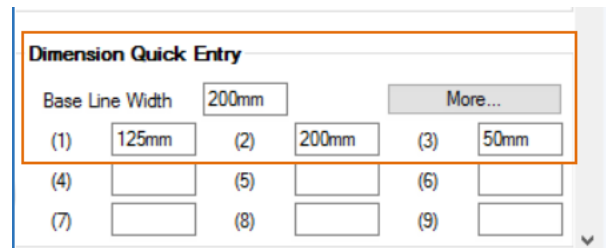
**Step 5****Add a Second Panel**

1. **Right click** on the right hand side line to bring up the [context menu](#)
2. Press the **L** key for Line to open the fly out menu
3. Press the **F** key for Flap
4. Hold down the **"1"** key and move your **mouse up** from the selected line and **Left click**.

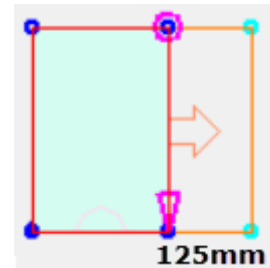
**Step 6****Adding More Panels**

- Double left click on the newly created panel to select it. (Note the color change to light blue).
- Using the methods learned in Step 5, create two more panels to the right of the previous ones.

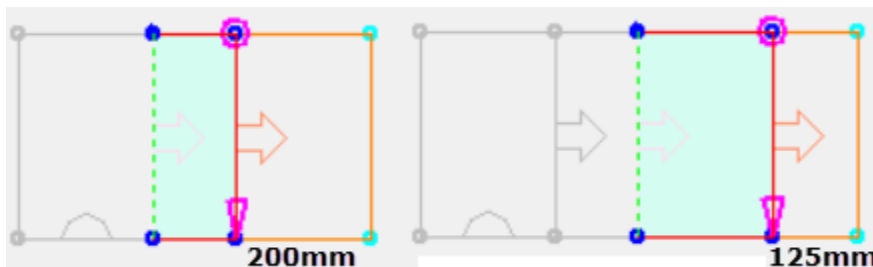

- Use **dimension (2)** for the next panel and **dimension (1)** for the final panel.
- These 4 panels form the sides of your box.

Note: If you make a mistake and need to **Delete a Section**, select section (highlighted blue) and from the context menu, press **S** and then **D**.

OR use **ctrl-Z** Undo and **ctrl-Y** Redo

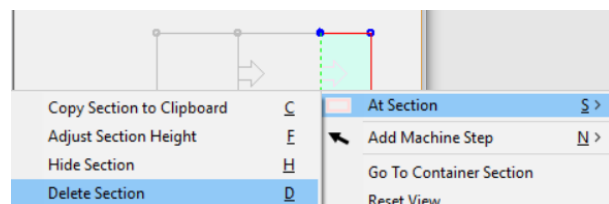
**Step 7****Adding Lid Flap to Main Panel**

- **Double left click** on the Main Panel
- **Right click** on the line at the **Top edge** of the main section to bring up the context menu
- Press the **L** key for Line to open the fly out menu
- Press the **F** key for Flap
- Hold down the **"1"** key and move your mouse above the selected line and **Left Click**.

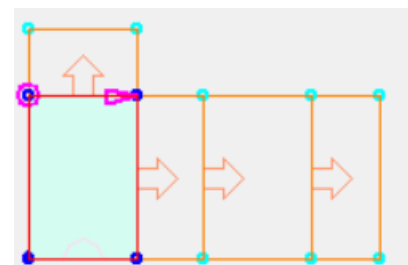

Before proceeding with Step 8, we need to **reduce the Height** of the Lid Flap from 125mm to 124mm.

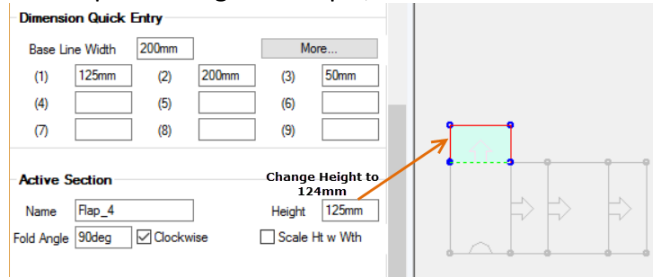

Step 8

Adding Tuck Flap to Lid Flap

- **Double left** click on the Lid Flap added in Step 7
- **Right click** on the line at the Top edge of the flap you just added
- Press the **L** key for Line to open the fly out menu
- Press the **F** key for Flap
- Hold down the **“3”** key and move your mouse above the selected line and **Left Click**.

Step 9

Fillet Flap Corners

- Right click on the point in the top left corner of the flap you just created.
- Press the **P** key for Point to open the fly out menu.
- Press the **R** key for Round
- Hold down **left mouse** button and **drag** to set the size of the **fillet** and **let go** of the mouse button.

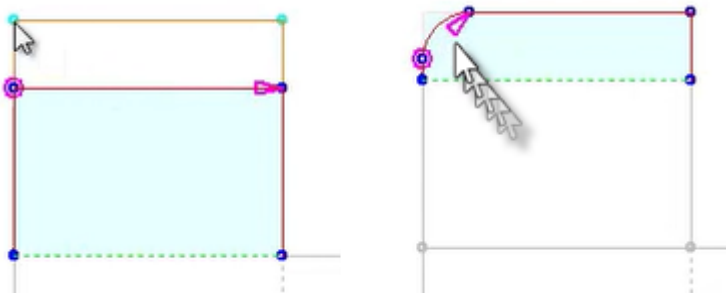
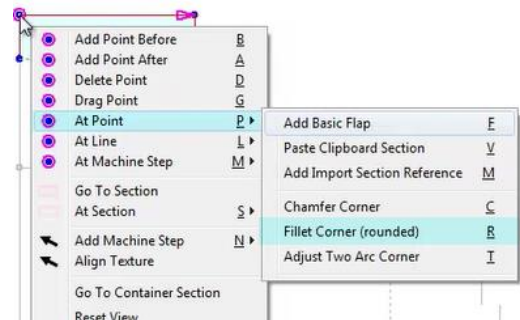

- Left click on the **right top point**
- Press **ctrl - R** to repeat the command. This will create the exact same radius on the right as previously created on the left.

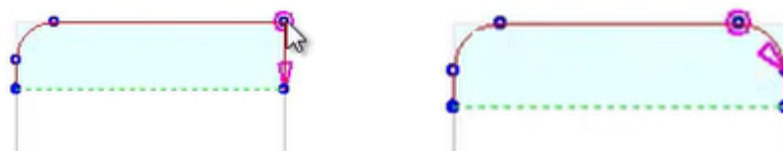

To ensure that the box will close well, we need to add an 0.8mm gap on either side to.

- Click on the **Edit Offsets** button to open **Override Offsets Properties** dialog
- Select **(4) Left/Right** from the Configuration dropdown
- Enter in **0.8mm** in both edit boxes as shown and click 'OK' to save and close.

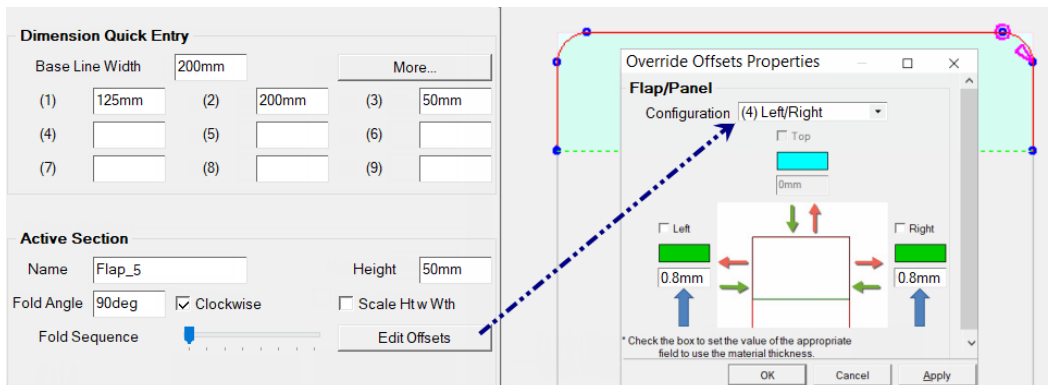

Step 10

Create Dust flap

- Double left click on the panel **left of the Main Panel**
- Use shortcut keys **L > F** to add a flap.
- Drag flap to size, manually, above the panel
- Look at the task bar coordinates in the bottom right corner of the preview pane to set the length of the flap to about 75mm. It does not have to be exact, as shown here it is 75.7.

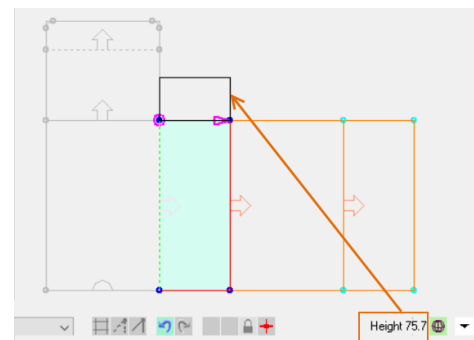

Step 11

Adding a Glue Flap and Chamfer Corner

- Select the **Main Panel** and right click on the line at the **left edge**
- Using one of the methods learned earlier add a flap and set its width to be 50mm
- Use the at Point **P** option to **chamfer C** the outside corners to 35mm

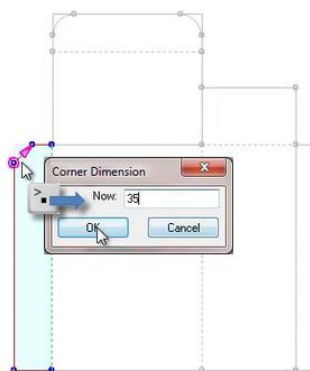
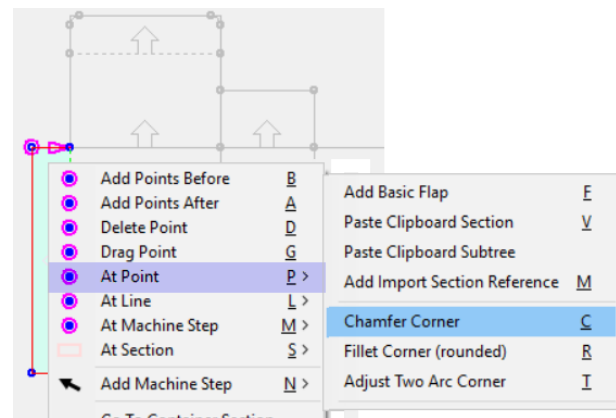

As in Step 9, to create Fillet, click and drag on **top point**, as shown. If you hit the "full stop" key, you will be presented with a dialog box where you can enter the Corner Dimension of 35mm. Note: Measurement is not the length of the chamfer but the distance across as shown.

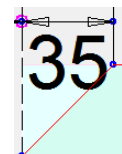

Then point on the **bottom point**, left click and ctrl-R to repeat the chamfer. You will be presented with the Corner Dimension dialog and you can click 'OK' to 35mm.

Tutorial Video [Chamfer Fillet&Adj 2Corners at Point](#)

Step 12

Copy/Paste Flaps

1. Double left click on the Lid Flap (1) section at the top of the main panel.

Press **ctrl -C** to copy this flap

Double click on the section that you want to add the flap to, to make Active i.e. will turn light blue.

Left click on the line you want to paste the flap to and press **ctrl -V** to paste the flaps (1)

2. Repeat for Tuck Flap (2) paste as shown (2)

3. Repeat for Dust Flap (3) paste as shown (3) three times, as shown.

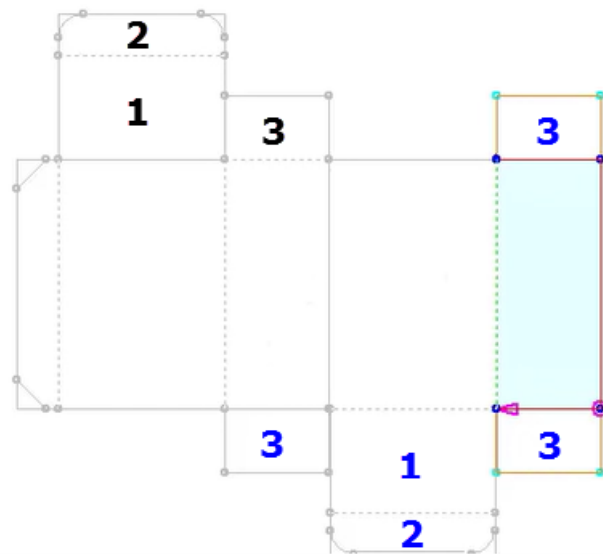

The following shows the completed box in 2D view.

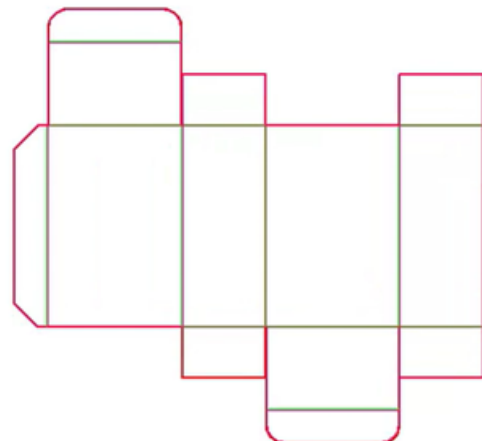

Step 13

Send to Flexi and Save File

The next tutorial will use this design, so save your file for future use.

To do this first "Send to Flexi" by using the **Send Box** button. You can now close the BD Property Inspector.

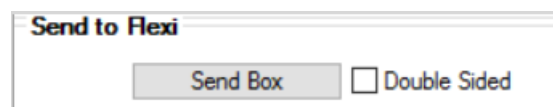

Then use the **File > Save** or **Save As...** Tutorial 101
Note that the file extension will be **fs**

FreeForm Tutorial 102 – Fold Sequence

In this tutorial, you will learn how setup the fold sequence, take our design in and out of Flexi Sign Pro and then fold our finished box in Box&Display.

Tutorial Video  [SAi Box and Display Tutorial 102](#)

Step 1

View in SAi Box Display

- **Open tutorial 101** that we saved in the previous tutorial
- Use the “eye”  button to **View in SAi Box Display**

Here is the box we created in Tutorial 101. The sections have been numbered as we are going to learn how to get the box to fold in sequence.

Sequence

If we use the Folding Control, *without setting a sequence*, then the box will fold simultaneously (as shown). Since we want to watch the sections fold, we need to set the sequence for the fold.

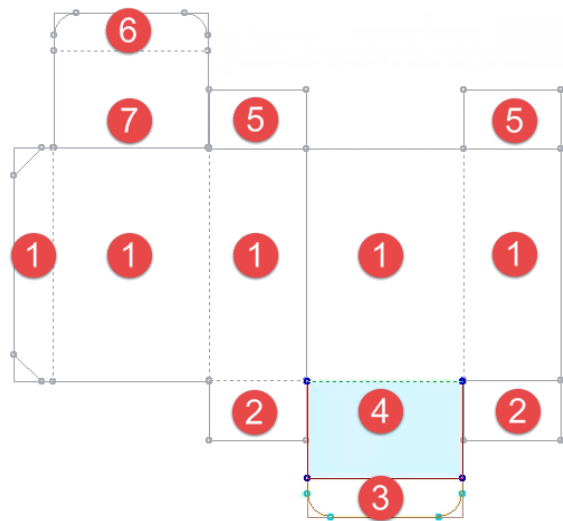
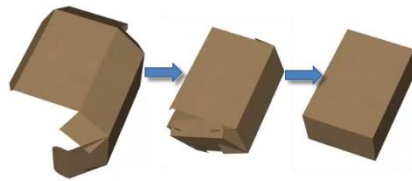

Step 2

Setting the Stages Slider

- Change the View Option to **3D**
- Set the Stages **slider to 7** by sliding the pointer, as shown, to the seventh mark. The comment should state ‘7 stage(s)’

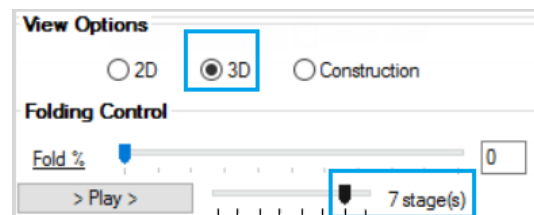

Step 3

Setting the Fold Sequence

- Change the View Option to **Construction**
- We are now going to select each box Section individually and assign a Fold Sequence number. We will number the Main Panels to fold 1st and then the bottom Dust Flaps 2nd and so forth.
- Double left click on **each of the sections one at a time** and set the **Fold Sequence** slider the number of ticks from the left to correspond to the number in image Step 1.

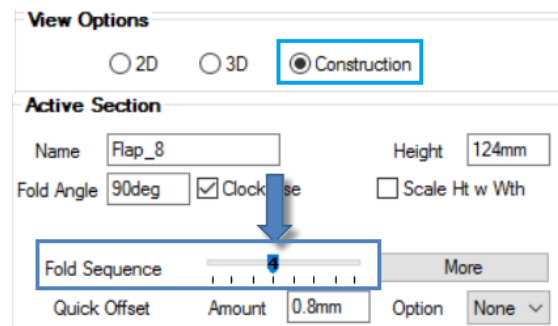

Image in Step 1 shows an **Active Section** (highlighted in blue) with the **number 4** allocated. The *image in Step 3* shows the **Fold Sequence** marker set at 4th tick.

Step 4

Illustrate Box with Flexi

Now we will illustrate the box. To do this we need to give Flexi the cutting instructions, which is a DXF in 2D line view with cutting and creasing instructions.

1. **Send to Flexi** by clicking the **Send Box**.

Close the BD Property Inspector, using the top right X or minimize.

2. You can create your own design (see Chapter 7) or **Import** using the  on the Standard Toolbar artwork.
3. Here we have imported artwork and added some stars.

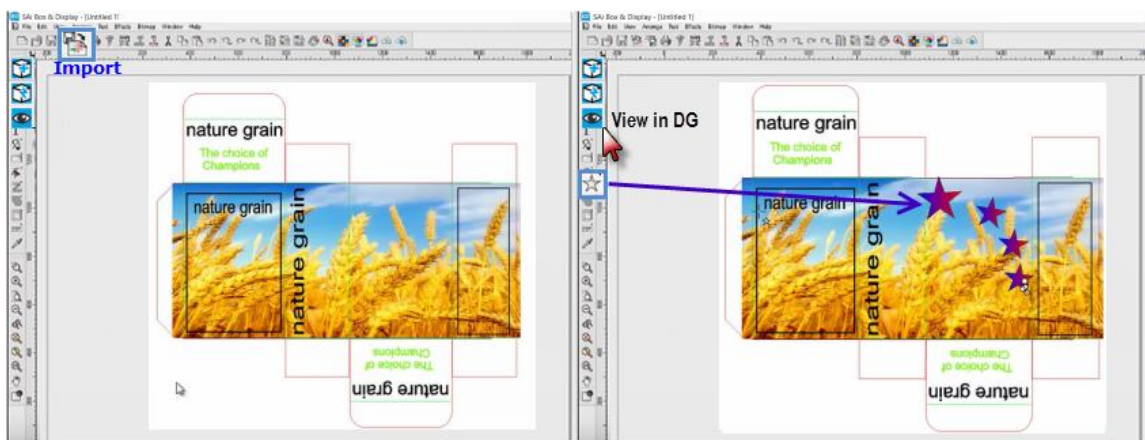

Step 5

View in SAi Box Display

- Then click on the eye  icon to 'View in SAi Box Display'.
- You will see the resulting placement of artwork using the 3D View Option.

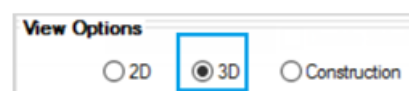

Step 6

Fold and Position Illustrated Box

- In the Properties window, Folding Control, as shown below, move the **Fold %** slider to the right to fold.
- Notice that the Main Sections that we previously set **Fold Sequence** to '1' folds first.



Then the Dust Flaps (set to Fold Sequence '2') will fold. Then Fold Sequence 3 to 7.

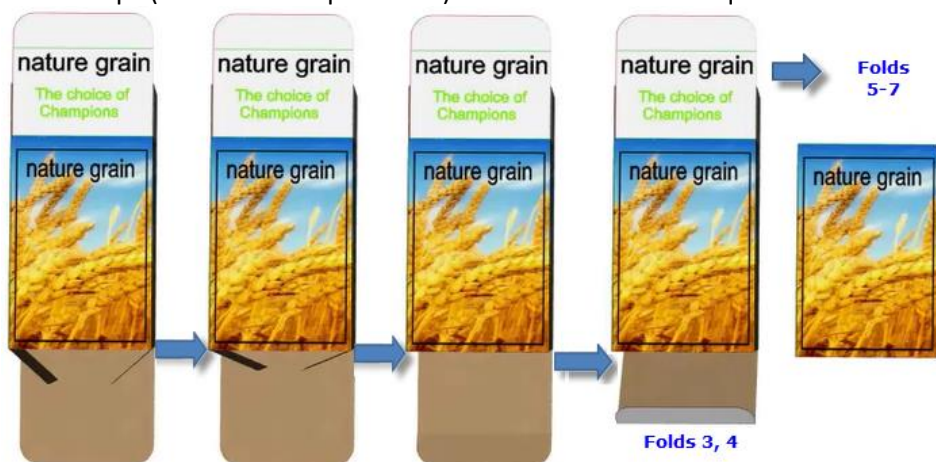

Step 7

Preview Pane Focus and Navigation

Move the mouse cursor to the preview pane and left click. This moves the mouse focus to the preview pane. Navigate the 3D box with the following mouse movements. In 3D preview...

- **Pan:** Hold Left and Right mouse buttons and drag to pan in any direction.
- **Zoom:** Use mouse wheel to zoom (◆) or Right click, hold and move mouse up & down on the screen
◆ if necessary left click on the pane first to get mouse and keyboard focus.

- **Rotate:** Left click and drag to rotate the image (in centre to rotate out of the viewing pane, around the edge to rotate in the viewing pane)



See the end of **Tutorial 103** for more on [Fold Sequence](#).

Send to Flexi and Save File

The next tutorial will use this design, so save your file for future use.

FreeForm Tutorial 103 - Add Flaps and Glue tabs

In this tutorial, we will add Glue Flaps and Folding Flaps to the cardboard box created in Chapter 7.

Tutorial Video  [Add Flaps and Glue Tabs](#)

Step 1

View in Sai Box and Display

- Open **01+ cube.fs** that we saved in the Chapter 5 of this manual (or open from [website](#))
- Use the “eye”  button to **View in SAi Box Display**

Step 2

Add Glue tab – Section Height dialog

- Select Construction view
- Double click on far left section to make ‘Active’ as shown (highlighted in blue)
- Right click on the top line and choose **At Line > Add Basic Flap [L > F]** from the context menu.
- Use ‘period’ key to open Section Height dialog and enter in 8mm and hit OK. See image right for result.

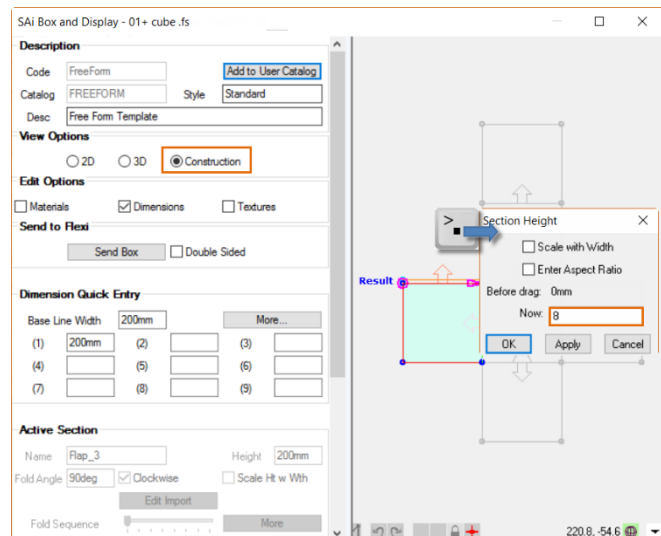

Step 3

Change Active Point Length

We are now going to Chamfer the Glue tab by changing the Active Point length.

- To change the **LHS Active Point**, left click on the Point, which as shown below left is initially 0mm.
- In the Edit box change this to **5mm**. You will see the Active Point move 5mm right as shown below right.

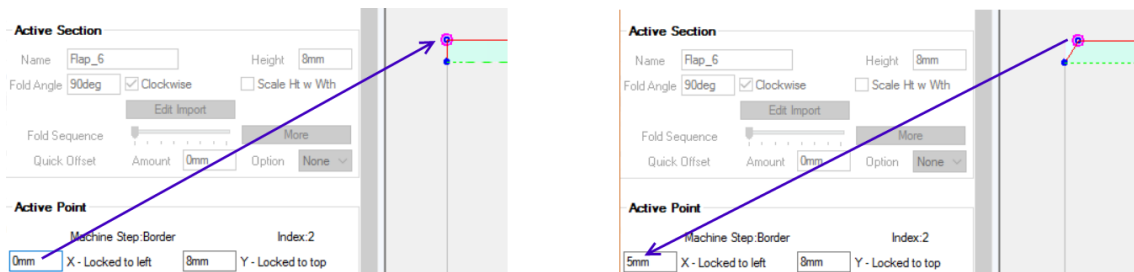

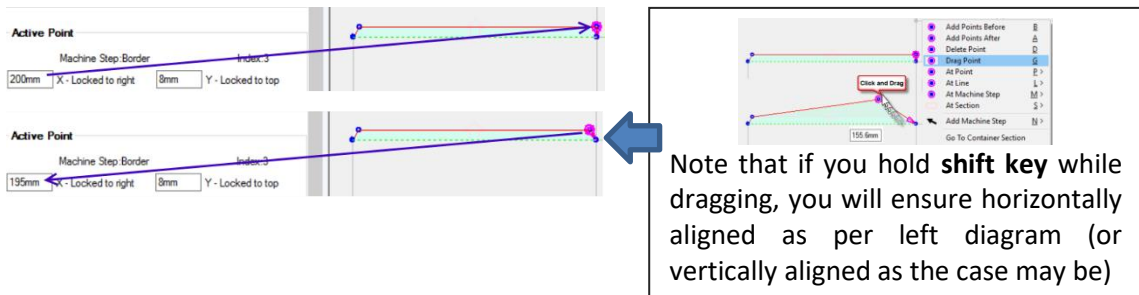

- We want to change the **RHS Active Point** (left click on) as shown below from 200mm to **195mm** by changing the **length in edit box** as shown below left OR by using the **Drag Point** command from context menu (right click) as shown below right (i.e. click and drag point)



Notes on Alignment and Snap to Grid

As noted in the text box on previous page, holding down the shift key while dragging a point will ensure that line is aligned, either horizontally or vertically.

In the image, you can see that the line is too high. Snap to Grid  will correct this and create a horizontal line.

- **Right click** on  icon to open **Grid Spacing** dialog, as shown, and change from 5mm (shown below left) to 1mm (shown below right) to help with aligning.

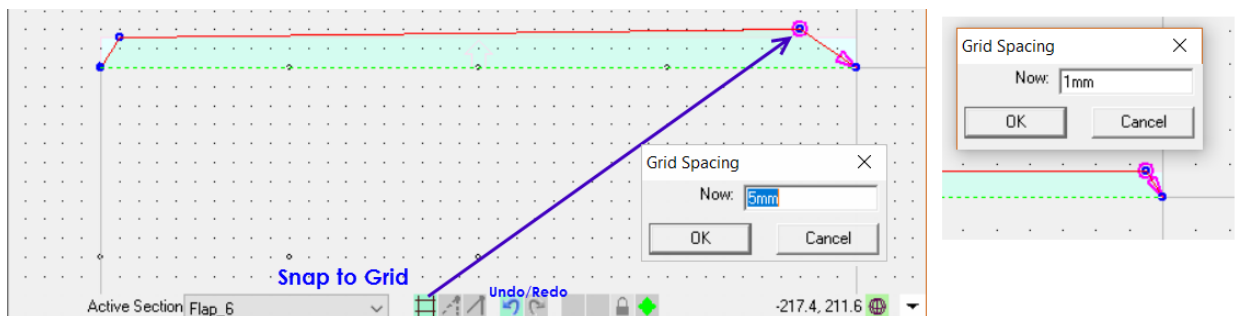

Step 4

Copy Section to Clipboard and Paste

Now we will **copy** the section using the context menu

- Double left click on the Glue flap you just created, to make Active Section.
- Right click to get context menu
- Press the **S** key for At Section to open the fly out menu.
- Press the **C** key for Copy Section to Clipboard

Now we will **paste** a copy of the Glue flap to the bottom of the Main section

- Double left click on the Main flap, shown below right highlighted i.e. Active Section
- Left click on bottom line, to make Line Active
- Use **ctrl-V** to paste

Result shown right.

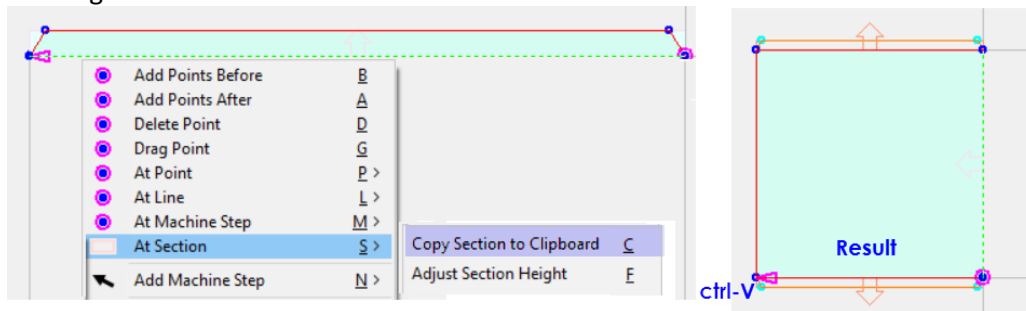

Now repeat the paste to panel on right of Main Section as shown.

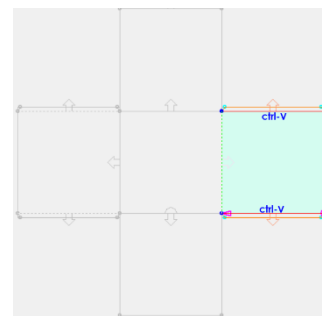

Step 5

Add Flaps and Chamfer

Now add 50mm flaps

- Double left click on the **left** panel
- Use shortcut keys **L > F** to add flap
- Use **'period' key** to open Section Height dialog and set to **50**, as shown.

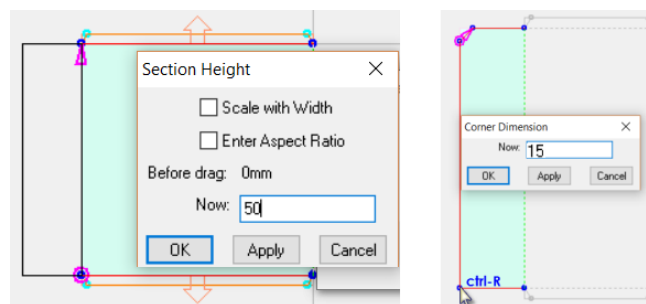

Chamfer to 15mm

- Double left click on the panel flap created above
- Use shortcut keys **P > C** to Chamfer
- Use **'period' key** to open Corner Dimension dialog and set to **15**, as shown above right.

Copy this to the other side and top as shown →

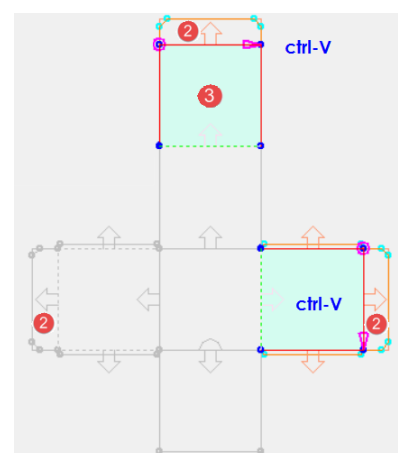

Step 6

Fold Sequence

As discussed in [Tutorial 102](#), if you don't set a fold sequence your box will close simultaneously.

Set a simple fold sequence by double click on all three **50mm flaps** just created, one at a time and set Fold Sequence to **2** as shown below.

And then double click on the **top flap**, as per image above right, and set to Fold Sequence **3**.

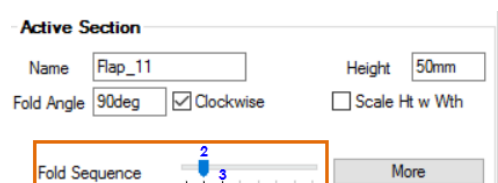

Folding Control

The Folding Controls are only available when you are in the 3D view. Use the **Amount slider** or enter a number directly into the **edit box** between 0 and 100 to fold and unfold the current box template.

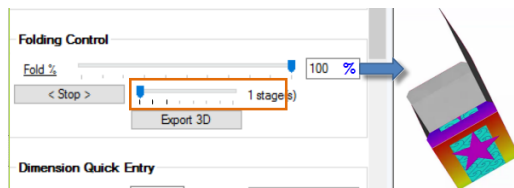

The **Play** button allows you to run an animation of the box or display. The stages slider is used to fine-tune the speed of the folding. Therefore, if you want to watch the box *Fold Stage by Stage*, then **tick the Stage you want Played**, example below shows **Stage 1 selected**, and hit the **> Play >** button.

You will see the box slowly fold the Main Panels (1) until **100%** folded and will automatically <Stop>. Image of box shown.

Now set tick to '2 stage' and **watch** what happens. Then **3** to fully close.

Now try this again but **tick stage to 3** and **ensure Fold % is 0**. You will see the box fold from start (flat) to finish (closed).

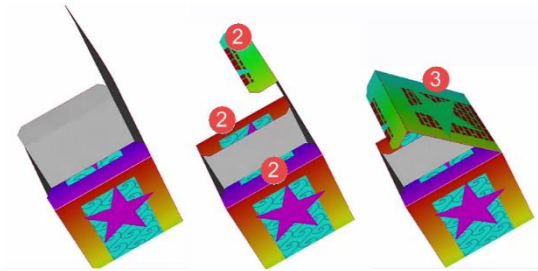

Step 7

Send to Flexi and Save File

The next tutorial will use this design, so save your file for future use.

Suggested file name: **02+ glueflaps.fs**

FreeForm Tutorial 104 - Simple Scale & Stretch Modes

In this tutorial, we will make the box that we made in Tutorial 103, double the size without altering the shape. Note that if your box is illustrated then this would be better achieved in your CAD program, as the illustrations will be scaled as well as the box. See also [Chapter 4 discussion](#).

Tutorial Video  [Simple Scale Propagation](#)

Open **02+ glueflaps.fs** that we saved in the Tutorial 103 of this manual (or open from [website](#))

Step 1

Scale Height with Width

If 'Scale Ht w Wth' is checked, the aspect ratio of the section remains constant if its width is changed. Otherwise the height remains constant if the width is changed.

The first thing we need to do, to ensure that *all 13 sections* remain proportional to the increase in size.

To do this...

- Select each, and *every*, *section* in the box individually.
- Tick the 'Scale' checkbox as shown.

Ensure that you include the 8mm Glue Flaps.

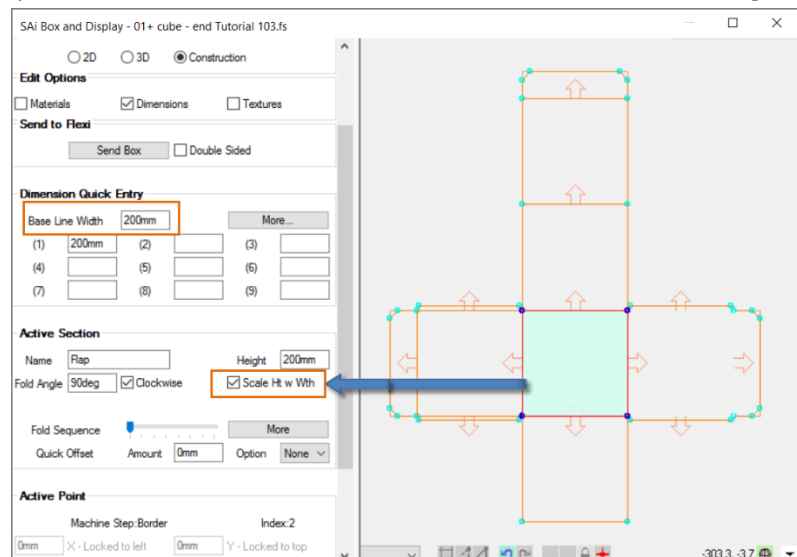

Step 2

Change stretch properties of points

When the box is increased in size, the glue folds will become much straighter and the chamfers much smaller.

To fix this problem we need to change the stretch properties of the points.

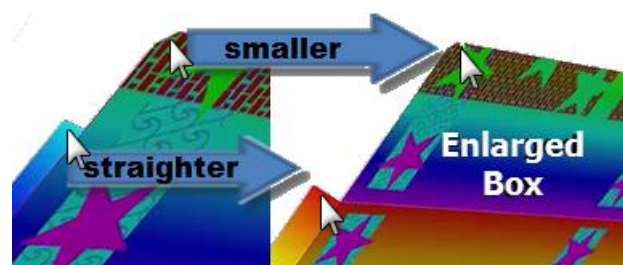

- Select the Active Section by using click and drag, as shown below left.

The result will be the presentation of arrows, which show the locking status pertaining to each point.

In the image, we see that the *little dark blue arrows*, closest to the pointer , are *locked* to the top and left edge of the section.

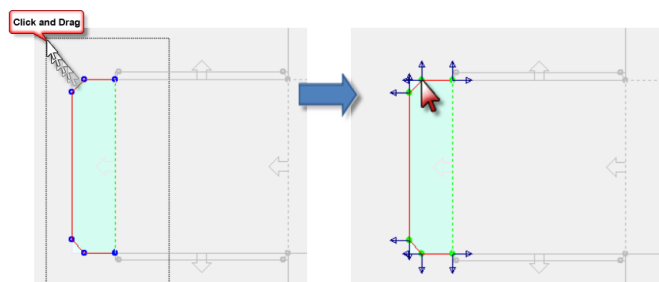

- Select the point as shown and, from the context menu, select **Horizontal Stretch Mode > Proportional**. Notice the change in all horizontal lines for the Active Section.

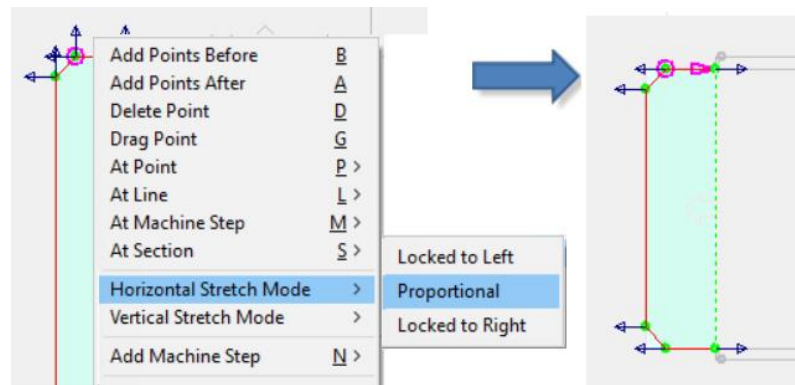

- Select the same point as shown and, from the context menu, select **Vertical Stretch Mode > Proportional**.

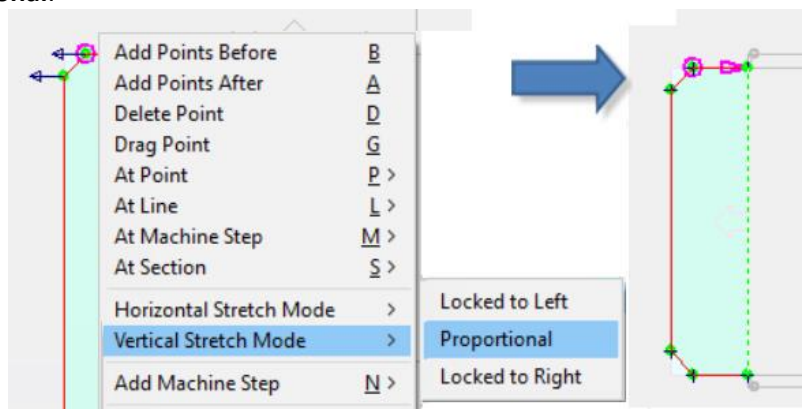

- Repeat this on all 3 flaps and 4 glue tabs...

Step 3

Enlarge Box

You can now enlarge the box by changing the Base Line Width, which in this tutorial is 1400mm.

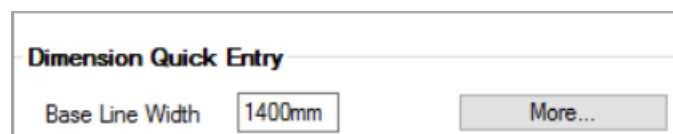

You will notice that every section has been enlarged proportionally. However, the illustrations will require amendments to suit.

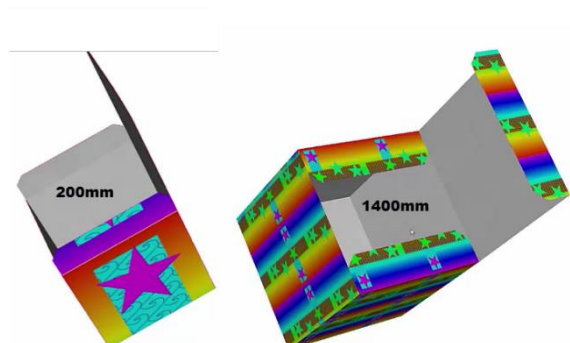

FreeForm Tutorial 105 – Parametric Scaling

The Dimension Quick Entry > **More** button, opens a dialog box that lets you extend the use of the 1-9 input controls. As you can see below, there is an edit box that allows you to **Name** the parameters for scaling and allows you to provide a **Formula**. The use of Formulas allows you to set a Section to a value and *if the value is changed* at a later time, then the *Sections will change* to the new value. This means that you can roughly create your box and later adjust the heights to achieve the desired aesthetic shape, as now discussed.

Tutorial Video  [Parametric Box Part 1](#)

In this tutorial video we are going to take a box we created in [Tutorial 112](#) using a static method and turn it into a parametric design to enable the control of some of the aspects of the rivet box e.g. sizes etc. using controls and formulas to provide you with the ability to repurpose the box for other uses.

First we have to assign dimensions to the different parts, enabling them to be controlled by a formula.

Step 1

View in SAi Box Display

- Open **04- RivetBox1.fs** from [website](#)
- Use the “eye”  button to **View in SAi Box Display**

Step 2

Dimension More button

- Select **Construction View** and tick the **Dimensions** checkbox.
- Press the **More...** button as shown above to open the dialog box.

Currently, the parameters in the **Advanced Edit Properties dialog** correspond to the **Quick Slots (1-9)**. If you *change the dimension values* e.g. (1) 200 to 300mm, there will be *no change to the sections on the box* assigned the value set in Quick Slot (1). We need to create a formula.

- **Copy the Values in the Edit Properties to the Formula area** →

Ensure Formula values state unit of measure i.e.
- if **millimeters** state **mm**,
- if **inches** state **in** etc.

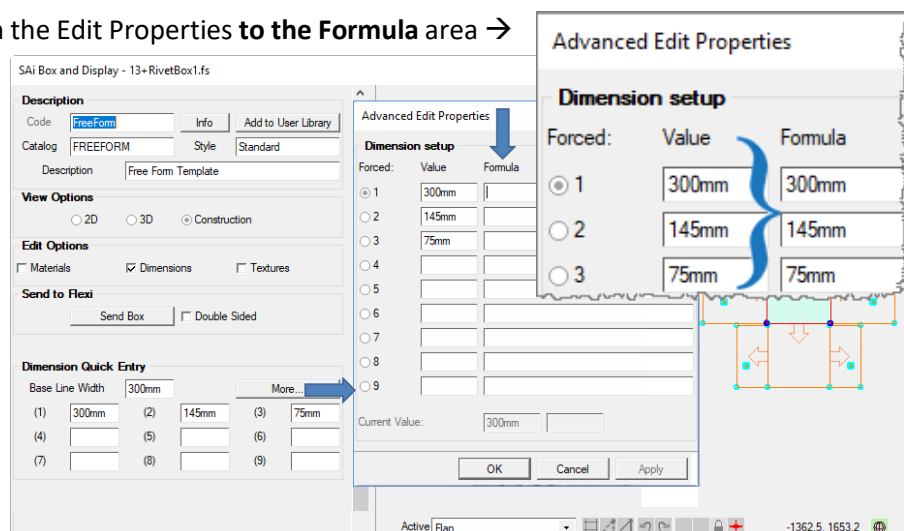

Now we **need to connect** the Formulas to the applicable areas in the box.

Step 3

Connect Values to Formulas

- Enter descriptive names in the **Value** fields, as shown below, i.e.
 - BoxHt** = 300mm
 - FlapHt** = 145mm
 - LidHt** = 75mm
 - Add **BoxDep** = 300mm

Note that after you **click OK** to close the Dialog, the Dimension Quick Entry slots are changed to the descriptive value names.

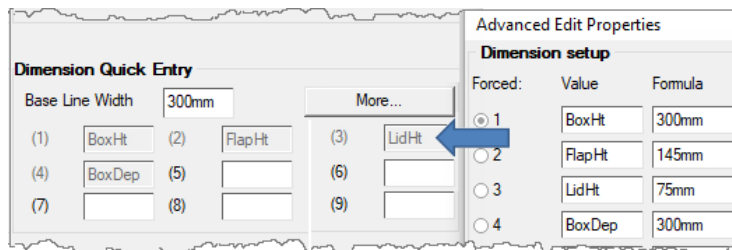

The diagram right, is numbered to represent the different panels and flap i.e. 2 are Flaps etc.

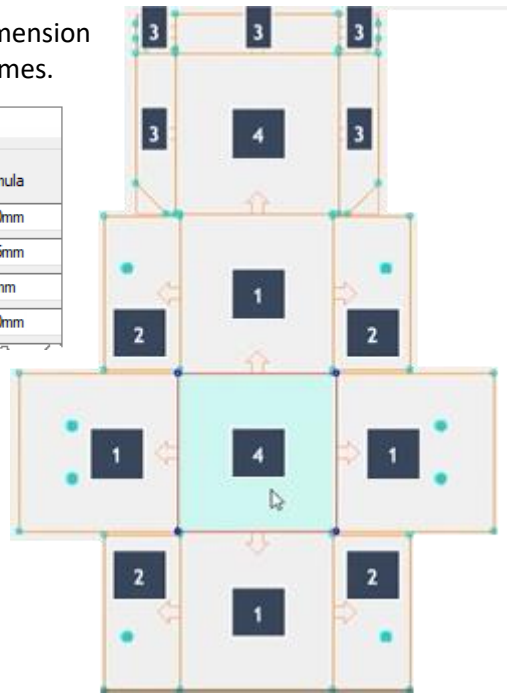

Step 4

Apply Formula to Sections Forced Parameter (1)

- Select (double click to make Active) each of the four sections shown with **1** one at a time and ...
 - Right click to get context menu
 - Select **At Section** and **Adjust Section Height**
- Drag out using mouse past width, as shown, and press **1** to apply Formula dimension and **left click** mouse.

As we are applying the same height of 300mm to each section it seems that there is no change. **To test** that your changes have worked, simply **change the Formula value** in the 'Advanced Edit Properties' from 300mm **to say 400mm**. All related sections should change to the new 400mm size.

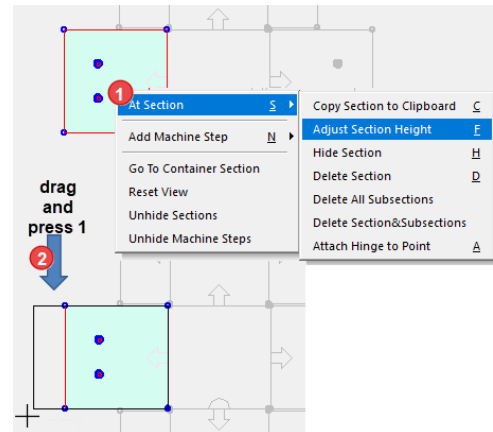

Step 5

Apply Formula to All Sections

- Repeat Step 3 for all other numbered sections in the diagram. Ensure you **test** that these are working as expected.

Note that even though the sections are changing in size the chamfers, rivet holes etc. are **not**.

The next tutorial and video will explain how to correct this.

Tutorial Video  [Parametric Box Part 2](#)

After checking that parametric scaling is correctly working for *each section*, we will now deal with other elements of the box so that they will change in proportion to the new dimensions.

In the previous tutorial, we discussed [Simple Scale & Stretch Mode](#). The following uses what we learned.

Step 6

Proportional Stretch Mode to Chamfer

Make the section **Active**, then...

- Select points of the lid flap **3** indicated in the diagram by using left click and drag to right.
- The result will be the presentation of *dark blue arrows* called stretch modes and they tell you where the point is anchored and the locking status pertaining to each point. The blue arrows closest to the pointer  are *locked* to the top and left edge of the section.
- Select the two points as shown and, from the context menu, select **Horizontal Stretch Mode > Proportional**. You will need to zoom in on this area to select correctly.

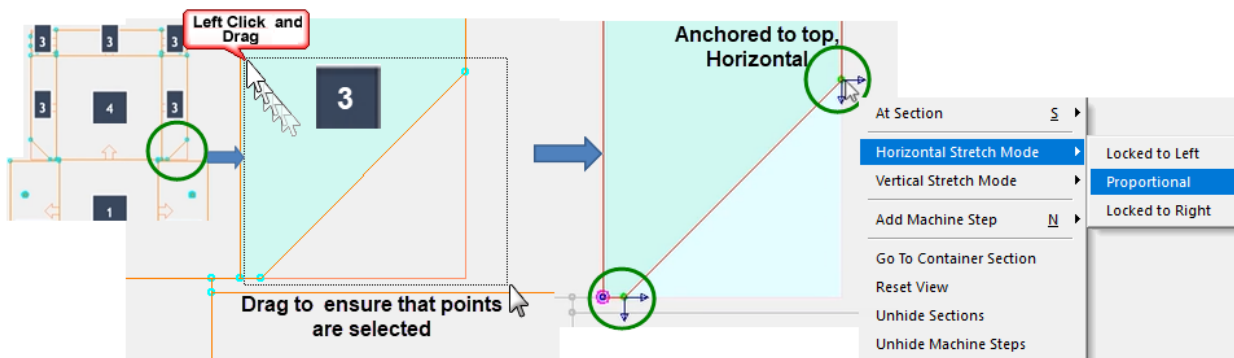

- Notice the change in all horizontal lines for the Active Section →
- Select the same point as shown and, from the context menu, select **Vertical Stretch Mode > Proportional**.
- Repeat on opposite lid flap.

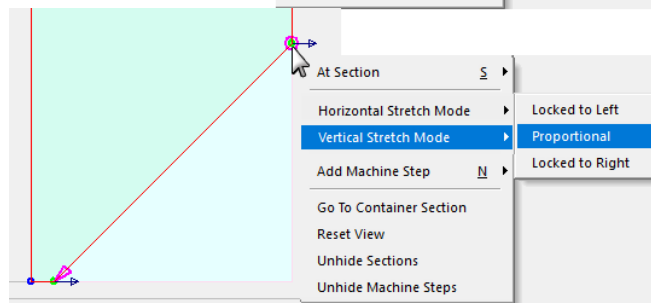

Step 7

Proportional Stretch Mode to Tab

- Select points of the lid tab **3** indicated in the diagram and repeat step 5 for horizontal and vertical stretch modes.
- Repeat on opposite lid tab.

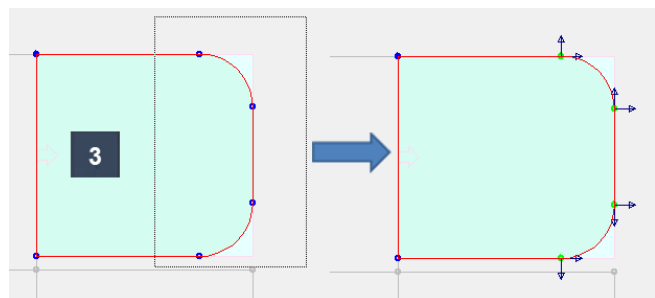

Step 8

Proportional Stretch Mode to Rivet

- Repeat on all rivet holes. You can select multiple rivet holes, in each active section, at the same time.

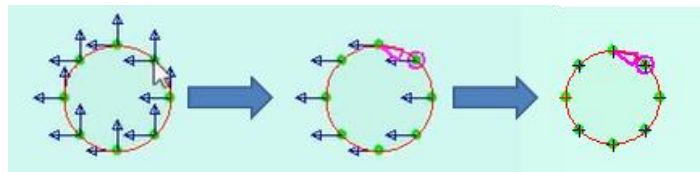

You can zoom in on rivet holes, as shown but it is not necessary.

After completing the previous steps, test that when you change the dimensions of *individual* flaps, the rivet holes move proportionally to the change.

Tutorial Video [Parametric Box Part 3](#)

In this tutorial, we are going to show you how to set it so that everything changes proportionally to *width of your base line*.

To do this we need to replace the current settings with a formula that relates to the base line.

Step 9

Proportional to Base Line

Replace current settings with formula i.e. $\text{BaseLineWth} * \text{current setting} / \text{base line width}$

- Enter descriptive names in the **Value** fields, as shown below, i.e.
 - BoxHt** = $\text{BaseLineWth} * 300\text{mm} / 300\text{mm}$
 - FlapHt** = $\text{BaseLineWth} * 145\text{mm} / 300\text{mm}$
 - LidHt** = $\text{BaseLineWth} * 75\text{mm} / 300\text{mm}$
 - BoxDep** = $\text{BaseLineWth} * 300\text{mm} / 300\text{mm}$

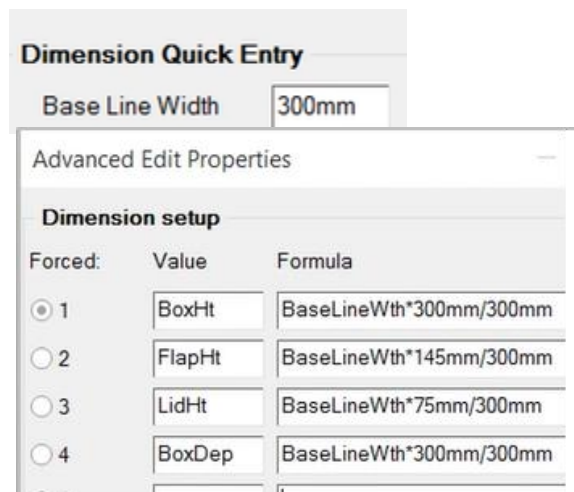

Test that this works i.e. change the Dimension Quick Entry 'Base Line Width' to 500mm. If an area doesn't change then you may need to repeat [Step 4](#) to applicable area.

Step 10

Add to User Library

Now we will save these changes so that you can use this as a template for future use.

Here we changed the Code Freeform to 'RivetBox_PM' and then clicked '[Add to User Library](#)'

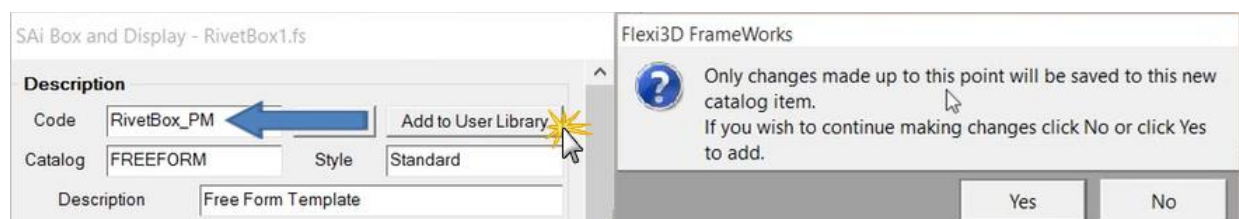

FreeForm Tutorial 106 – Making Custom Flaps

In this tutorial, we are going to make a Flap from scratch which approximates* the shape of the Dust Flap that can be imported from the Library (discussed further in Tutorial 109). We will also learn about Machine Steps and how to Open/Close and Hide/UnHide. [Note: * exact measurements are not required in this tutorial].

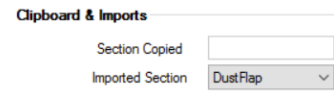

Tutorial Video [Making Custom Flaps](#)

Step 1

View in SAi Box Display

- Open **05-customflaps.fs**
- Use the “eye” button to **View in SAi Box Display**

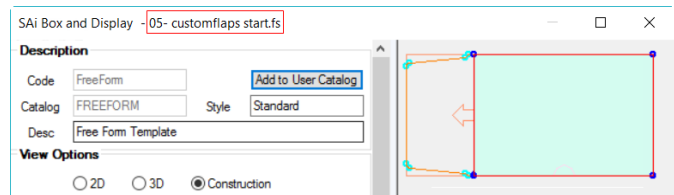

Step 2

Add Basic Flap

Note: Flap and Panel are synonymous terms in the construction view

- **Right click** on the Main Section (above highlighted Active) to bring up the context menu.
- Press **L > F** to add a basic flap, measurement doesn't really matter at this stage (Height of custom flap on left is 113.3mm. To get exact measurement use Quick Entry box. Image is 150mm)

Notes on Machine Steps

You will notice that there are two [machine step](#) components to this flap...

1. the red border
2. the dotted green fold line

If you click on the **top right point**, as shown , the status bar shows that this is point 2 of the border i.e. **Pt2_Border**.

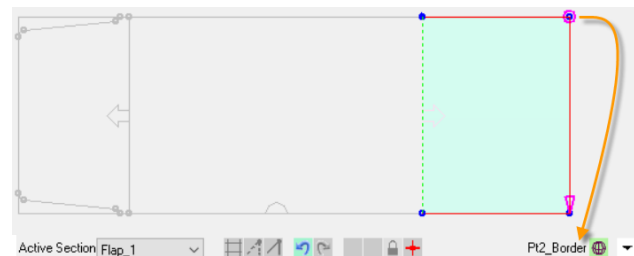

The **arrow** points to the next point in that machine step.

If we click on *each of the points* on the Active Section, note that the description of the **2nd** and **3rd** images **are at the same point** but the 1st click on this point is the **+Pt2_FoldLine** and the 2nd click is **+Pt4_Border**.

Note that the description of the last 3 points have a + in front of description i.e. **+Pt2**, **+Pt4**, **+Pt1** which indicates that there is *more than one point which can be potentially selected*.

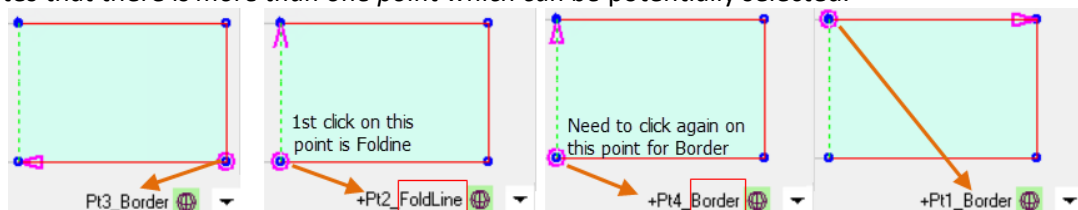

These are **Open Machine Steps**.

Notes on Open/Close Machine Step

Since P2_FoldLine and Pt4_Border are both available for selection, we want only one candidate for selection, which is Pt4_Border. We, therefore, need to close the Machine Step. To do this click on the point as shown...

1. click and ensure **Pt2_FoldLine** and then right click for menu select **At Machine Step > Open/Close Machine Step**
2. click and ensure **Pt4_Border** and then right click for menu select **At Machine Step > Open/Close Machine Step**

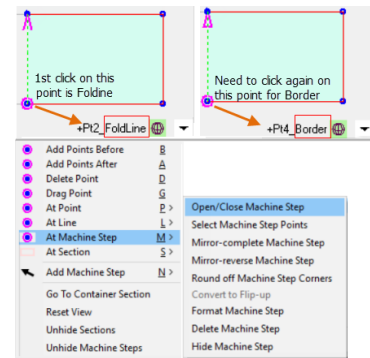

To see the result of this we need to hide the FoldLine.

Notes on Hide/Unhide Machine Step

To hide the FoldLine...

- click on the point and ensure **P2_FoldLine**
- right click for menu
- select **At Machine Step > Hide Machine Step**

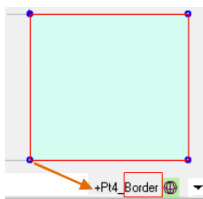
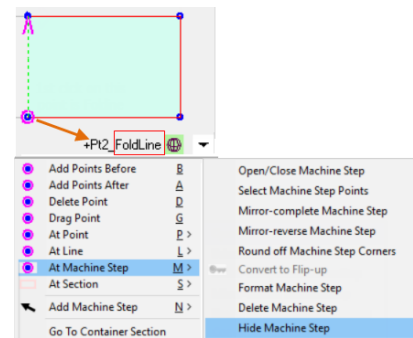

Now when you click on this point, you will notice that there is *only one point* remaining for selection i.e. **Pt4_Border**.

If you want to see the green dotted FoldLine again, just select **Unhide Machine Steps** from the context menu as shown →

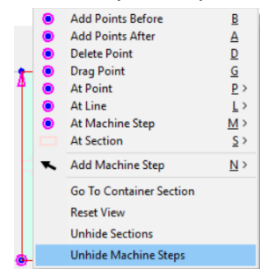

Notes on Coordinates

The points are **Cartesian** i.e. consisting of a set of two lines intersecting each other at right angles, but are rotated so that the Base Line is the X-axis and the intersecting line is the Y-axis, and the point of their intersection is called the origin with the coordinates (0, 0).

Note that the **Global** [0.0, 0.0] origin will always be determined by the **Original Base Line**.

However, as in the case of the image below, the Active Section's Fold Line becomes the Base Line. This determines the **X** coordinate.

On the diagram, right, when a section is Active, **Pt1** in **Local mode** is the **origin** and its Local coordinates become [0.0, 0.0]. The coordinates of Pt2 are X = 0mm and Y = 150mm (Active Point Index:2 relates to Pt2)

Coordinate Selector

- Local Coordinate if greyed out.
- Global Coordinate if green.

Left click to toggle between modes.

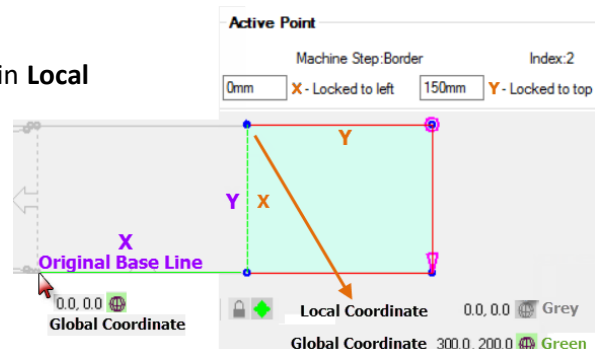

Step 3

Drag Point Points 2 and 3

We now want to make a dust flap similar to the custom shape.

- Select **Pt_2** and, from the context menu, select **G** for Drag Point and hold 'shift' key while dragging to constrain to same vertical line as before.
- Release mouse and **Left click** to set point.

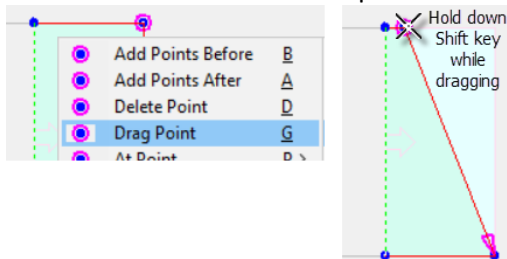

- Select **Pt_3** and, as per image, drag point. The point will look as if it is in mid air.

To find out where this point is sitting, look at the **x,y** coordinates in **local mode**. Remember the Green FoldLine is now the Base Line and therefore the X Coordinate.

You can also look at the **Active Point** on property inspector, as shown.

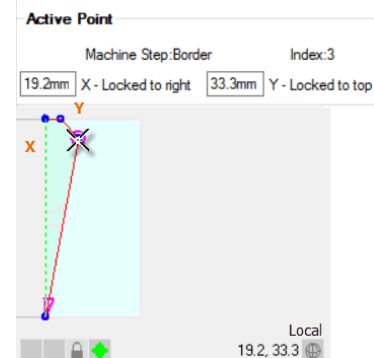

Step 4

Add Point After

As per the image below, do the following...

1. Select **Pt_4** and drag point to approximate position as shown in *fig.1*. (Ensure that the point that you select is Pt4_Border before dragging)
2. Since there is no more points to drag, we now need to select 'Add Points After' from context menu. Drag to create **Pt_5** to approximate position as shown in *fig.2*.

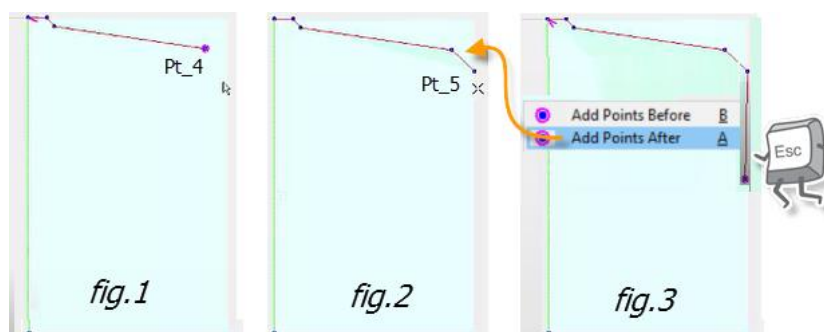

There are a number of ways to set the point to an **exact position**, for example...

- Drag the point and go into numeric entry mode by using the 'period' key. (see [Tutorial 103 - Step 2](#))
 - Go into Snap to Grid mode and drag it until snap (see [Tutorial 103 - Notes on Alignment and Snap to Grid](#))
3. We can continue to 'Add Points' as shown in *fig.3* but to replicate what we have created so far will involve a lot of measuring, so we will 'esc' here and 'Mirror' these Machine Steps.

Step 5

Mirror Complete Machine Step

- From the context menu, select 'At Machine Step' > 'Mirror-complete Machine Step' as shown.
- The result will be a completed dust flap, shown below right.

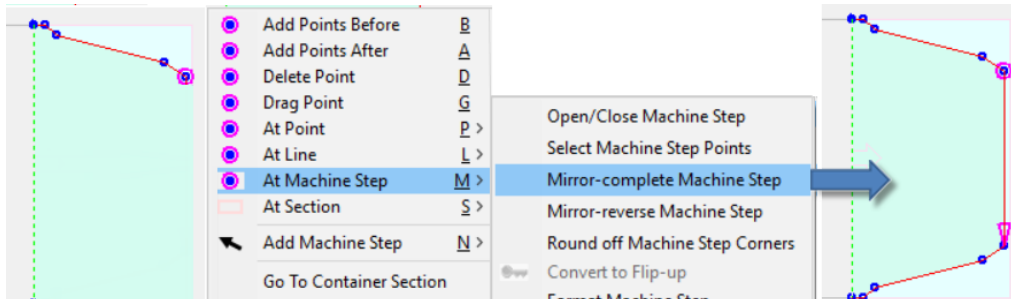

Step 6

Curve Line

The final step is to [curve](#) the two lines.

- Select the line shown.
- Select 'At Line' > 'Curve Line' from the context menu.
- Drag the line and hit the 'period' key
- You will get a dialog, from which we will use the 'Tangent to Prev' button [the curve will become 0.086 as per the dust flap on left]

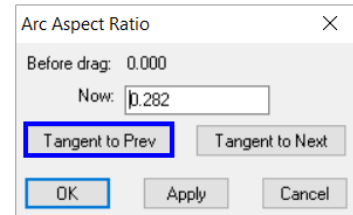
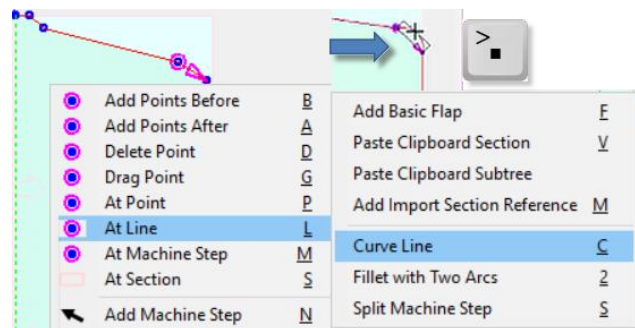

Repeat the above for the corresponding line but this time...

- Use the 'Tangent to Next' button

Result

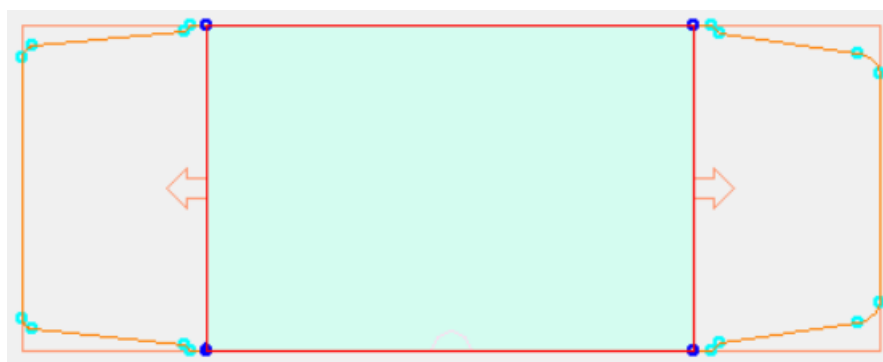

FreeForm Tutorial 107 – Repeating Commands

Tutorial Video  [Repeating Commands using ctrl-R](#)

Repeatable commands:

The following commands can be repeated using **ctrl-R**.

Note that you can only repeats the last command executed.

- Drag Point
- Add Basic Flap
- Paste Clipboard Section
- Paste Clipboard Subtree
- Add Import Section Reference
- Chamfer Corner
- Fillet Corner (rounded)
- Adjust Two Arc Corner
- Curve Line
- Fillet with Two Arcs

<input checked="" type="radio"/> Add Points Before	B	Add Basic Flap	F
<input checked="" type="radio"/> Add Points After	A	Paste Clipboard Section	V
<input checked="" type="radio"/> Delete Point	D	Paste Clipboard Subtree	
<input checked="" type="radio"/> Drag Point	G	Add Import Section Reference	M
<input checked="" type="radio"/> At Point	P >	Chamfer Corner	C
<input checked="" type="radio"/> At Line	L >	Fillet Corner (rounded)	R
<input checked="" type="radio"/> At Machine Step	M >	Adjust Two Arc Corner	I
<input type="checkbox"/> At Section	S >		
Add Machine Step	N >		

<input checked="" type="radio"/> Add Points Before	B	Add Basic Flap	F
<input checked="" type="radio"/> Add Points After	A	Paste Clipboard Section	V
<input checked="" type="radio"/> Delete Point	D	Paste Clipboard Subtree	
<input checked="" type="radio"/> Drag Point	G	Add Import Section Reference	M
<input checked="" type="radio"/> At Point	P >	Curve Line	C
<input checked="" type="radio"/> At Line	L >	Fillet with Two Arcs	Z
<input checked="" type="radio"/> At Machine Step	M >		
<input type="checkbox"/> At Section	S >		

In this tutorial, we will start with a 300mm x 300mm square and create the following using ctrl-R.

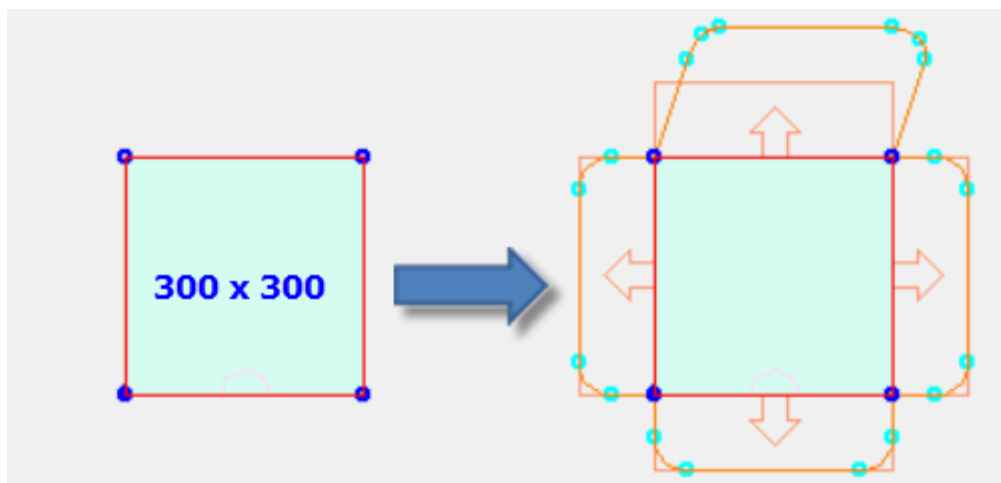

Step 1

Main Section – 300 x 300

For this tutorial, we will start with a 300 x 300 Main Section (as shown above)

- Open file **06- repeating.fs** (or open from [website](#))
or
- create by right clicking on the 'Base Line' and choose **At Line > Add Basic Flap [L > F]** from the context menu.

Step 2

Add Basic Flap

Now add a flap [L > F] on one side of the Main Section (the dimensions are not important), then use the **ctrl-R** command to each of the 3 other sides to replicate, as shown.

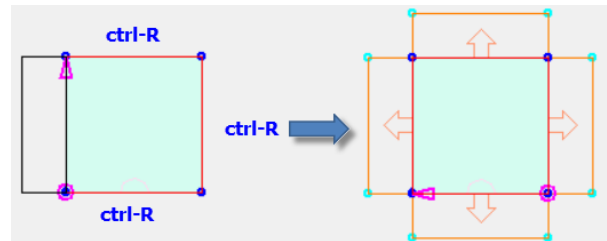

Step 3

Fillet Corner (rounded)

Now we will **fillet** one of the corners and repeat this to all the other corners using **ctrl-R**. Remember to make each of the sections Active before selecting the Point to be Filleted.

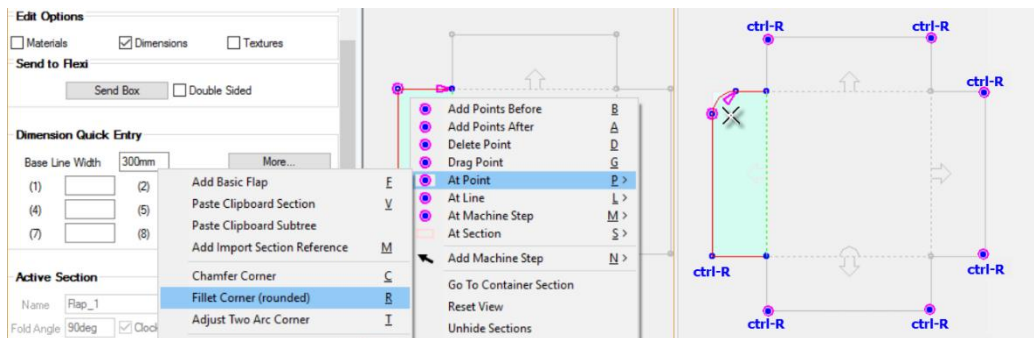

The result will look like this. Now we will resize the top flap.

Step 4

Resize Flap

- Select the left-hand point as shown in *fig.1*
- From the context menu, select **G** for Drag Point and hold '**shift**' key while dragging to constrain to same vertical line as before.
- Release mouse and Left click to set point.
- Now select each of the other 3 points and use **ctrl-R** to repeat as shown *fig.1* to *fig.4*

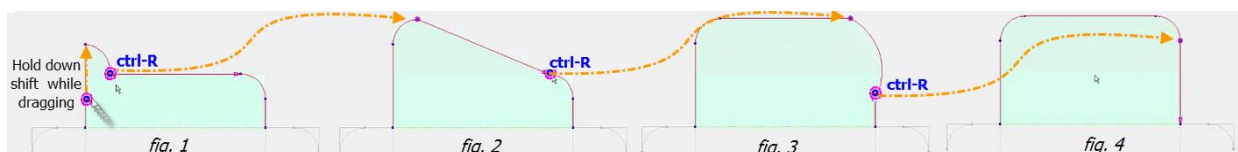

Step 5

Non-Orthogonal Direction

If we repeat this in a non-orthogonal direction, we can still use ctrl-R and it will move the point by the same vector as the previous one.

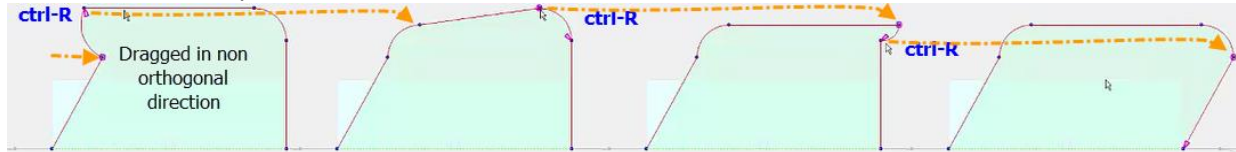

Step 6

Fillet with Two Arcs

Since the corners are a little messy, we will use the **L** > **Fillet with Two Arcs** command and repeat this on the other side, using **ctrl-R**, to get the result as shown below right.

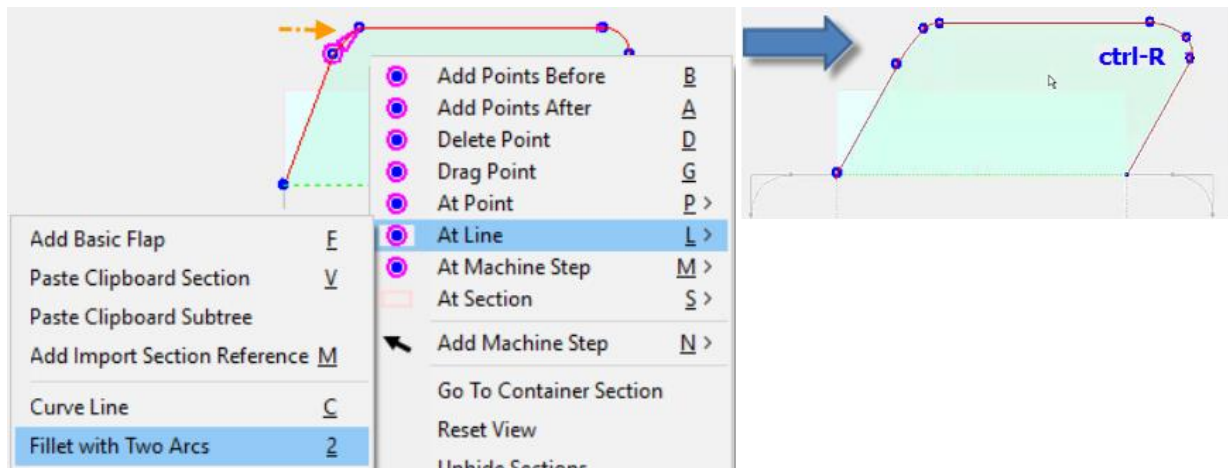

FreeForm Tutorial 108 – Curves and Fillets

This tutorial is not only about curves and fillets but also how to create cutouts, square and circular.

Tutorial Video  [Curves and Fillets](#)

Step 1

View in SAi Box Display

- Open **07- curves.fs** (or open from [website](#))
- Use the “eye”  button to **View in SAi Box Display** You will be starting with a box with cutout as shown.

If you cannot open the required file, don't worry.

Just make two rectangles, similar to the above, as we will learn to add a cutout in Step 9 of this tutorial.

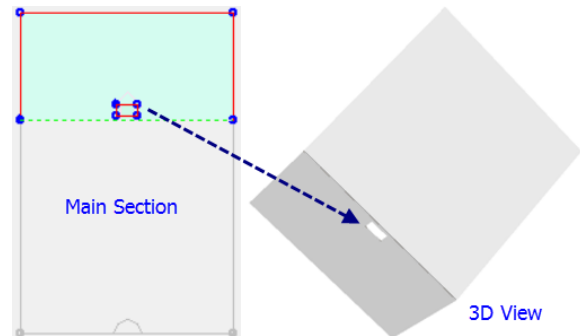

Step 2

Snap to Grid

See also [Tutorial 103 – Notes](#)

- Turn on Snap to Grid  by left clicking on icon.

Note: Right clicking on  icon will open the **Grid Spacing** dialog.

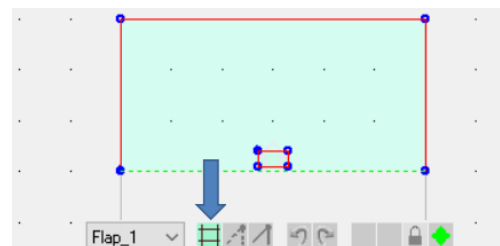

Step 3

Add Base Line for tab – Add Points After

1. Left click on Pt2 and from context menu select **Add Points After A** (*fig.1*)
2. Drag to right (*fig.2*) and left click to apply. [Tip: Hold down shift while dragging]
3. Left click again and drag to right (*fig.3*) and left click to apply. Then hit 'esc' to complete.

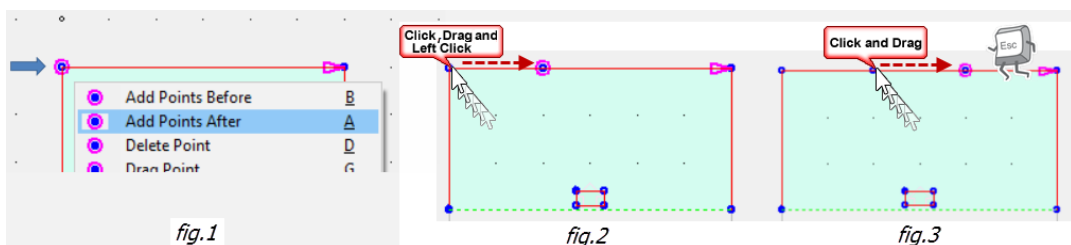

Step 4

Curve Line

Now we have created a Base Line for the Curve.

- Right click Base Line and from context menu press **L > C** Curve Line
- Drag up to create curve – see step 5

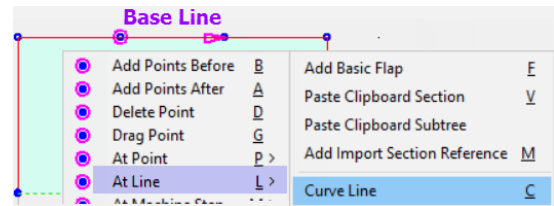

Step 5

Curve tab and Change Radius

If we drag sufficiently far enough from the base line then we get a semi-circle either on the inside (fig.1) or on the outside (fig.2). For this tutorial, we want a semi-circle on the outside (fig.3).

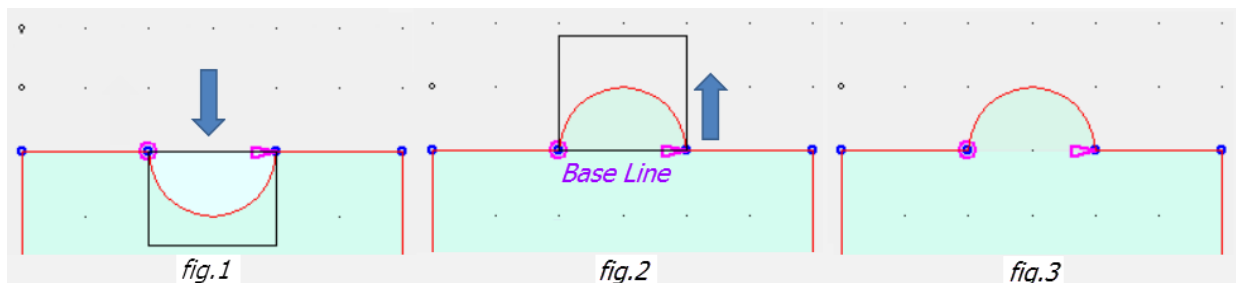

To change the radius of the curve line, repeat Step 3. Note that the radius cannot be greater than the length of the Base Line, however, there are ways to get around that, which we will discuss later in Step 10 of this tutorial.

Step 6

Add Fillet Corner (rounded)

- Right click LHS point as shown (fig.1) and from context menu press **L > R** Fillet Corner
- Drag up to create fillet (fig.2) and press 'period key' to bring up Corner Dimension dialog. Enter in
- Repeat command on RHS point using **ctrl-R**.

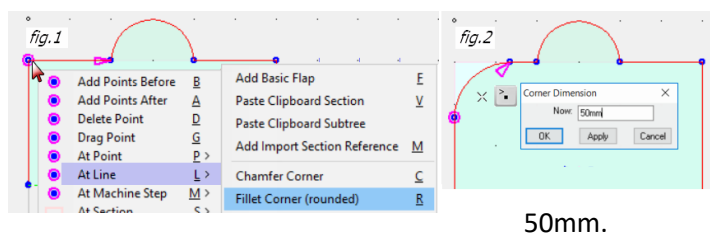

The resulting curve is nicely **tangential to the straight edges**.

If we look at this, below, in 3D View we can see the result. The curve is shown both inside and outside.

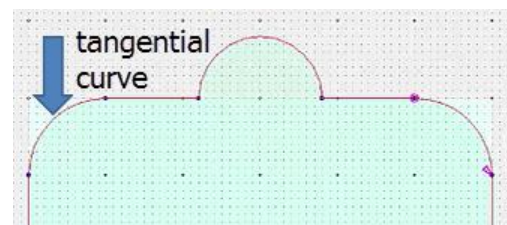
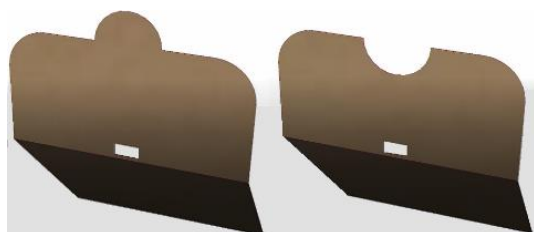

Tangent
The tangent line to a plane curve at a given point is the straight line that "just touches" the curve at that point.

Step 7

Tangent to Prev / Next

In this step, we are going to produce a **tangential curve** automatically in two different ways.

1) Change our initial curve (*fig.1*) to an inside curve that looks like *fig.2*, so we can illustrate affect.

- select and right click the Curve Line to get context menu
- select At Line **L** > **C**urve Line and use the 'period key' to get **Arc Aspect Ratio** dialog
- press the '**Tangent to Prev**' button (*fig.3*). The curve will revert to *fig.1*.

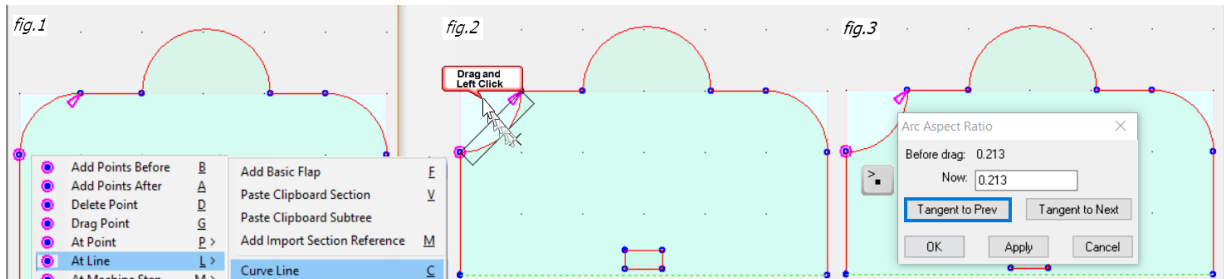

2) Again, change our initial curve so that it is no longer tangent to the straight part. Do this by using **G** Drag Point (*fig.1*) to move top LHS point so that it roughly corresponds to image *fig.2*.

- select and right click the Curve Line to get context menu
- select At Line **L** > **C**urve Line and use the 'period key' to get **Arc Aspect Ratio** dialog
- press the '**Tangent to Next**' button and you will see that the curve is now tangent to the line (*fig.3*).

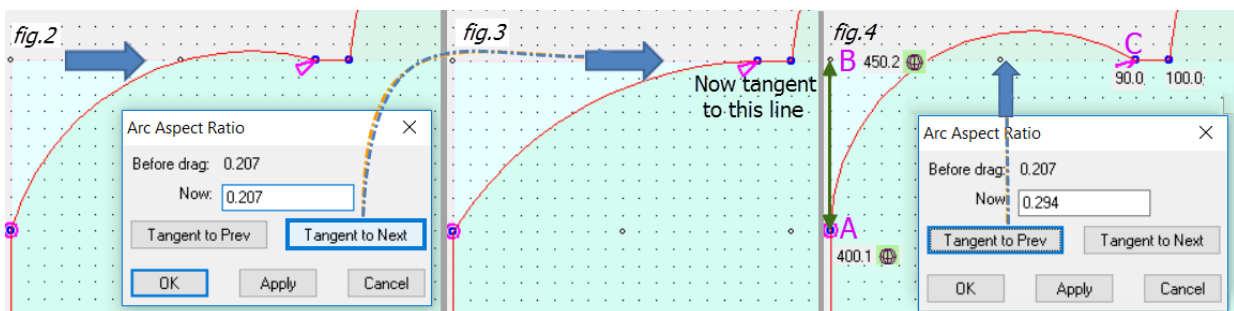
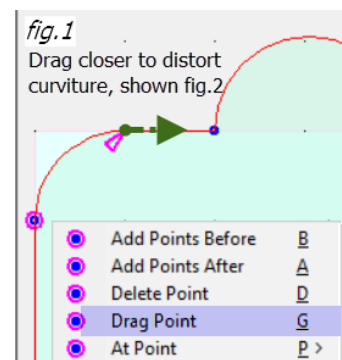

Note: If you press '**Tangent to Prev**' as in *fig.4*, you will see that you get a different result. This is because it is impossible to get the curve tangent to both straight lines because the distance from **A** to **B** in *fig.4* is 50 and the distance for **C** is 90. The next step will discuss how we can overcome this issue.

Notes on Section Boundaries.

You will note that as you create curves, fillets and cutouts, a light blue area will still be visible to define the section boundary but is not useful for selecting the section. It is just a convenience for construction view and is not used for machining purposes.

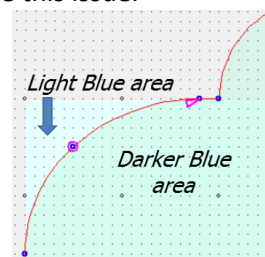

Step 8

Fillet with Two Arcs

There is a special method to fix the issue described in *fig.4* above. It is a two curve fit.

- Right click the Curve Line
- from the context menu select At Line **L** > **2** Fillet with Two Arcs (*fig.1*).

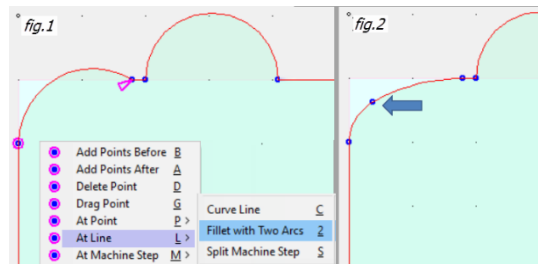

This produces a special double curved line (*fig.2*) which will be tangent at both ends and it also has a continuous tangent at the join of those two points

Step 9

Adjust Two Arc Corner

Here, we have changed our double arc curve by using **G Drag Point**, so that the curve is no longer any good (*fig.3* arrow ). Fix by..

- right click the point of the curve line shown in *fig.3* , and
- from the context menu **P** > **I** Adjust Two Arc Corner. The result is shown in *fig.4*.

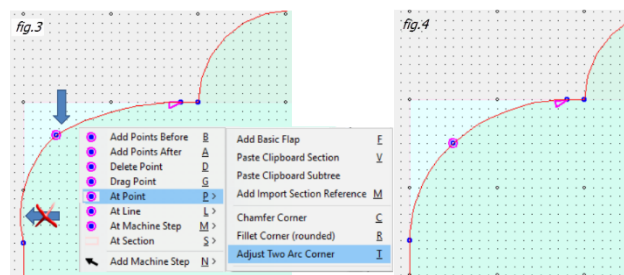

Step 10

Add Machine Step / Hole

See also [At Line / Add Slot](#) (Rectangular or Circular)

a) Square Hole – to add this ...

- Right click and from the context menu, select **Add Machine Step N** > **H** Hole.
- Left click at required intervals, as shown below points 1-5, to form a square. Note: To constrain the line to last point and keep straight hold down the 'shift' key while creating the square.

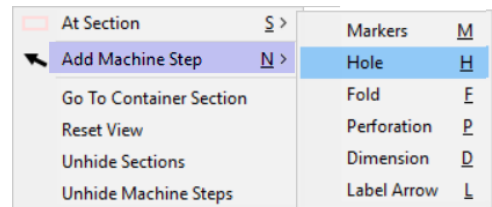

The 3D View shows the result.

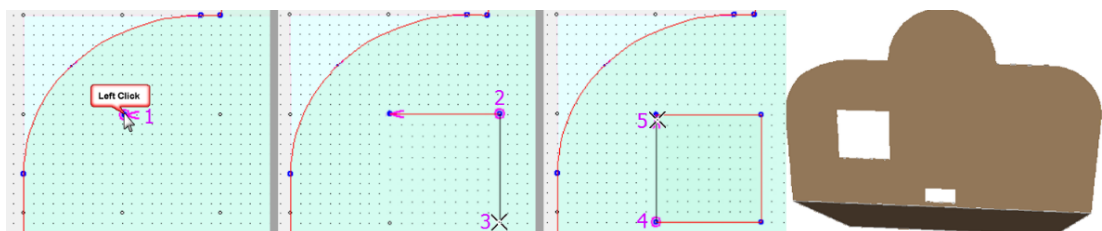

b) Round Hole –change square into a circle.

- Right click and from the context menu, select **At Machine Step M > Round off Machine Step Corners**.

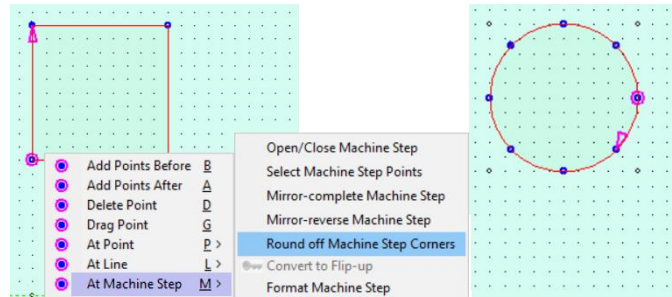

See also [At Line / Add Circle or Oval Slot](#)

c) Elliptical Hole –change square into an elliptical cutout.

- Change the square into a rectangle, as easier to convert. Otherwise would have to drag 8 points.
 - Select point **1** shown and from context menu select **Drag Point G** and drag.
 - Select point **2** shown and use **ctrl-R** to repeat drag point.

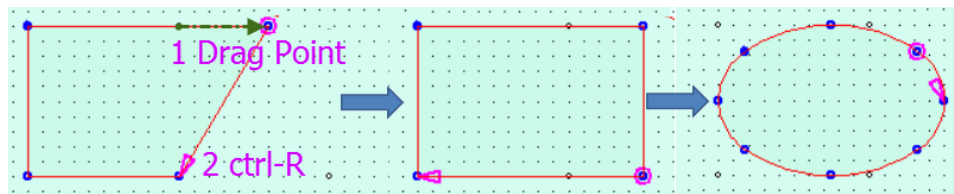

- Right click and from the context menu, select **At Machine Step M > Round off Machine Step Corners** (as per Step 9b above)

Step 11

Radius Greater than Base Line

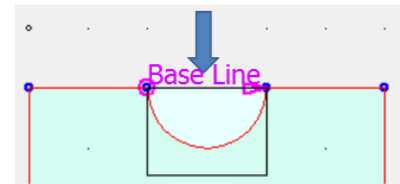

In step 4 we mentioned that the radius of a curve cannot be greater than the length of the Base Line, however, there are ways to get around that.

First, create a Rectangle

- Right click and from the context menu, select **Add Machine Step N > Hole**.
- Left click at required intervals, as per Step 10a and shown *fig.1*, to form a rectangle which protrudes outside the Active Section.

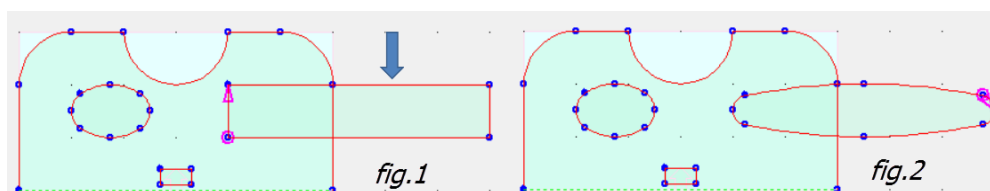

Then, create an Elliptical hole

- Right click and from the context menu, select **At Machine Step M > Round off Machine Step Corners** to create an elliptical hole as per *fig.2*

The 3D View shows the result.

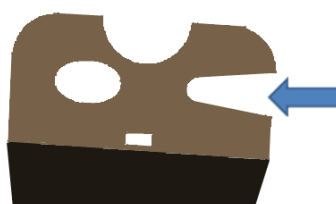

FreeForm Tutorial 109 – Import Predesigned Flaps

In this tutorial, we are going to learn how to import a library flap into your custom drawing and edit the import to suit your requirements.

Tutorial Video  [Importing pre-designed flaps](#)

Step 1

Create Basic Flaps

- Create the two rectangle Flaps – see picture in Step 3 below.
Exact measurements are not required.

Step 2

Clipboard & Imports

- Select the **Dimensions** Edit Option
- In the **Clipboard & Imports** section, shown right, there is a dropdown menu with a list of [available flaps](#).
- Select '**ExtBackTuck**' for this tutorial.

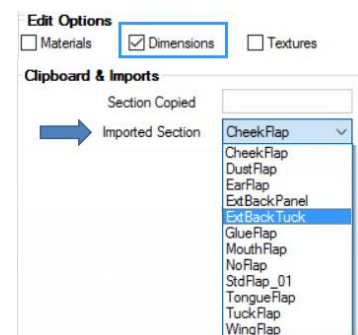

Step 3

Add Import Section Reference

- **Right click** the Line on the Active Main Section, as shown, to bring up the context menu.
- Press the **L** key for At Line fly out menu
- Press the **M** key for Add Import Section Reference, **drag** to size and **left click**.

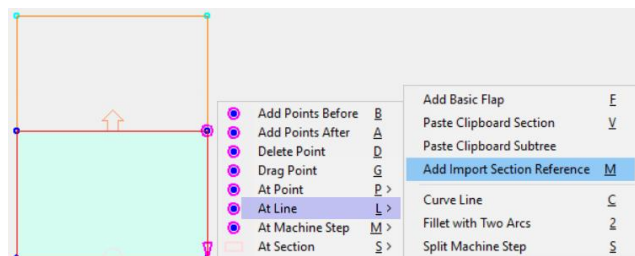

As you can see here the 'ExtBackTuck' is added, which has in itself, three (3) sections. Click on each of these sections to make Active [Top RHS of image shows middle section **2** as Active].

Edit Import: Each of these imported flaps comes with a dialog box which allows you to move various parts of the flaps, as appropriate.

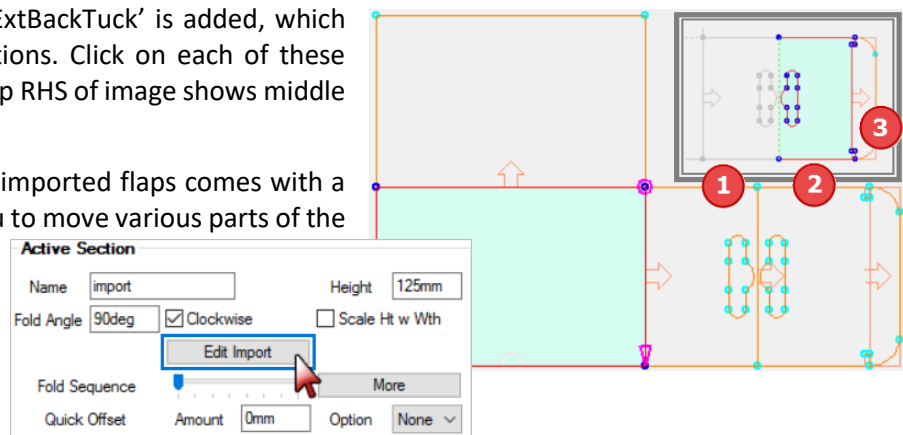

Step 4

Edit Import

- Click on 'Edit Import' button, shown above.
- The image right shows the unedited dialog
- Change the Slot Height **2** from 18.3mm to 12mm
- Note the change to Active section is mirrored in corresponding section.

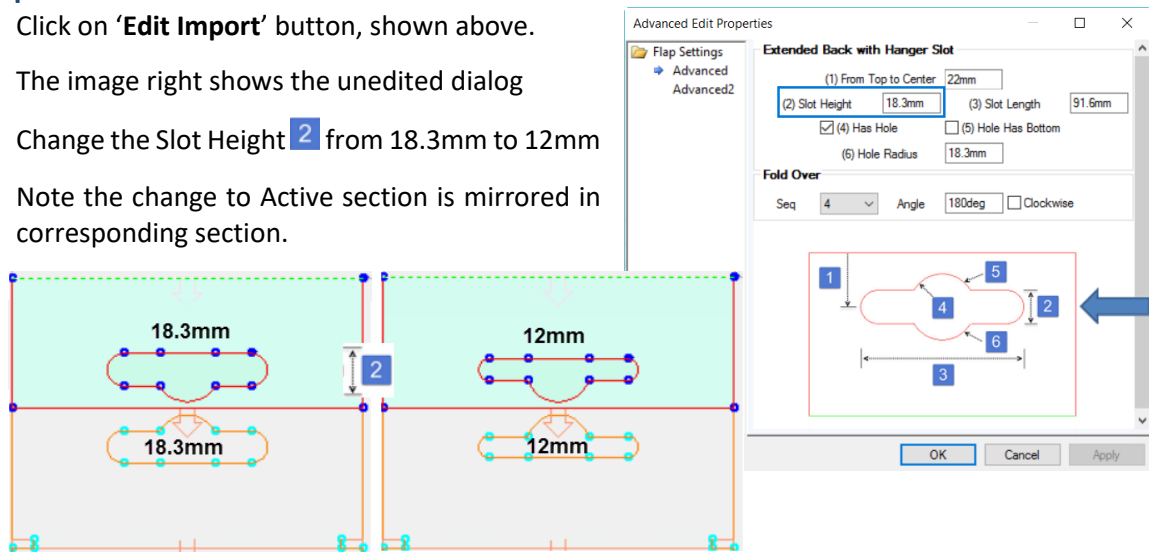

Important Note: You may wish, at a future time, to convert the section into construction view (discussed in Step 6). When you convert to construction view, you will no longer be able to Edit using the dialog box. *It is therefore important that you ensure that all the changes you require have been made before converting to construction view.*

Step 5

Resize Parent Section

- Right click the Active Section for context menu
- Press At Section **S** > **F** Adjust Section Height

Notice that the imported Flaps will adjust in height to correspond, in a way *envisaged by the designer* of the flap, not in the standard construction view way.

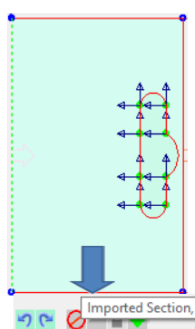
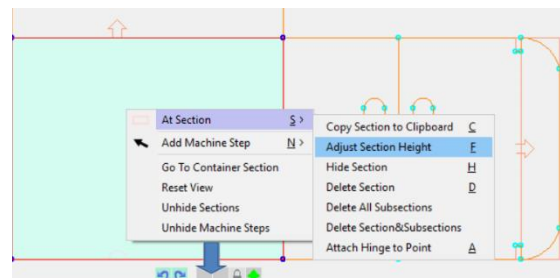

So, anything you have here in stretch* properties are arbitrary and ignored at this point. Note in the *image above*, it shows the Main Section Active and the Indicators grey at the bottom of the Preview Pane.

When the imported flap section is Active and you hover \leftarrow over the 'No Entry' \propto sign it tells you that it is **imported and cannot be edited in construction view**. You will also find that options on the context menu will be greyed out (or unavailable for selection) – as per image on the right \rightarrow .

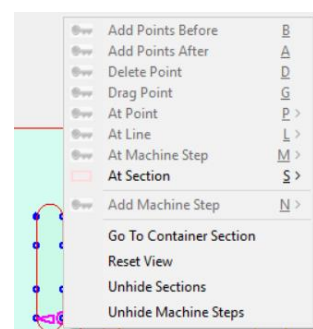

* For notes on stretch properties see [Tutorial 104](#)

- We can also create a copy of the 'ExtBackTuck', with changes that we have made, to the other side.

Copy using either **ctrl-C** or **S > C** then Paste [**ctrl-v**] to other side of Main Section as shown.

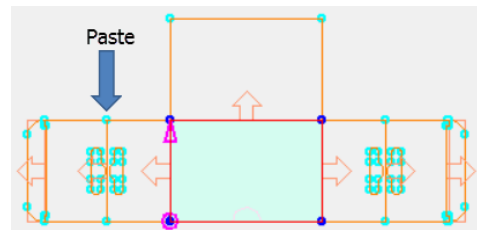

Step 6

Convert to Standard Construction View

This is a 2 step [process](#). Remember to make all the changes you require before continuing.

- Click on the 'No Entry'  sign and you will get this message.

Click OK to 'Convert to local copy' message.

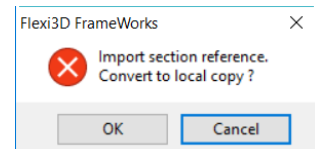

- Note that the 'No Entry'  sign is still showing as the machine steps are still not in standard construction view form.

Click on the 'No Entry' sign again and click OK to 'Eliminate formulas' message.

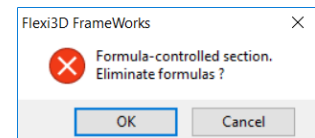

If you now click on the 'Edit Box' you will get a message that the Flap cannot be unlocked, however, you can still Undo the 2 steps discussed above. Remember to Undo twice, once for each step.

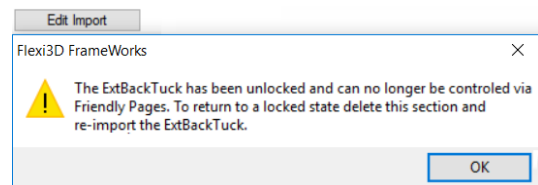

Step 7

Make Changes to Slot

We can now make changes to the individual slot.

- Select Pt_1 of the Slot as shown below left in *fig.1* and Drag Point as shown in *fig.2*.

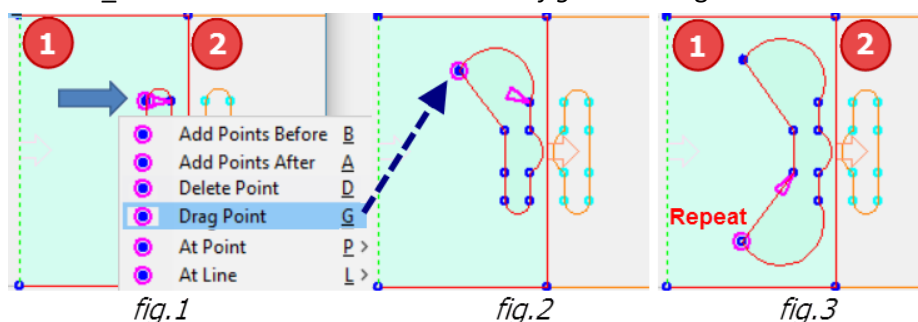

- Repeat** on Pt6 as shown in *fig.3*.

Notice that the changes to the slot in the first section **1**, do not affect the corresponding section **2**. This is highlighted in 3D view → where the box is folded. It shows the slots do not have the same shape.

This demonstrates the reason why you need to make all changes *before* you go into construction view.

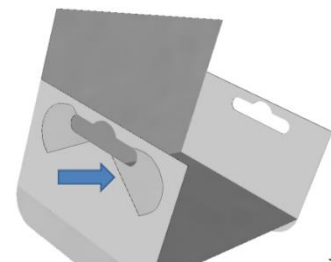

Note: We will be using the box we have created in this tutorial in [Tutorial 110 Dimensions](#).

Construction View

By converting to Construction View you now have the freedom to move points around anyway you choose. Also, all the stretch flags, by default, have been change in proportion.

This means that if you resize, you will get proportionally sized point positions, although the arcs do not change curvature.

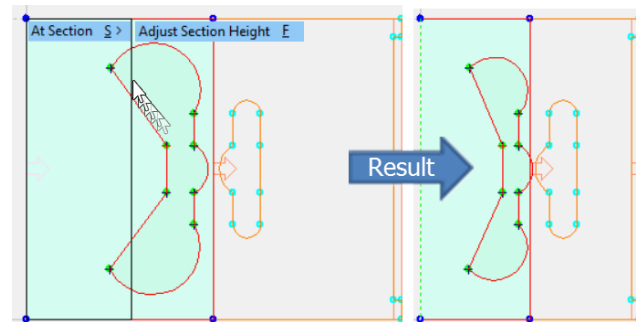

Lock / Unlock

Another way to accomplish the same thing is to use the [Auto-Lock](#) function. When you Unlock  the section, it will unlock imports and formula sections. This means that you will have the ability to do make any changes to points, without converting to Construction View.

Left click to toggle between **Lock**  / **Unlock** .

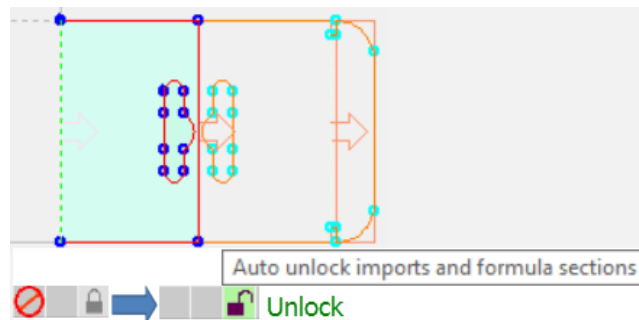

However, doing this has [consequences](#).

Imported Sections

The following are all the available sections that can be imported via the [drop down menu](#).

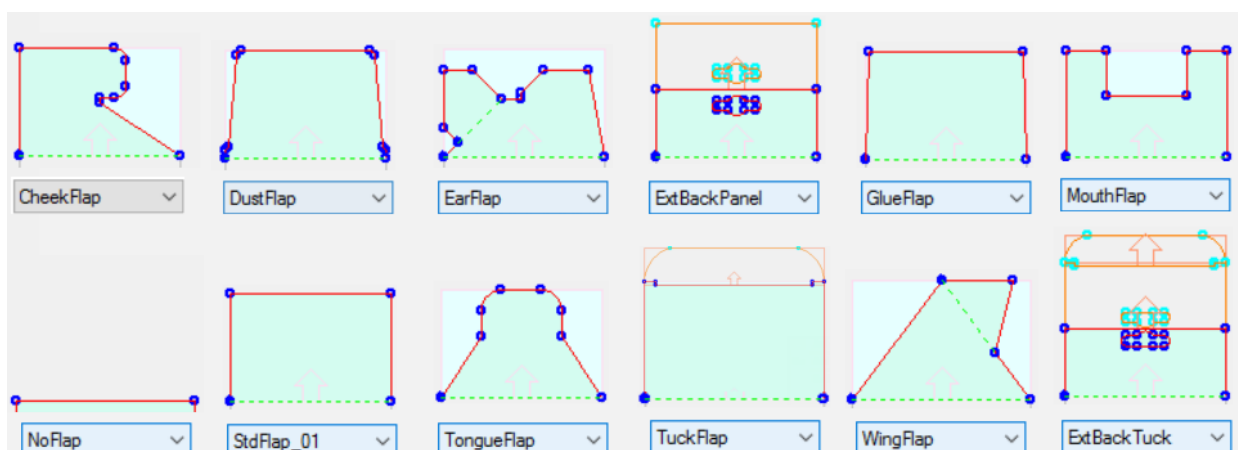

FreeForm Tutorial 110 – Dimensions with Annotations

This tutorial is about annotating your box using dimension and arrow machine steps. These are expressed in the DXF file* but do not result in cutting or folding.

* A DXF file is a file format understood by many graphical packages and is generated to send to your machining software – refer to [Tutorial 204 DXF Cutouts](#).

Tutorial Video  [Annotation](#)

Step 1

Open File

We will use the box that we created in tutorial 109, so either...

- open the file you created or
- open the '09- annotation.fs' file from the [website](#).

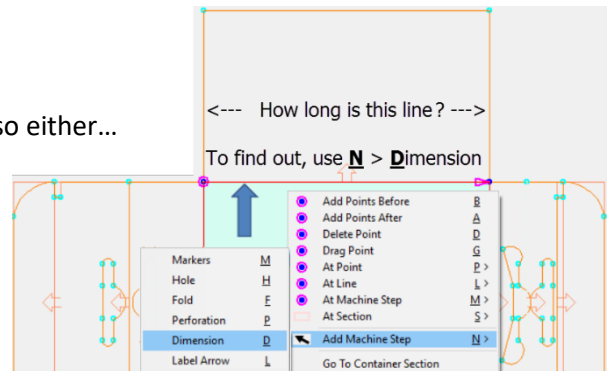

Step 2

Dimension

To find out how long your line is...

- right click on the line, as shown above, and
- from the context menu, select Add Machine Step **N** > **D**imension
- This is 3 step process...
 1. Click somewhere above the line (exact position is not important).
 2. You will notice that as you approach the point, there will be a black line from where you first clicked moving with the cursor which will change to an +. Left click on point (2).
 3. Now move to right to the other point (3) and right click to terminate.

You will see the resulting dimension line and the numerical measurement. (Shown here = 300)

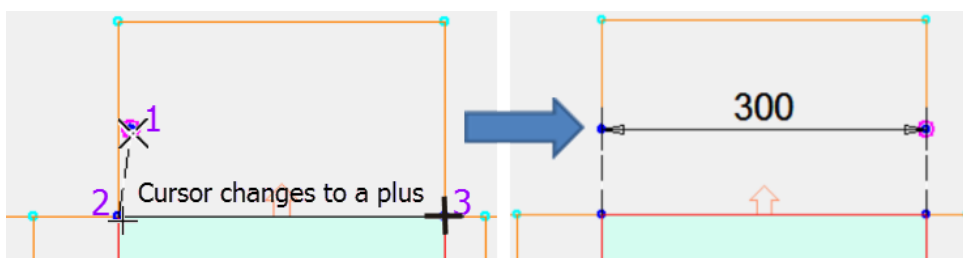

Step 3

Format Machine Step - Dimension

There is also the ability to change the format of the machine step...

- right click on the line, as shown, and
- from the context menu, select At Machine Step **M** > Format Machine Step

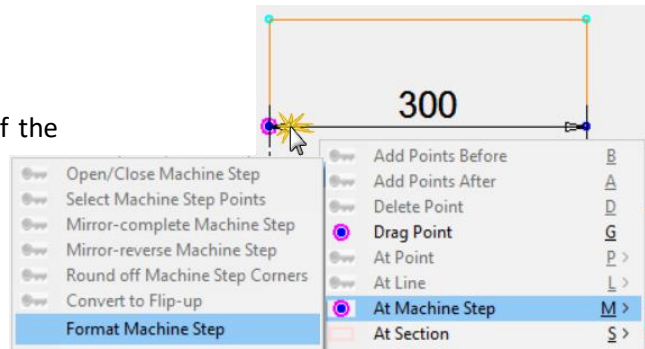

This opens a dialog box where we

- change the Numeric Format using the drop menu
- as shown, to '%.3F' which means 3 decimal points
- 3 means 3 decimal points (if not an exact measurement – see image below)
- Capital **F** – shows millimeters i.e. **mm**
Small **f** doesn't

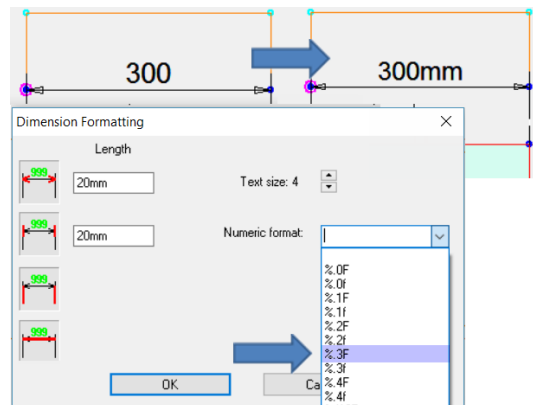

You can also change the text size and the characteristics of the arrows and whether there are arrows or not.

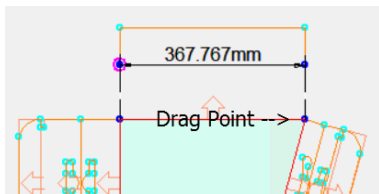

← If we drag the point of Active Section as shown left, the resulting dimension is shown to 3 decimal points i.e. 367.767mm (%.3F)

Notes on Dimension Formatting

On every dimension line you use, a label is placed along it showing how long that section of the line is. These labels do not usually show units, i.e. the label on a 147.29 cm dimension would just be "1472.9" (depending on the default Length Units you have selected), and would look like this:

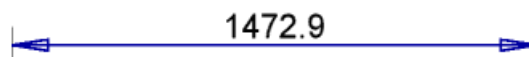

By using a *format string*, we can show a different number of decimal places or fractions and can also choose to display the units which is a special text code containing formatting information.

Format strings must start with a % sign and must end with the letter 'F'. Using a lower-case 'f' indicates that units should not be displayed (this is the default), and a capital 'F' makes units visible.

The general structure of a format string used here is: % [remainder] [precision] <show units> where:

- remainder is the period
- precision is zero or a positive integer
- show units is either an upper or lower-case 'F' character



The four icon buttons on the left are **on/off controls** used to specify and display arrows, ticks, stems or lines on the end of dimension lines. Note only two options are needed to control length.

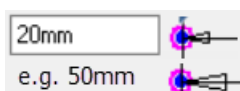

The edit box on the right sets the length of the arrow heads which is in real-world dimensions, so a typical value may be 20mm.

Step 4

Dimension Multiple Lines

We want to create multiple dimension lines but if we start at the far left corner, as per image, all dimensioning created after this will be on an angle. Also see Step 5.

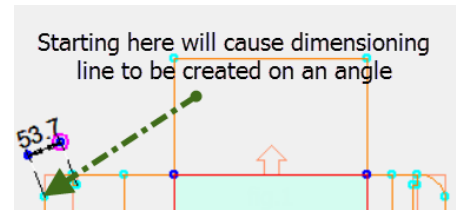

Starting at the section shown in **fig.1** below...

- right click and from the context menu, select Add Machine Step **N** > **D**imension
- left click – repeating 3 click process discussed in Step 2 (result will be 78.4)
- next left click on LH point shown **fig.2** ✕ (marked 2nd) below (result will be 43)
- then left click on RH point shown **fig.2** ✕ (marked 3rd) below (result will be 78.4)
- continue to left click until you complete dimensioning (as shown **fig.4**)
- right click to terminate.

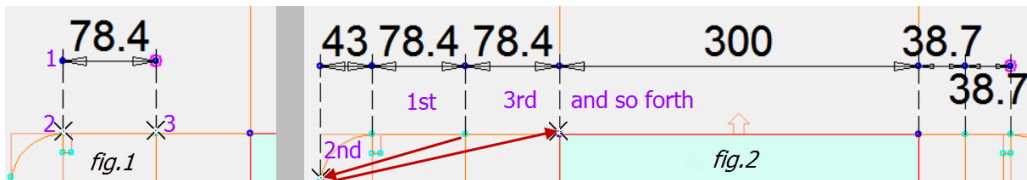

Step 5

Dimension Formatting and Align to Axis

As previously stated in Step 4, the angle of the dimension machine step is determined by the first two points selected, as shown below left. You can also see that the text is a little large, so from the context menu, select At Machine Step **M** > **F**ormat Machine Step and decrease the **Text size** from 4 to 2.

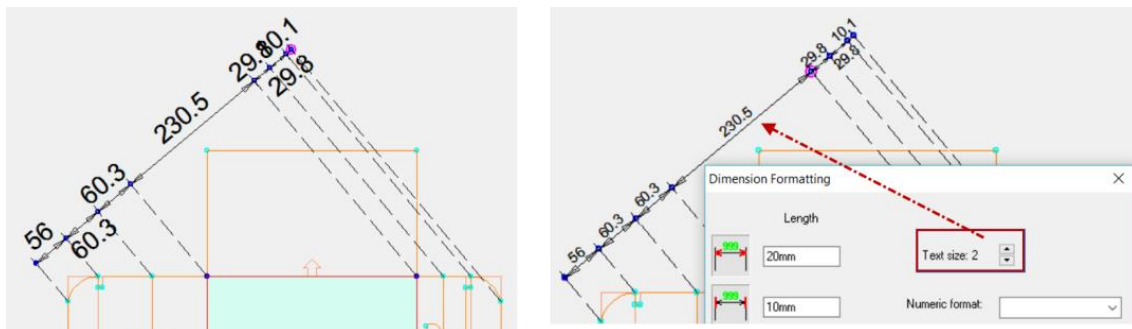

We can straighten the machine step (**fig.3**) by...

- select point indicated and from the context menu, use the **Drag Point G** command (**fig.1**)
- press the 'period key' to open dialog (**fig.2**) and press 'Align to axes' and OK

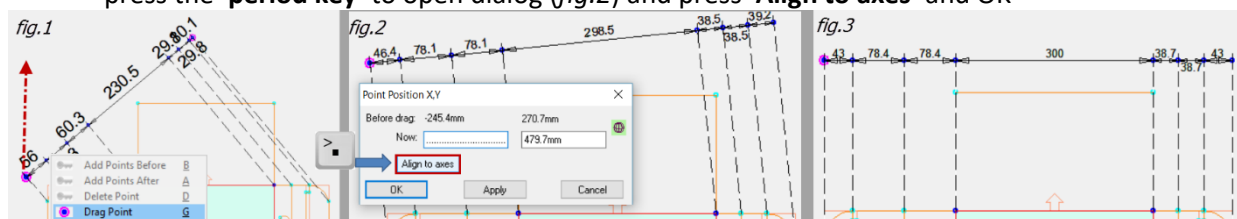

NB: The dimensions in **fig.1** are different measurements to **fig.3** but the Machine step is not changing at all. The reason for the difference is that you are dropping perpendiculars onto three different angled lines and as the dim line angle changes, so the separation of the stems change.

Step 6

Point Position X,Y

The Global symbol pointed to here, allows you to make the alignment to local axis if it happens to be different to the global ones.

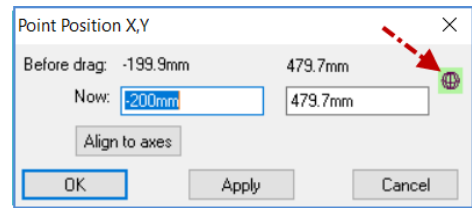

Step 7

Add Label Arrow

To add a label simply ...

- select Add Machine Step **N** > Label Arrow **L** from the context menu
- left click where you want the label to go (*fig.1 - 1*)
- left click where you want the arrow to go (*fig.1 - 2*)

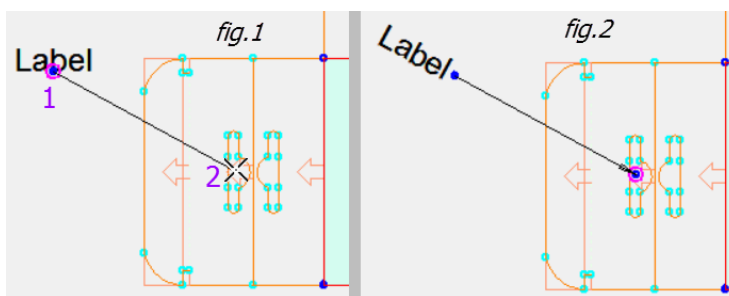
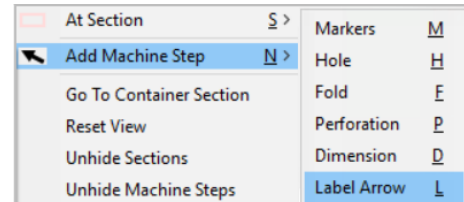

Note that the Main Section is Active and annotations can be added to any section of the box but still pertain only to the Main Section (see Notes on Annotation, next page).

Step 8

Label Arrow Formatting

To format the arrow from the context menu, select At Machine Step **M** > Format Machine Step to...

- turn **Arrows** On/Off (*fig.1*) using AB buttons
- change the **Length** and **Width** of Arrows.
Compare: *Fig.1* Length = 20mm Width = 6 mm and *Fig.2* Length = 50mm Width =15mm
- change **Label** text (*fig.1*) to Slot A
- change **Text angle**. Compare: *Fig.1* 90 degrees to *Fig.2* 29 degrees
- change **Text size**

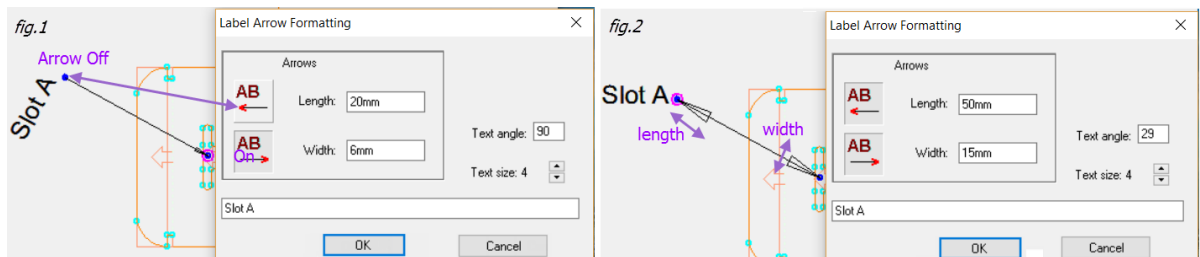

Notes on Annotations

Note that the annotations only pertain to the Active section, which in Step 7 is the Main Section. However, you can add annotations to one section or individual sections as it makes no difference to their expression in the DXF file.

If you select a different section then the annotations grey out →

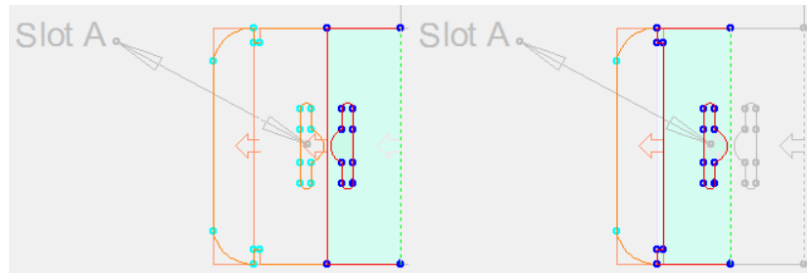

Step 9

Send to Flexi

Now press the 'Send Box' and, as you can see below, the annotations are expressed in the DXF file.

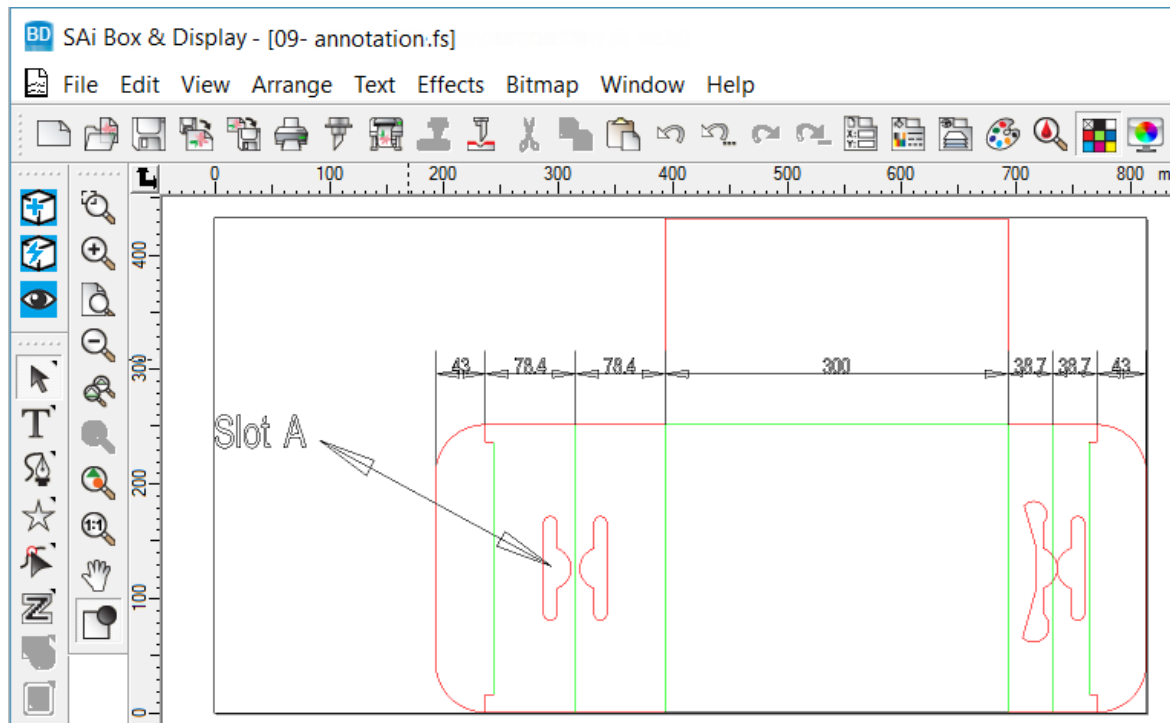

FreeForm Tutorial 111 – Making a Flip Up

This tutorial is about creating flip ups which is a common feature of point of sale boxes.

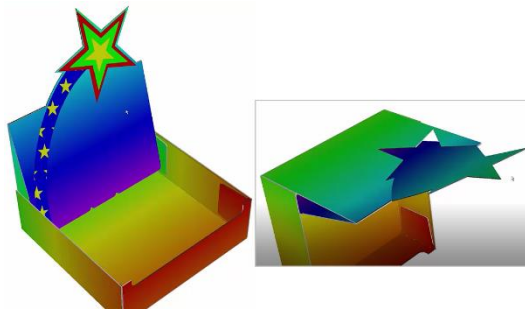

This is a typical flip up here with a piece cut out of an adjacent section which doesn't fold down but remains pointing up.

Tutorial Video  [Making a Flip-Up](#)

Step 1

Open File

Open the '10- flipup.fs' file from the [website](#) –The following shows in Construction View.

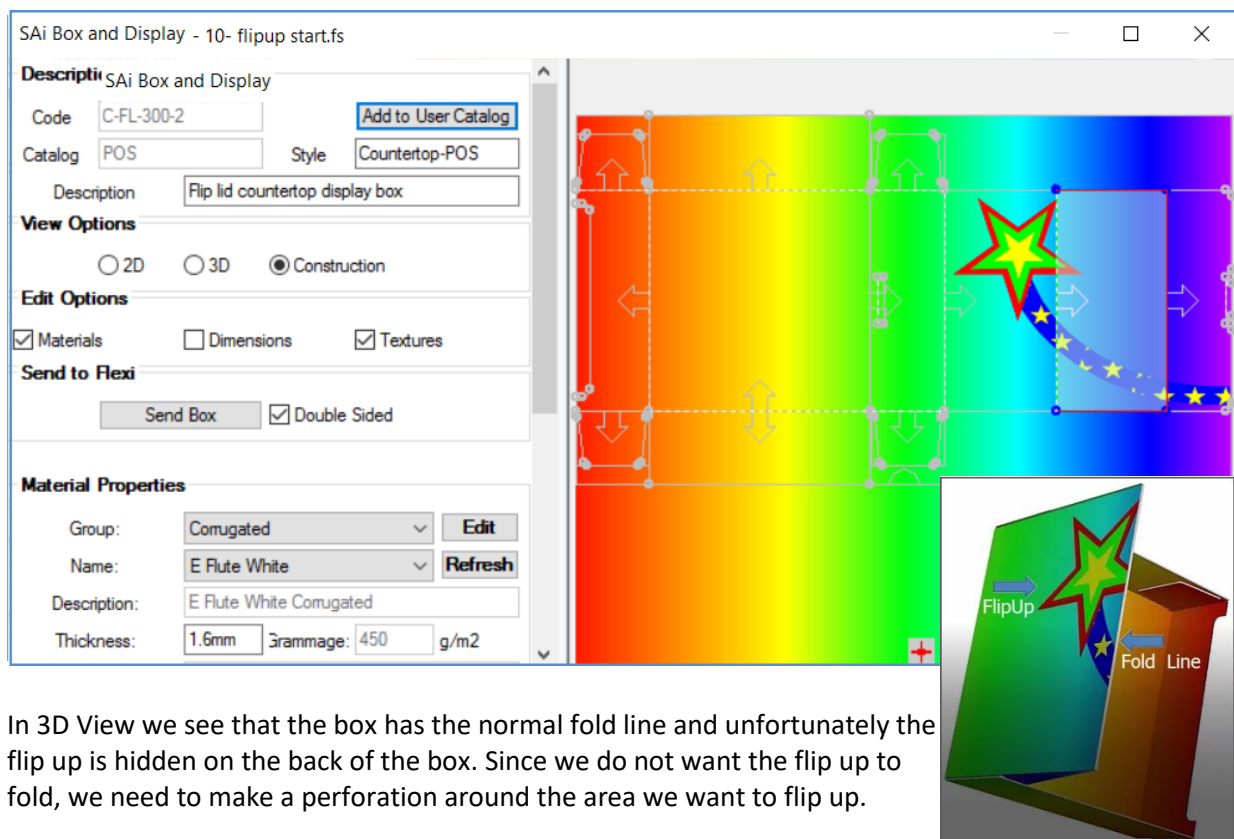

In 3D View we see that the box has the normal fold line and unfortunately the flip up is hidden on the back of the box. Since we do not want the flip up to fold, we need to make a perforation around the area we want to flip up.

So, to fix that we go back into Construction View.

Notes on Flip Ups

It is **important to note** that perforations can only be done *outside the current Active Section*.



Step 2

Perforation Machine Step

Flip ups are made with a perforation machine step.

Remember that perforations can only be done *outside the current Active Section*, as shown.

- Select the section shown, in the image, to make Active.
- Right click and from the context menu, select Add Machine Step **N** > **Perforation**

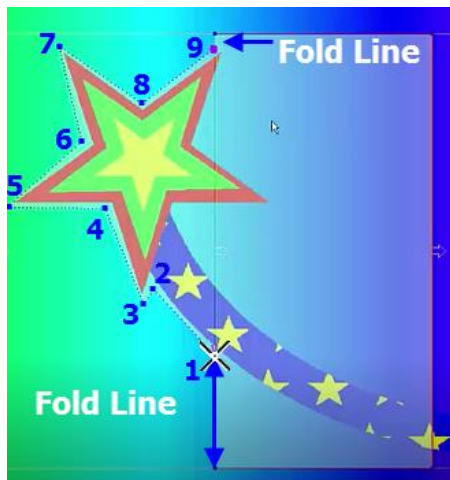
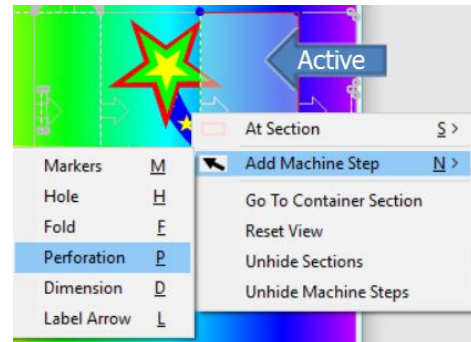

NB: This machine step has to have its two ends on the fold line. This is shown on the image on the left. There is a small fold line on the top and a larger fold line on the bottom. [Tip: Zoom in for better view]

Start perforation cut out, as shown **number 1**. The cursor changes to \times , left **click at the 2nd point** and BD will automatically close the selection with a straight line. Continue as shown for **all 9 points** for perforation.

Terminate when completed at top fold line with **right click**.

NB: You can **Drag Point G** later, if any of the points don't exactly end up in the required position.

Step 3

Convert to Flip Up

- Now right click on a point of the perforation
- from the context menu, select At Machine Step **M** > **Convert to Flip-up**

Note perforated lines change to **red** lines i.e. machine step.

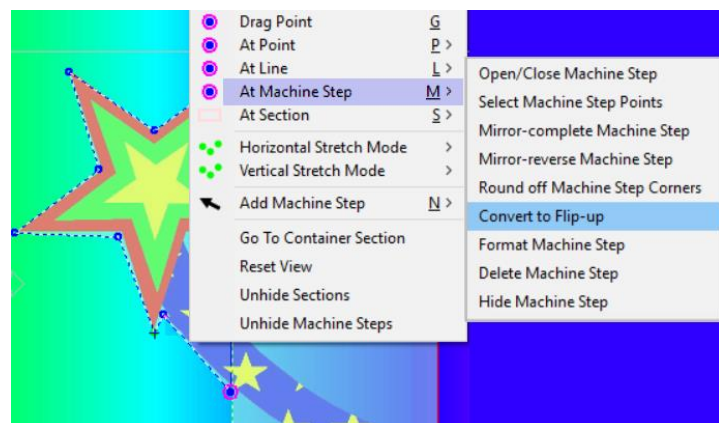

It is possible that you get an error stating that one or both points are not on a foldline, as shown. In this example, you can simply can **Drag Point G** but if required, to reduce the finicalness of the test, just Zoom Out.

View in 3D to see result.

See also [Tutorial 205 SuperMan Flip](#) – adding curves.

FreeForm Tutorial 112 – Rivet Holes

In this tutorial we are going to make a square box and add rivet holes to hold the box together.

Tutorial Video  [Rivet Holes](#)

If you want to skip Steps 1-6, which creates the box, go to the [website](#) and open [11- rivetholes.fs](#)

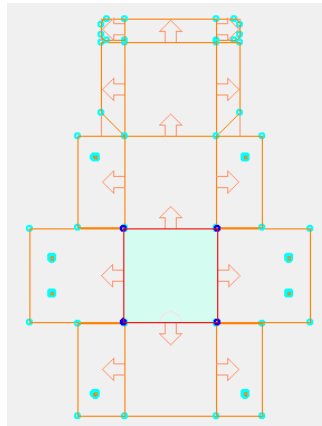

Step 1

New FreeForm project

- From the Flexi tool bar, select **New** 
- It takes a moment for the project to load.

Step 2

Edit Option - Materials

- Click on the **Materials** check box
- From Material **Group** dropdown, select Corrugated.
- Select a **B Flute** as shown.

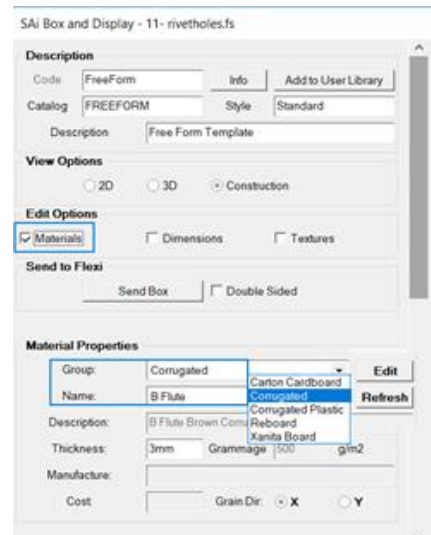

Step 3

Starting your design

- Click on the **Dimensions** check box
- **Set Dimensions**
Change the Base Line Width from 300mm (default) to **304.8mm** (12inches)
Set Quick Entry (1) 304.8mm (2) 150.8mm (3) 76.2mm

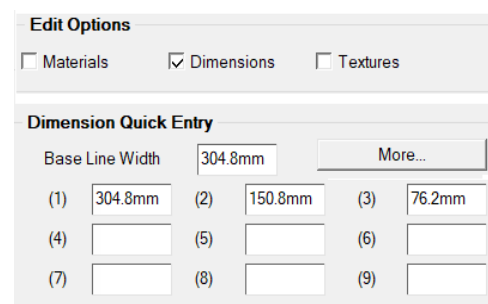

Step 4

Create Main Panel – Basic Flap

- **Right click** on the **Base Line** to bring up the context menu
- Select At Line **L** / Add Basic Flap **F** and press Quick Entry Dimension (1)
This will create a cube i.e. **flap 1** shown in diagram, next page.

Step 5**Copy this four times**

Now you just need to add 4 more flaps, of the same size.

To achieve this, you can simply make **flap 1** Active, then...

- **Ctrl+C** to copy flap 1
- **select the line** where you want to adhere it to and **Ctrl+V** to paste, creating **flap 2**
- **left click** to complete flap

Repeat for flap 3, 4 and 5 as per diagram

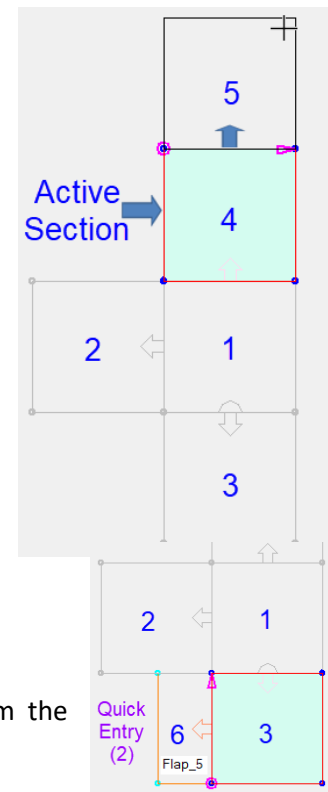
**Step 6****Add Flap 6**

Now add a 150.8mm flap to **flap (3)**

- Make flap 3 Active and 'At Line' / 'Add Basic Flap'
- Hold down Quick Entry (**2**) key and move your **mouse left** from the selected line and **left click** to complete.

Step 7**Add Rivet Hole to Flap 6**

- Select the last flap created. The status bar will display **Flap_5**
- Click on '**Snap to Grid**' and right click to open Grid Spacing edit box, as shown. Change the spacing to 4.8mm
- Zoom in and since we want to make the hole relative to the flap, click on coordinates globe to make local (will display as greyed out)
- Locate 20 points across and 15 points up. The image below shows what we want to achieve.

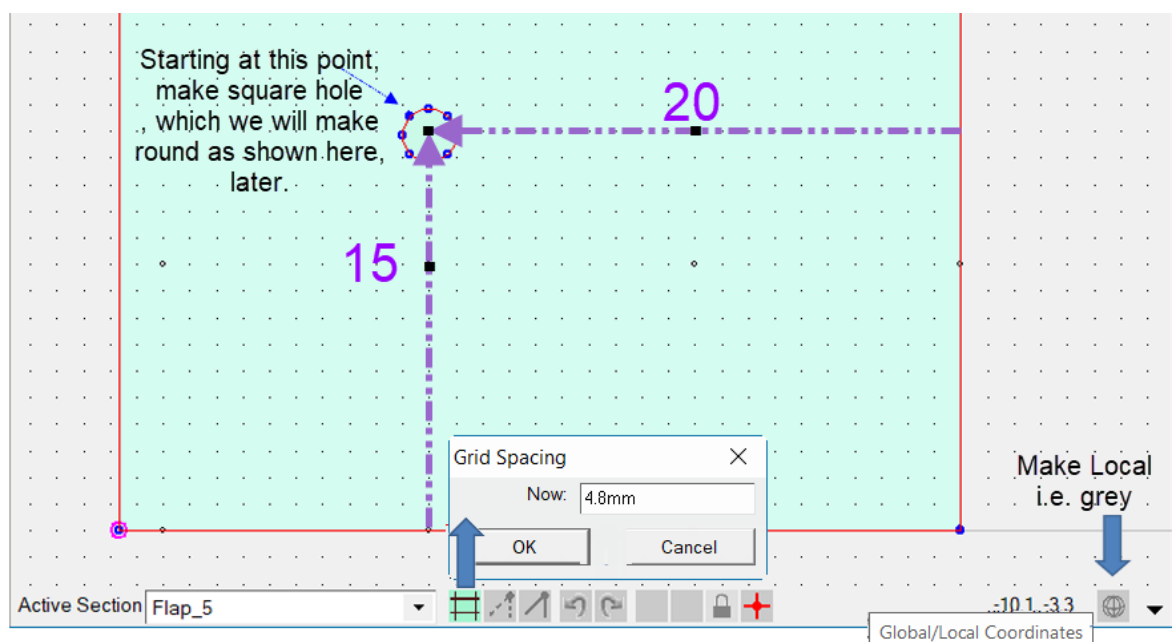

- Right click on preview pane and select [Add Machine Step > Hole](#) from context menu. (1)
- An **X cursor** will display (2), just left click at required intervals to form a square (2 – 5).

Snap to Grid will constrain the line to last point and keep straight but you can also **Hold down** the 'shift' key while creating the square.

- When complete, right click on a machine step of square and from context menu, select '**At Machine Step / Round off Machine Step Corners**' to make the rivet hole required.

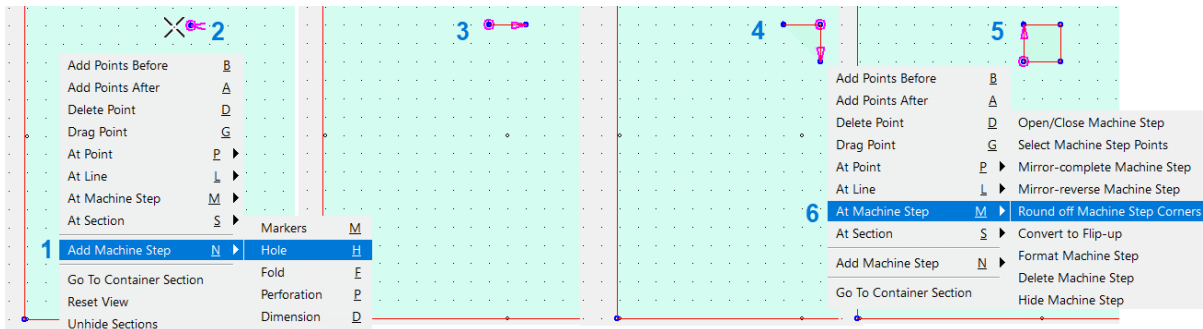

Step 8

Copy Flap with Rivet

- To copy, (1) make flap **Active** and (2) use **Ctrl+C**.
- (3) make the flap that you want to add flap to **Active** and select line (4) and **Ctrl+V** to paste.
- As shown below right, the flap is ok except that the rivet hole is in the wrong position.

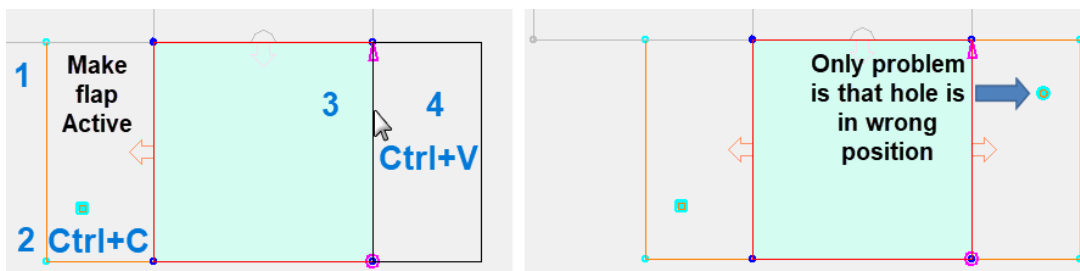

Step 9

Mirror-reverse Machine Step

- To move rivet hole to correct position, make left flap **Active** and select a machine step on hole.
- Right click and select '**At Machine Step / Mirror-reverse Machine Step**'

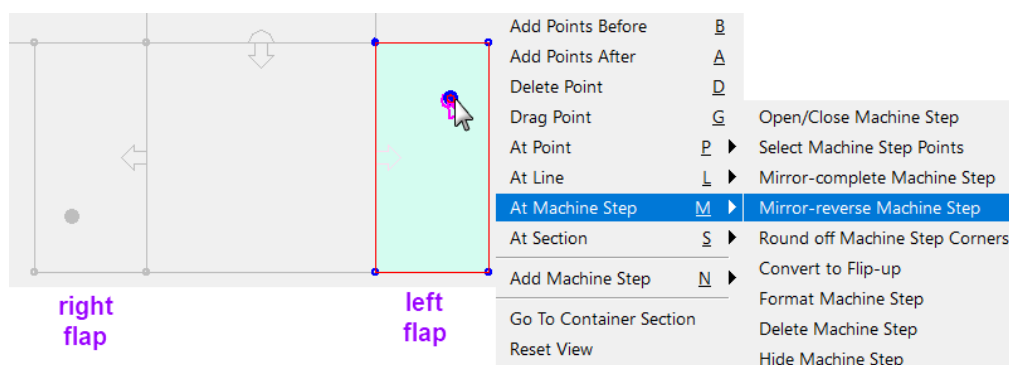

Step 10

Edit Offset

- To allow for folding, we will offset the flap by the thickness of the material.
- Select the **right flap** and make **Active** and click on the **Edit Offsets** button, as shown.

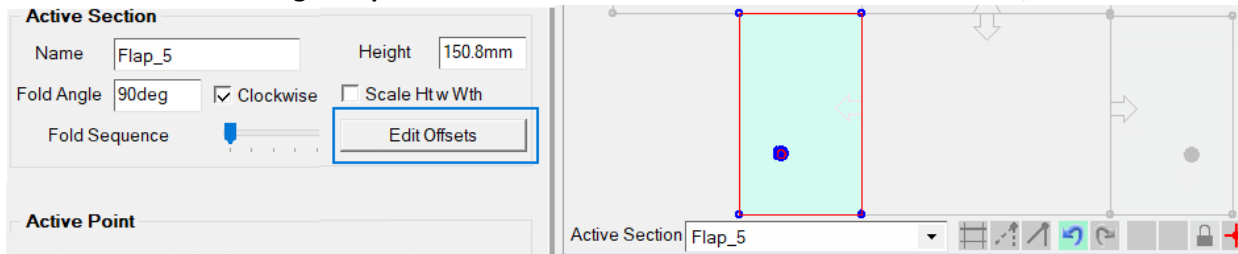

- In the presented dialog, select Flap/Panel from the dropdown menu that you want to offset, in this case, **(3) Right** and tick the checkbox **Right** as shown.
- Repeat** for left flap i.e. make **left flap** Active and select **(2) Left** and tick **Left** checkbox, shown.

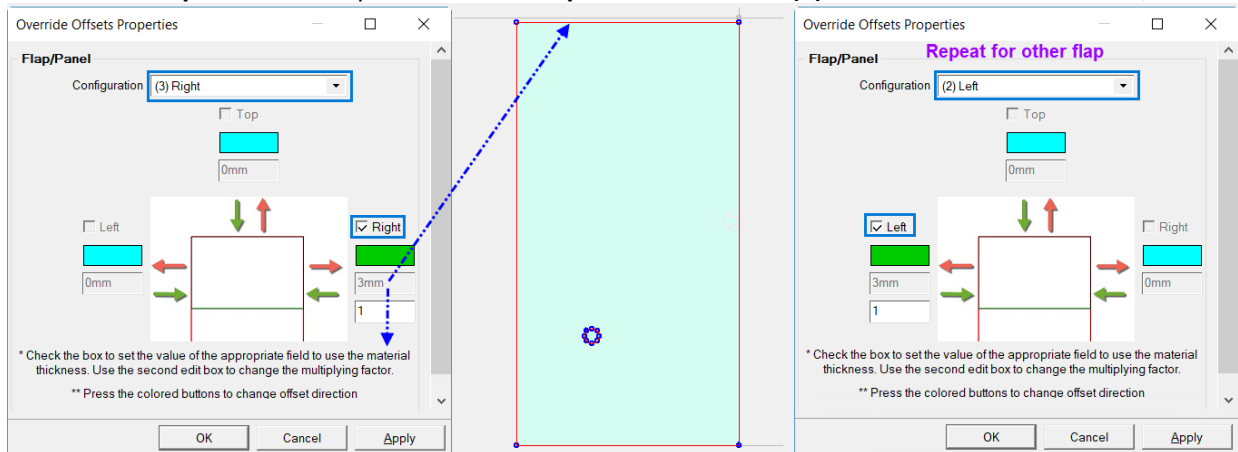

Step 11

Copy the Offset Flaps

Now we want to copy these two offset flaps to Flap_3 as shown.

- Copy right** flap and **Paste on left** side of Flap_3
- Copy left** flap and **Paste on right** side of Flap_3
Note only one section can be active at a time.
Diagram is only to show what we are trying to achieve.

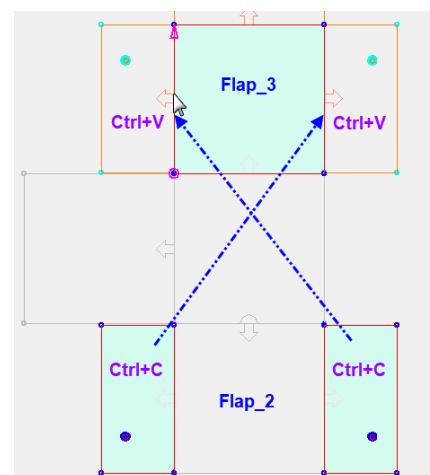

Step 12

Offset Flap_2 and Flap_3

Repeat Step 10 Edit Offsets for both these flaps.

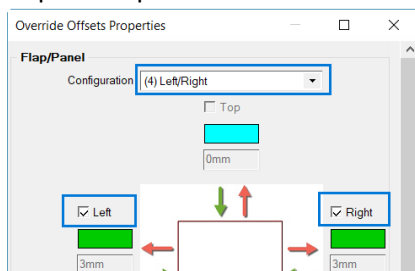

For both flaps select **(4) Left/Right** from dropdown menu and tick the **Left** checkbox and the **Right** checkbox, as shown

Step 13

Add Rivet Holes to Flap 1

Now we are going to add two rivet holes to Flap_1, in the same way as Step 7.

- Make flap Active and ensure that you still have 'Snap to Grid' on.
- Zoom in and since we want to make the hole relative to the flap, ensure coordinates globe is local.
- Locate 20 points up and 15 points across as shown.
 - 'Add Machine Step / Hole'
 - 'At Machine Step / Round off Machine Step Corners'
- **Repeat** rivet hole on top edge of flap, **20 points down** and **15 points across**, shown below right.
- **Copy** this flap to other side to create Flap_9 with matching rivet holes.

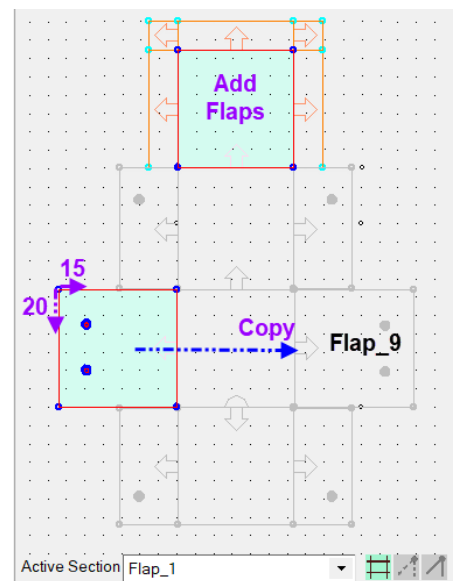
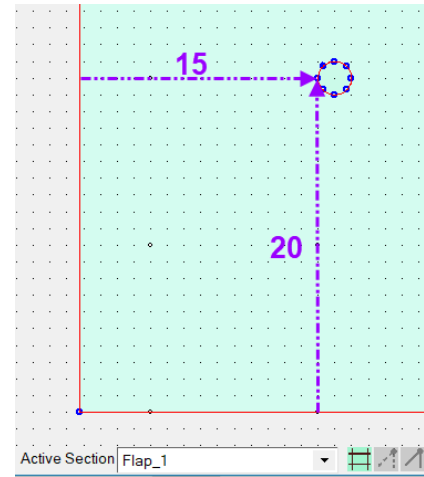

Step 14

Add Basic Flap to Flap_4

Now we will add flaps to the top panel/flap as shown.

- Make top flap active and right click to get context
 - **At Line / Add Basic Flap**
 - Use Quick Entry Dimension (**3**)
- Use either Copy/Paste or use Ctrl-R to repeat adding same size flaps as shown.

Step 15

Chamfer Corner

Now we will chamfer the corners

- Make flap shown active and right click to get context
 - **At Point / Chamfer Corner**
 - Use **full stop** key to open Corner Dimensions edit box and **type in 76.2mm**
 - Click on **Point** to Chamfer on other side and use **Ctrl+R** to repeat.

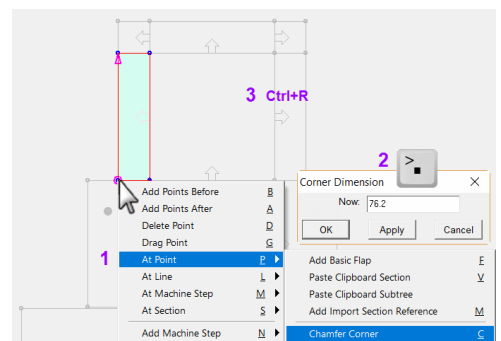

Step 16

Offset tabs

Repeat Step 10 Edit Offsets for **both** corner flaps – Offset (2) Left and then (3) Right by 6.4mm

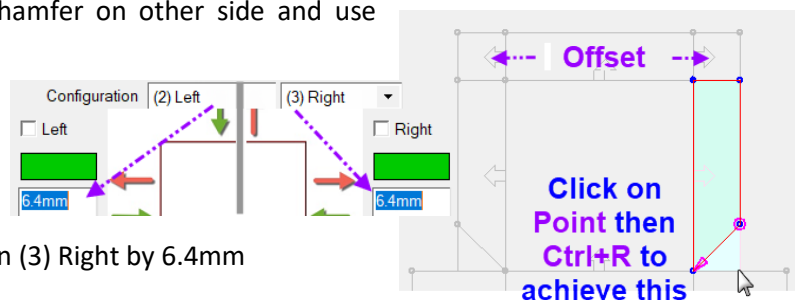

Step 16

Fillet Corner (rounded)

To fillet the corners...

- Make flap shown active, select **Point** and right click to get context
 - **At Point / Fillet Corner**
 - **Move cursor until you get required fillet**
- Select **Point** and use Ctrl+R to repeat the fillet on the other corner of same flap
- Use Ctrl+R in same way on right hand corner flap.

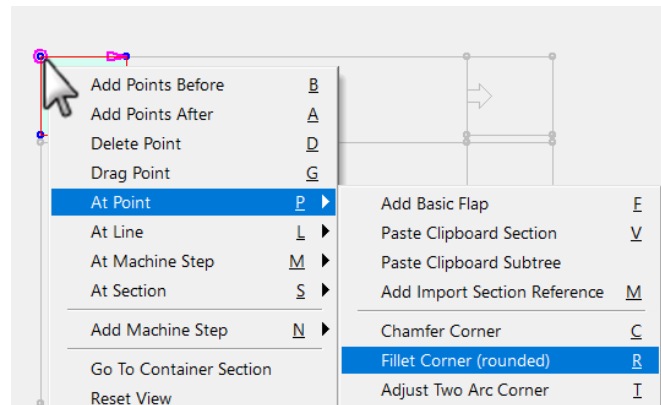

Result

The image shows the result in 2D and 3D view respectively.

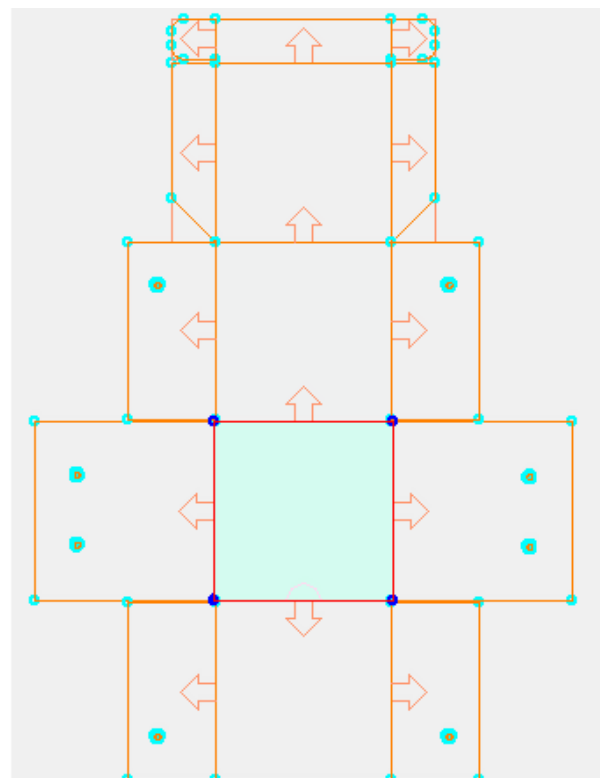
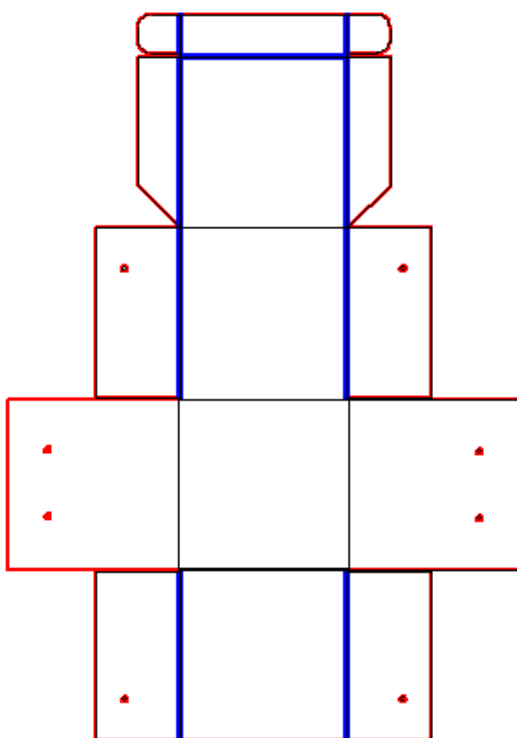

FreeForm Tutorial 113 – Add Tab, Notch or Slot

In this tutorial, we will 'Split a Machine Step' and then add tabs, notches and slots.

First create a 300 x 200 rectangular section and 'Add Basic Flap' with a height of 150mm.

Then, select the top left point and either ...

- [drag](#) the Active Point down to 50mm from bottom to make a sloped line

OR

- use the Active Point edit box to accurately place.

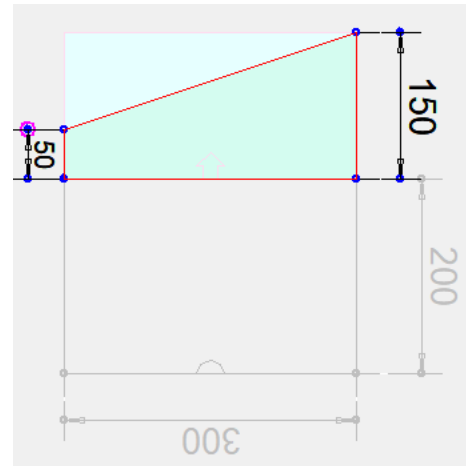
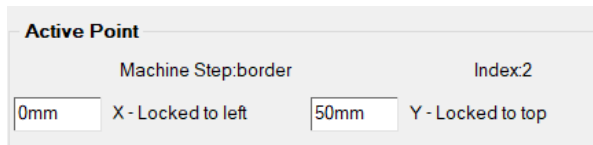

Split Machine Step

This command provides the ability to simply open up a machine step polyline putting a gap at a place that you choose.

In many cases this split will be done automatically for you as part of other commands (like adding flipups or tabs) but occasionally you may want to split a polyline machine step into two pieces before further editing.

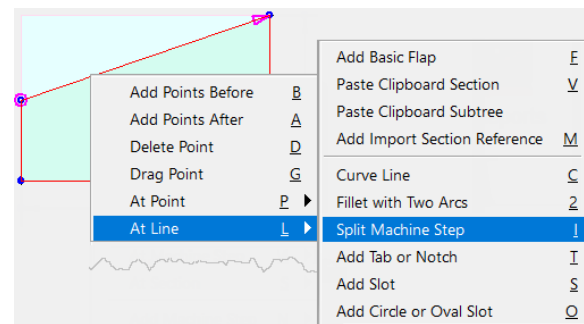

To do this, use the '**At Line > Split Machine Step**' from the context menu, as shown. The 'Split Machine Step' command breaks a machine step at a point on the active line. Two new points are added, creating a little gap, which is constrained to move along the active line as you move the mouse. Left click to complete the command.

Result: The cursor is connected to the two points by a rubber band line. This allows you to change the size or position of the machine step by simply moving the cursor, as shown in the images below.

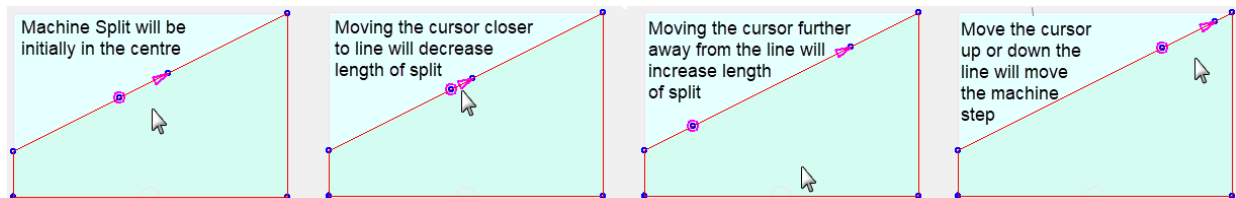

To enter the coordinates for accurate measurement, press the '**period / full stop**'  key. This opens a Precision Input dialog, discussed on the next page.

A Precision Input dialog box provides a button to **centre** the machine step and dimensions of the line. Example shows...

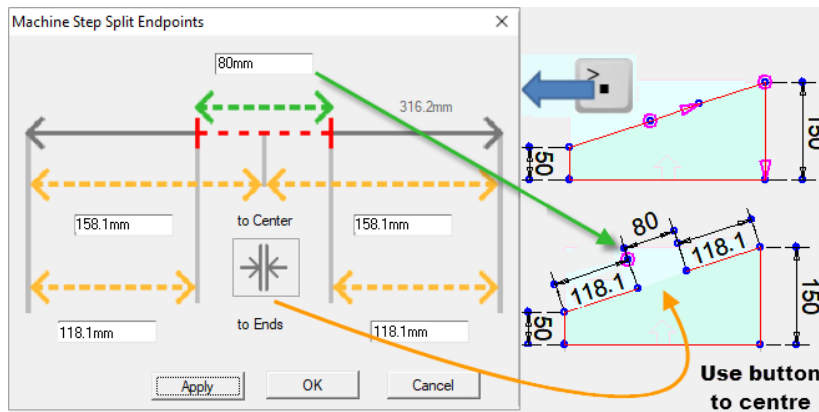

- Total Length: 316.2mm
- Distance to Centre: 158.1mm
- Distance to Ends: 118.1mm
- Machine Step width: 80mm

Use Edit boxes to change dimensions and hit the 'Apply' button to see changes.

OK button will save changes and exit dialog.

Add Tab or Notch

A tab and/or a notch can be created in a similar way. To do this, use the 'At Line > Add Tab or Notch' from the right click context menu, as shown.

Result: A tab will be created which can be repositioned by moving the cursor up or down the selected line.

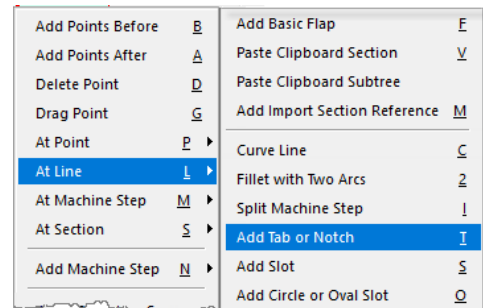

To open the Precision Input dialog, press the 'period / full stop' key.

The only difference to the 'Split Machine Step' dialog discussed on the previous page is it has an added **height** edit box.

In the example below, **tab 1** was created with a width of 50mm and a height of 25mm. It was then positioned 40mm from the left end.

Tab 2 was created in the same way but you will notice that *the width and height of the tab is remembered*. Every subsequent tab or notch created will be reproduced in this manner until either measurement is changed or the current Box&Display session is terminated.

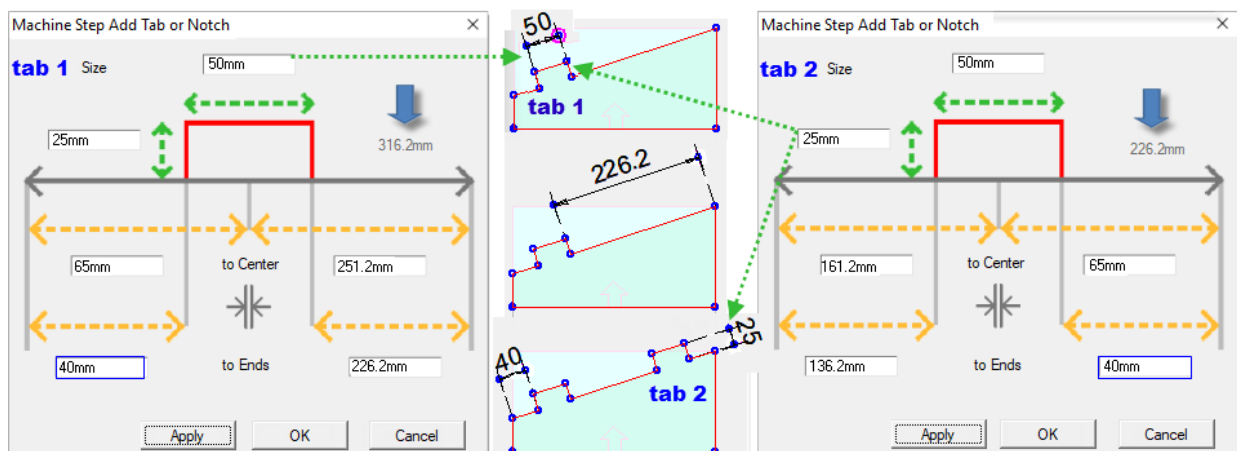

A **notch** is created simply by changing the height measurement to a negative number.

In the example shown, the height of tab 2 was changed to **-25mm** to change it to a notch, which is now remembered for subsequent creation.

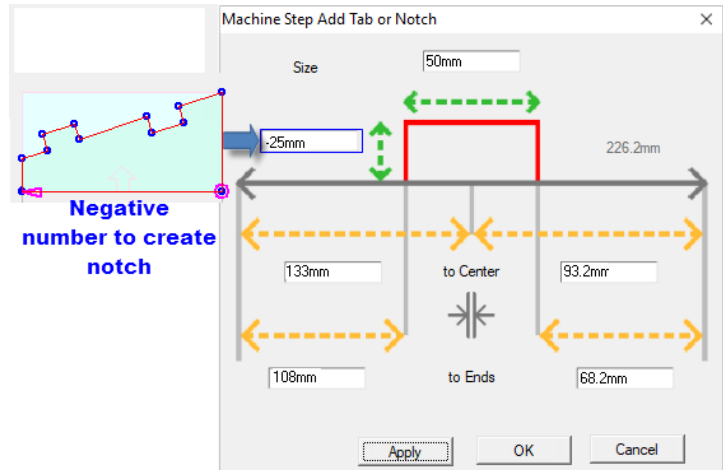

Add Slot

To add rectangular slots use the 'At Line > Add Slot' from the right click context menu, as shown.

Result: A rectangular slot will be created which can be repositioned by moving the cursor up or down the selected line.

Like the 'Tab/Notch' width, height and offsets are remembered. Every subsequent slot created will be reproduced in this manner until either measurement is changed or the current Box&Display session is terminated.

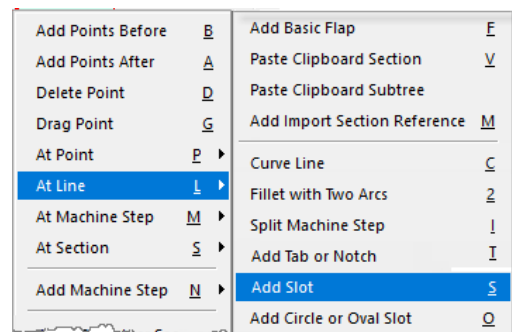

To open the Precision Input dialog, press the 'period / full stop' key.

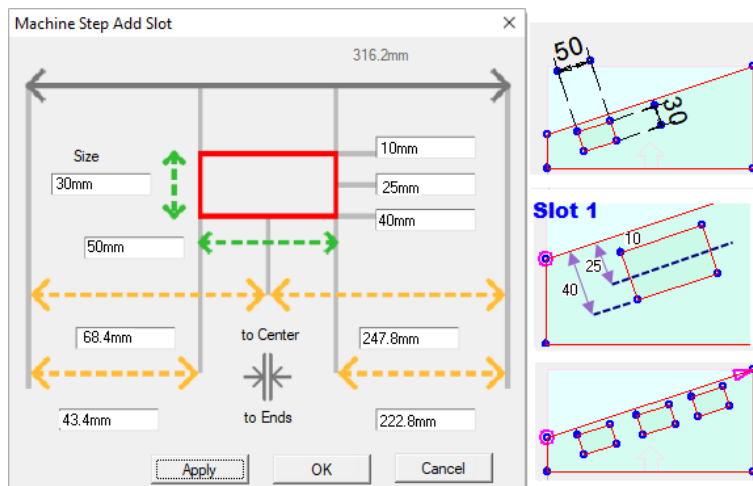

This dialog, like the 'Add Tab or Notch' dialog has edit boxes to control width and height.

In addition, there are three extra edit boxes that control the **inner/outer/center** line offsets.

This example shows the position of the slot set **10mm** from the selected line. The **center line** is **25mm** from the selected line and finally the **outer line** is **40mm** from the selected line.

Note: These offsets all interact. It creates the extra Hole machinestep and puts it in the "-Cut" layer (or uses whatever you specify as _mscutlayer).

Add Circle or Oval Slot

To add a Circle or Oval slot use the 'At Line > Add Circle or Oval Slot' from the right click context menu.

Result: A circle/oval slot will be created which can be repositioned by moving the cursor up or down the selected line.

In this example, we have created ...

- a circle i.e. 50mm x 50mm wide
- a slot i.e. 10mm x 50mm wide

Deleting Tabs, Notches or Slots

To delete simply select the tab, notch or slot by using click and drag, as shown.

The result will be the presentation of arrows, which show the locking status pertaining to each point.

Hit the keyboard delete button to remove the selected tab, notch or slot.

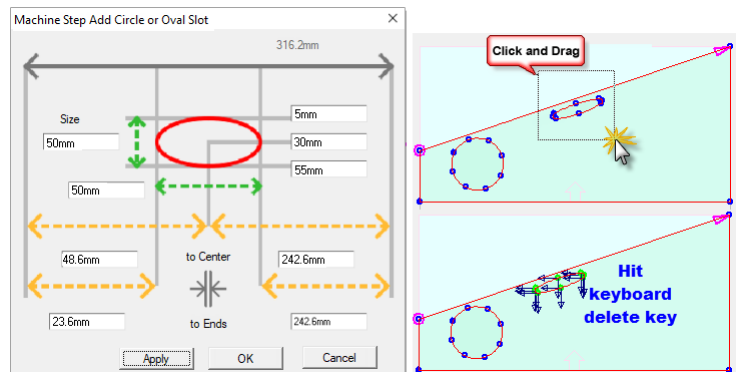

Tabs, Notches and Slots can be further amended to suit. As per the example below...

- A rectangular slot has [curved ends](#)
- A notch has its points [filleted](#) and the [line curved](#)

To see how this is done, watch [Pen Holder Display - Part 6](#) (start at the 4 minute mark)

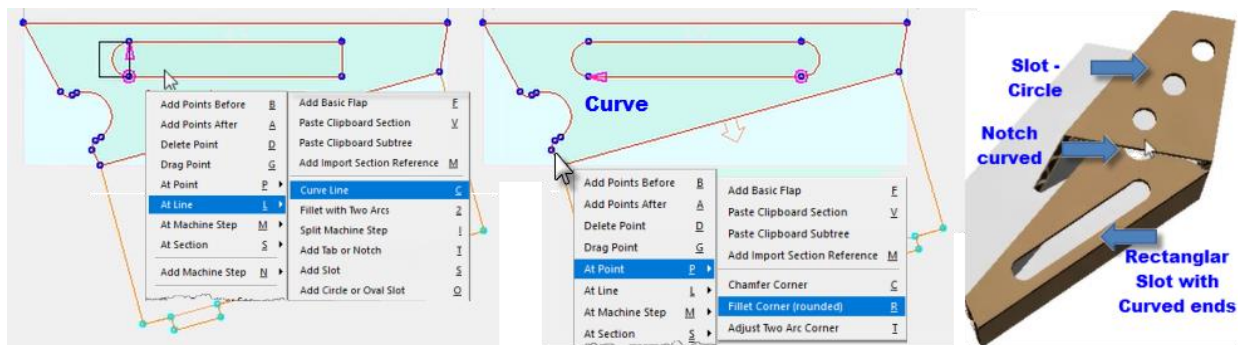

Pen Holder Display

Watch this series of videos and see how to create a pen holder with tabs, notches and slots.

Note: The creation of the pen holder is complex but is an excellent example of the power of freeform.

Video Part 1 [Design Layout](#)

Video Part 2 [Design Layout](#)

Video Part 3 [Adding Slots](#)

Video Part 4 [Adding Tabs](#)

Video Part 5 [Adding Holes](#)

Video Part 6 [Final Steps](#)

Video  Part 7 [Adding Illustrations](#)

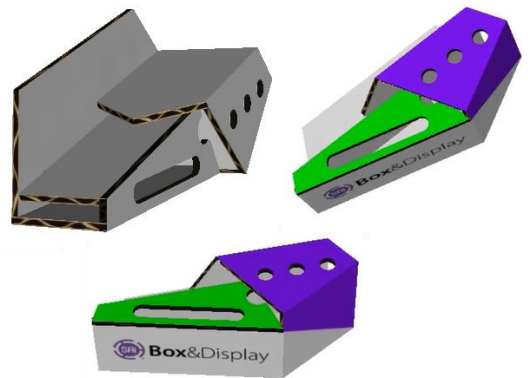
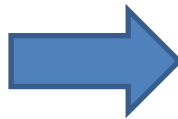
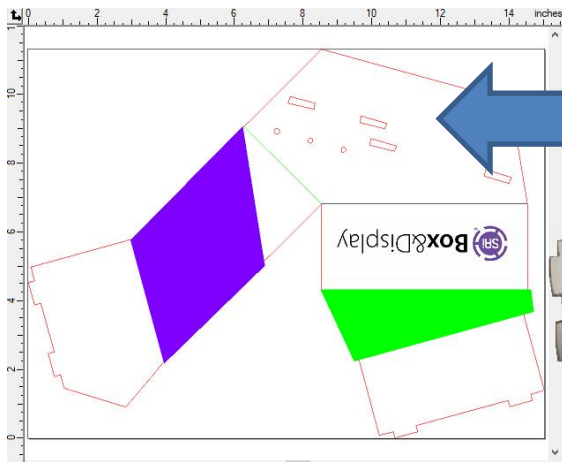

Template Tutorial 200 – Create Box FEFCO 0205

The following will create a box using a template, make some changes and then ‘Send to Flexi’.

Remember:

- **Ctrl+Click** to **follow internal link** to quickly navigate to other parts of this document.
- **Return** from a hyperlink jump by using **Alt+left-arrow** [Only with Adobe]

Step 1

Start by opening: a template

- click on the **lightning bolt**  button, which allows you to **use existing templates** which you quickly and easily modify to meet your requirements.

Browse Box Library: When you start from a template, you will see this dialog. As we want a supplied template, we will use the default ‘Standard’ library.

View Catalog button allows you to access a pdf containing details of each template

- Select **FEFCO 0205** as shown
- Click ‘**Create**’ button

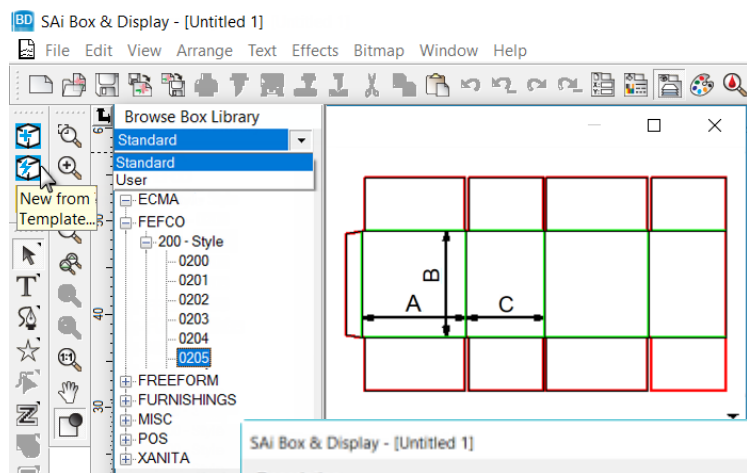

Step 2

Construction View

- Ensure that you are in Construction View as shown, so we can add a small flap to the bottom RH section as per image below.

Step 3

Select Active Section

- In the Preview pane, double click on the section shown, to make Active. You will know it is Active as the section turns to a light blue color. See [Chapter 6 - Notes on Active Section](#)
- The status bar will also give you information about the Active Section. Just left of blue arrow it is called ‘Sec4_B_Flap’.
- Left click on line shown on the Active Section, and right click for context menu.

Note: Menu options are greyed out and the No Entry  sign is shown in the status bar.

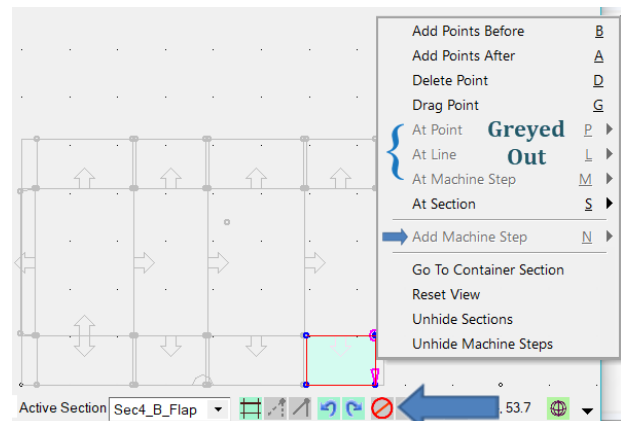

Step 4

No Entry message

When you *hover over* the 'No Entry' sign, as shown, you will be provided with a [message](#), informing you on why the active section or machine step is protected from some editing commands.

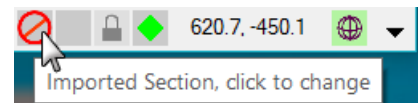

Left or right clicking the indicator usually allows the protection to be removed. To 'Convert to local copy'...

- Left click on the 'No Entry'  sign and you will get this message.
Click OK to 'Convert to local copy' message.

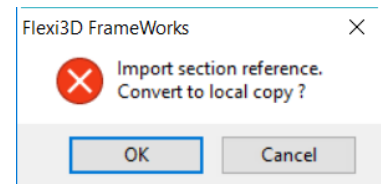

If you are just adding things to an existing flap such as attaching another little flap as in Step 3, you only need to 'Convert to local copy'.

The No Entry Sign may still be displayed stating 'Formula Section. Click to change' but Step 5 and Step 6 can be done without clearing formulas.

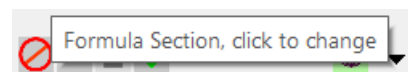

See [Chapter 4 - Consequences](#)

Tutorial Video  [Convert to Local to Enable Changes to Template](#)

Step 5

Add Basic Flap – 8mm Glue tab

Now we can add a small flap to the bottom RH section.

- Double click on the section **Sec4_B_Flap** to make 'Active' as shown (highlighted in blue)
- Right click on the RHS **line** and choose **At Line > Add Basic Flap [L > F]** from the context menu.
- Use 'period' key  to open **Section Height dialog** and enter in **8mm** and hit **OK**.

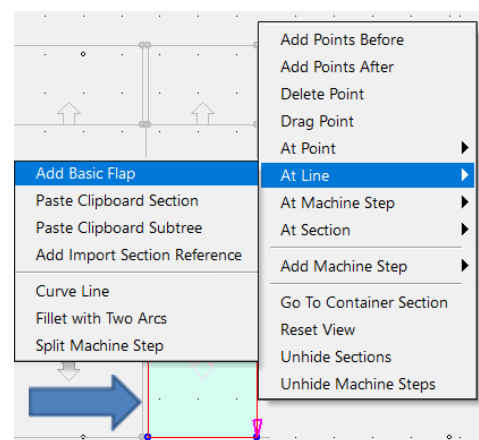
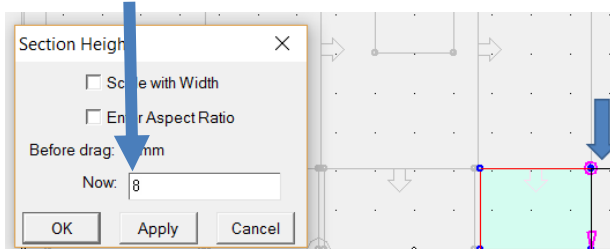

← Result. The black line first presented will change to a **red line**, indicating the resulting machine step, as shown below in Step 6.

If you want to make amendments to more sections, such as discussed in Step 6, you must 'Convert to local copy' on **all flaps** that you want amend.

Step 6

Repeat Command

You can use **ctrl-R** to **repeat** the process on the Top Flap, Sec4_T_Flap.

See [Chapter 5](#) for list of [Repeatable Commands](#).

Note: You can only repeat the last command executed, however, you can 'Convert to local' in between.

- Make 'Active' **Sec4_T_Flap** and '**Convert to local**'
NB: Only one section can be 'Active' at any one time. The diagram is only a visual reference.
- **Left click on RH line** which will change to bullseye and arrow as shown.
- Use **ctrl-R** to **repeat** i.e. adding 8mm flap, as shown.

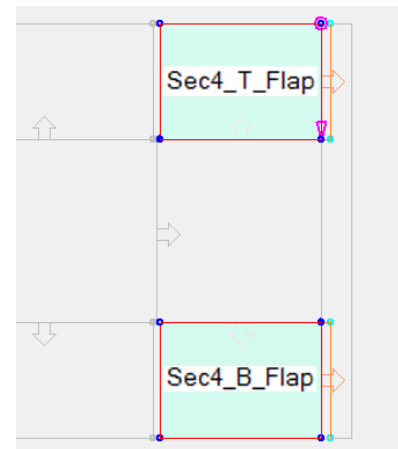

Step 7

Add Machine Step - Dimension

Dimensions can be seen in **2D** or **Construction View** by ticking the '**Show Actual Panel Dimensions**' checkbox. As shown, Edit Option 'Dimensions' must be turned on to select this.

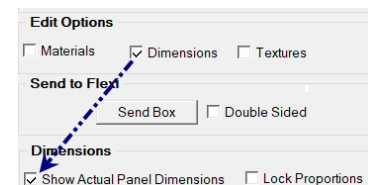

The following requires **Construction View**.

To confirm the width of the flap just created, we add dimensioning – see [Tutorial 110](#) for more details.

[Zoom in](#) to view the **Sec4_B_Flap** better.

- right click anywhere in the preview pane and from the context menu
- select Add Machine Step **N** > **D**imension, then...
 1. To **position dimension line**, click somewhere below the line (exact position is not important).
 2. You will notice that as you approach the point, there will be a black line from where you first clicked, moving with the cursor which will change to an **+**. Left click on **start point** (2).
 3. Now move to right to the other point (3) and continue for **all other points** for measurement, in this case (4). Then right click to **terminate**.

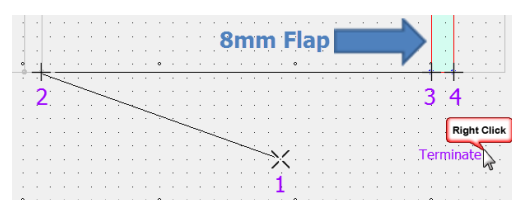
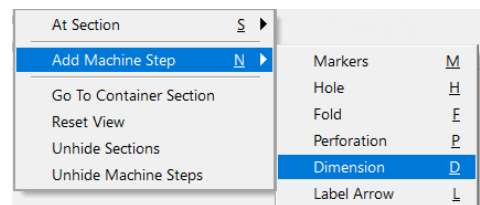

Annotations

You will see the resulting dimension line and the numerical measurement. (Shown here = 8)

As you can see the added dimension line is **143.7**, reflecting the red machine line of the flap, whereas the **Actual Panel Dimension** is **150**

We now will discuss how to change the **text size** to make dimension measurements smaller to fit.

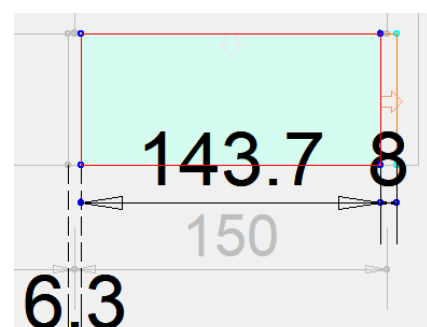

Step 8

Format Machine Step

To make the text smaller, change the **Text Size** from 4 to 2 by formatting the Machine Step

- right clicking on Machine Step, near the dimension arrow, as shown.
- from the context menu, select - At Machine Step **M** > Format Machine Step.
- this will open the Dimension Formatting dialog, shown.
- Use the Up/Down arrows to change Text Size, in this case from 4 to 2.

See [Tutorial 110 – Step 3](#) for more details

Note: If you want to save this as a **template** for future use, you can to [‘Add to User Library’](#)

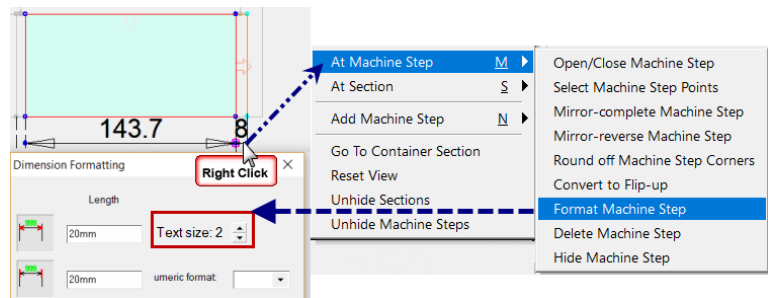

Step 9

Send to Flexi

The box will now appear as contours in flexi.

There are different colors, which represent different layers/cut operations.

- ❖ Green lines are fold lines.
- ❖ Red lines are cut lines.

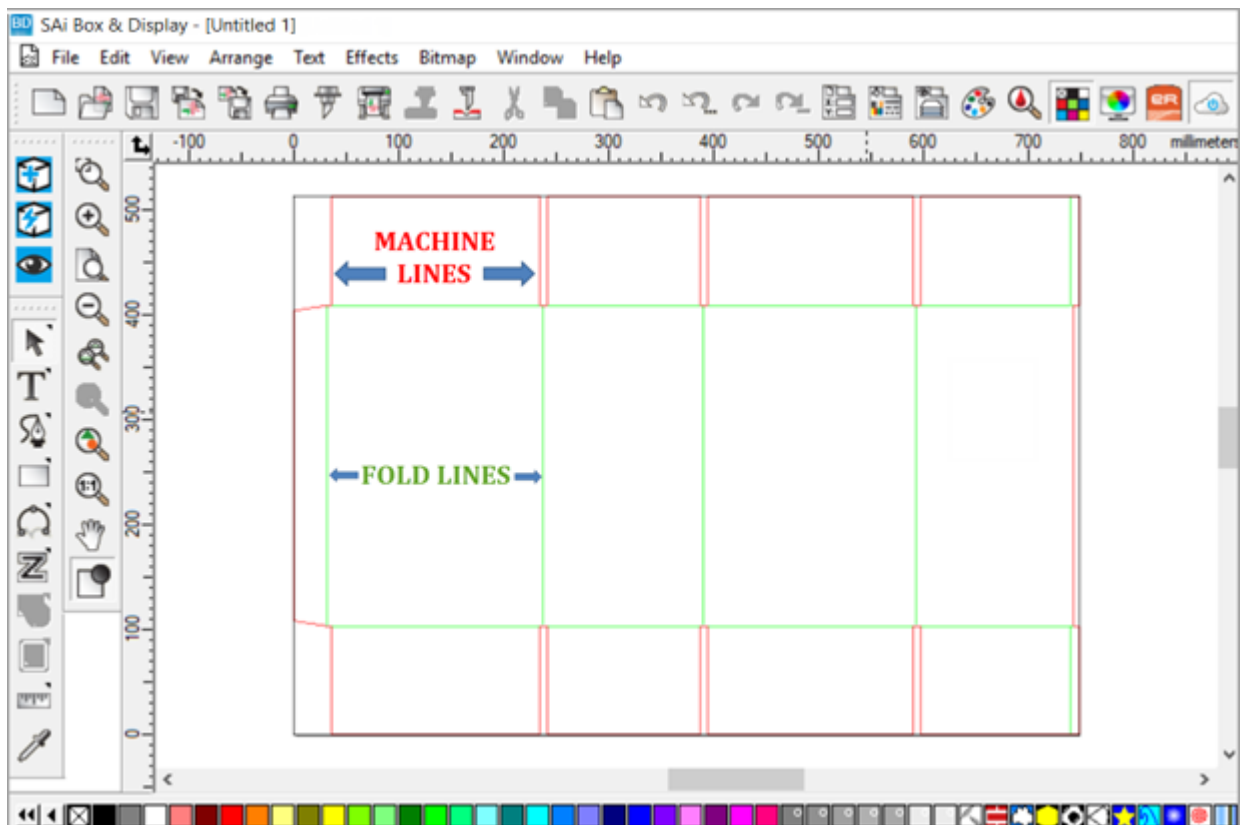

Template Tutorial 201 – Shelves / X017 Clinton FSU

In Box&Display there are many variations available and we will discuss the “X017 Clinton FSU” (FSU=Floor Standing Unit) to show you the ability to configure settings such as size, number of shelves etc., and some additional style options.

Tutorial Video  [X017 Clinton FSU](#)

Browse Standard Library: POINT OF SALE /Shelves / X017 Clinton FSU

Shown is a 2D preview and a photo of the box after we make changes discussed in this topic.

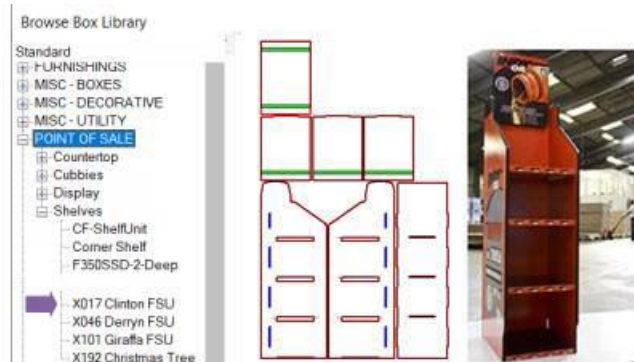

Unit Style

Input Edit lets you alter the shape of the top front corner of the side panel – image below squared.

DXF lets you use a DXF shape to define the shape of the side panel – difference shown below.

* A DXF file is a file format understood by many graphical packages and is generated to send to your machining software – refer to [Tutorial 204 DXF Cutouts](#).

As shown below all other options for Back, Shelf, Toekick settings etc are the same.

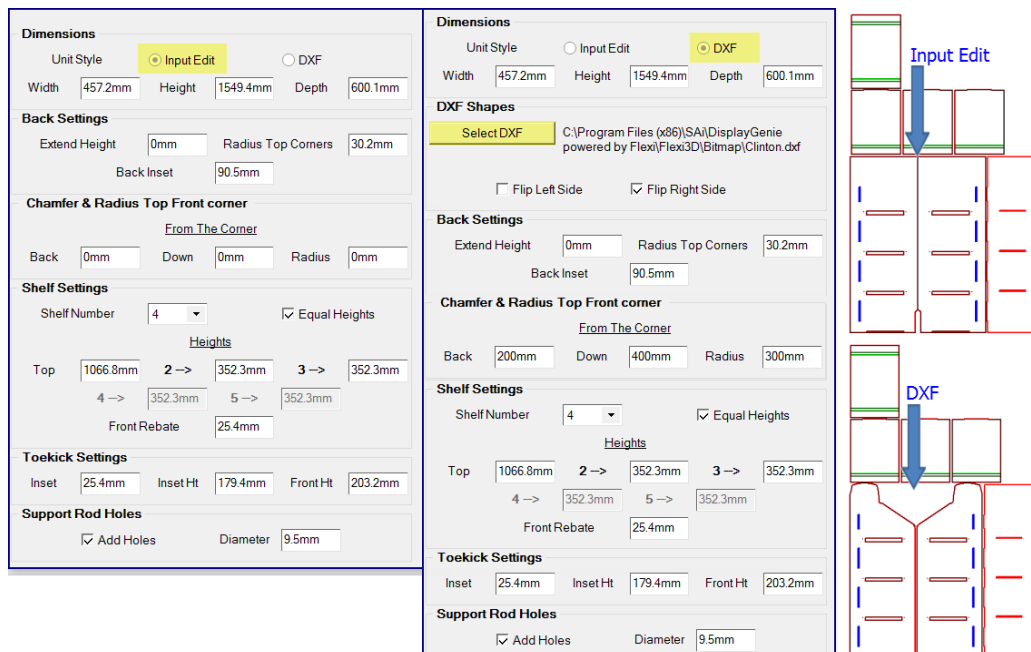

Back Settings

Extend Height – adjusts the height of the back e.g. changed from 0mm previous page to 160mm
 This becomes important when you want to display as per the photo of finished box on the previous page.

Radius Top Corners – increasing from 30mm to 160mm resulting in a more rounded corner - shown.

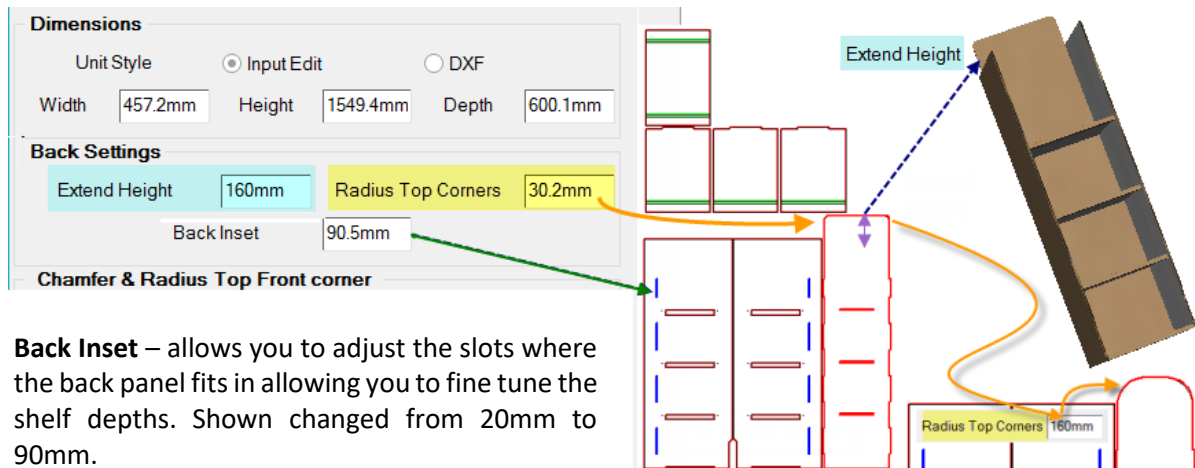

Back Inset – allows you to adjust the slots where the back panel fits in allowing you to fine tune the shelf depths. Shown changed from 20mm to 90mm.

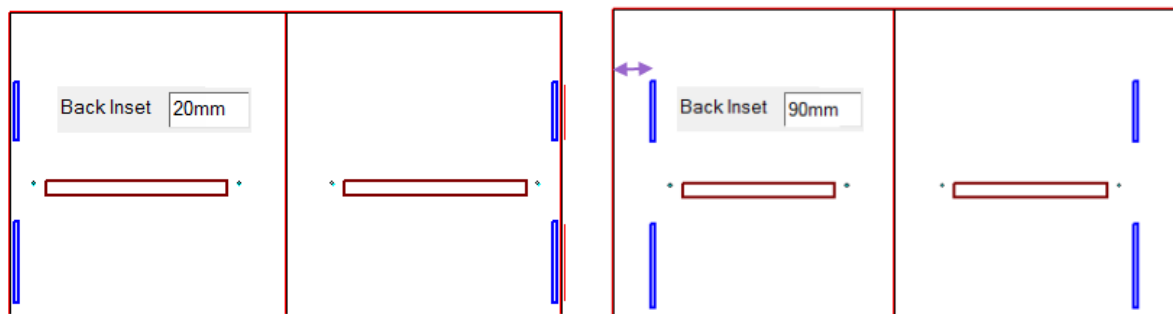

Chamfer & Radius Top Front corner

Used with Input Edit. Allows you to chamfer at different angles, and optionally radius the sharp corners.

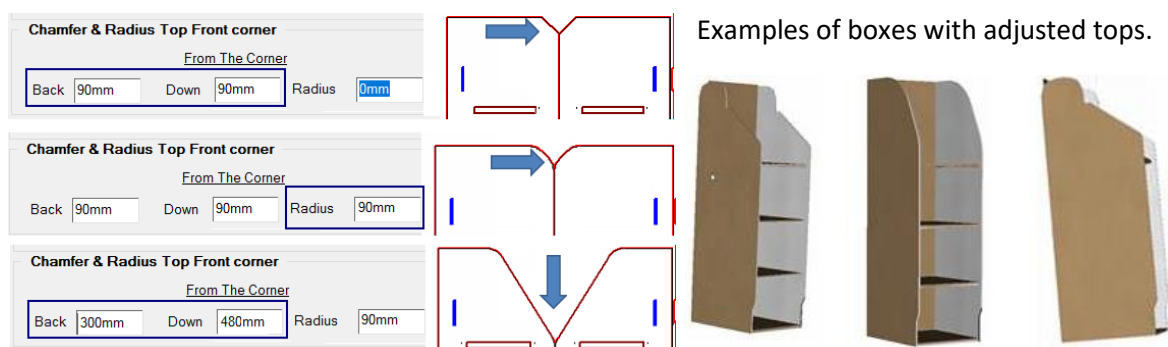

See [Sample Cutting Layouts](#) at the end of the tutorial.

Shelf Settings

Shelf Number - change the number of shelves from 2 to 6

Heights – either tick the ‘Equal Height’ checkbox or enter required individual shelf heights

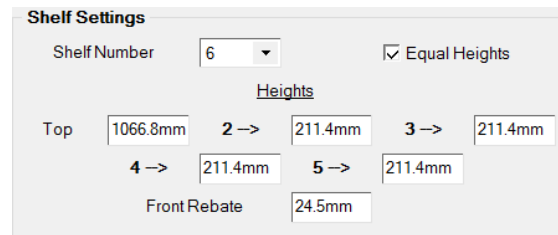

Toekick Settings

The diagram shows the effects of changing the toekick settings in 2D and the final result in 3D.

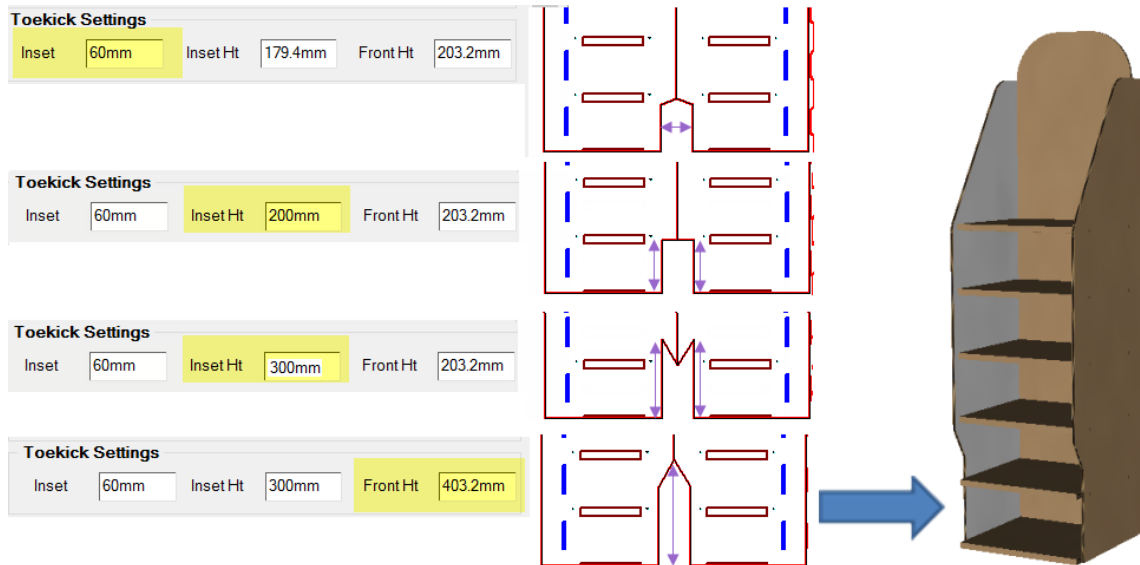

Support Rod Holes

Add Holes – tick to drill-holes which are used to thread rods through. Rods provide extra strength and support for the shelves.

Diameter – change as required to suit rods

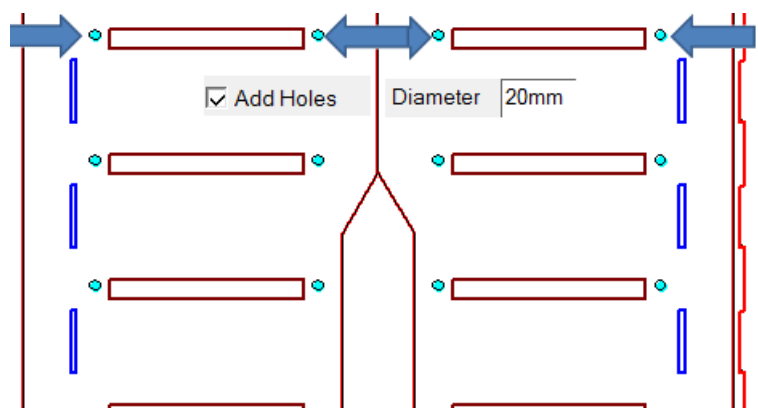
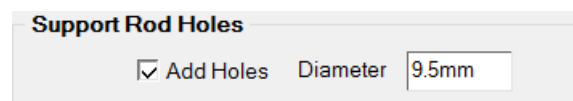

If your CNC machine is not able to drill these holes, then you can still print the little circles in the annotations layer of the design, and thus provide guide markings for manual drilling by the person assembling the POS.

Sample Cutting Layouts

The cutting layouts here show off some variations in the chamfer angles and the radiused corners for each side:

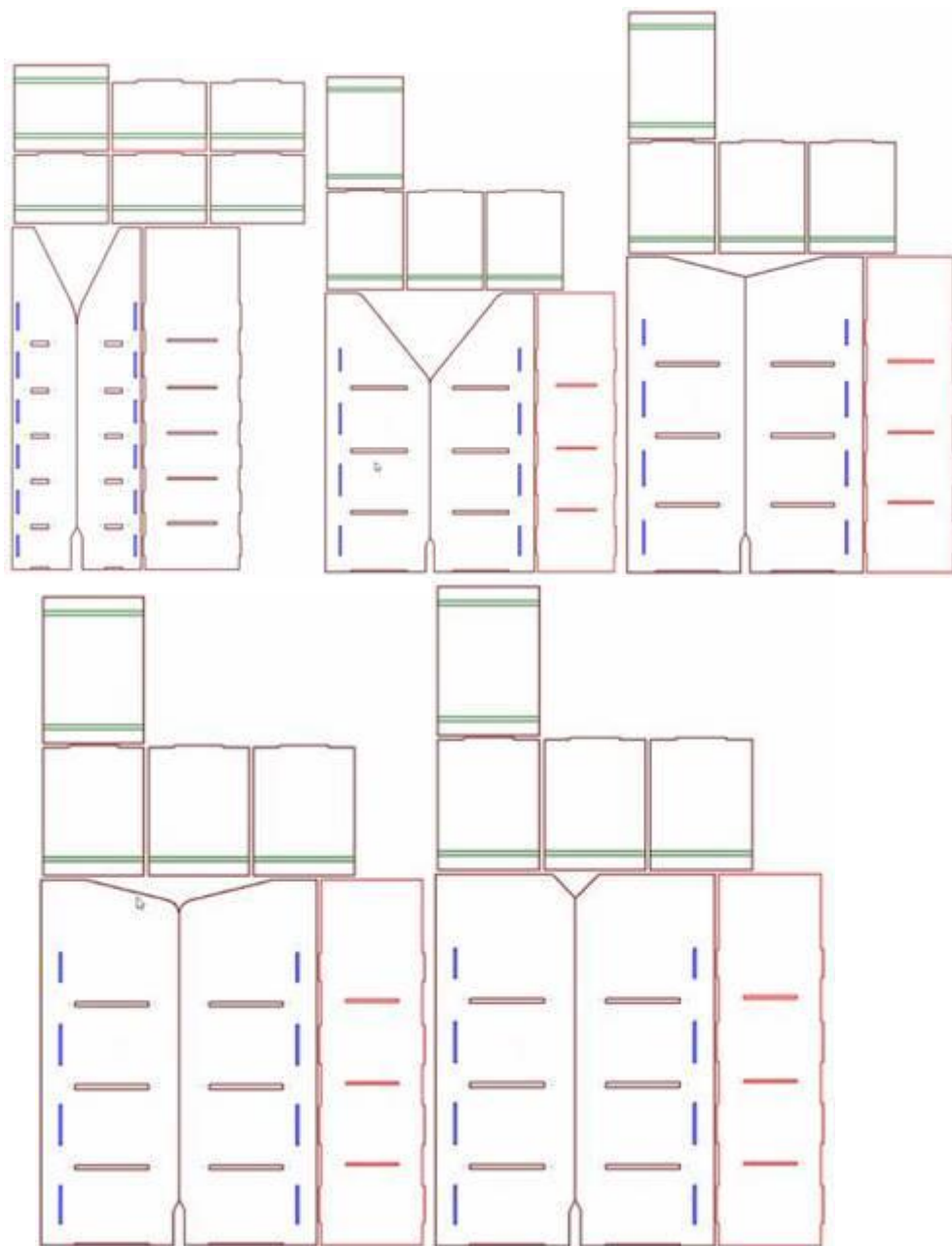

Template Tutorial 202 – Toolpath and Fold Lines

The diagram shows a template with a **fold line** (displayed in green) around the perimeter which acts as one strategy for cutting the foldline.

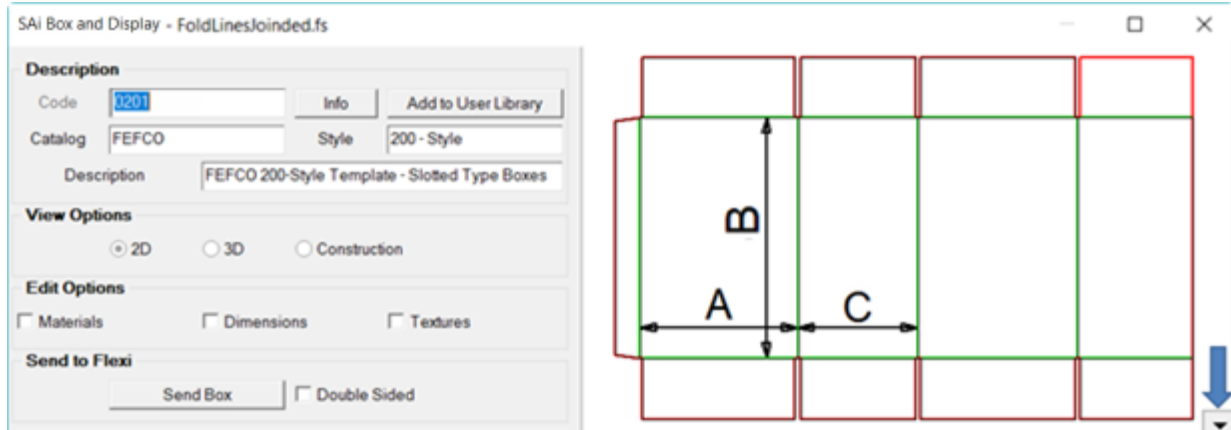

To demonstrate this better, we will filter the **machining layers** (displayed in red) so that we only see the fold line.

Machine Filters

- Open menu, bottom RHS of preview pane, indicated by blue arrow, image above.
- Untick Layers options, Cut and Info.
- Click OK (to Apply and Close) or Apply (remains open).

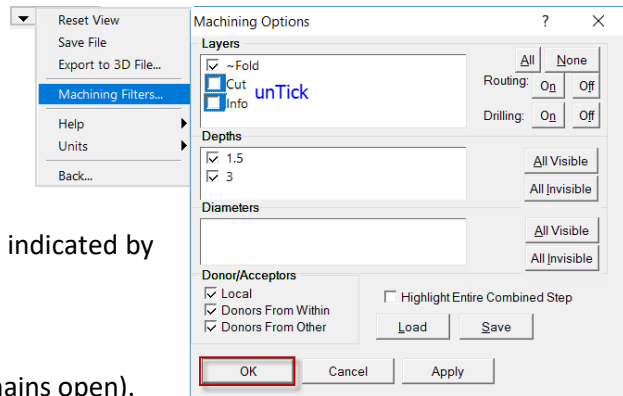

Note on Machining Options

All options can be viewed or not by turning On/Off using checkboxes or buttons on the right of dialog.

- **Fold Layer**– displayed in green
- **Cut Layer** - machine layers displayed in red
- **Info Layer** – annotations
- **Depths** relates to the cut depth i.e. in the above image, the Fold cut is 1.5mm and Machine layer Cut is 3mm which in this case is the depth of the material.
- **Diameter** relates to the drill holes if applicable.

The result is the following image, which clearly shows a continuous foldline around the perimeter and three separate internal fold lines i.e. not joined to perimeter fold line.

This allows for efficient machining, as explained on the next page.

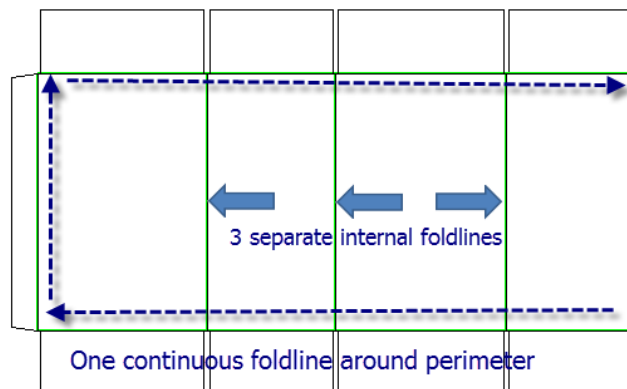

Fold Allowance

To begin, select (tick) Edit Option ‘**Dimensions**’ and scroll down to **Fold Allowance** settings

Slot Width can be either entered manually i.e. type in 20mm or selected from the dropdown menu.

The image below shows Panel 2 with a Top Recess of 20mm and a Slot Width of 20mm to show that the perimeter foldline is continuous, in a zig zag pattern for smooth fold/cut.

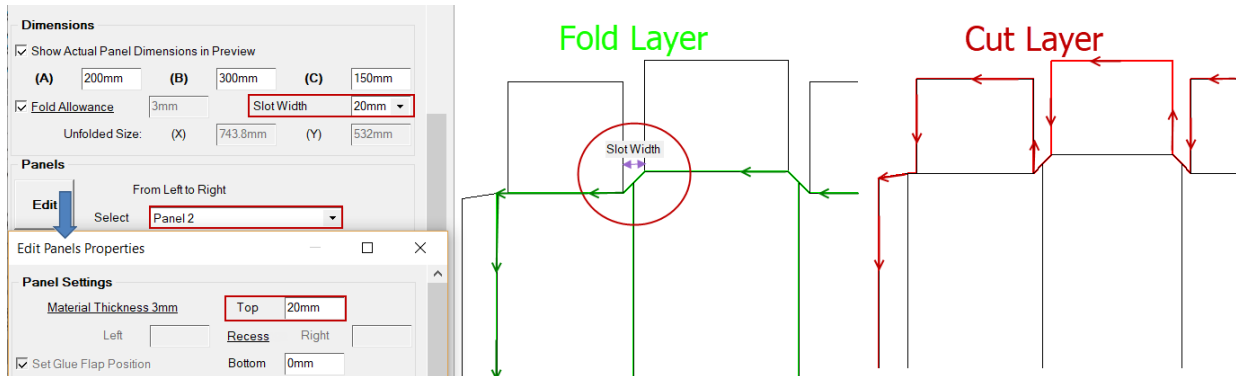

Material Thickness and Panel Recess

Now we will stagger the panels up and down, so that they can fold in a certain order and the thicker material can have a recess.

There are two ways of doing this. (1) One way was discussed in **Chapter 3** under the topic **Panels**, where you select required panels, individually, and then click on the **Edit** button to open the Edit Panels Properties dialog to change.

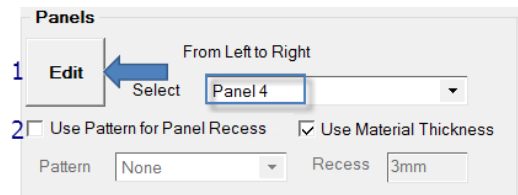

(2) The second way is to ‘**Use a Pattern**’ adjust panel heights, and the ‘**Use Material Thickness**’ to recess by either using the default Material Recess, which in the diagram states 3mm, or define a different measurement. We will now discuss this further.

Pattern for Panel Recess

The default Panel to use for a Pattern is set to ‘None’. To change this, tick the box to ‘Use...’ and from the drop down make a selection of Panels to use.

In this example, we will select ‘**Panels 1 & 3**’ which will **apply** the **Material Recess** (see above ‘Use Material Thickness’ is ticked) which is **3mm** to these panels.

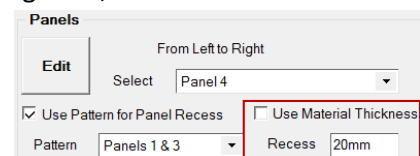

Result is that the Panels selected will be staggered, as shown below left.

To change the **Recess**, untick the ‘**Uses Material Thickness**’ and **type in** required recess e.g. **20mm, shown below right**. Remember, even if with the changes, the perimeter (green) toolpath will remain continuous.

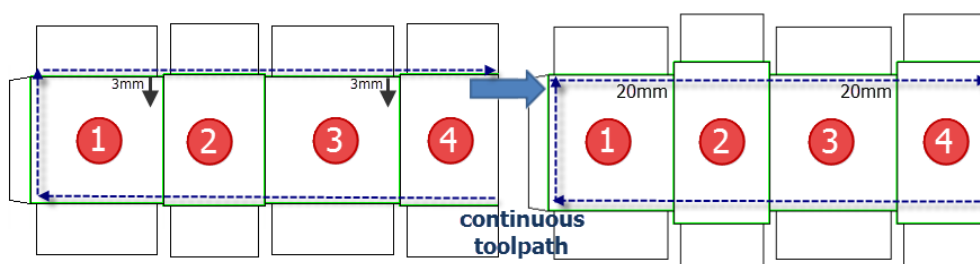

Template Tutorial 203 – Sloped Shelf Displays

In this tutorial, we will be discussing the features of the Sloped Shelf Display (F SSD).

Tutorial Video  [Floor Sloped Shelf Displays](#)

From the Standard Library, select **POINT OF SALE/Shelves/F350SSD-6-Deep**, as shown.

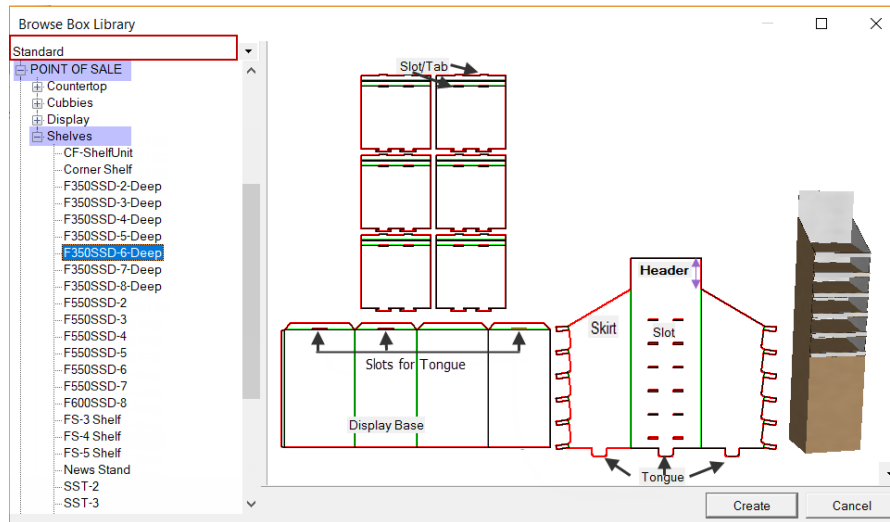

Turn on 'Dimensions' and we will discuss the parameters. The above diagram has been labelled to aid discussion.

Display & Product Parameters

Display Base Height – diagram below shows the Height changed from **762mm** to **200mm**. Compare **2D** with **Construction** view which has dimensions added below.

Slot/Tab Width (60.3mm) and **Gap** (100mm) as shown.

The **Tongue**, labelled in above diagram, are on the Top unit and these slip into the Slots of the Display Base.

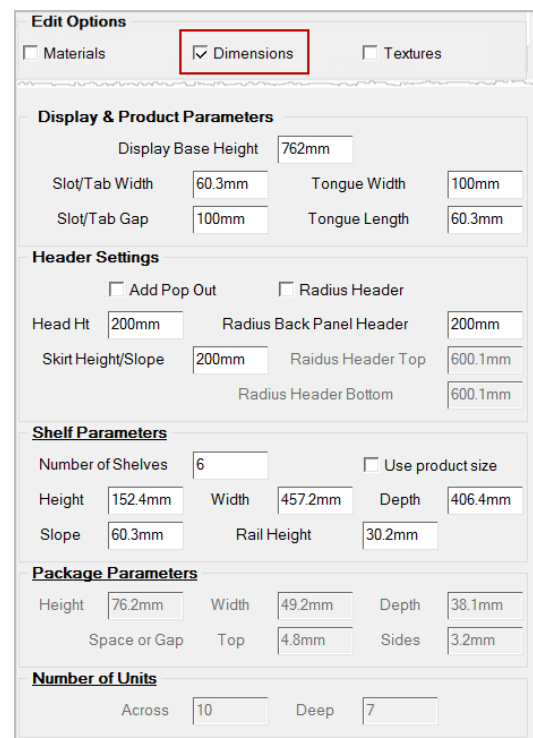
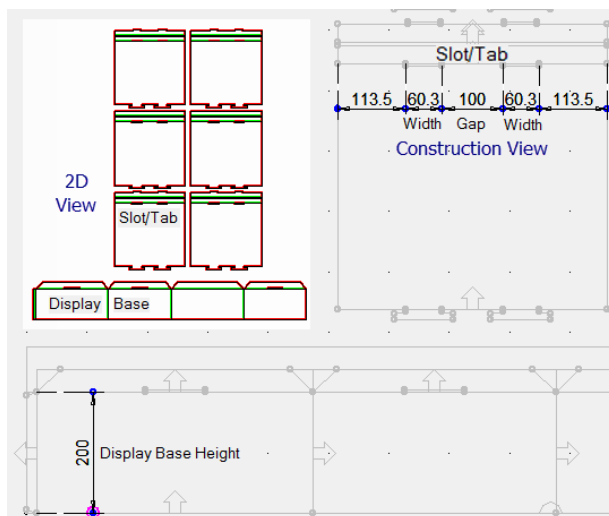

Header and Skirt Heights

The effects of changing the **Header** and **Skirt** heights, from 200mm to **0mm**, can be seen in *fig1* and *fig2*. *Fig3* shows the Header height changed back to 200mm.

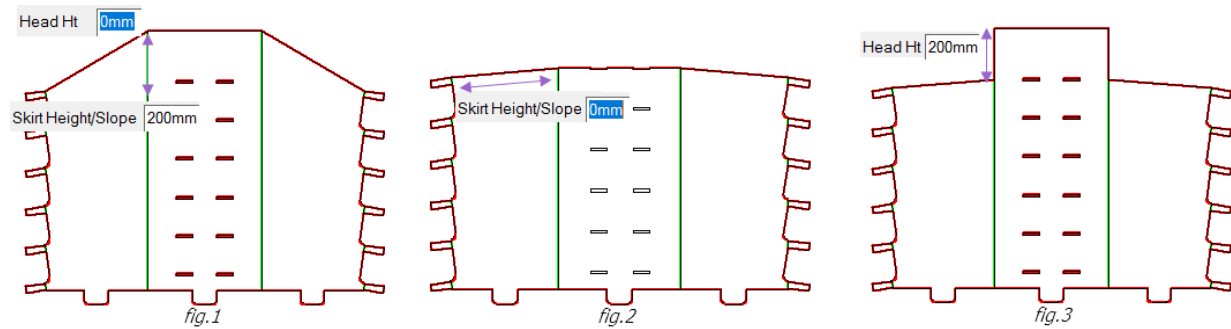

Header Radius

Turn on/tick 'Radius Header'.

In *fig.4* the **Header Height** is 200mm and the radius of the **Back Panel Header** is 200mm. This just applies the radius to the corners so, since the **Width is 457.2mm**, you can see a *flat section* in the middle. This happens as the height of the header is *below* half the width of the unit.

- Try entering **500mm** in the **Back Panel Header**. You will note that the entered radius will automatically change to **200mm**, as the software determines that the radius entered is larger than half the width.

In *fig.5* the **Header Height** has been changed to **400mm**.

- Enter **500mm** again in the **Back Panel Header**. The entered radius will automatically change to exactly $\frac{1}{2}$ the width which is **228.6mm** and note that there is no flat section.

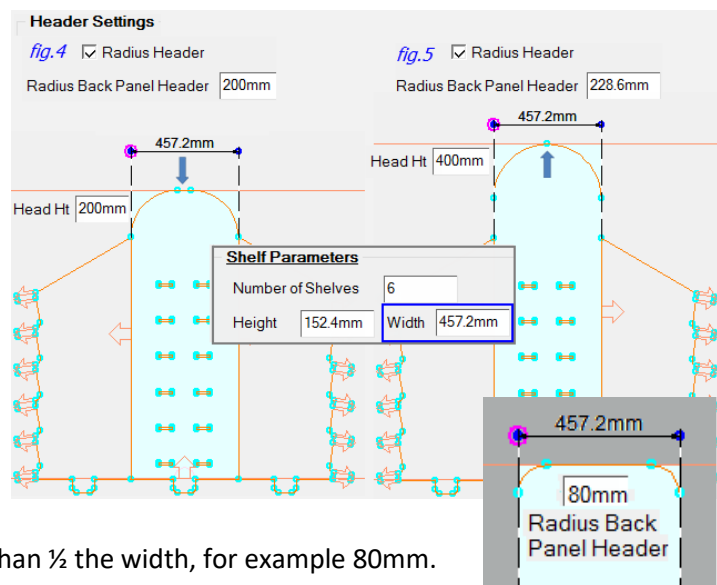

Of course, you can select a radius smaller than $\frac{1}{2}$ the width, for example 80mm.

Header Pop Out

You can add a Pop Out, as shown here in Construction View.

- Change **Head Ht** to 200mm
- Untick **Radius Header**
- Tick **Add Pop Out**

In 3D View you can see that the header has popped out to the front, so that you can illustrate. You can also radius the header as shown.

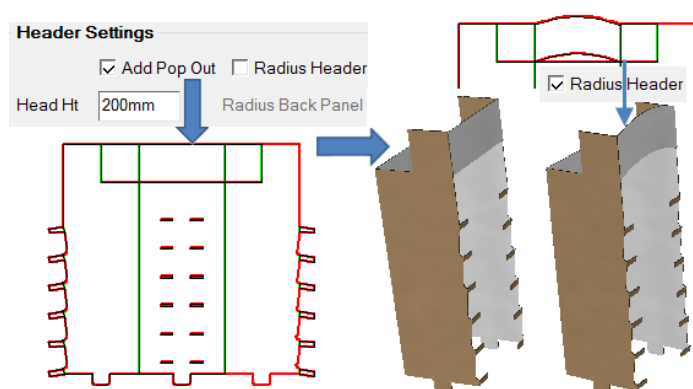

Header Pop Out Radius

The following shows how the **Radius Header Top** can be resized independent to the **Bottom**

- In *fig.1* the Radius Header **Top and Bottom** are **both 600.1mm**
- In *fig.2* the Radius Header **Top** has been changed to **300.1mm**
- In *fig.3* the **Width** has been changed to **600mm**

Note that if you try and change the Radius Header **Top** to **200mm**, you will see that the software will *automatically convert it back to the maximum* of 300mm.

The image shows a software interface with 'Header Settings' and 'Shelf Parameters' sections. The 'Header Settings' section includes checkboxes for 'Add Pop Out' and 'Radius Header', and input fields for 'Head Ht' (200mm), 'Radius Back Panel Header' (200mm), 'Skirt Height/Slope' (200mm), 'Radius Header Top' (600.1mm), and 'Radius Header Bottom' (600.1mm). The 'Shelf Parameters' section includes 'Number of Shelves' (6), 'Height' (152.4mm), 'Width' (457.2mm), and 'Depth' (406.4mm). To the right, three diagrams labeled 'fig.1', 'fig.2', and 'fig.3' illustrate the header radius and width changes. 'fig.1' shows a header with a 600.1mm radius at both top and bottom. 'fig.2' shows the top radius changed to 300.1mm. 'fig.3' shows the width changed to 600mm. Blue arrows point from the software settings to the corresponding diagrams.

Shelf Parameters

The Shelf Parameters allow you to set the 'Number of Shelves', 'Height', 'Width' and 'Depth'.

Shelf Height – change to 200mm

Shelf Depth – the shelf is on a slope, so the sides of box are not as deep as the sloped shelves. Change the Depth to 400mm.

Slope – is the slope of the shelves from back to front.

Rail Height – is the height of the rail in front. Which can be increased to stop packages sliding off.

Image on left shows the box in 3D, flat i.e. **Folded 0%**.

Image on right has been **Folded 100%**, which is necessary before assembly, and rotated for a better view.

The image shows a 'Shelf Parameters' settings window with the following values: Number of Shelves: 6, Height: 200mm, Width: 600mm, Depth: 400mm, Slope: 60.3mm, Rail Height: 30.2mm. There is a checkbox for 'Use product size' which is unchecked.

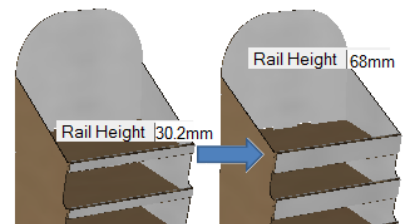

The image shows two screenshots of the 'Folding Control' interface. The left screenshot shows the 'Fold %' slider at 0, with a 'Play' button and '8 stage(s)' indicator. Below it is a 3D model of the box in its flat state. The right screenshot shows the 'Fold %' slider at 100, with a 'Play' button and 'Assemble Unit' button. Below it is a 3D model of the box in its folded and rotated state, labeled 'Folded and Rotated'.

Assemble Unit

Use the 'Assemble Unit' button to assemble. Note that the Unit must be completely folded i.e. 100% before assembly.

The result, shown *fig.1*, can also be amended while you are in **3D View**. The preview will adjust dynamically and parametrically.

For example, turn off/untick Pop Out as shown in *fig.2*.

NB: The description on the button will change alternatively from Assemble to Disassemble and visa versa.

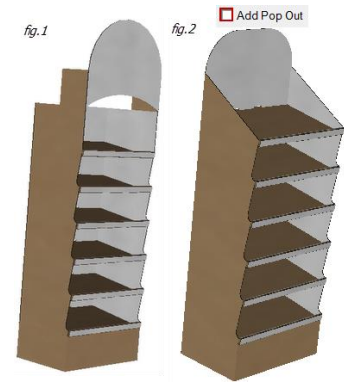

Package Parameters

To see how we use these, go back to **2D view**.

These parameters are greyed out until you turn on/tick 'Use product size'

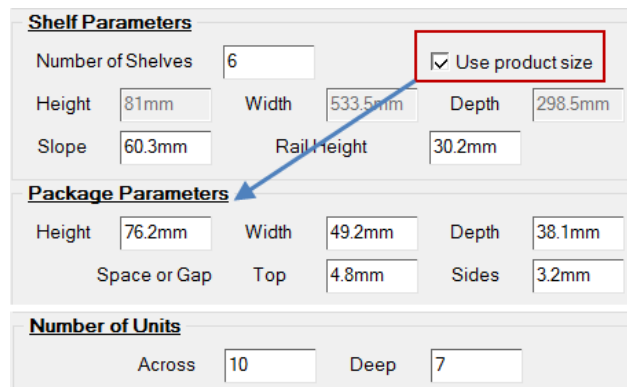

These setting allow you to adjust the shelves based on the *size of the packages* that will be displayed.

Here we can see that our packages are 76mm high, 49mm wide and 38mm deep.

Also, the **Number of Units** show that each shelf has 10 packages across with a depth of 7 i.e. 70 packages can be stored on each shelf.

Space or Gap

- change the **Top gap** from 4.8mm to **80mm**, which will allow room for you to get the packages out from the shelf.
- The Sides gap ensures that the packages are not squashed in too tight.

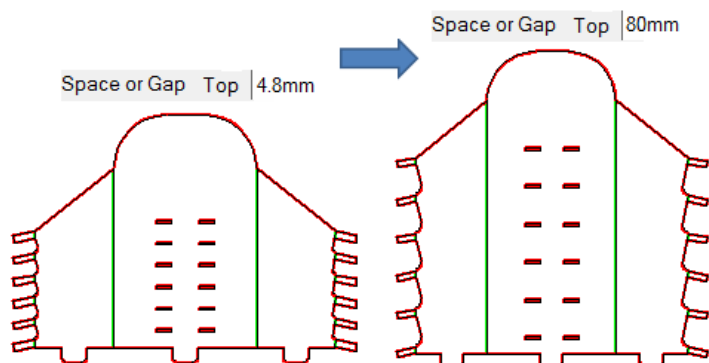

Template Tutorial 204 - DXF Cutouts

The following is based on a couple of videos, showing the use of DXF cutouts in Box&Display...

See also [Tutorial 208 Box Inserts](#) which show another use for DXF cutouts.

Tutorial Video 1 [DxfCutOuts1.mp4](#)

The first video shows the DxfCutOut unit in the POS library, set up with a “swan” dxf...

Here we have a “display basket” where the two sides are in the shape of a swan →



Tutorial Video 2 [DxfCutOuts2.mp4](#)

In the second video, we take a piece of clipart from the internet for a Rocking Horse which we will bring into Flexi and select Bitmap|Vectorize|Autotrace to get a suitable RockingHorse.dxf.

(1) Swan Basket Display

From the Standard Library, select **MISC – DECORATIVE / Animal / DXFCutOutDisplay**, as shown.

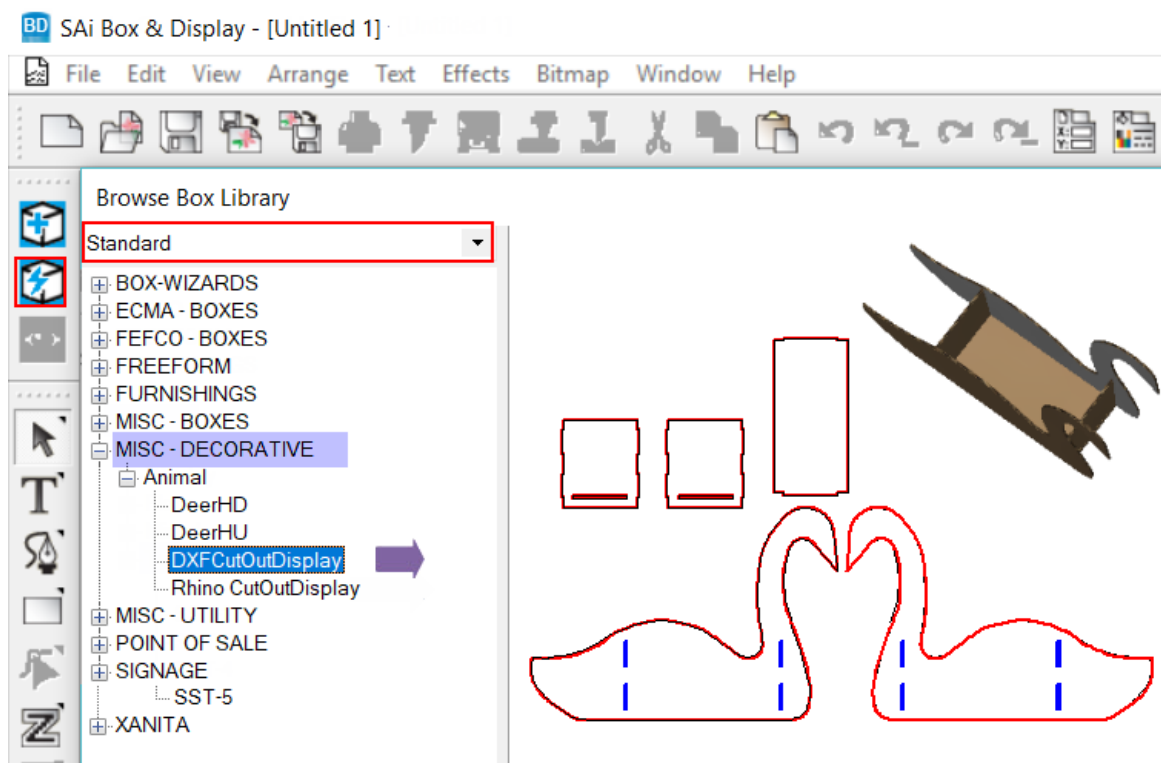

This is a standard DXF shape imported into Box&Display and allows you to adjust to suit. As shown in 3D, this DXF creates a basket effect in which you can place your products for display.

Dimensions

The image shows the preview pane in Construction View, so as to explain the Dimensions.

Width – is the width of the bottom (149.2mm) plus the width of the material on both sides
i.e. $(4.8\text{mm} \times 2) + 149.2\text{mm} = 158.8\text{mm}$

Height – is from top to bottom height

Depth – is from front of swan back, as shown below, dark blue dashed line.

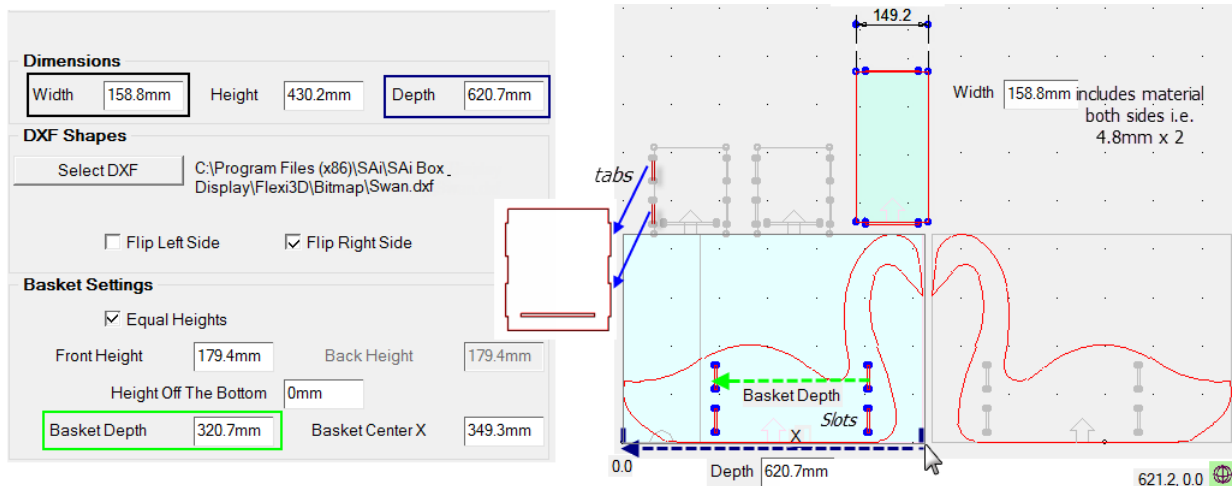

Basket Settings

The panels that hold the Front and Back section of your basket together can be set to 'Equal Heights' by turning on/ticking the checkbox as shown above. Turn off/untick 'Equal Heights' to set independent heights. The image on the right shows the 'Front Height' remains at 179.4mm but the 'Back Height' has been reset to 90mm. The number of tabs on the Back panel reduces to one but the number of slots remain the same. However, since a skin is left by over the slot, see discussion below, this will not matter.

Height Off The Bottom – relates to the height of the slot from the bottom. To illustrate the setting has been changed to 40mm in the image on right.

Basket Depth – is the distance from the *outside* edge of the slots, shown green dash line.

Basket Center X – is the wherever you want the center of the part to be, which is the center of the Basket Depth. Using the global coordinates, we can see that the distance from the 0.0 coordinate to the end of the Active Section, denoted by the cursor, is 621.2 and if you move the cursor along, 349.3 will be approximately where the X is shown. See [Tutorial 106 - Notes on Coordinates](#)

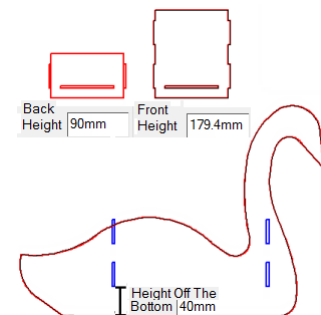
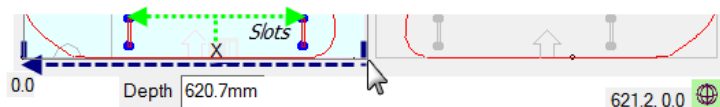

Slots

The slots are created using a machine step called a 'kiss cut'. This means that your tool will cut all the way thru *except* for the last millimetre and therefore it saves the skin on the outside. The tabs on the joining sections, shown above, insert into these slots. The two joining sections also have slots, in which the tabs of the bottom section are inserted to hold the basket together. You will need to use adhesive (glue) or hold together in some other manner.

DXF Shapes and Flip

Select DXF – use this button to browse for dxf files saved on your computer – See **(2) Rocking Horse Display**.

Flip – turn on/off to horizontally flip image. On the image right, we have turned off the Right Side and the “swans” are not facing the same direction.

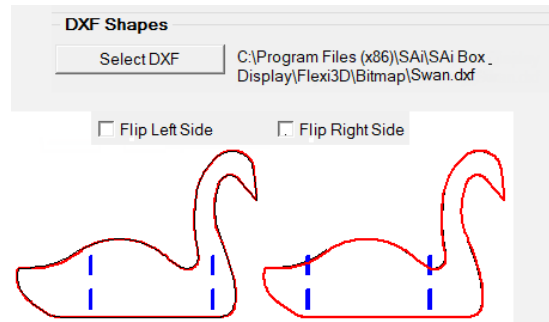

(2) Rocking Horse Display

In the second lesson/video, we take a piece of clipart from the internet for a Rocking Horse which we will bring into Flexi and create a dxf.

Tutorial Video 2  [DxfCutOuts2.mp4](#)

ClipArt Imported to Flexi

- You can get this free clipart at <http://www.allthingsclipart.com/03/rocking.horse.clipart.htm>
To save clipart to your hard drive, right click on a graphic, and then choose "save as" and select a location on your computer.
- Then **File > Import** into Flexi.

To get a suitable RockingHorse.dxf we need to

- select **Bitmap > Vectorize > Autotrace**, shown below left.
- Click on top left hand side of images and click and drag to select, shown below right.

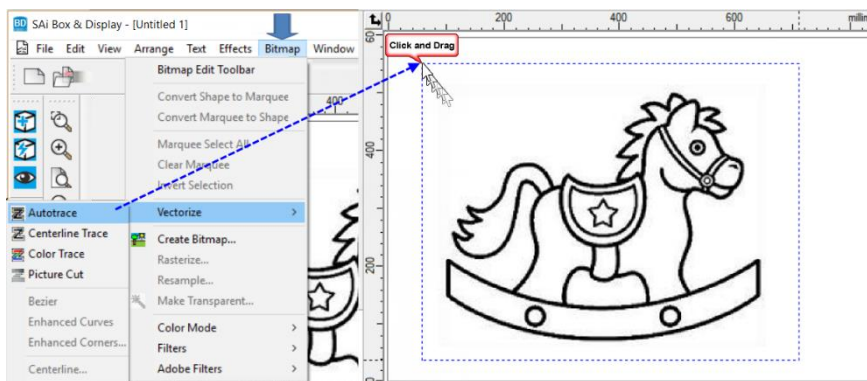

You will see the resulting shape, after **dragging the initial image away**, as shown below.



Use **Zoom Tools** to select / increase / decrease image.

Box&Display allows you to have dxf's with folds or cutouts in them. However, you need to manage the cutouts so that the final cut shape will not have pieces falling out.

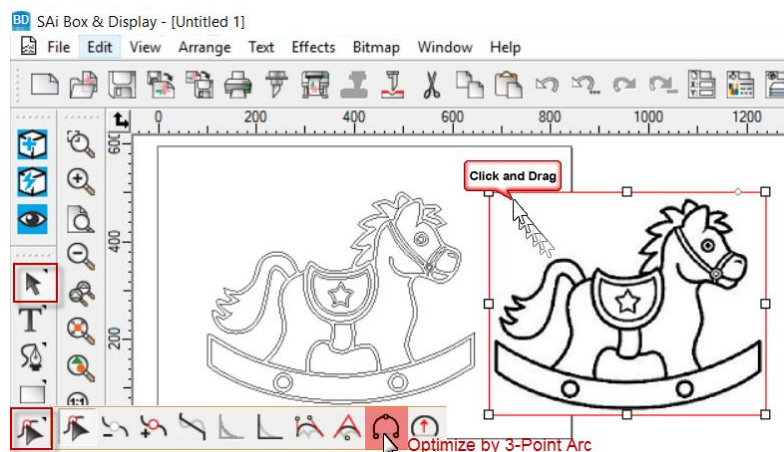

To do this we will use 'Optimize by 3-Point Arc' from the flyout as shown.

Customize ClipArt for Cutout

As stated, we need to manage the cutouts so that the final cut shape will not have pieces falling out.

- Using the  'Optimize by 3-Point Arc' tool, to select/delete unsuitable parts of image.

Note: If you cannot find it, ensure that the **Main** toolbar is turned out from **View > Toolbars**, as shown.

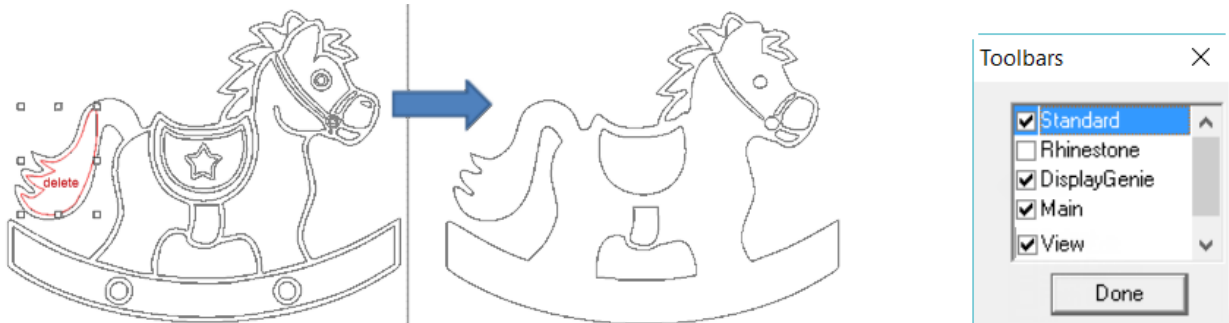

- Now save as a dxf by simply selecting **File > Export**, shown below left, and select a location on your computer.
- Then go back to your swan by selecting the applicable **Window**, as shown below right.



- then using the 'Select DXF' button, browse to replace the swan.dxf with the **RockingHorse.dxf**

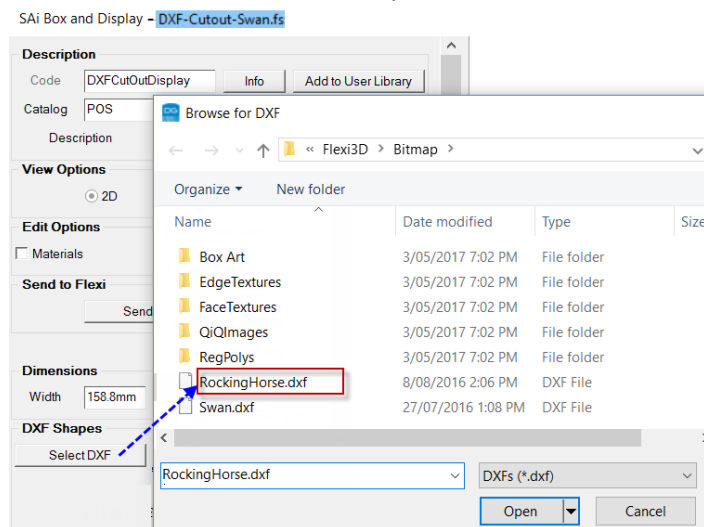

Adjust the position of the fixing slots, which you can do visually in Box&Display

- change position of slots ...
 - Height Off the Bottom 20mm
 - Basket Depth 220mm
 - Basket Center 315mm

You are now ready to cut the final shape and assemble, as shown in 3D.

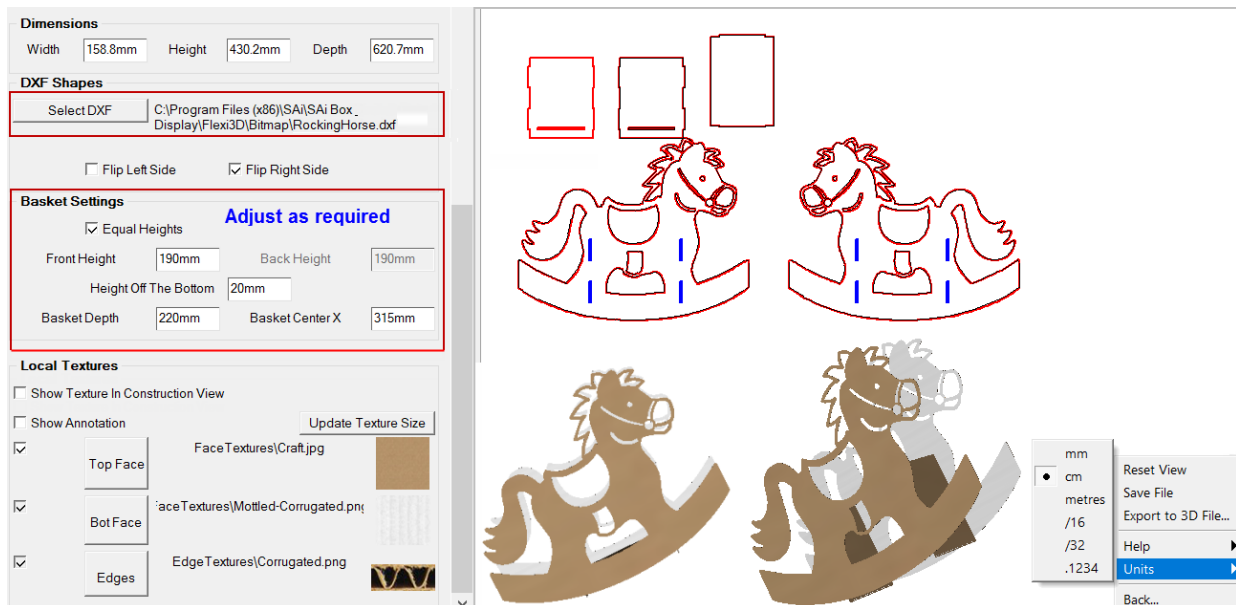

Template Tutorial 205 – Countertop Box and Flip Up

In this tutorial we will create a flip up in a Point of Sale [POS*] display box.

* where a product is passed from the seller to the customer.

Tutorial Video  [Countertop C-FL-300-2 SuperHero Flip Up](#)

When you Browse the Standard Library, you can select **POINT OF SALE / Countertop /** and either the...

- **C-FL-300** template with a cutout, flip up *curved* shape.
- **C-FL-300-2** which has a *square* top, to make your own Flip Up shape

NB: The following Tutorial is similar to [Tutorial 111 – FreeForm Flip Up](#)

Step 1

Import Clipart

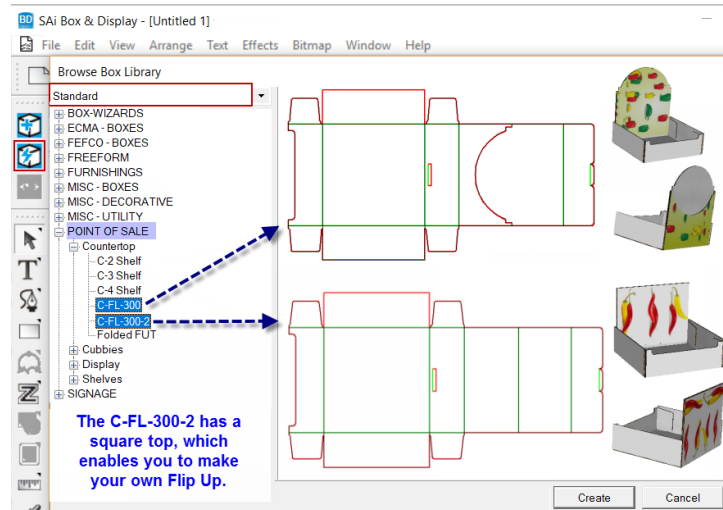

- select from the **POINT OF SALE / Countertop / C-FL-300-2** template
- **File > Import** a 'Superman' clipart and place on pop up area, as shown below right.
-  View in SAI Box Display, **Construction** View with **Textures** Edit Option turned on.
- ensure that **'Show Texture in Construction View'** is also turned on, so that you can see 'Superman' image, as shown.

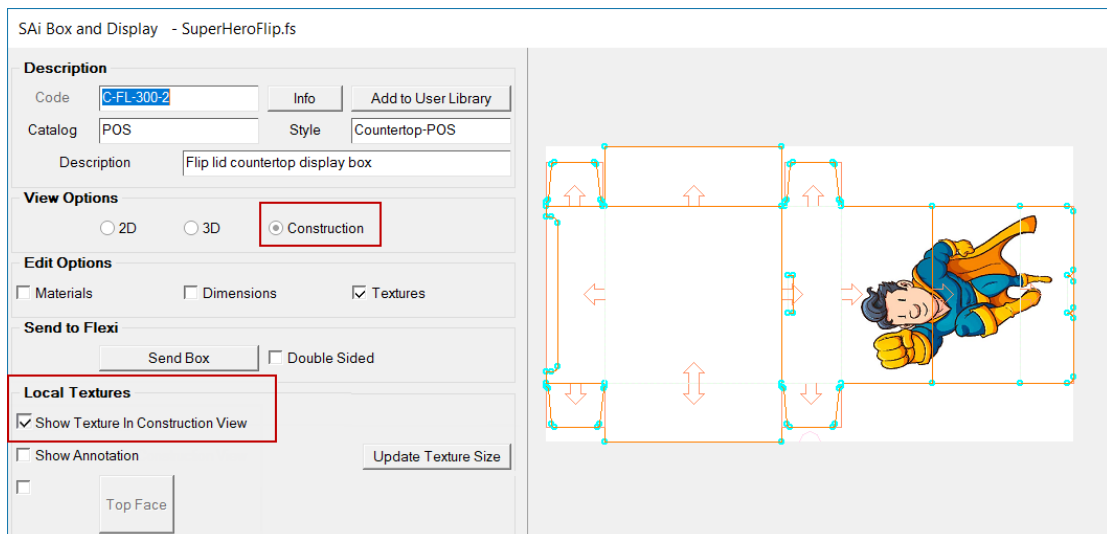



Step 2

Perforation Machine Step

Flip ups are made with a perforation machine step.

Remember that perforations can only be done *outside the current Active Section*, as shown.

- Select the section shown in the image to make **Active**.
- Since this is an Imported Section, click on the lock  and unlock 
- See [Chapter 4 Lock/Unlock](#) for more details.
- Right click and from the context menu, select Add Machine Step **N** > **Perforation**

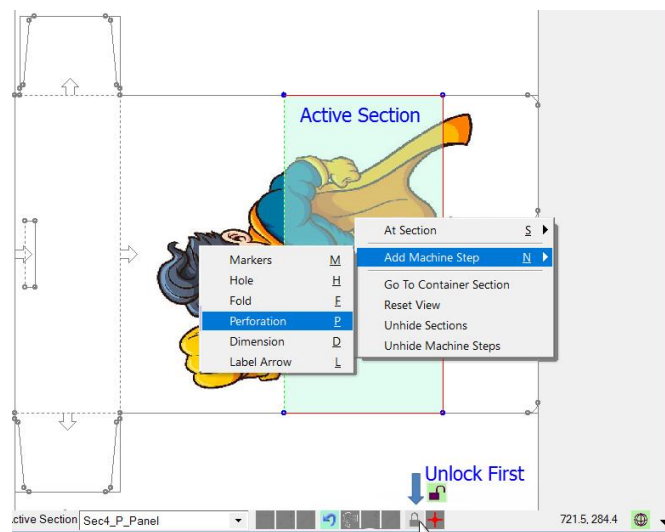

NB: This machine step has to have its two ends on the **Fold Line**, shown on the image below.

Tip: Zoom in for better view

- **Start** perforation cut out, as shown.
- The cursor changes to , left **click at the 2nd point** and BD will automatically close the selection with a straight line.
- Continue as shown for **all points** for perforation, stopping at Fold Line as shown.
- **Terminate** when completed at top fold line with **right click**.

NB: You can **Drag Point G** and/or curve later, if any of the points don't exactly end up in the required position, as discussed next.

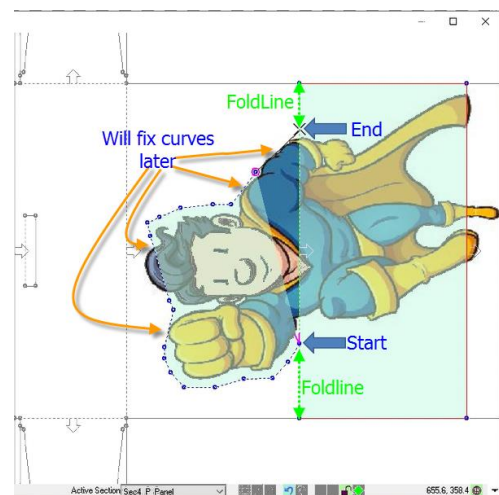

Step 3

Curve Line

When we added the perforation in the last step, there were a number of lines that needed adjustment by changing the lines into curves to properly fit around the clipart image. To do this...

- Left click on the line you want to adjust, to select.
- Right click to get context menu
- Select **At Line** > **Curve Line** as shown below

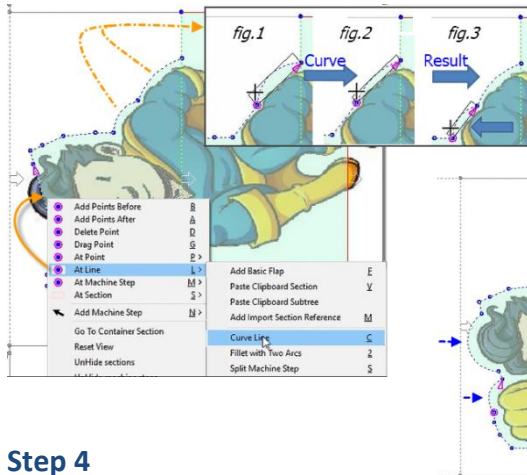

- The cursor changes to a + and you will be able to drag the line out/in as shown in *fig.1* / *fig.2* until you get the result you require in *fig.3*.
- Repeat for all lines that need adjustment.

The result should allow for a clean cutout.

Step 4

Convert to Flip Up

- Now right click on a point of the perforation
- from the context menu, select **At Machine Step M** > **Convert to Flip-up**

Note perforated lines change to **red** lines i.e. machine step.

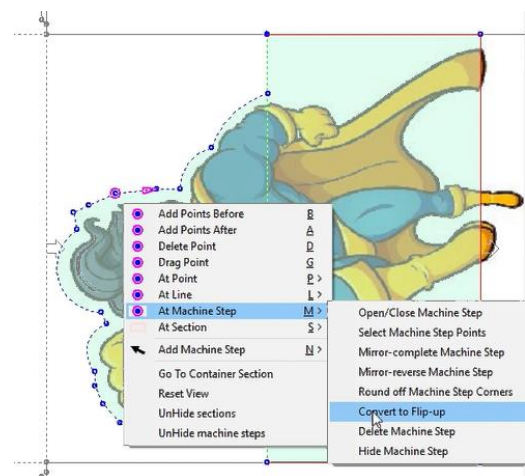

Step 5

Fold

Change the View Option to 3D and use the Folding Control to fold. You will see something like the following images.

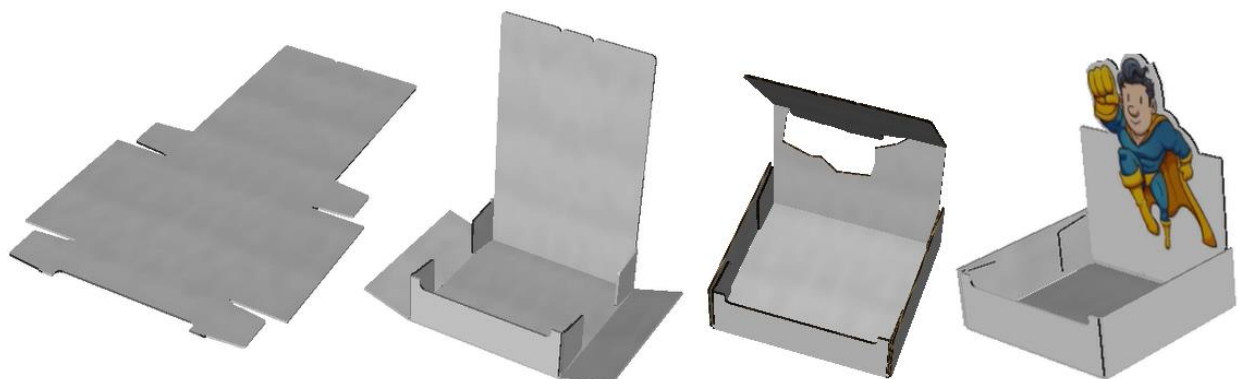

Template Tutorial 206 – Furniture Modern Shelf

Browse the Standard Library and select **FURNISHING / Furniture / Modern Shelf Unit** template

[Tutorial Video](#)  [Modern Shelf](#)

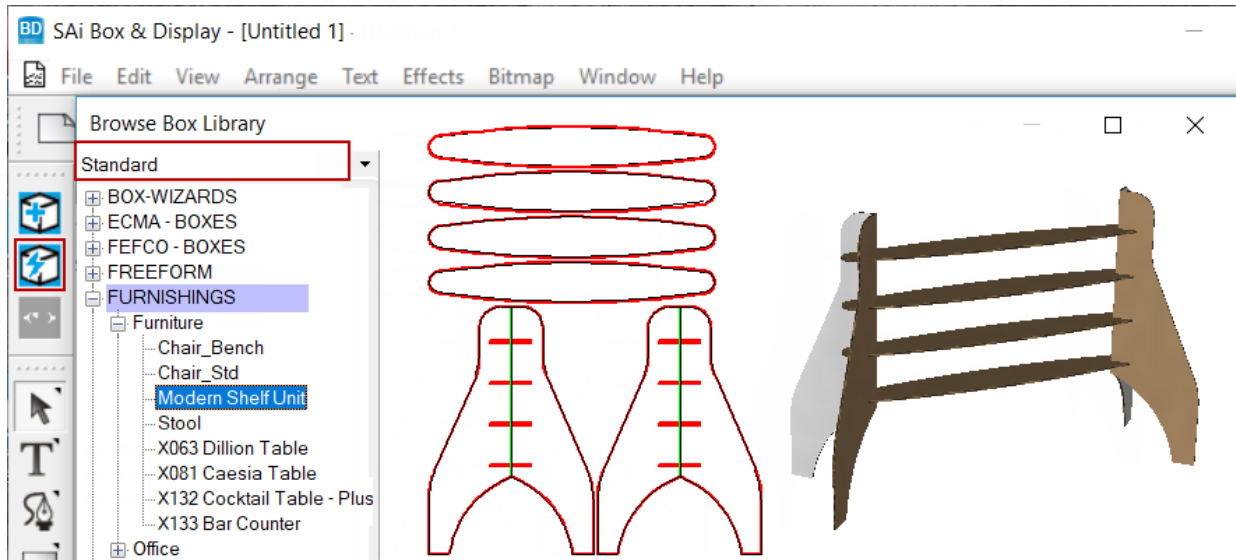

Shelf Settings: 2 to 4 shelves can be selected from the dropdown menu. Field boxes allow the manual entering of Width, Depth, Space between shelves and the End Extn (refer diagram on the next page).

Leg Settings: The following diagram show the effects of leg settings.

Center & End Points – see Dimensions (middle of diagram), compared to settings.

Blend Radius – see Points effected by Top, Top-Mid and Middle (on far right of diagram). Compare **Middle Inset**, shown below as **0mm**, with image on the next page where the Middle Inset is **200m**.

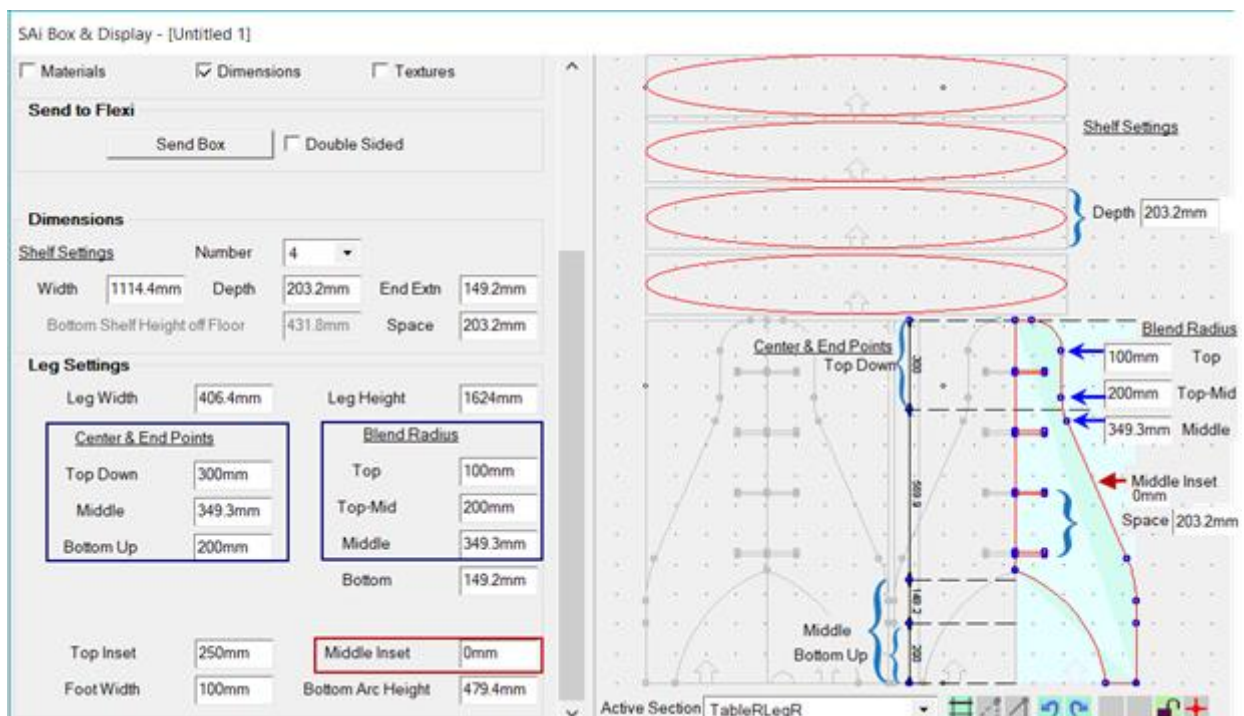

Blend Radius: Compare **Middle Inset**, shown below as **200mm**, with image on the previous page where the Middle Inset is **0m**

The Bottom Arc Height is shown here as 479.4 – change this manually by typing in a smaller number such as 79.4mm, which will result in a straighter line.

Width: Leg Width and Foot Width dimensions* are shown.

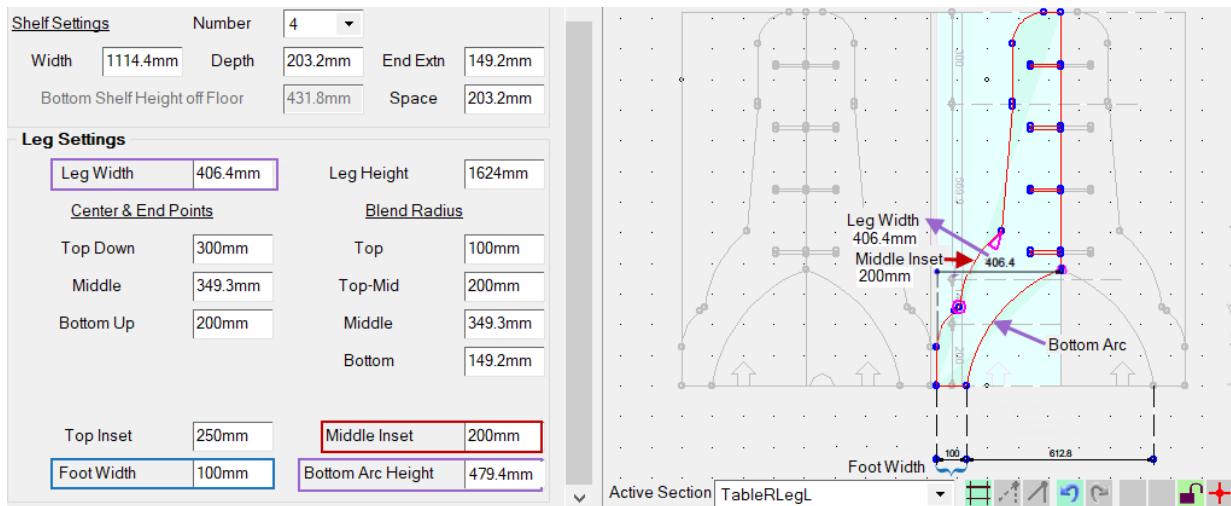

* For more details on how to Dimension in Construction View – refer end of Chapter 1.

Top Inset – the results of changing the dimension can be seen below left.

Shelf End Extn - the results of changing the dimension can be seen below right.

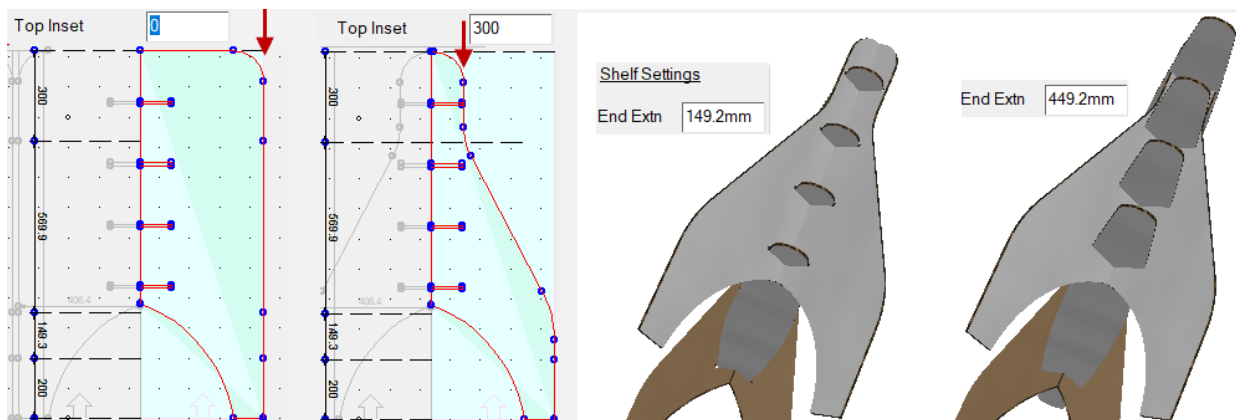

Template Tutorial 207 – Furniture & Stands

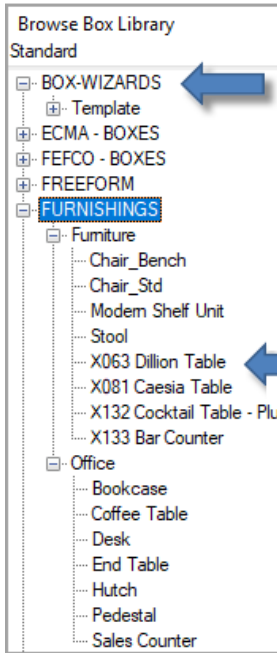

Sai Box&Display can be used to create virtually any type of package or POS display, including furniture.

Box Wizard can be used to create your own templates. It is fast and easy to use with a very intuitive interface.

Furniture

Find more furniture box/stands under **FURNISHINGS / Furniture** such as the **X063 Dillion Table** template and the **X132 Cocktail Table**



Floor Stands

Point of Sale floor stands such as the **X101 Giraffa FSU** template are also available.

The template, as shown below, initially looks like a bottle as it is based on a DXF. The basic elements of this template can be changed to suit your specific requirements – watch the video to see how.

For more details on **Input Edit** and **DXF** refer to [Tutorial 201](#) and [Tutorial 204](#).

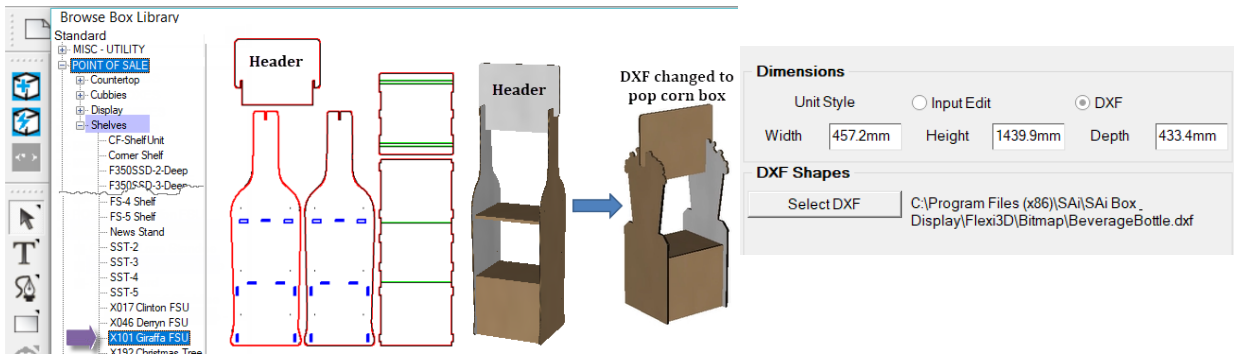

The **X106 Loxo Standee SIGNAGE / Floor** template has holes in the legs that can be drilled to insert rods. The **Hole Settings**, however, relate to the ability to add a hole in the board e.g. shown far right.

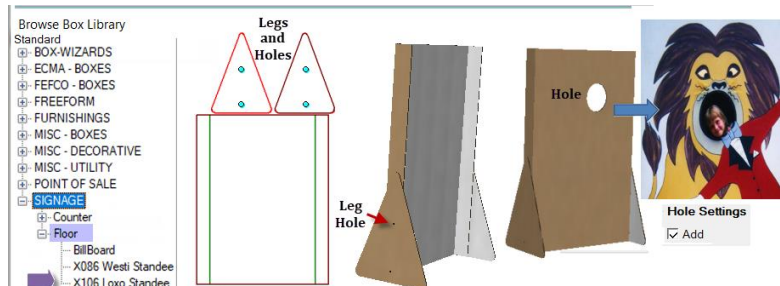

Template Tutorial 208 – Box Inserts

A **Box Insert** goes inside a box when it is folded up and a **DXF cutout** can be added, as shown here in 3D. This can be useful if *the item in the box* is a specific shape.

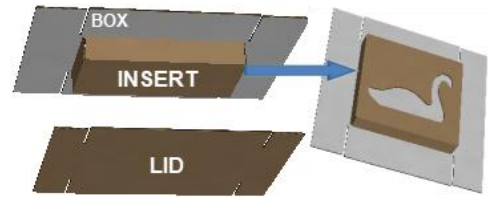

Available in library items FEFCO 0300 to 0308, 0331, 0427.

Step 1

From the Standard Library, select **FEFCO/ 0300** which has optional **'Add lid'** and **'Insert Settings'**.

The image shows a FEFCO 300 in 2D with a **lid** (top right) and then an **Insert** was added (bottom right).

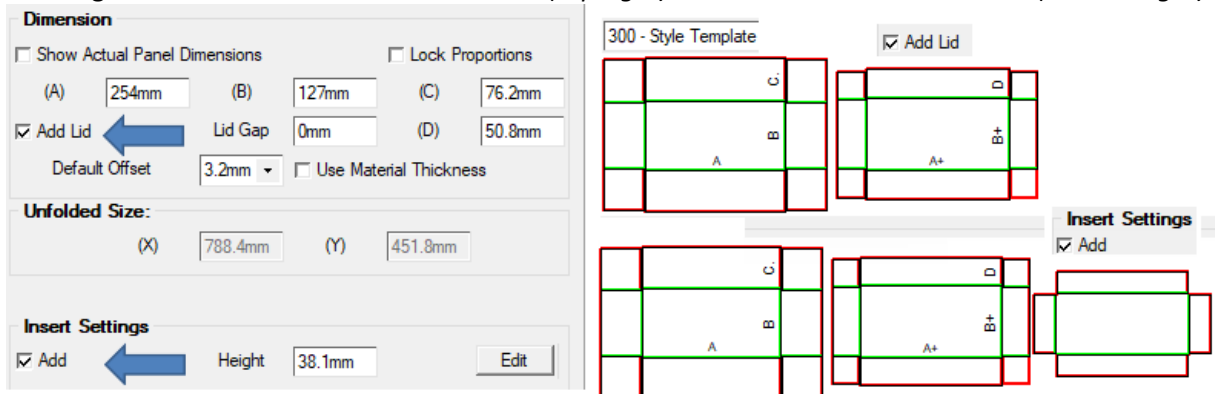

Step 2

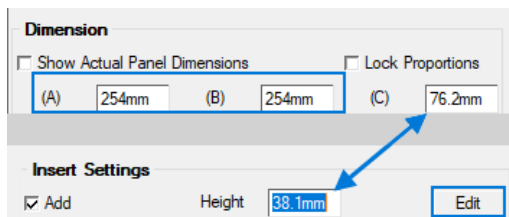

For this tutorial set the **Dimension** to **254mm x 254mm**.

By default, the insert is *half of the height* of the box i.e. Box Dim (C) = 76.2mm and **Insert Height = 38.1mm**

Turn off the **'Add Lid'** option. [See [Add Lid and Gap](#)]

Step 3

Edit Insert

The **Edit** button opens a dialog to allow you to **add a dxf cutout** to the insert.

For this tutorial select the **'Swan.dxf'**. Note the DXF Size is 114.3mm before selection.

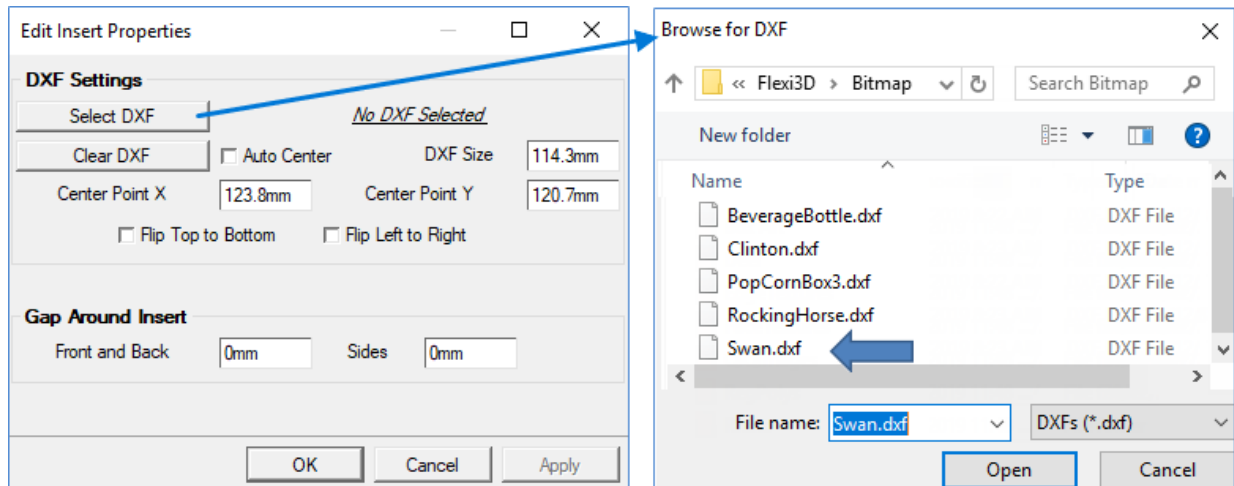

Result

The DXF will be added to the insert so that you can cut it out. *Fig 1* shows the cutout at 114.3mm.

Change the DXF Size to 203.2mm (8in) which will result in *Fig 2*.

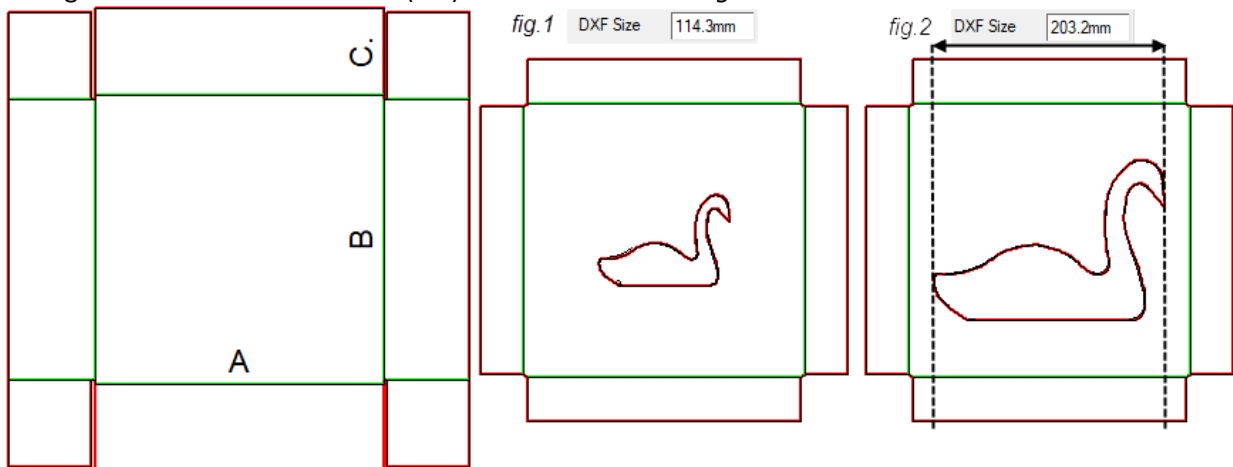

Note: Whenever you add an insert to a box, it is constrained to the size of the box it sits in. The DXF size, in this example 203.2mm, extends to the widest or tallest point of the DXF, shown in *Fig 2*.

Looking at this in Construction mode, (red lines are pictorially added for explanation only) there is a *space at the top and bottom* of the DXF cutout. This is important because you will want to size the DXF based on the largest dimension that will fit it that square, so the DXF itself will maintain the aspect ratio.

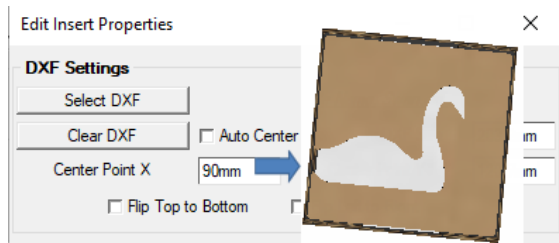
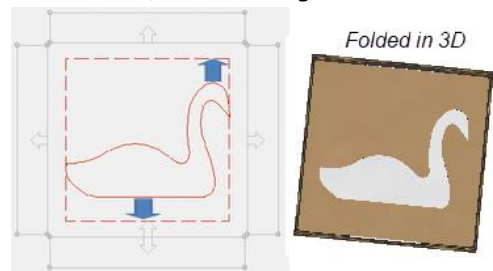

'Center Point (X,Y) controls allow you to change the position of the DXF. The example left, shows Center Point X changed to 90mm.

Use the 'Auto Center' checkbox to re center.

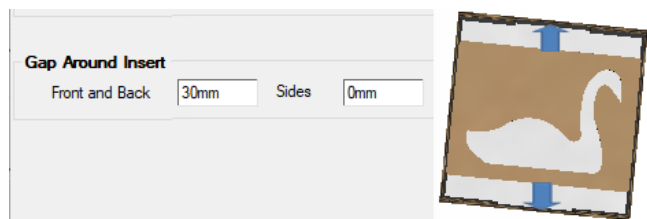

'Gap Around Insert' controls enable you to change the gap at 'Front and Back' (see image) and 'Sides'

Add Lid and Gap Controls

Use the 'Add Lid' checkbox to add a lid. The image below shows the folding of the box in 3D with insert and lid.

You can also adjust the 'Lid Gap'. The boxes below right, have a gap of 0mm and 10mm, respectively.

