

60 2-phase stepper motor

Features: Low noise, high torque, stable operation



86 2-phase stepper motor

Features: Strong moment, high acceleration performance, load shock resistance, strong load capacity, long life



Motor Size (mm)

60 series

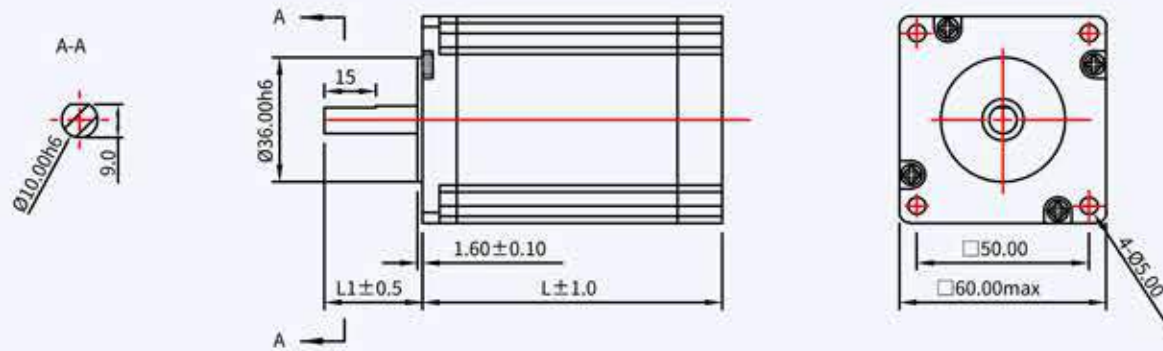

Note: Standard shaft motors are in stock, and non-standard shafts can be customized according to customer requirements.

Motor Size (mm)

86 series

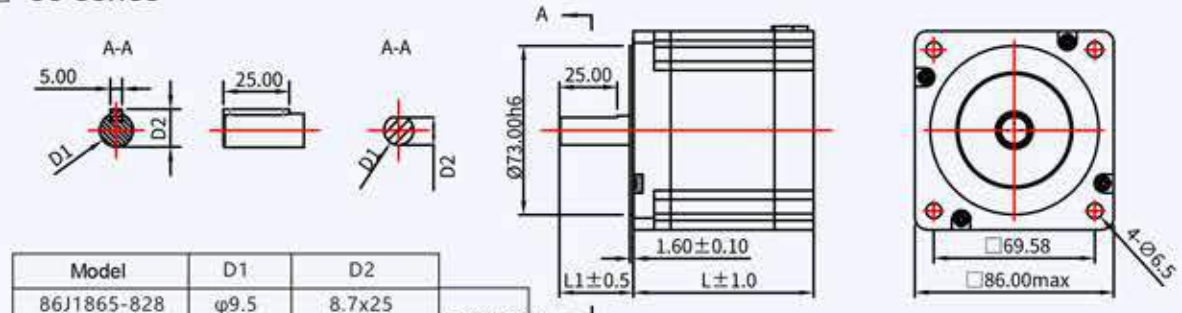

| Model | D1 | D2 | Shaft Type |
|--------------|--------|---------|--------------|
| 86J1865-828 | φ9.5 | 8.7x25 | Flat shaft A |
| 86J1880-460 | φ12.7 | 11.7x25 | Keyway |
| 86J18101-450 | φ12.7 | 14.7x25 | |
| 86J18118-460 | φ12.7 | 14.7x25 | |
| 86J18118-842 | φ12.7 | 14.7x25 | |
| 86J18156-845 | φ15.87 | 17.8x25 | |

Note: Standard shaft motors are in stock, and non-standard shafts can be customized according to customer requirements.

Wiring diagram

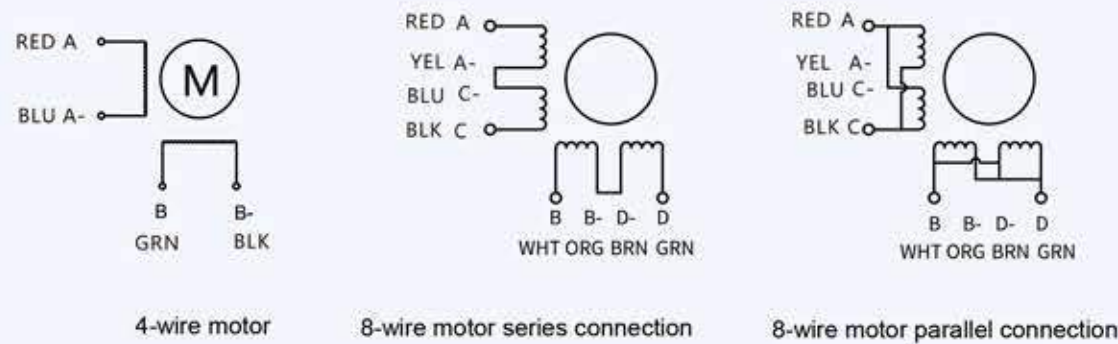

Wiring diagram

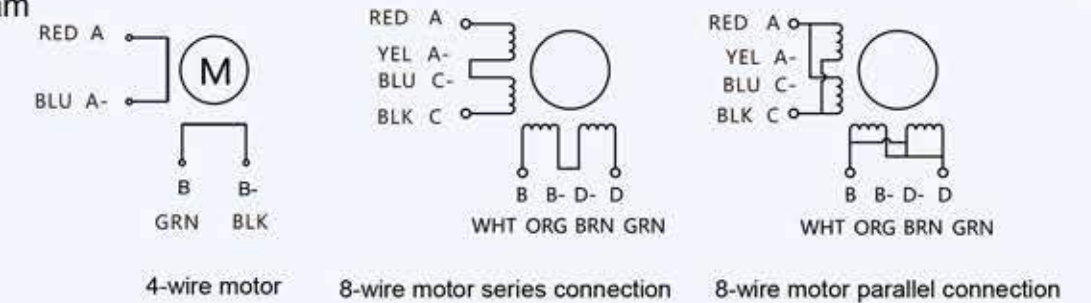

Motor Specifications

| Model | Shaft length L1 | Motor length L | Step angle (deg) | Holding torque (N.m) | Rated current (A) | Phase resistance (ohms) | Phase inductance (mH) | Rotor inertia (g-cm ²) | Insulation class | Number of leads | Weight (KG) | Matching driver |
|--------------|-----------------|----------------|------------------|----------------------|-------------------|-------------------------|-----------------------|------------------------------------|------------------|-----------------|-------------|-----------------|
| 60J1887-440 | 24 | 87 | 1.8 | 3.3 | 4.0 | 0.7 | 2.5 | 900 | B | 4 | 1.4 | 2DM556 |
| 60J18100-440 | 30 | 100 | 1.8 | 3.3 | 4.0 | 0.8 | 3.2 | 950 | B | 4 | 1.7 | 2DM556 |

Note: The company can adjust the motor winding parameters and mechanical dimensions according to customer requirements. If the starting torque of the motor is required to reach the same value as the static torque of the motor, the voltage and current of the corresponding drive need to be increased. Generally, it is recommended to increase by about 30%, depending on the motor. The size of the load and the size of the acceleration.

Motor Specifications

| Model | Shaft length L1 | Motor length L | Step angle (deg) | Holding torque (N.m) | Rated current (A) | Phase resistance (ohms) | Phase inductance (mH) | Rotor inertia (g-cm ²) | Insulation class | Number of leads | Weight (KG) | Matching driver |
|--------------|-----------------|----------------|------------------|----------------------|-------------------|-------------------------|-----------------------|------------------------------------|------------------|-----------------|-------------|-----------------|
| 86J1865-828 | 32 | 66 | 1.8 | 3.2 | 6.5 | 0.24 | 1.5 | 950 | B | 8 | 2.0 | 2DM860 |
| 86J1880-460 | 32 | 80 | 1.8 | 4.5 | 6.0 | 0.36 | 3.1 | 1400 | B | 4 | 2.3 | 2DM860 |
| 86J18101-450 | 32 | 98 | 1.8 | 7.5 | 5.0 | 0.48 | 3.8 | 2300 | B | 4 | 3.25 | 2DM860 |
| 86J18118-460 | 32 | 114 | 1.8 | 8.5 | 6.0 | 0.55 | 7.1 | 2700 | B | 4 | 3.8 | 2DM860 |
| 86J18118-842 | 32 | 118 | 1.8 | 8.5 | 4.2 | 0.56 | 3.0 | 2700 | B | 8 | 3.8 | 2DM860 |
| 86J18156-845 | 32 | 156 | 1.8 | 12.2 | 4.5 | 0.82 | 5.2 | 4000 | B | 8 | 5.4 | 2DM860 |

Note: The company can adjust the motor winding parameters and mechanical dimensions according to customer requirements. If the starting torque of the motor is required to reach the same value as the static torque of the motor, the voltage and current of the corresponding drive need to be increased. Generally, it is recommended to increase by about 30%, depending on the motor. The size of the load and the size of the acceleration.