

550 SERISE

PRODUCT NUMBER

PRODUCT MODEL SIZE TABLE



550 - 0075 G3

G1: 1PH 220V input 3PH 220V output
 G2: 3PH 220V input 3PH 220V output
 G3: 3PH 380V input 3PH 380V output

Rated output power:
 0075:7.5KW

550 series

550 Ser+B5:139ies General Frequency Inverter
 (AC 220V-240V, 3 phases input & 3 phase out put)

Model No.	Drive Motor	Input Current	Output Current	N.W	G.W	Size	Installation
	(kW)	(A)	(A)	(kg)	(kg)	L/W/H(mm)	a/b/d(mm)
550-0007G1	0.75KW	8.2	4	1	1.15	166*83*131	153*65*4mm
550-0015G1	1.5KW	14	7	1	1.15	166*83*131	153*65*4mm
550-0022G1	2.2KW	23	9.6	1	1.15	166*83*131	153*65*4mm
550-0040G1	4.0KW	40	17	2.5	2.9	245*120*173	233*80*4mm

550 Series General Frequency Inverter
 AC 380V-450V, 3 phases input & 3 phase out put)

Model No.	Drive Motor	Input Current	Output Current	N.W	G.W	Size	Installation
	(kW)	(A)	(A)	(kg)	(kg)	L/W/H(mm)	a/b/d(mm)
550-0007G3	0.75KW/1.5KW	3.4	2.1	1	1.15	166*83*131	153*65*5mm
550-0015G3	1.5KW/2.2KW	5	3.8	1	1.15	166*83*131	153*66*5mm
550-0022G3	2.2KW/3.0KW	6.8	6	1	1.15	166*83*131	153*67*5mm
550-0040G3	4.0KW/5.5KW	10	9	2.4	2.7	245*120*173	233*80*5mm
550-0055G3	5.5KW/7.5KW	15	13	2.4	2.7	245*120*173	233*81*5mm
550-0075G3	7.5KW/11KW	20	17	2.5	2.9	245*120*173	233*82*6mm
550-0110G3	11KW/15KW	26	25	3.5	3.9	281*145*185	267.5*125.5*6mm
550-0150G3	15KW/18.5KW	35	32	6.1	7	320*203*205	305*187*6mm
550-0185G3	18.5KW/22KW	38	37	6.1	7	320*203*205	305*188*6mm
550-0220G3	22KW/30KW	46	45	6.2	7.2	320*203*205	305*189*6mm
550-0300G3	30KW/37KW	62	60	6.3	7.4	320*203*205	305*190*6mm
550-0370G3	37KW	76	75	12.7	14	430*250*240	410*190*6mm
550-0450G3	45KW/55KW	92	90	21	22	506*290*250	490*240*8mm
550-0550G3	55KW/75KW	112	110	23.5	25.2	490*330*263	465*237*8mm
550-0750G3	75KW/90KW	157	150	23.8	26	490*330*263	465*237*8mm
550-0900G3	90KW/110KW	180	176	31.7	43	600*397*263	575*240*8mm
550-1100G3	110KW/132KW	214	210	31.7	43	600*397*263	575*240*10mm
550-1320G3	132KW/160KW	256	253	44.6	54.5	695*380*265	670*240*10mm
550-1600G3	160KW/185KW	307	304	79	89	750*460*360	720*380*10mm
550-1850G3	185KW/200KW	350	350	80	90.8	750*460*360	720*380*10mm
550-2000G3	200KW/220KW	385	377	80	90.8	750*460*360	720*380*10mm
550-2200G3	220KW/250KW	430	426	80	90.8	750*460*360	720*380*10mm
550-2500G3	250KW/280KW	468	465	141	152.7	1053*638*410	230*695*10mm
550-2800G3	280KW/315KW	525	520	141	152.7	1053*638*411	230*695*10mm
550-3150G3	315KW/350KW	590	585	143	155	1053*638*412	230*695*10mm
550-3500G3	350KW/400KW	665	650	180	197	1210*768*401	230*695*10mm
550-4000G3	400KW/450KW	785	725	180	197	1210*768*401	230*695*10mm
550-4500G3	450KW/500KW	840	820	183	200	1210*768*401	230*695*10mm
550-5000G3	500KW/560KW	880	900	183	200	1210*768*401	230*695*10mm
550-5600G3	560KW/630KW	980	1000	360	400	1790*960*407	--
550-6300G3	630KW/710KW	1130	1100	360	400	1790*960*407	--
550-7100G3	710KW/800KW	1290	1200	360	400	1790*960*407	--
550-8000G3	800kw/900kw	1450	1400	360	400	1790*960*407	--

SYSTEM DIAGRAM

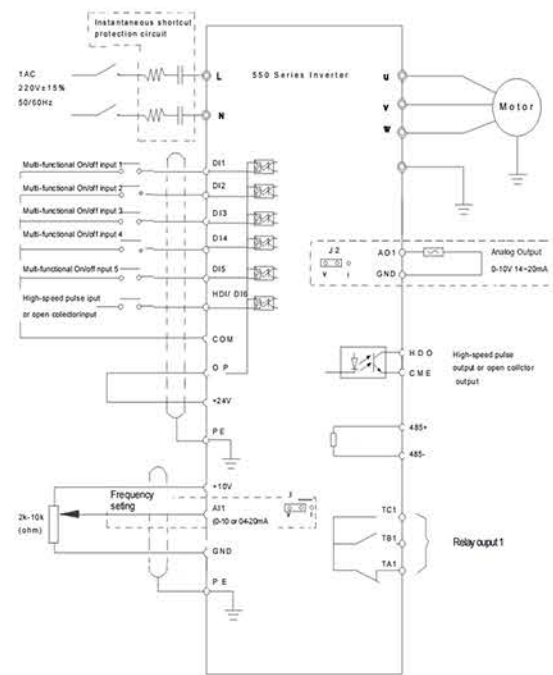

PRODUCT DETAILS

HUMANIZED DESIGN

Reasonable layout
 easy to use
 8-segment digital tube display



PCB DESIGN

Reasonable layout
 Imported components
 Imported three anti-paint
 Dustproof
 Moisture proof
 Antistatic

Internal details

Stable and reliable device
 High quality
 Good craftsmanship



DIMENSIONS

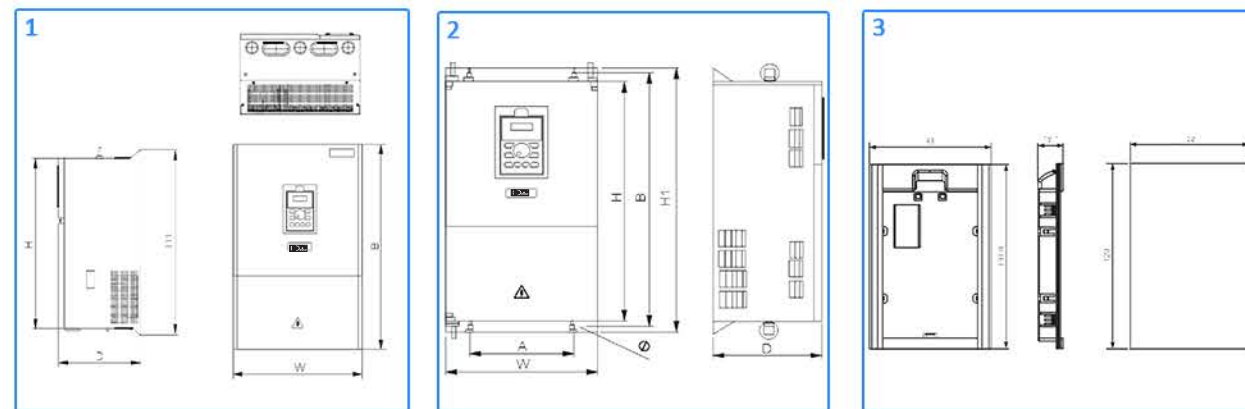

FAST DELIVERY
 SAFE ARRIVAL