

bCom S Label Printing Scale

Better than the best



Fast, accurate weighing and service. Ergonomic design, solid, reliable and easy operation.

bCom S is a highly cost effective product designed for supermarket and retail grocery. The easy, solid and smart features help simplifying the process of weighing, selling and achieving safe transactions.

METTLER TOLEDO

Cost-effective product to satisfy supermarket and food retailer

METTLER TOLEDO bCom S label printing scale convinces with its superb operability, powerful functions and easy maintenance, which makes retailers more efficient.

Powerful application and solid hardware interface help retailers to professionally manage their business. Open label design and seamless application interaction sets bCom S apart from others.

Easy Operation



Outstanding readability, Customized keyboard, logical menu structure and high performance printer make operating easier.

Solid and Durable



Stronger than IPX8 keyboard. Enhanced salt-spray proof and ultra-long life key, More than 30KV ESD resistance.

Smart Management



DHCP for automatic IP setup, UX-friendly scale management PC tool and powerful function application help the retailer business.

One key to switch between sales mode and pre-package mode

Larger Memory

- bCom S memory 10MB

Powerful Keyboard

- More than IPX8
- Enhanced salt-spray proof
- Ultra-long life key

Customizable Keyboard

- Key mapping
- 2 layer*70 pre-set keys =total 140 pre-set keys
- Configurable function key

Solid Structure

- Industrial quality electronics
- 304 stainless steel platter
- Suitable for food use

Outstanding Readability (Lifetime > 30,000hrs)

- Orange Dot-matrix +segment display for rich content
- bright and attractive, good readability under the sunlight

Fast, Accurate and Steady Weighing Process

- Over load protection 400% max
- Easy clean housing

Energy Saving

- Standby power consumption less than 0.5W



Comprehensive Network Communication

- Stable, secure
- DHCP for automatic IP setup
- Fully compatible with the existing MT legacy products in the same LAN

High Performance Printer Module

- Spring open print head, easy to clean
- Drawer pull out mechanism for easy paper change and maintenance
- Effective printing width 40-62mm
- Small label printing with a minimum size of 25mm
- Automatic identification of label size

Convenient Setup and Configuration UX-friendly PC tool

- Upgrade firmware automatically by clicking one key
- Clone the data of one scale to other scales

USB Mass Storage

- Simple data transfer from scale/scale
- Update item data
- Copy scale configuration
- Update firmware
- Backup/restore scale data

Feature-rich Software

- Experience from many years of customer requirements
- Sales and prepack
- QR code (reduce the loss of print head and improve the probability of scanning)
- Support small label, reduce the cost of consumables
- Rapid price change
- Regulatory compliance (e.g. traceability)
- Monitor print head and keyboard usage, provide early warning, reduce downtime and maintenance cost



Technical Parameters

bCom S Label Printing Scale

Operator Display

- High contrast LCD Dot-Matrix Display
- Weight: 6 digits
- Price/kg: 6 digits
- Total: 7 digits
- Tare: 5 digits
- Text Line: 16 Alphanumeric characters (dot matrix line)

Customer Display

- High contrast LCD Dot-Matrix Display
- Weight: 6 digits
- Price/kg: 6 digits
- Total: 7 digits
- Tare: 5 digits
- Text Line: 16 Alphanumeric characters (dot matrix line)

Housing

- Die-cast aluminium housing
- Stainless steel platter
- Adjustable feet

Keyboard

- Easy to clean membrane keyboard
- 98 membrane keys with pressure point
- 70 preset keys with two layer for assigning 140 PLUs
- Separate individually configurable function keys

Printer

- Printing speed: 125mm/s
- Printing resolution: 203dpi
- Printing width: 40~62mm
- Minimum printing length: 25mm
- Roller diameter: Max to 120mm
- Automatically recognize label size

Interface

- 1 x USB interface
- 1 x RS232 serial interfaces
- 1 x RJ45 Ethernet interface
- 1 x RJ11 interface (12V) for controlling the cash register

Network and Data Transmission

- 10/100 Base T Ethernet, TCP/IP, USB, DHCP, Wireless LAN*
- DHCP support for automated network setup
- Hubless network connection
- Automatic backup
- Smart management functions for transmitting and securing production and configuration data via USB stick

Weighing Range

- 6/15kg 15/30kg

Graduation

- 2/5g 5/10g

Minimum Capacity

- 40g 100g
- Automatic zero-setting

Housing Color

- Dark grey

Power Consumption

- 100~240V AC 50/60Hz
- Standby power consumption: < 0.5W
- Working efficiency: >85%

Working Environment

- -10°C~+40°C, RH< 95%, No condensation

Data Storage 10MB Memory

Outling Dimension L371 x W438 x H457



* Optional

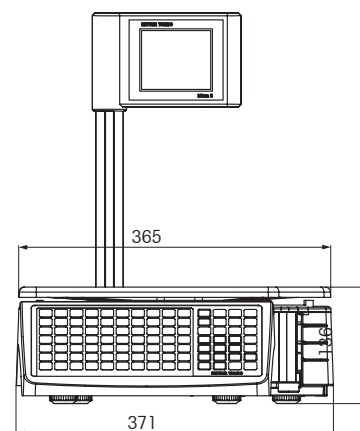
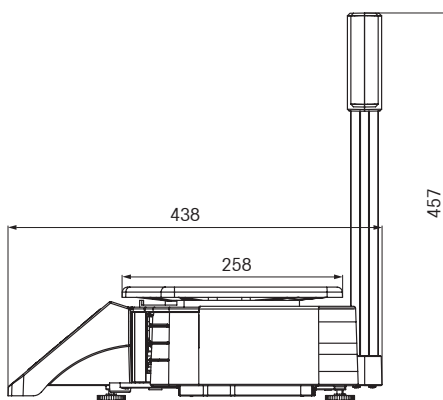

www.mt.com/retail

For more information



Mettler-Toledo (Changzhou)

111 West Taihu Road Changzhou
Jiangsu 213125 CHINA
Tel. +86-519-8664-2040
Fax +86-519-8664-1991

Subject to technical changes.
© 2021 Mettler-Toledo (Changzhou)
Printed in P. R. China 2021/06