

Refrigerated Air Dryer

Series IDFA ■ E



NEW
Series **IDFA**

Air flow capacity

Increased up to the

max 40%

(SMC comparison)

Power consumption

Decreased up to the

max 40%

(SMC comparison)

Refrigerant

R134a (HFC)

R407C (HFC)

Coefficient of destruction
for ozone is zero

Heat exchanger



Improved corrosion resistance with
the use of stainless steel, plate type
heat exchanger (IDFA4E to 75E)

Built-in auto drain

Previous IDF



External
mounting
auto drain

New IDFA



Built-in auto drain

Specification		Model	IDFA3E	IDFA4E	IDFA6E	IDFA8E	IDFA11E	IDFA15E	IDFA22E	IDFA37E	IDFA55E	IDFA75E	
			-23	-23	-23	-23	-23	-23	-23	-23	-23	-23	
Rated Condition	Air Flow Rate (ANR) (Note 1) ℓ /min		283	566	833	1516	1866	2800	4233	6366	8500	13700	
	At Outlet Pressure Dew Point of 10°C												
	Operating Pressure (Mpa)							0.7					
	Inlet Air Temperature (°C)							35					
Operating Range	Ambient Temperature (°C)							25					
	Working Fluid							Compressed Air					
	Inlet Air Temperature (°C)							5 to 50					
	Inlet Air Pressure (MPa)							0.15 to 1.0					
Electric Specification	Ambient Temperature (°C)							2 to 40 (Relative Humidity of 85% or less)					
	Power supply voltage							Single-phase 230VAC \pm 10% 50Hz					
	Operating Current (Note 2) (A)		1.2	1.2	1.2	1.4	2.7	3.0	4.3	5.4	7.9		
	Power Consumption (Note 2) (W)		180	180	180	208	385	470	760	1130	1700		
	Circuit Breaker (Note 3) (A)				5				10		20		
Condenser												Air-cooled type	
Refrigerant												R134A (HFC)	R407C (HFC)
Auto drain (Float type)			AD38 (normally closed)										AD48 (normally open)
Port size			Rc 3/8	Rc 1/2		Rc 3/4		Rc 1	R 1	R 1 1/2		R 2	
Accessory (kg)						Hexagon nipple							
Weight (kg)			18	22	23	27	28	46	54	62	100	116	
Coating color													Body panel: White 1 Base : Gray 2
Compliant standards													EU directive compliant (with CE marking)
Applicable Compressor kW (Standard)			2.2	3.7	5.5	7.5	11	15	22	37	55	75	

Note 1: The data for ℓ /min (ANR) is referring to the conditions of 20°C, 1atm. Pressure & relative humidity of 65%.

Note 2: the value is that of under specified condition.

Note 3: Install GFCI breaker that comes with sensitivity of 30mA

Note 4: When short period power shortage (including instantly recovered shortage) is recovered.

It may take a longer starting period the un-usual starting or may not start due to the protective devices.

Construction Principle (Circuit for Air / Refrigerant)

IDFA3E

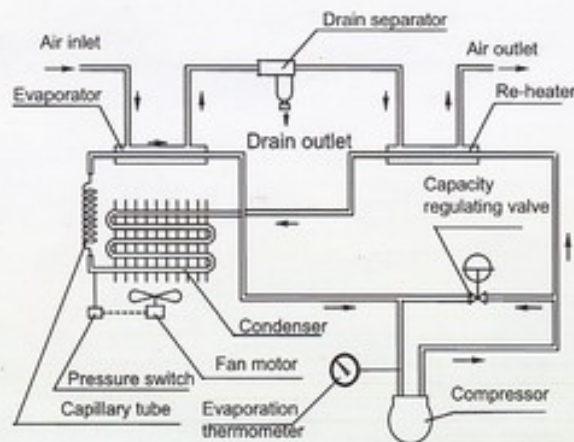

IDFA4E to 15E

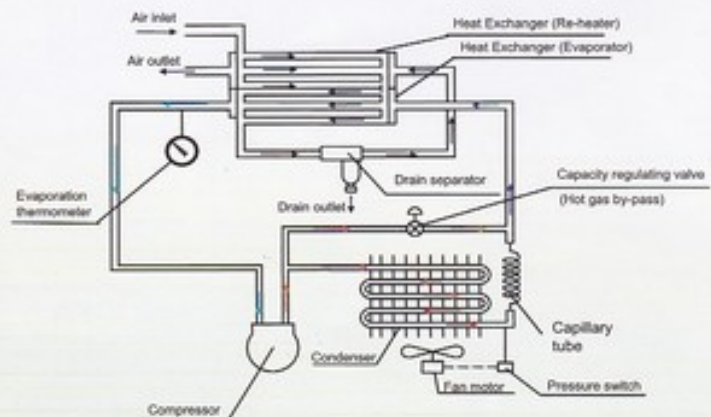

IDFA22E to 75E

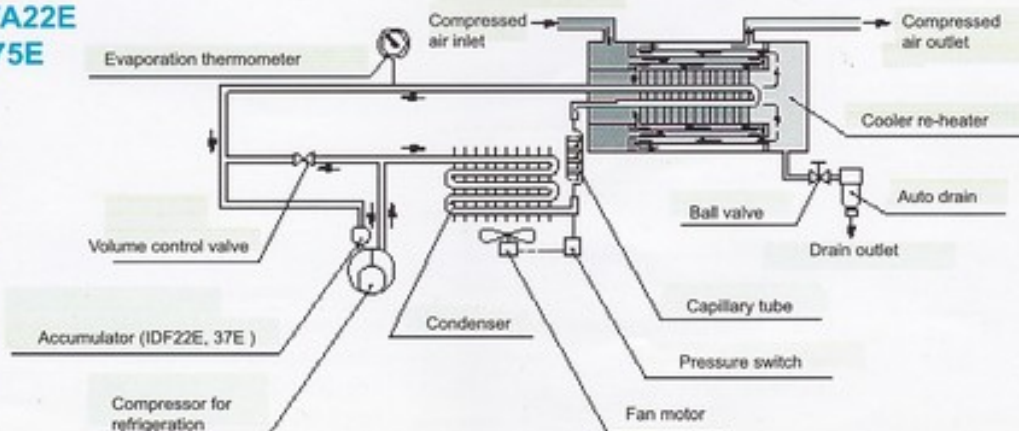

IDFA3E to 15E

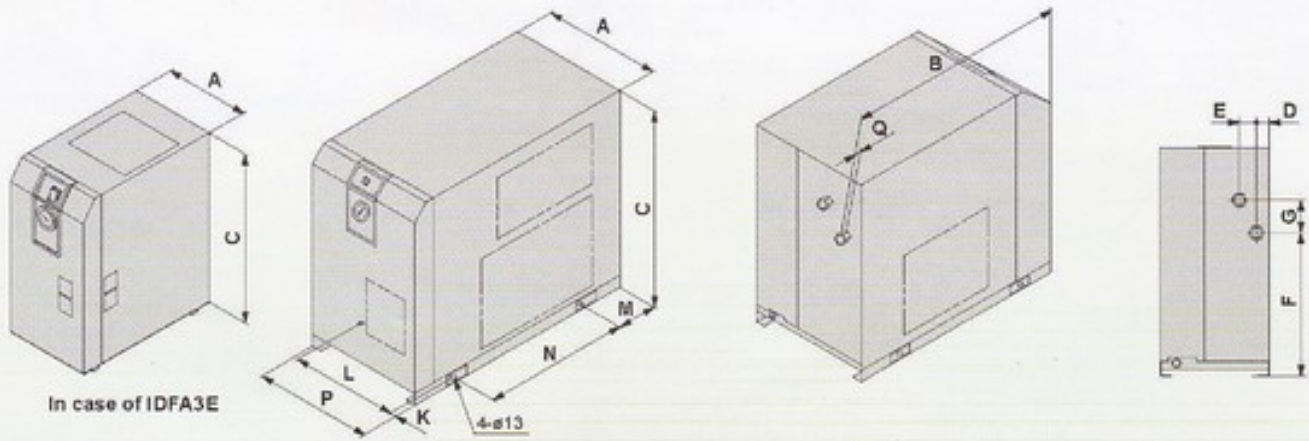

IDFA22E to 37E

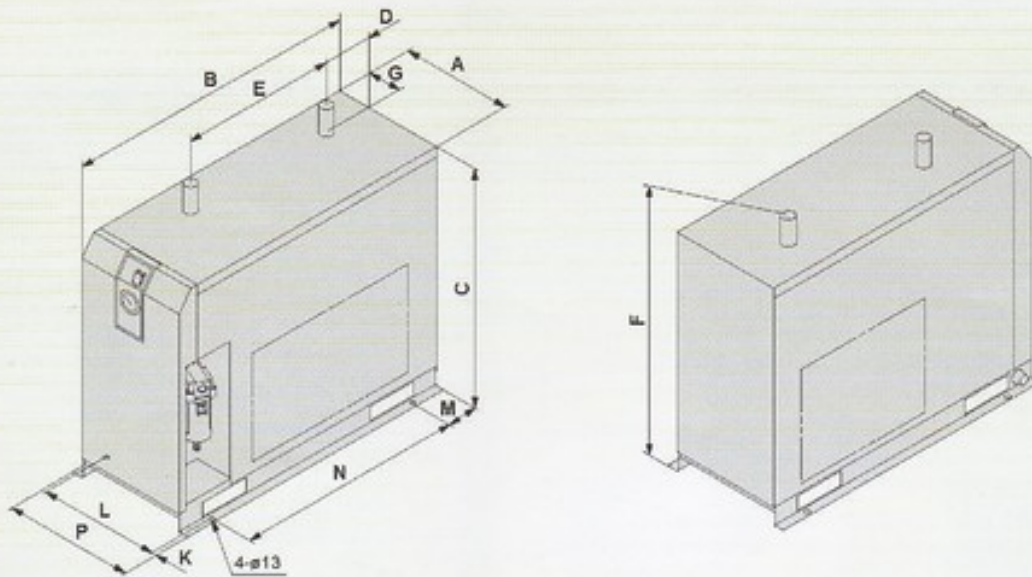

Dimensions

(mm)

Model	Port size	A	B	C	D	E	F	G	K*	L*	M*	N*	P	Q
IDFA3E	Rc 3/8	226	410	473	67	125	304	33	36	154	21	330	-	15
IDFA4E	Rc 1/2	270	453	498	31	42	283	80	15	240	80	275	314	13
IDFA6E	Rc 3/4		455	568			355					300		15
IDFA8E	Rc 3/4		485	568			355					300		15
IDFA11E	Rc 3/4	300	603	578	41	54	396	87	13	314	85	380	340	16
IDFA15E	Rc 1											380		380
IDFA22E	R 1	290	775	623	134	405	698	93	13	314	85	600	340	-
IDFA37E	R 1½		855	623								680		680

* Meaning the foot dimensions for the IDFA3.

IDFA55E to 75E

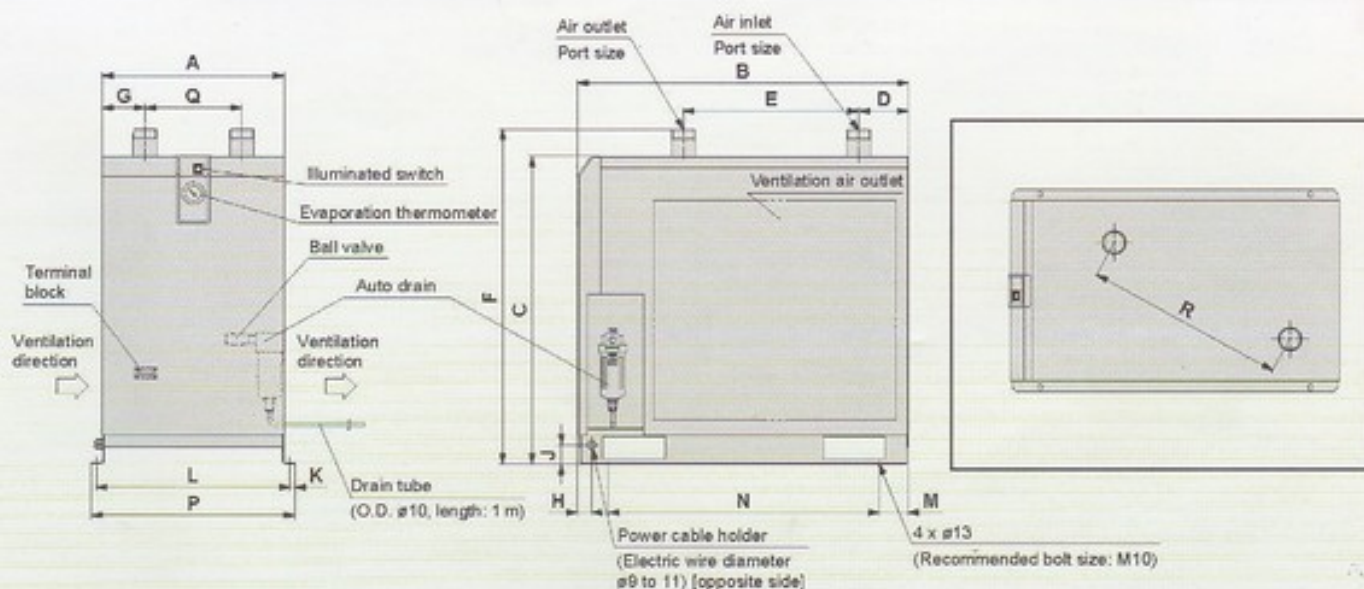

Dimensions

(mm)

Model	Port size	A	B	C	D	E	F	G	H	J	K	L	M	N	P	Q	R
IDFA55E	R 2	470	855	800	128	455	868	110	36	50	13	500	75	700	526	250	519
IDFA75E		900		968													

Model Selection Guide

The corrected air flow capacity, which considers the user's operating conditions, is required for selecting the air dryer. Please select using the following procedures.

- 1 Read the correction factor.**
Obtain the correction factor A to D suitable for your operating condition from the table below.
- 2 Calculate the corrected air flow capacity.**
Obtain the corrected air flow capacity from the following formula.
Corrected air flow capacity = Air consumption × (Correction factor A × B × C)
- 3 Select the model**
Select the model which air flow capacity exceeds the corrected air flow capacity using the specification table. For air flow capacity, refer to the data D below)

Data B:
Ambient Temperature

Ambient temperature (°C)	Correction factor	
	IDFA3E~11E	IDFA15E~75E
20	1.1	1.1
25	1	1
30	0.91	0.97
35	0.83	0.89
40	0.79	0.77

Data D:
Air Flow Capacity

Model	Air flow capacity (ℓ/min) [ANR]										
	IDFA3E	IDFA4E	IDFA6E	IDFA8E	IDFA11E	IDFA15E	IDFA22E	IDFA37E	IDFA55E	IDFA75E	
Outlet air pressure dew point	3°C	200	400	600	1083	1333	2000	3033	4550	6500	11000
	7°C	250	516	766	1383	1683	2533	3850	5783	7200	12000
	10°C	283	566	833	1516	1866	2800	4233	6366	8500	13700

Data A:
Inlet Air Temperature

Inlet air temperature (°C)	Correction factor
5 to 25	1.30
30	1.25
35	1
40	0.83
45	0.7
50	0.6

Data C:
Inlet Air Pressure

Inlet air pressure (MPa)	Correction factor	
	IDFA3E~11E	IDFA15E~75E
0.3	0.8	0.72
0.4	0.87	0.81
0.5	0.92	0.88
0.6	0.96	0.95
0.7	1.00	1.00
0.8	1.04	1.06
0.9	1.07	1.11
1.0	1.1	1.16
1.2	1.16	1.21
1.4	1.21	1.25
1.6	1.25	1.27