



**Digital
 Dual Function Controller EDJ_MIC
 for humidity and temperature
 Input: 2 x 0 ... 20mA
 with integrated sensor power supply**

Description

The controller EDJ_MIC for humidity and temperature consists of two integrated, digital microprocessor controllers and also an integrated 15-VDC power supply for the sensors.

The humidity temperature sensor type TFG80J, TFK80J or TF-K120J (refer to page 2) with output signals 0 ... 20 mA is used as the readings recorder. The humidity and temperature values are displayed digitally on the EDJ_MIC controller as actual values.

The EDJ_MIC controller can be used as a two or three point controller. The output states are shown by LEDs.

The user-friendly EDJ_MIC controller is really very easy to use. It has been pre-programmed in the factory so that no particular previous knowledge of control engineering is required to be able to solve simple control tasks. After successfully connecting up and entering the target values, it is ready for immediate use to control humidifying or dehumidifying as well as heating and cooling.

Apart from that, the controller also allows you to solve complex control tasks. By using the keyboard to enter the parameters, you can set the PID characteristics of the controller and also the switching time, the switching hysteresis, the working point and also the output limiting.

The filters on the controller inputs filter out changes in the input signal which are too fast. The filter time constant can be set to between 0.0 ... 100.0 sec by pressing a button. Thus the control is no longer affected by distortions and transients.

A special feature of the EDJ_MIC is the self-optimisation. This means that the controller independently determines the optimal control parameters for a PID or PI controller in the given control environment.

The humidity and temperature controller type EDJ_MIC provides you with a control unit which can be used to solve a wide range of problems. The EDJ_MIC controller simultaneously acquires and controls the humidity and temperature and is thus suitable for controlling e.g. computer rooms, air conditioning and maturing chambers, monitoring and regulating the ambient conditions at print shops, in the textile industry, the film industry, in hothouses, in warehouses and many other places.

Technical Data

Power supply	230VAC, 11VA (incl. sensors), 45...55Hz
Controller type	two or three point controller
controller structures	PD/PI/PID
A/D-transducer	resolution > 15 Bit
Data storage	EEPROM
Sampling time	210ms
Measurement accuracy	≤ 0,1% / 100ppm/K
Outputs	relay
Make contact (NO contact)	
	3A at 250 VAC resistive load
	150,000 switches at rated load
Output sensor supply	15 VDC max. 60 mA
Target value display	4-digit can be retrieved using keys
Actual value display	4-digit
Housing	panel housing to IEC 61554 black
Housing dimensions (HxBxT mm)	144 x 72 x 135
Contacts	on the back using pluggable screw terminals
electromagnetic compatibility	EN 61 326
Ambient temperature	+10...+50°C
Protective system, front	IP50
rear	IP20

Technical Data for Humidity

Input	0...20mA
Control range	0...100 %rh
Display range	00,0 ... 100,0 %rh
Output	2 x NO contacts

Technical Data for Temperature

Input	0...20mA
Control range	-10...+90°C
Display range	-10,0...90,0°C
Output	2 x NO contacts

For more complex control tasks and a wide range of sensors, our type EDR_MIC is available.

Please ask for the detailed data sheet.

Connecting Diagram

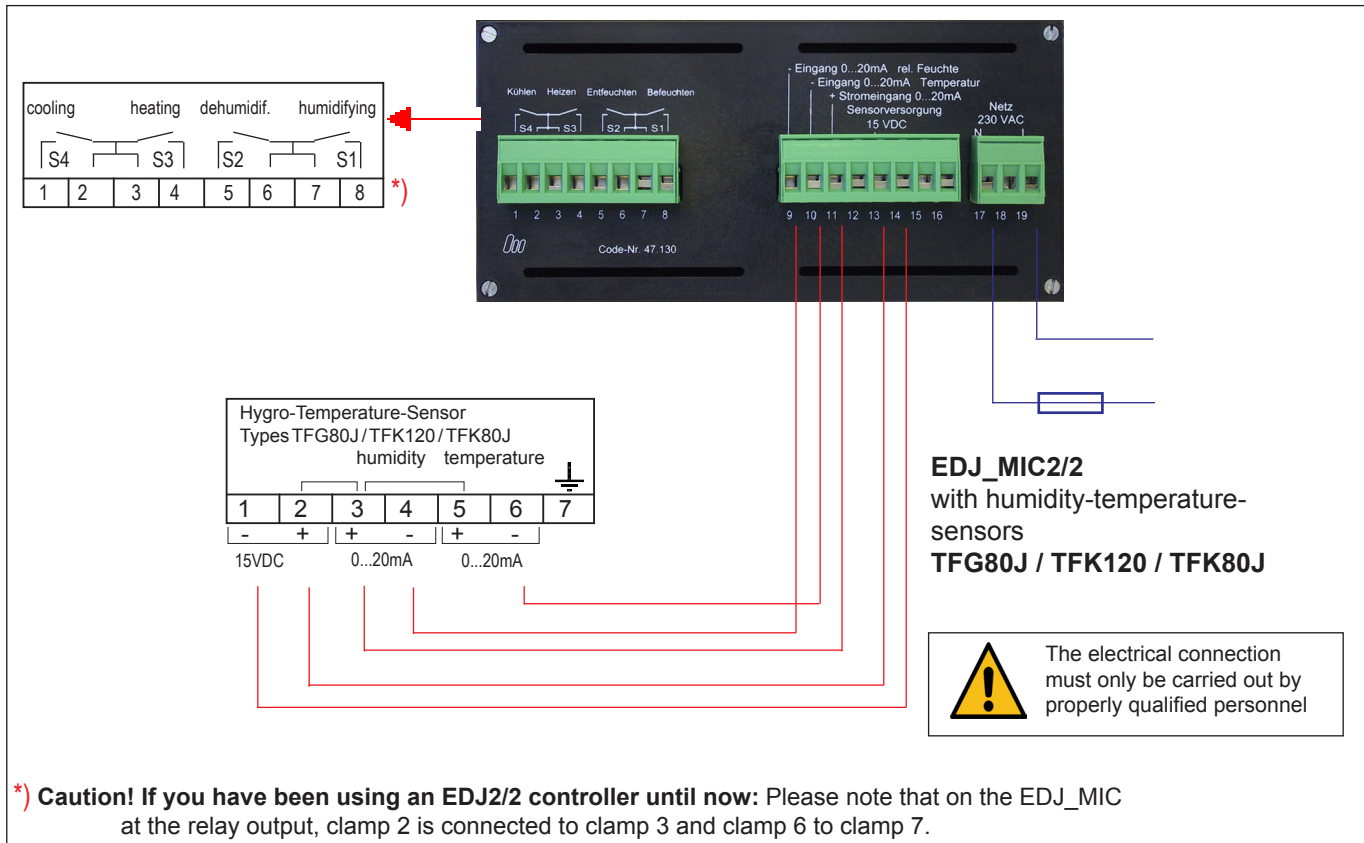

Dimensions

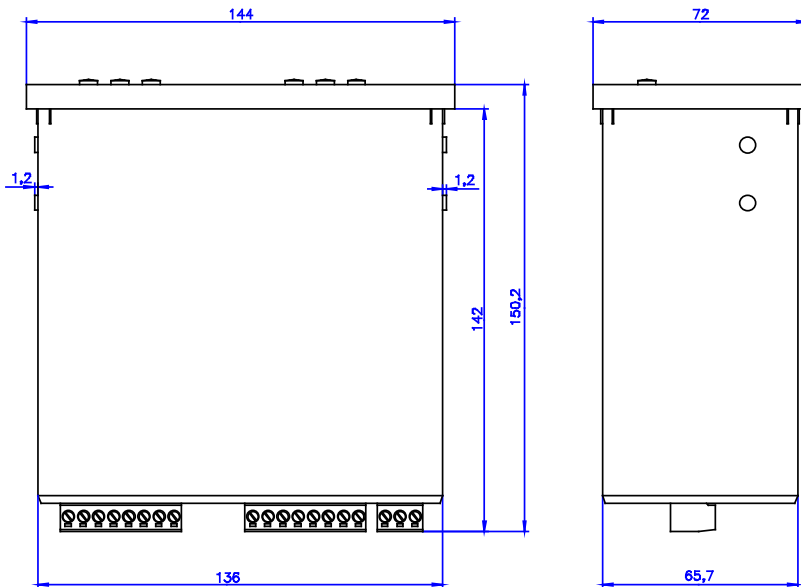

Sensor Data

Sensor Type	Measured Variable	Design	Order No.	for Controllers
TFG80J	Humidity and temperature	duct version	44623030	EDJ_MIC2/2
TFK80J	Humidity and temperature	duct version	58623030	EDJ_MIC2/2
TFK120J	Humidity and temperature	room version	59623030	EDJ_MIC2/2

For technical data on the sensors please refer to the respective data sheets!

Operating the Controller

There are three buttons on the front of each of the two controllers: **P ▲ ▼**

Use the **P** button to select the required parameter. The display changes between the description of the parameter and the value. You use the **▲** or the **▼** button to respectively increase or decrease the value for the parameter.

The new value will be automatically saved after 2 sec. approx.

Switching on, setting the target value

After switching on, first of all a display check is carried out for 3 s. After that, the four-digit, seven segment displays show the actual values for the humidity and the temperature (**normal display**).

After pressing the **P** button, the first parameter will appear: **SP** the target value (**user interface**). It is set by pressing the **▲** or the **▼** button and the new target value set is accepted after approx. 2 s. The normal display with the actual value is then retrieved by pressing the **P** button again or returns automatically after approx. 30 s.

Setting additional parameters

To avoid the parameters being inadvertently changed by people who are not experts, the **Parameter interface**, in which thirteen more parameters can be set, has been protected with a simple locking mechanism: You can switch to the **Parameter interface** by pressing the **P** button for approx. 3seconds, either directly with the normal display, or on the user interface. The other parameters are also selected by pressing the **P** button and are then set with the **▲** or the **▼** button. Here the new values are also accepted after approx. 2 s, which is confirmed by the display flashing briefly once. After the last parameter, the SP (target value) is shown again at the end before normal display is resumed.

For most applications the EDJ_MIC controller works correctly with the factory settings. The user only has to set „SP“, „db“, „HYS.1“, „HYS.2“ and possibly „df“. If the target value (SP) is now changed after making this adjustment, the control switching points do not move relatively to each other. The target value is always at half the contact distance (db) (refer to graphics p. 4).

We recommend that you do not change the other parameters without sufficient expertise in control engineering.

Self-optimization

In many cases, with this function the controller can determine the optimal parameters for a PID or PI controller. The following controller parameters are defined: r_t , d_t , $P_{b.1}$, $P_{b.2}$, CY_1 , CY_2 , d_f . Depending on the size of the system deviation, the controller chooses between two processes **a** or **b**.

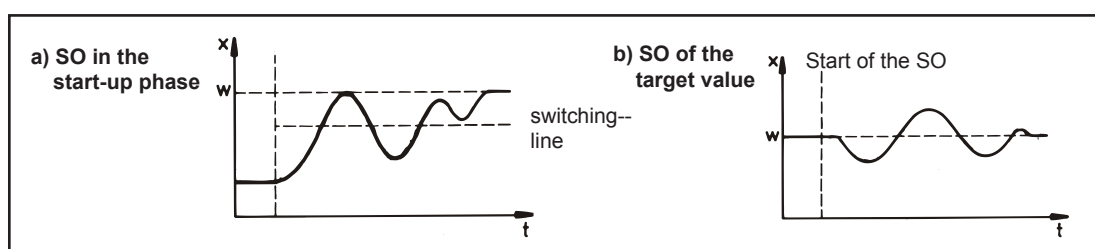

Caution: Please make sure you make a note of the parameters set before implementing self-optimization!

To start self-optimization, the **▲ ▼** buttons must be pressed simultaneously for 3 s. On the display „tunE“ and the actual value are shown alternately. Self-optimization is ended automatically or can be cancelled by briefly pressing the **▲ ▼** buttons simultaneously

Please note that the relative humidity depends on the temperature. For this reason it is necessary to start self-optimization of humidity control at a constant temperature!

Alarm messages

The display for the process value flashes **1999**. The cause may be a over/underrange of the process value.

Parameter

Parameter	Setting range	Description	Settings	
			factory-made	customer
SP	20...100%rh for humidity -10...90 °C for temperature	setpoint	40,0%rh 25,0°C	
Pb.1	0,0...999,9	proportional band 1 (controller output 1) P-action	0,0	
Pb. 2	0,0...999,9	proportional band 2 (controller output 2) P-action	0,0	
dt	0...9999s	derivative time D-action	80s	
rt	0...9999s	reset time I-action	343s	
CY 1	1,0...999,9s	cycle time 1 (controller output 1)	20,0s	
CY 2	1,0...999,9s	cycle time 2 (controller output 2)	20,0s	
db	0,0...100,0	contact spacing	3,0 [%rh without °C]	
HYS.1	0,0...999,9	switching differential 1 (controller output 1)	1,0 [%rh without °C]	
HYS.2	0,0...999,9	switching differential 2 (controller output 2)	1,0 [%rh without °C]	
Y .0	-100...100%	working point (base load)	0%	
Y .1	0...100%	output limiting maximum output level	100% *	
Y .2	-100...100%	output limiting minimum output level	-100% *	
dF	0,0...100,0S	filter time constant	0,6s	

* In case of controllers without control structure (Pb.1 = 0 or Pb.2 = 0) settings have to be Y.1 = 100% and Y.2 = -100%.

