



# Design Guide

## VLT® HVAC Basic Drive FC 101

Contents

<b>1 How to Read this Design Guide</b>	<b>4</b>
1.1.1 Legal Information	4
1.1.2 Available Literature for VLT® HVAC Basic Drive	4
1.1.3 Symbols	5
1.1.4 Abbreviations	5
1.1.5 Definitions	6
1.1.6 Power Factor	8
<b>2 Introduction to VLT® HVAC Basic Drive</b>	<b>9</b>
2.1 Safety	9
2.1.2 Safety	9
2.2 CE Labeling	10
2.3 Air humidity	11
2.4 Aggressive Environments	11
2.5 Vibration and Shock	12
2.6 Advantages	12
2.7 Control Structures	24
2.7.3 Local (Hand On) and Remote (Auto On) Control	24
2.8 General Aspects of EMC	31
2.9 Galvanic Isolation (PELV)	36
2.10 Earth Leakage Current	37
2.11 Extreme Running Conditions	37
<b>3 VLT® HVAC Basic Drive Selection</b>	<b>40</b>
3.1 Options and Accessories	40
3.1.1 Local Control Panel (LCP)	40
3.1.2 Mounting of LCP in Panel Front	40
3.1.3 IP21/TYPE 1 Enclosure Kit	41
3.1.4 Decoupling Plate	42
<b>4 How to Order</b>	<b>43</b>
<b>5 How to Install</b>	<b>48</b>
5.1.1 Dimensions	48
5.1.2 Shipping Dimensions	50
5.1.3 Side-by-Side Installation	51
5.2 Electrical Data	52
5.2.1 Electrical Overview	52
5.2.2 Electrical Installation in General	53
5.2.3 Connecting to Mains and Motor	54

5.2.4 Fuses	60
5.2.5 EMC-Correct Electrical Installation	62
5.2.6 Control Terminals	64
<b>6 How to Programme</b>	<b>65</b>
6.1 Programming with MCT 10 Setup Software	65
6.2 Local Control Panel (LCP)	65
6.3 Menus	66
6.3.1 Status	66
6.3.2 Quick Menu	66
6.3.3 Start-up Wizard for Open Loop Applications	66
6.3.4 Main Menu	75
6.4 Quick Transfer of Parameter Settings between Multiple Frequency Converters	75
6.5 Read-out and Programming of Indexed Parameters	75
6.6 Initialise the Frequency Converter to Default Settings in two Ways	76
<b>7 RS-485 Installation and Set-up</b>	<b>77</b>
7.1.1 Overview	77
7.2 FC Protocol Overview	78
7.3 Network Configuration	79
7.4 FC Protocol Message Framing Structure	79
7.4.1 Content of a Character (byte)	79
7.4.2 Telegram Structure	79
7.4.3 Telegram Length (LGE)	79
7.4.6 The Data Field	79
7.4.13 Process Words (PCD)	82
7.5 Examples	82
7.6 Modbus RTU Overview	82
7.6.1 Assumptions	82
7.6.2 What the User Should Already Know	83
7.6.3 Modbus RTU Overview	83
7.6.4 Frequency Converter with Modbus RTU	83
7.7 Network Configuration	83
7.8 Modbus RTU Message Framing Structure	83
7.8.1 Frequency Converter with Modbus RTU	83
7.8.2 Modbus RTU Message Structure	84
7.8.3 Start/Stop Field	84
7.8.4 Address Field	84
7.8.5 Function Field	84
7.8.6 Data Field	84
7.8.7 CRC Check Field	85

7.8.9 How to Control the Frequency Converter	86
7.8.10 Function Codes Supported by Modbus RTU	87
7.8.11 Modbus Exception Codes	87
7.9 How to Access Parameters	87
7.9.1 Parameter Handling	87
7.9.2 Storage of Data	87
7.9.3 IND	87
7.9.4 Text Blocks	87
7.9.5 Conversion Factor	88
7.9.6 Parameter Values	88
7.10 Examples	88
7.10.2 Force/Write Single Coil (05 HEX)	88
7.10.3 Force/Write Multiple Coils (0F HEX)	89
7.10.5 Preset Single Register (06 HEX)	90
7.11 Danfoss FC Control Profile	91
7.11.1 Control Word According to FC Profile (8-10 Protocol = FC profile)	91
<b>8 General Specifications and Troubleshooting</b>	<b>95</b>
8.1 Mains Supply Tables	95
8.1.1 Mains Supply 3x200-240 V AC	95
8.1.2 Mains Supply 3x380-480 V AC	96
8.1.3 Mains Supply 3x380-480 V AC	98
8.1.4 Mains Supply 3x525-600 V AC	100
8.2 General Specifications	101
8.3 Acoustic Noise	103
8.4 dU/Dt	104
8.5 Derating according to Ambient Temperature and Switching Frequency	106
<b>Index</b>	<b>112</b>

# 1 How to Read this Design Guide

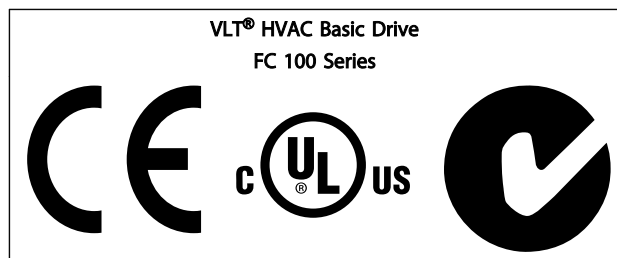

Table 1.1

IP54 enclosure frequency converter do not have UL approvals. This guide can be used with all VLT HVAC Basic Drive frequency converters with software version 2.0X. The actual software version number can be read from *15-43 Software Version*.

Table 1.2

## 1.1.1 Legal Information

This publication contains information proprietary to Danfoss. By accepting and using this manual the user agrees that the information contained herein is used solely for operating equipment from Danfoss or equipment from other vendors if such equipment is intended for communication with Danfoss equipment over a serial communication link. This publication is protected under the Copyright laws of Denmark and most other countries.

Danfoss does not warrant that a software program produced according to the guidelines provided in this manual functions properly in every physical, hardware or software environment.

Although Danfoss has tested and reviewed the documentation within this manual, Danfoss makes no warranty or representation, neither expressed nor implied, with respect to this documentation, including its quality, performance, or fitness for a particular purpose.

In no event shall Danfoss be liable for direct, indirect, special, incidental, or consequential damages arising out of the use, or the inability to use information contained in

this manual, even if advised of the possibility of such damages. In particular, Danfoss is not responsible for any costs, including but not limited to those incurred as a result of lost profits or revenue, loss or damage of equipment, loss of computer programs, loss of data, the costs to substitute these, or any claims by third parties.

Danfoss reserves the right to revise this publication at any time and to make changes to its contents without prior notice or any obligation to notify former or present users of such revisions or changes.

## 1.1.2 Available Literature for VLT® HVAC Basic Drive

- *Quick Guide, MG18A*
- *Programming Guide, MG18B* provides information on how to programme and includes complete parameter descriptions.
- *Design Guide, MG18C* entails all technical information about the frequency converter and customer design and applications.
- *PC-based Configuration Tool MCT 10, MG10R* enables the user to configure the frequency converter from a Windows™ based PC environment.
- Danfoss VLT® Energy Box software at [www.danfoss.com/BusinessAreas/DrivesSolutions](http://www.danfoss.com/BusinessAreas/DrivesSolutions) then choose PC Software Download VLT® Energy Box Software allows energy consumption comparisons of HVAC fans and pumps driven by Danfoss drives and alternative methods of flow control. This tool may be used to project, as accurately as possible, the costs, savings, and payback of using Danfoss frequency converters on HVAC fans and pumps.

Danfoss technical literature is available in print from your local Danfoss Sales Office or at:  
[www.danfoss.com/BusinessAreas/DrivesSolutions/Documentations/Technical+Documentation.htm](http://www.danfoss.com/BusinessAreas/DrivesSolutions/Documentations/Technical+Documentation.htm)

### 1.1.3 Symbols

The following symbols are used in this manual.

#### **⚠ WARNING**

Indicates a potentially hazardous situation which, if not avoided, could result in death or serious injury.

#### **⚠ CAUTION**

Indicates a potentially hazardous situation which, if not avoided, may result in minor or moderate injury. It may also be used to alert against unsafe practices.

#### **CAUTION**

Indicates a situation that may result in equipment or property-damage-only accidents.

#### **NOTE**

Indicates highlighted information that should be regarded with attention to avoid mistakes or operate equipment at less than optimal performance.

### 1.1.4 Abbreviations

Alternating current	AC
American wire gauge	AWG
Ampere/AMP	A
Automatic Motor Adaptation	AMA
Current limit	$I_{LIM}$
Degrees Celsius	°C
Direct current	DC
Electro Magnetic Compatibility	EMC
Electronic Thermal Relay	ETR
Frequency Converter	FC
Gram	g
Hertz	Hz
Kilohertz	kHz
Local Control Panel	LCP
Meter	m
Millihenry Inductance	mH
Milliamper	mA
Millisecond	ms
Minute	min
Motion Control Tool	MCT
Nanofarad	nF
Newton Meters	Nm
Nominal motor current	$I_{M,N}$
Nominal motor frequency	$f_{M,N}$
Nominal motor power	$P_{M,N}$
Nominal motor voltage	$U_{M,N}$
Protective Extra Low Voltage	PELV
Printed Circuit Board	PCB
Rated Inverter Output Current	$I_{INV}$
Revolutions Per Minute	RPM
Regenerative terminals	Regen
Second	s
Synchronous Motor Speed	$n_s$
Torque limit	$T_{LIM}$
Volts	V
The maximum output current	$I_{VLT,MAX}$
The rated output current supplied by the frequency converter	$I_{VLT,N}$

**Table 1.3**

### 1.1.5 Definitions

#### Frequency Converter

$I_{VLT,MAX}$

The maximum output current.

$I_{VLT,N}$

The rated output current supplied by the frequency converter.

$U_{VLT, MAX}$

The maximum output voltage.

#### Input

Control command	Group	
The connected motor can start and stop with LCP and the digital inputs. Functions are divided into 2 groups. Functions in group 1 have higher priority than functions in group 2.	1	Reset, Coasting stop, Reset and Coasting stop, Quick-stop, DC braking, Stop and the [Off] key.
	2	Start, Pulse start, Reversing, Start reversing, Jog and Freeze output

Table 1.4

#### Motor

$f_{JOG}$

The motor frequency when the jog function is activated (via digital terminals).

$f_M$

The motor frequency.

$f_{MAX}$

The maximum motor frequency.

$f_{MIN}$

The minimum motor frequency.

$f_{M,N}$

The rated motor frequency (nameplate data).

$I_M$

The motor current.

$I_{M,N}$

The rated motor current (nameplate data).

$n_{M,N}$

The rated motor speed (nameplate data).

$P_{M,N}$

The rated motor power (nameplate data).

$U_M$

The instantaneous motor voltage.

$U_{M,N}$

The rated motor voltage (nameplate data).

#### Break-away torque

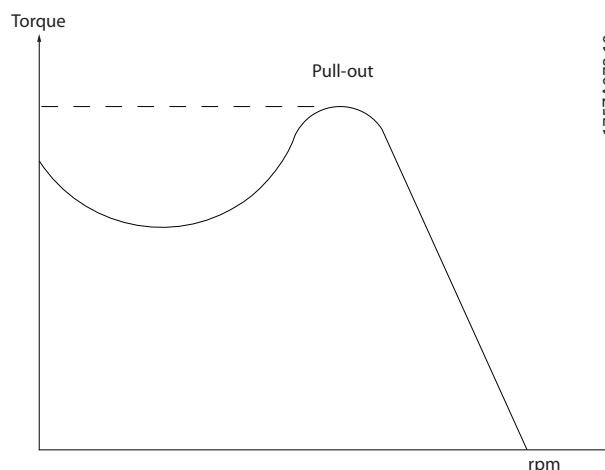

175ZA078.10

Illustration 1.1

$\eta_{VLT}$

The efficiency of the LCP is defined as the ratio between the power output and the power input.

#### Start-disable command

A stop command belonging to the group 1 control commands - see this group.

#### Stop command

See Control commands.

#### References

##### Analog Reference

A signal transmitted to the analog inputs 53 or 54, can be voltage or current.

##### Bus Reference

A signal transmitted to the serial communication port (FC port).

##### Preset Reference

A defined preset reference to be set from -100% to +100% of the reference range. Selection of eight preset references via the digital terminals.

Ref<sub>MAX</sub>

Determines the relationship between the reference input at 100% full scale value (typically 10 V, 20 mA) and the resulting reference. The maximum reference value set in 3-03 *Maximum Reference*.

Ref<sub>MIN</sub>

Determines the relationship between the reference input at 0% value (typically 0 V, 0 mA, 4 mA) and the resulting reference. The minimum reference value set in 3-02 *Minimum Reference*

**Miscellaneous**Analog Inputs

The analog inputs are used for controlling various functions of the frequency converter.

There are two types of analog inputs:

Current input, 0-20 mA and 4-20 mA

Voltage input, 0-10 V DC.

Analog Outputs

The analog outputs can supply a signal of 0-20 mA, 4-20 mA, or a digital signal.

Automatic Motor Adaptation, AMA

AMA algorithm determines the electrical parameters for the connected motor at standstill.

Digital Inputs

The digital inputs can be used for controlling various functions of the frequency converter.

Digital Outputs

The frequency converter features 2 Solid State outputs that can supply a 24 V DC (max. 40 mA) signal.

Relay Outputs

The frequency converter features two programmable Relay Outputs.

ETR

Electronic Thermal Relay is a thermal load calculation based on present load and time. Its purpose is to estimate the motor temperature.

Initialising

If initialising is carried out (*14-22 Operation Mode*), the programmable parameters of the frequency converter return to their default settings.

Initialising; *14-22 Operation Mode* will not initialise communication parameters.

Intermittent Duty Cycle

An intermittent duty rating refers to a sequence of duty cycles. Each cycle consists of an on-load and an off-load period. The operation can be either periodic duty or non-periodic duty.

LCP

The Local Control Panel (LCP) makes up a complete interface for control and programming of the frequency converter. The control panel is detachable and can be

installed up to 3 m from the frequency converter, i.e. in a front panel by means of the installation kit option.

lsb

Least significant bit.

MCM

Short for Mille Circular Mil, an American measuring unit for cable cross-section. 1 MCM  $\equiv$  0.5067 mm<sup>2</sup>.

msb

Most significant bit.

On-line/Off-line Parameters

Changes to on-line parameters are activated immediately after the data value is changed. Press [OK] to activate off-line parameters.

PI Controller

The PI controller maintains the desired speed, pressure, temperature, etc. by adjusting the output frequency to match the varying load.

RCD

Residual Current Device.

Set-up

Parameter settings in 2 Set-ups can be saved. Change between the 2 parameter Set-ups and edit one Set-up, while another Set-up is active.

Slip Compensation

The frequency converter compensates for the motor slip by giving the frequency a supplement that follows the measured motor load keeping the motor speed almost constant.

Smart Logic Control (SLC)

The SLC is a sequence of user defined actions executed when the associated user defined events are evaluated as true by the SLC.

Thermistor

A temperature-dependent resistor placed where the temperature is to be monitored (frequency converter or motor).

Trip

A state entered in fault situations, e.g. if the frequency converter is subject to an over-temperature or when the frequency converter is protecting the motor, process or mechanism. Restart is prevented until the cause of the fault has disappeared and the trip state is cancelled by activating reset or, in some cases, by being programmed to reset automatically. Trip may not be used for personal safety.

Trip Locked

A state entered in fault situations when the frequency converter is protecting itself and requiring physical intervention, for example, if the frequency converter is subject to a short circuit on the output. A locked trip can only be cancelled by cutting off mains, removing the cause of the fault, and reconnecting the frequency converter. Restart is prevented until the trip state is cancelled by



activating reset or, in some cases, by being programmed to reset automatically. Trip locked may not be used for personal safety.

#### VT Characteristics

Variable torque characteristics used for pumps and fans.

#### VV<sup>plus</sup>

If compared with standard voltage/frequency ratio control, Voltage Vector Control (VVC<sup>plus</sup>) improves the dynamics and the stability, both when the speed reference is changed and in relation to the load torque.

### 1.1.6 Power Factor

The power factor is the relation between  $I_1$  and  $I_{RMS}$ .

$$\text{Power factor} = \frac{\sqrt{3} \times U \times I_1 \times \cos\varphi}{\sqrt{3} \times U \times I_{RMS}}$$

The power factor for 3-phase control:

$$= \frac{I_1 \times \cos\varphi}{I_{RMS}} = \frac{I_1}{I_{RMS}} \text{ since } \cos\varphi = 1$$

The power factor indicates to which extent the frequency converter imposes a load on the mains supply.

The lower the power factor, the higher the  $I_{RMS}$  for the same kW performance.

$$I_{RMS} = \sqrt{I_1^2 + I_5^2 + I_7^2 + \dots + I_n^2}$$

In addition, a high power factor indicates that the different harmonic currents are low.

The frequency converters built-in DC coils produce a high power factor, which minimizes the imposed load on the mains supply.

## 2 Introduction to VLT® HVAC Basic Drive

### 2.1 Safety

#### 2.1.1 Safety Note

#### **⚠ WARNING**

##### **DANGEROUS VOLTAGE**

The voltage of the frequency converter is dangerous whenever connected to mains. Incorrect installation of the motor, frequency converter or fieldbus may cause death, serious personal injury or damage to the equipment. Consequently, the instructions in this manual, as well as national and local rules and safety regulations, must be complied with.

##### **Safety Regulations**

1. The frequency converter must be disconnected from mains if repair work is to be carried out. Check that the mains supply has been disconnected and that the necessary time has passed before removing motor and mains plugs.
2. The [Off/Reset] key on the LCP does not disconnect the equipment from mains and is thus not to be used as a safety switch.
3. Correct protective earthing of the equipment must be established, the user must be protected against supply voltage, and the motor must be protected against overload in accordance with applicable national and local regulations.
4. The earth leakage currents are higher than 3.5 mA.
5. Protection against motor overload is set by *1-90 Motor Thermal Protection*. If this function is desired, set *1-90 Motor Thermal Protection* to data value [ETR trip] (default value) or data value [ETR warning]. Note: The function is initialized at 1.16 x rated motor current and rated motor frequency. For the North American market: The ETR functions provide class 20 motor overload protection in accordance with NEC.
6. Do not remove the plugs for the motor and mains supply while the frequency converter is connected to mains. Check that the mains supply has been disconnected and that the necessary time has passed before removing motor and mains plugs.
7. Check that all voltage inputs have been disconnected and that the necessary time has passed before commencing repair work.

##### **Installation at high altitudes**

#### **⚠ CAUTION**

At altitudes above 2 km, contact Danfoss regarding PELV.

#### **⚠ WARNING**

##### **UNINTENDED START**

1. The motor can be brought to a stop with digital commands, bus commands, references or a local stop, while the frequency converter is connected to mains. If personal safety considerations make it necessary to ensure that no unintended start occurs, these stop functions are not sufficient.
2. While parameters are being changed, the motor may start. Consequently, the stop key [Off/Reset] must always be activated; following which data can be modified.
3. A motor that has been stopped may start if faults occur in the electronics of the frequency converter, or if a temporary overload or a fault in the supply mains or the motor connection ceases.

#### 2.1.2 Safety

#### **⚠ WARNING**

##### **HIGH VOLTAGE!**

Frequency converters contain high voltage when connected to AC mains input power. Installation, start up, and maintenance should be performed by qualified personnel only. Failure to perform installation, start up, and maintenance by qualified personnel could result in death or serious injury.

##### **High Voltage**

Frequency converters are connected to hazardous mains voltages. Extreme care should be taken to protect against shock. Only trained personnel familiar with electronic equipment should install, start, or maintain this equipment.

## ⚠ WARNING

### UNINTENDED START!

When the frequency converter is connected to AC mains, the motor may start at any time. The frequency converter, motor, and any driven equipment must be in operational readiness. Failure to be in operational readiness when the frequency converter is connected to AC mains could result in death, serious injury, equipment, or property damage.

#### Unintended Start

When the frequency converter is connected to the AC mains, the motor may be started by means of an external switch, a serial bus command, an input reference signal, or a cleared fault condition. Use appropriate cautions to guard against an unintended start.

## ⚠ WARNING

### DISCHARGE TIME!

Frequency converters contain DC-link capacitors that can remain charged even when the frequency converter is not powered. To avoid electrical hazards, disconnect AC mains, any permanent magnet type motors, and any remote DC-link power supplies, including battery backups, UPS and DC-link connections to other frequency converters. Wait for the capacitors to fully discharge before performing any service or repair work. The amount of wait time is listed in the *Discharge Time* table. Failure to wait the specified time after power has been removed before doing service or repair could result in death or serious injury.

Voltage [V]	Power range [kW]	Minimum waiting time [min]
3x200	0.25–3.7	4
3x200	5.5–45	15
3x400	0.37–7.5	4
3x400	11–90	15
3x600	2.2–7.5	4
3x600	11–90	15

Table 2.1 Discharge Time

### 2.1.3 Disposal Instruction

	<p>Equipment containing electrical components may not be disposed of together with domestic waste. It must be separately collected with electrical and electronic waste according to local and currently valid legislation.</p>
--	---

Table 2.2

## 2.2 CE Labeling

### 2.2.1 CE Conformity and Labeling

#### What is CE Conformity and Labeling?

The purpose of CE labeling is to avoid technical trade obstacles within EFTA and the EU. The EU has introduced the CE label as a simple way of showing whether a product complies with the relevant EU directives. The CE label says nothing about the specifications or quality of the product. Frequency converters are regulated by three EU directives:

#### The machinery directive (98/37/EEC)

All machines with critical moving parts are covered by the machinery directive of January 1, 1995. Since a frequency converter is largely electrical, it does not fall under the machinery directive. However, if a frequency converter is supplied for use in a machine, we provide information on safety aspects relating to the frequency converter. We do this by means of a manufacturer's declaration.

#### The low-voltage directive (73/23/EEC)

Frequency converters must be CE labeled in accordance with the low-voltage directive of January 1, 1997. The directive applies to all electrical equipment and appliances used in the 50-1000 V AC and the 75-1500 V DC voltage ranges. Danfoss CE-labels in accordance with the directive and issues a declaration of conformity upon request.

#### The EMC directive (89/336/EEC)

EMC is short for electromagnetic compatibility. The presence of electromagnetic compatibility means that the mutual interference between different components/appliances does not affect the way the appliances work. The EMC directive came into effect January 1, 1996. Danfoss CE-labels in accordance with the directive and issues a declaration of conformity upon request. To carry out EMC-correct installation, see the instructions in this Design Guide. In addition, we specify which standards our products comply with. We offer the filters presented in the specifications and provide other types of assistance to ensure the optimum EMC result.

The frequency converter is most often used by professionals of the trade as a complex component forming part of a larger appliance, system or installation. It must be noted that the responsibility for the final EMC properties of the appliance, system or installation rests with the installer.

### 2.2.2 What is Covered

The EU "Guidelines on the Application of Council Directive 89/336/EEC" outline three typical situations of using a frequency converter. See 2.2.3 *Frequency Converter and CE Labeling* for EMC coverage and CE labeling.

1. The frequency converter is sold directly to the end-consumer. The frequency converter is for example sold to a DIY market. The end-consumer is a layman. He installs the frequency converter himself for use with a hobby machine, a kitchen appliance, etc. For such applications, the frequency converter must be CE labeled in accordance with the EMC directive.
2. The frequency converter is sold for installation in a plant. The plant is built up by professionals of the trade. It could be a production plant or a heating/ventilation plant designed and installed by professionals of the trade. Neither the frequency converter nor the finished plant has to be CE labeled under the EMC directive. However, the unit must comply with the basic EMC requirements of the directive. This is ensured by using components, appliances, and systems that are CE labeled under the EMC directive.
3. The frequency converter is sold as part of a complete system. The system is being marketed as complete and could for example, be an air-conditioning system. The complete system must be CE labeled in accordance with the EMC directive. The manufacturer can ensure CE labeling under the EMC directive either by using CE labeled components or by testing the EMC of the system. If only CE labeled components are chosen, the entire system does not have to be tested.

### 2.2.3 Danfoss Frequency Converter and CE Labeling

CE labeling is a positive feature when used for its original purpose, that is, to facilitate trade within the EU and EFTA.

However, CE labeling may cover many different specifications. Check what a given CE label specifically covers.

The covered specifications can be very different and a CE label may therefore give the installer a false feeling of security when using a frequency converter as a component in a system or an appliance.

Danfoss CE labels the frequency converters in accordance with the low-voltage directive. This means that if the frequency converter is installed correctly, we guarantee compliance with the low-voltage directive. Danfoss issues a declaration of conformity that confirms our CE labeling in accordance with the low-voltage directive.

The CE label also applies to the EMC directive provided that the instructions for EMC-correct installation and

filtering are followed. On this basis, a declaration of conformity in accordance with the EMC directive is issued.

The Design Guide offers detailed instructions for installation to ensure EMC-correct installation. Furthermore, Danfoss specifies which our different products comply with.

Danfoss provides other types of assistance that can help to obtain the best EMC result.

### 2.2.4 Compliance with EMC Directive 89/336/EEC

As mentioned, the frequency converter is mostly used by professionals of the trade as a complex component forming part of a larger appliance, system, or installation. It must be noted that the responsibility for the final EMC properties of the appliance, system or installation rests with the installer. As an aid to the installer, Danfoss has prepared EMC installation guidelines for the Power Drive system. The standards and test levels stated for Power Drive systems are complied with, if the EMC-correct instructions for installation are followed.

## 2.3 Air humidity

The frequency converter has been designed to meet the IEC/EN 60068-2-3 standard, EN 50178 9.4.2.2 at 50 °C.

## 2.4 Aggressive Environments

A frequency converter contains many mechanical and electronic components. All are to some extent vulnerable to environmental effects.

### **CAUTION**

**The frequency converter should not be installed in environments with airborne liquids, particles, or gases capable of affecting and damaging the electronic components. Failure to take the necessary protective measures increases the risk of stoppages, thus reducing the life of the frequency converter.**

Liquids can be carried through the air and condense in the frequency converter and may cause corrosion of components and metal parts. Steam, oil, and salt water may cause corrosion of components and metal parts. In such environments, use equipment with enclosure rating IP54. As an extra protection, coated printed circuit boards can be ordered as an option. (Standard on some power sizes.)

Airborne Particles such as dust may cause mechanical, electrical, or thermal failure in the frequency converter. A typical indicator of excessive levels of airborne particles is dust particles around the frequency converter fan. In dusty environments, use equipment with enclosure rating IP54 or a cabinet for IP20/TYPE 1 equipment.

In environments with high temperatures and humidity, corrosive gases such as sulphur, nitrogen, and chlorine compounds causes chemical processes on the frequency converter components.

Such chemical reactions rapidly affects and damages the electronic components. In such environments, mount the equipment in a cabinet with fresh air ventilation, keeping aggressive gases away from the frequency converter. An extra protection in such areas is a coating of the printed circuit boards, which can be ordered as an option.

**NOTE**

**Mounting frequency converters in aggressive environments increases the risk of stoppages and considerably reduces the life of the frequency converter.**

Before installing the frequency converter, check the ambient air for liquids, particles, and gases. This is done by observing existing installations in this environment. Typical indicators of harmful airborne liquids are water or oil on metal parts, or corrosion of metal parts.

Excessive dust particle levels are often found on installation cabinets and existing electrical installations. One indicator of aggressive airborne gases is blackening of copper rails and cable ends on existing installations.

**2.5 Vibration and Shock**

The frequency converter has been tested according to the procedure based on the shown standards:

The frequency converter complies with requirements that exist for units mounted on the walls and floors of production premises, as well as in panels bolted to walls or floors.

IEC/EN 60068-2-6	Vibration (sinusoidal) - 1970
IEC/EN 60068-2-64	Vibration, broad-band random

Table 2.3

**2.6 Advantages**

**2.6.1 Why use a Frequency Converter for Controlling Fans and Pumps?**

A frequency converter takes advantage of the fact that centrifugal fans and pumps follow the laws of proportionality for such fans and pumps. For further information see 2.6.3 *Example of Energy Savings*.

**2.6.2 The Clear Advantage - Energy Savings**

The clear advantage of using a frequency converter for controlling the speed of fans or pumps lies in the electricity savings.

When comparing with alternative control systems and technologies, a frequency converter is the optimum energy control system for controlling fan and pump systems.

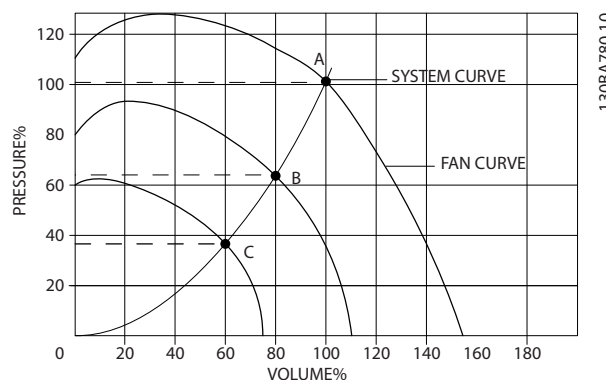
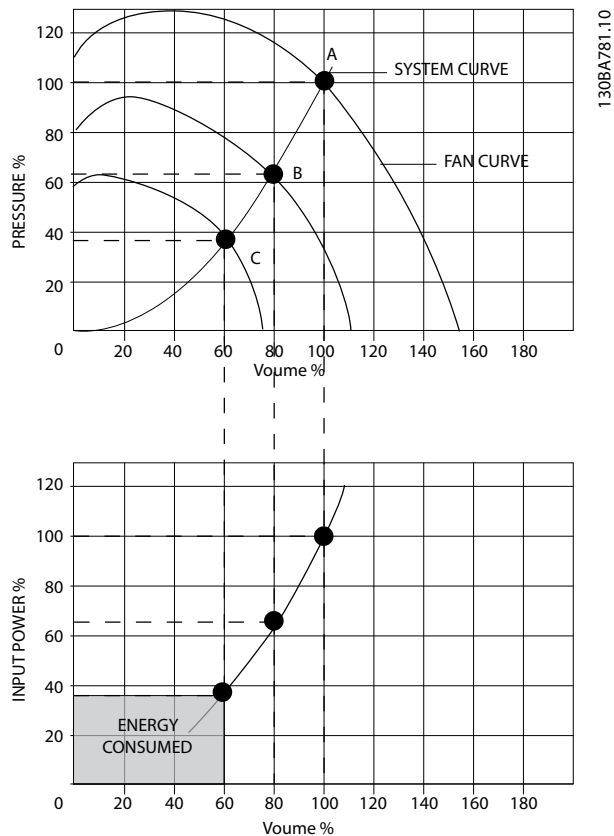

Illustration 2.1 The graph is showing fan curves (A, B, and C) for reduced fan volumes.



**Illustration 2.2** When using a frequency converter to reduce fan capacity to 60% - more than 50% energy savings may be obtained in typical applications.

### 2.6.3 Example of Energy Savings

As shown in *Illustration 2.3*, the flow is controlled by changing the RPM. By reducing the speed only 20% from the rated speed, the flow is also reduced by 20%. This is because the flow is directly proportional to the RPM. The consumption of electricity, however, is reduced by 50%. If the system in question only needs to be able to supply a flow that corresponds to 100% a few days in a year, while the average is below 80% of the rated flow for the remainder of the year, the amount of energy saved is even more than 50%.

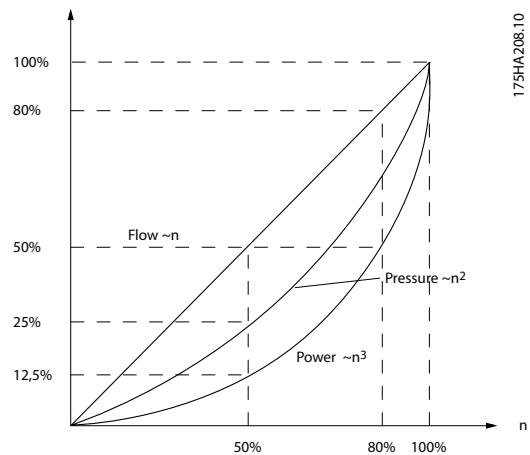

**Illustration 2.3** Laws of Proportionality

$$\text{Flow : } \frac{Q_1}{Q_2} = \frac{n_1}{n_2}$$

$$\text{Pressure : } \frac{H_1}{H_2} = \left(\frac{n_1}{n_2}\right)^2$$

$$\text{Power : } \frac{P_1}{P_2} = \left(\frac{n_1}{n_2}\right)^3$$

### 2.6.4 Comparison of Energy Savings

The Danfoss frequency converter solution offers major savings compared with traditional energy saving solutions. This is because the frequency converter is able to control fan speed according to thermal load on the system and the fact that the frequency converter has a built-in facility that enables the frequency converter to function as a Building Management System, BMS.

*Illustration 2.5* shows typical energy savings obtainable with 3 well-known solutions when fan volume is reduced to i.e. 60%. As the graph shows, more than 50% energy savings can be achieved in typical applications.

*Illustration 2.3* describes the dependence of flow, pressure and power consumption on RPM.

Q=Flow	P=Power
Q <sub>1</sub> =Rated flow	P <sub>1</sub> =Rated power
Q <sub>2</sub> =Reduced flow	P <sub>2</sub> =Reduced power
H=Pressure	n=Speed regulation
H <sub>1</sub> =Rated pressure	n <sub>1</sub> =Rated speed
H <sub>2</sub> =Reduced pressure	n <sub>2</sub> =Reduced speed

**Table 2.4** The Laws of Proportionality

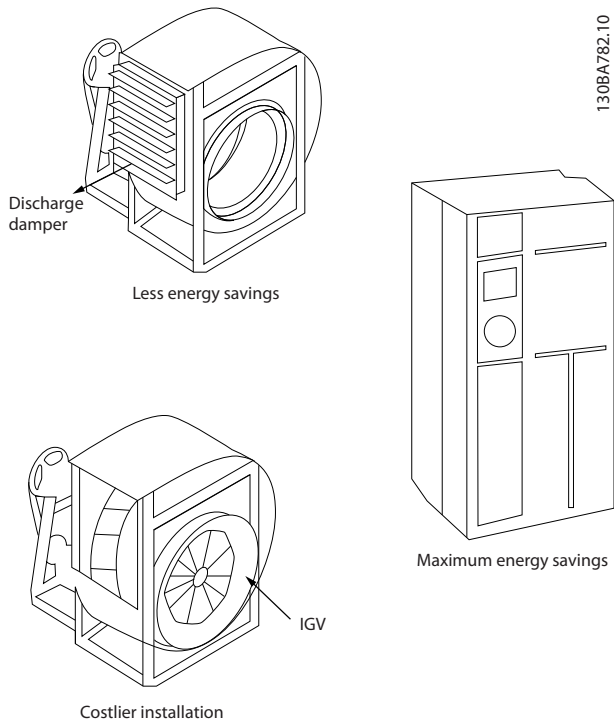

Illustration 2.4 The Three Common Energy Saving Systems

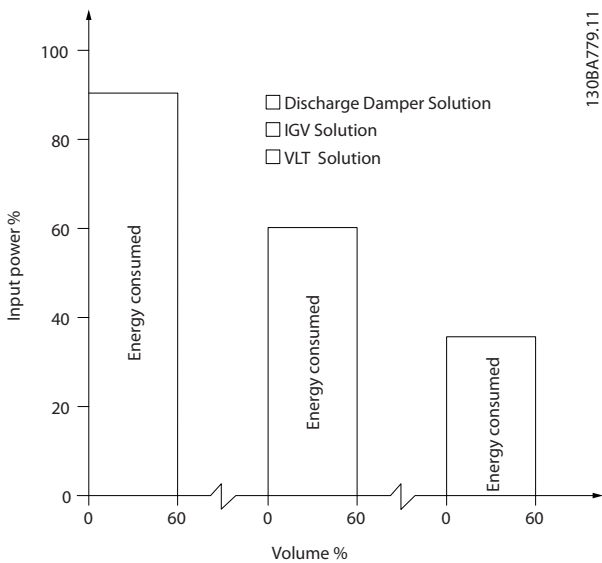

Illustration 2.5 Energy Savings

Discharge dampers reduce power consumption somewhat. Inlet Guide Vans offer a 40% reduction but are expensive to install. The Danfoss frequency converter solution reduces energy consumption with more than 50% and is easy to install.

### 2.6.5 Example with Varying Flow over 1 Year

This example is calculated based on pump characteristics obtained from a pump datasheet. The result obtained shows energy savings in excess of 50% at the given flow distribution over a year. The pay back period depends on the price per kWh and price of frequency converter. In this example it is less than a year when compared with valves and constant speed.

#### Energy savings

$$P_{\text{shaft}} = P_{\text{shaft output}}$$

Flow distribution over 1 year

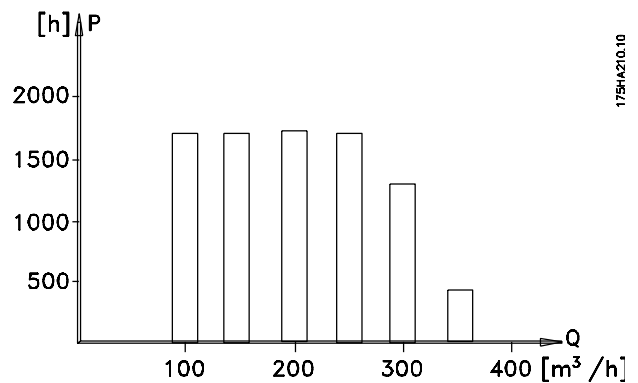

Illustration 2.6

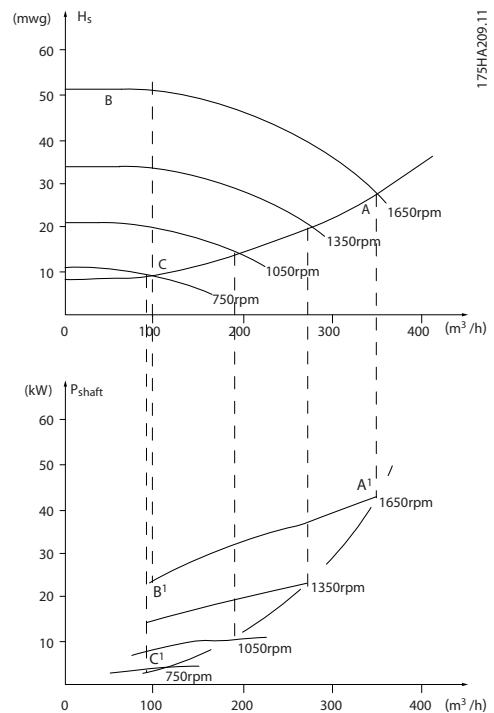

Illustration 2.7

m <sup>3</sup> / h	Distribution		Valve regulation		Frequency Converter control	
	%	Hours	Power	Consumption	Power	Consumption
			A <sub>1</sub> - B <sub>1</sub>	kWh	A <sub>1</sub> - C <sub>1</sub>	kWh
350	5	438	42.5	18.615	42.5	18.615
300	15	1314	38.5	50.589	29.0	38.106
250	20	1752	35.0	61.320	18.5	32.412
200	20	1752	31.5	55.188	11.5	20.148
150	20	1752	28.0	49.056	6.5	11.388
100	20	1752	23.0	40.296	3.5	6.132
<b>Σ</b>	100	8760		275.064		26.801

Table 2.5

### 2.6.6 Better Control

If a frequency converter is used for controlling the flow or pressure of a system, improved control is obtained. A frequency converter can vary the speed of the fan or pump, obtaining variable control of flow and pressure. Furthermore, a frequency converter can quickly adapt the speed of the fan or pump to new flow or pressure conditions in the system. Simple control of process (Flow, Level or Pressure) utilizing the built-in PI control.

### 2.6.7 Star/Delta Starter or Soft-starter not Required

When larger motors are started, it is necessary in many countries to use equipment that limits the start-up current. In more traditional systems, a star/delta starter or soft-starter is widely used. Such motor starters are not required if a frequency converter is used.

As illustrated in *Illustration 2.8*, a frequency converter does not consume more than rated current.

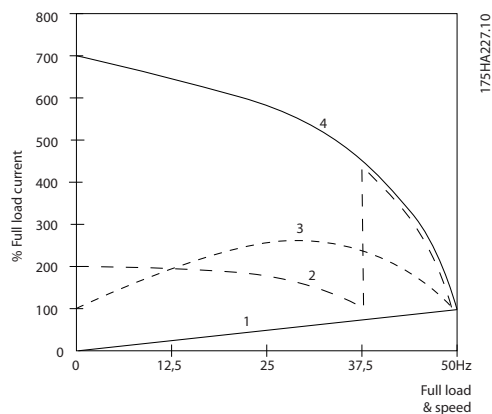

Illustration 2.8 Start-up Current

1	VLT® HVAC Basic Drive
2	Star/delta starter
3	Soft-starter
4	Start directly on mains

Table 2.6

### 2.6.8 Using a Frequency Converter Saves Money

Example 2.6.9 *Without a Frequency Converter* shows that a lot of equipment is not required when a frequency converter is used. It is possible to calculate the cost of installing the two different systems. In the example on the following page, the two systems can be established at roughly the same price.



2.6.9 Without a Frequency Converter

2

D.D.C.=Direct Digital Control	E.M.S.=Energy Management system
V.A.V.=Variable Air Volume	
Sensor P=Pressure	Sensor T=Temperature

Table 2.7 Fan System made in the Traditional Way

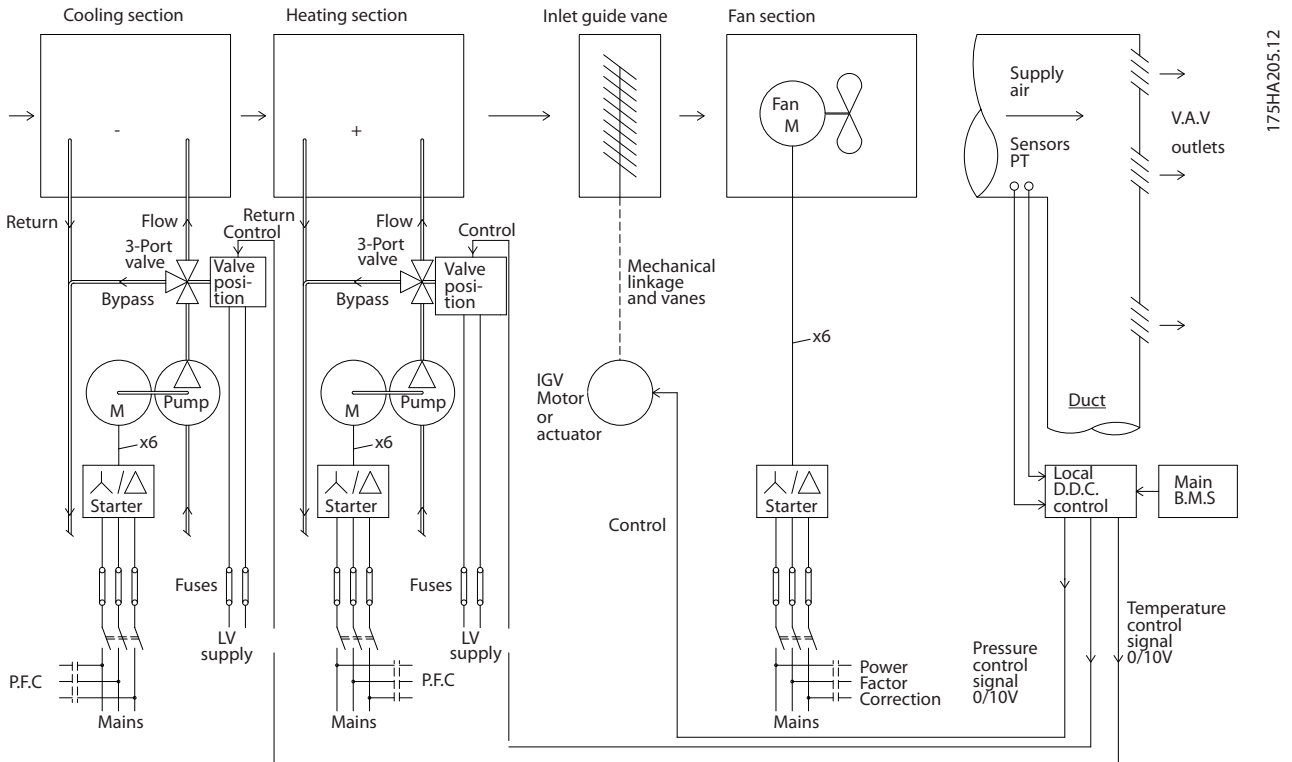

Illustration 2.9

2.6.10 With a Frequency Converter

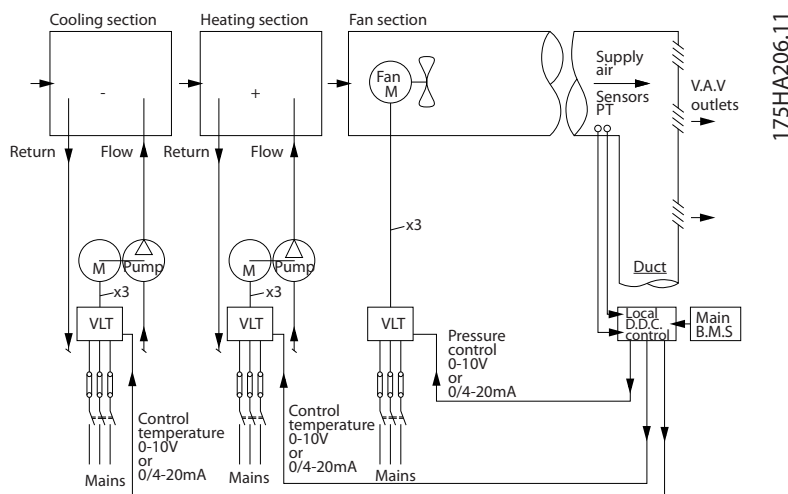

Illustration 2.10 Fan System Controlled by Frequency Converters

## 2.6.11 Application Examples

The next few pages provide typical examples of applications within HVAC.

For further information about a given application, ask the Danfoss supplier for an information sheet that gives a full description of the application. The following application notes can be downloaded from the Danfoss web page, [www.danfoss.com/BusinessAreas/DrivesSolutions/Documentations/Technical+Documentation.htm](http://www.danfoss.com/BusinessAreas/DrivesSolutions/Documentations/Technical+Documentation.htm)

### **Variable Air Volume**

Ask for *The Drive to...Improving Variable Air Volume Ventilation Systems, MN60A.*

### **Constant Air Volume**

Ask for *The Drive to...Improving Constant Air Volume Ventilation Systems, MN60B.*

### **Cooling Tower Fan**

Ask for *The Drive to...Improving fan control on cooling towers, MN60C.*

### **Condenser pumps**

Ask for *The Drive to...Improving condenser water pumping systems, MN60F.*

### **Primary pumps**

Ask for *The Drive to...Improve your primary pumping in primary/secondary pumping systems, MN60D.*

### **Secondary pumps**

Ask for *The Drive to...Improve your secondary pumping in primary/secondary pumping systems, MN60E.*

2

2.6.12 Variable Air Volume

VAV or Variable Air Volume systems, control both the ventilation and temperature to satisfy the requirements of a building. Central VAV systems are considered to be the most energy efficient method to air condition buildings. By designing central systems instead of distributed systems, a greater efficiency can be obtained. The efficiency comes from utilizing larger fans and larger chillers which have much higher efficiencies than small motors and distributed air-cooled chillers. Savings are also seen from the decreased maintenance requirements.

the installation. Instead of creating an artificial pressure drop or causing a decrease in fan efficiency, the frequency converter decreases the speed of the fan to provide the flow and pressure required by the system. Centrifugal devices such as fans behave according to the centrifugal laws. This means the fans decrease the pressure and flow they produce as their speed is reduced. Their power consumption is thereby significantly reduced. The PI controller of the VLT® HVAC Basic Drive can be used to eliminate the need for additional controllers.

2.6.13 The VLT Solution

While dampers and IGVs work to maintain a constant pressure in the ductwork, a frequency converter solution saves much more energy and reduces the complexity of

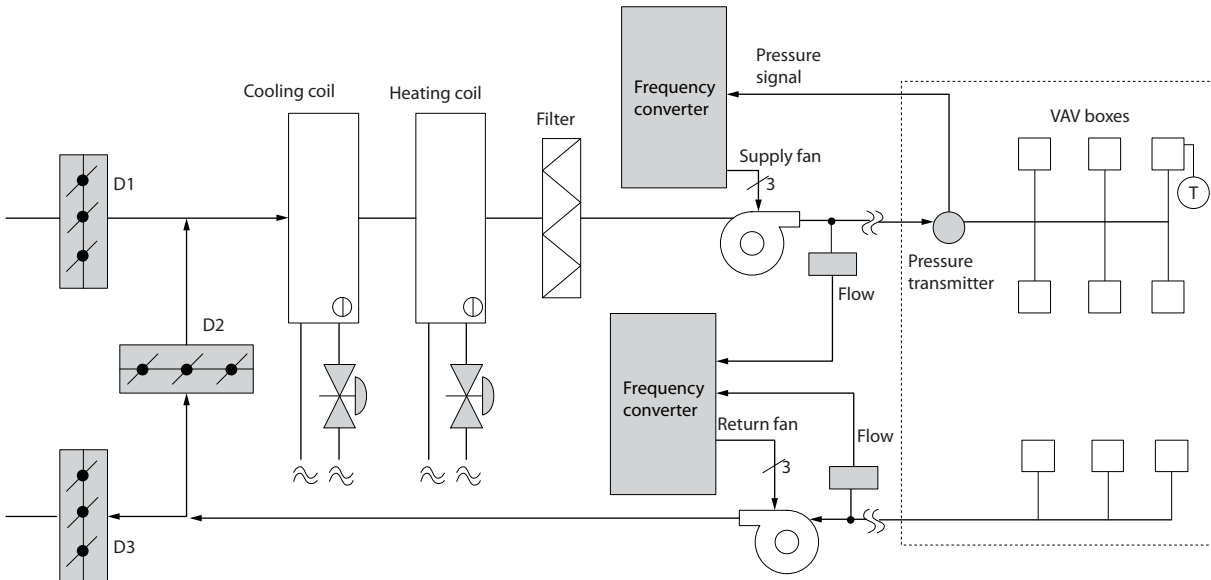

Illustration 2.11

130BB45.10

### 2.6.14 Constant Air Volume

CAV, or Constant Air Volume systems, are central ventilation systems usually used to supply large common zones with the minimum amounts of fresh tempered air. They preceded VAV systems and are therefore found in older multi-zoned commercial buildings as well. These systems preheat amounts of fresh air utilizing Air Handling Units (AHUs) with a heating coil, and many are also used to air condition buildings and have a cooling coil. Fan coil units are frequently used to assist in the heating and cooling requirements in the individual zones.

### 2.6.15 The VLT Solution

With a frequency converter, significant energy savings can be obtained while maintaining decent control of the building. Temperature sensors or CO<sub>2</sub> sensors can be used as feedback signals to frequency converters. Whether controlling temperature, air quality, or both, a CAV system can be controlled to operate based on actual building conditions. As the number of people in the controlled area decreases, the need for fresh air decreases. The CO<sub>2</sub> sensor detects lower levels and decreases the supply fans speed. The return fan modulates to maintain a static pressure setpoint or fixed difference between the supply and return ducts as well.

With temperature control, especially used in air conditioning systems, as the outside temperature varies as well as the number of people in the controlled zone changes, different cooling requirements exist. As the temperature decreases below the set-point, the supply fan can decrease its speed. The return fan modulates to maintain a static pressure set-point. By decreasing the air flow, energy used to heat or cool the fresh air is also reduced, adding further savings.

Several features of the Danfoss HVAC dedicated frequency converter can be utilized to improve the performance of your CAV system. One concern of controlling a ventilation system is poor air quality. The programmable minimum frequency can be set to maintain a minimum amount of supply air regardless of the feedback or reference signal. The frequency converter also includes one PI controller, which allows monitoring both temperature and air quality. Even if the temperature requirement is satisfied, the frequency converter maintains enough supply air to satisfy the air quality sensor. The controller is capable of monitoring and comparing two feedback signals to control the return fan by maintaining a fixed differential air flow between the supply and return ducts as well.

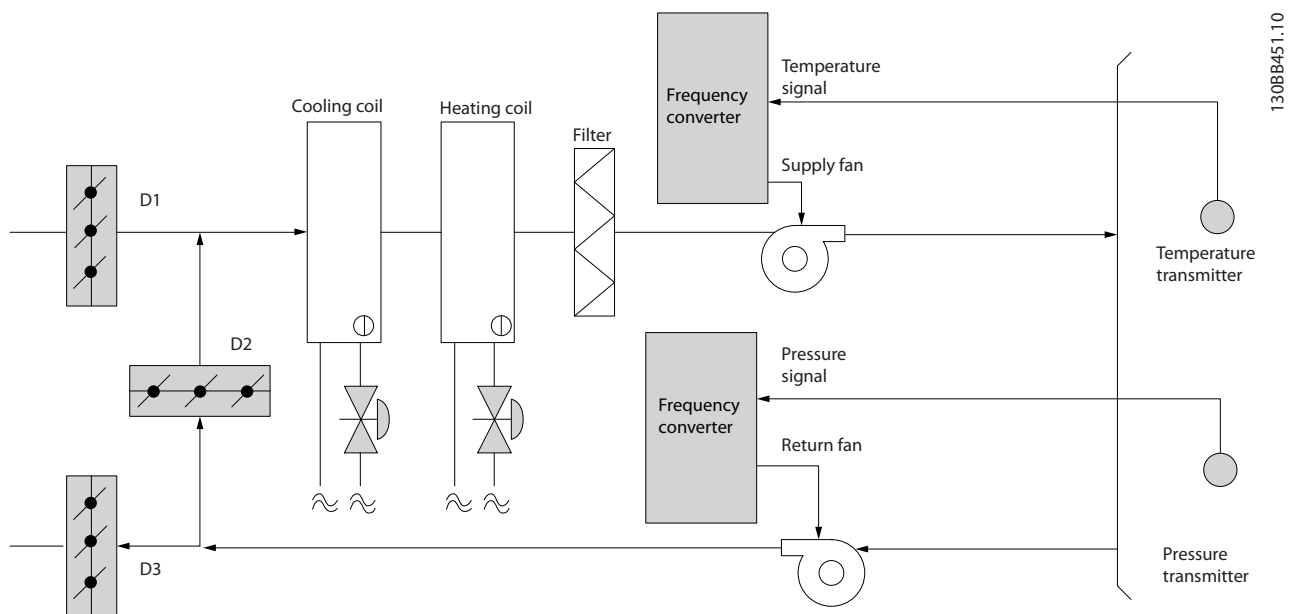

Illustration 2.12

2

2.6.16 Cooling Tower Fan

Cooling Tower Fans cool condenser water in water cooled chiller systems. Water cooled chillers provide the most efficient means of creating chilled water. They are as much as 20% more efficient than air cooled chillers. Depending on climate, cooling towers are often the most energy efficient method of cooling the condenser water from chillers.

They cool the condenser water by evaporation. The condenser water is sprayed into the cooling tower onto the cooling towers “fill” to increase its surface area. The tower fan blows air through the fill and sprayed water to aid in the evaporation. Evaporation removes energy from the water dropping its temperature. The cooled water collects in the cooling towers basin where it is pumped back into the chillers condenser and the cycle is repeated.

2.6.17 The VLT Solution

With a frequency converter, the cooling towers fans can be controlled to the required speed to maintain the condenser water temperature. The frequency converters can also be used to turn the fan on and off as needed.

Several features of the Danfoss HVAC dedicated frequency converter, the HVAC frequency converter can be utilized to improve the performance of your cooling tower fans application. As the cooling tower fans drop below a certain speed, the effect the fan has on cooling the water becomes small. Also, when utilizing a gear-box to frequency control the tower fan, a minimum speed of 40-50% may be required.

The customer programmable minimum frequency setting is available to maintain this minimum frequency even as the feedback or speed reference calls for lower speeds.

Also as a standard feature, the frequency converter can be programmed to enter a “sleep” mode and stop the fan until a higher speed is required. Additionally, some cooling tower fans have undesirable frequencies that may cause vibrations. These frequencies can easily be avoided by programming the bypass frequency ranges in the frequency converter.

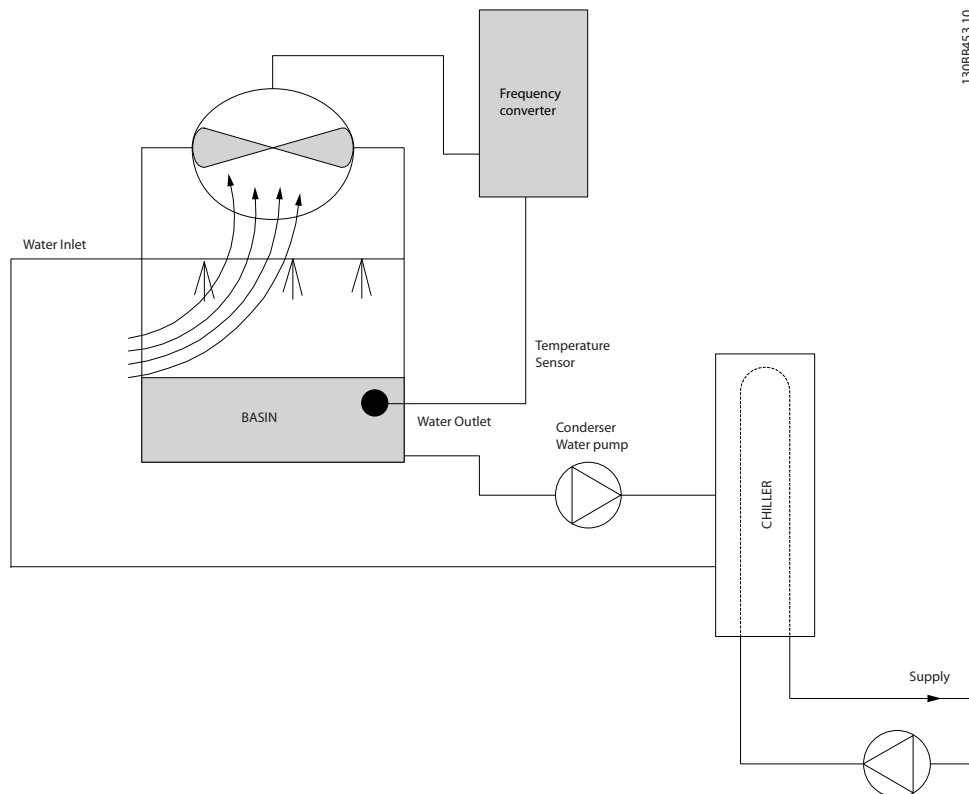

130BB45.3.10

Illustration 2.13

### 2.6.18 Condenser Pumps

Condenser water pumps are primarily used to circulate water through the condenser section of water cooled chillers and their associated cooling tower. The condenser water absorbs the heat from the chiller's condenser section and releases it into the atmosphere in the cooling tower. These systems are used to provide the most efficient means of creating chilled water, they are as much as 20% more efficient than air cooled chillers.

Using a frequency converter instead of a throttling valve simply saves the energy that would have been absorbed by the valve. This can amount to savings of 15-20% or more. Trimming the is irreversible, thus if the conditions change and higher flow is required the impeller must be replaced.

### 2.6.19 The VLT Solution

Frequency converters can be added to condenser water pumps instead of balancing the pumps with a throttling valve or trimming the pump impeller.

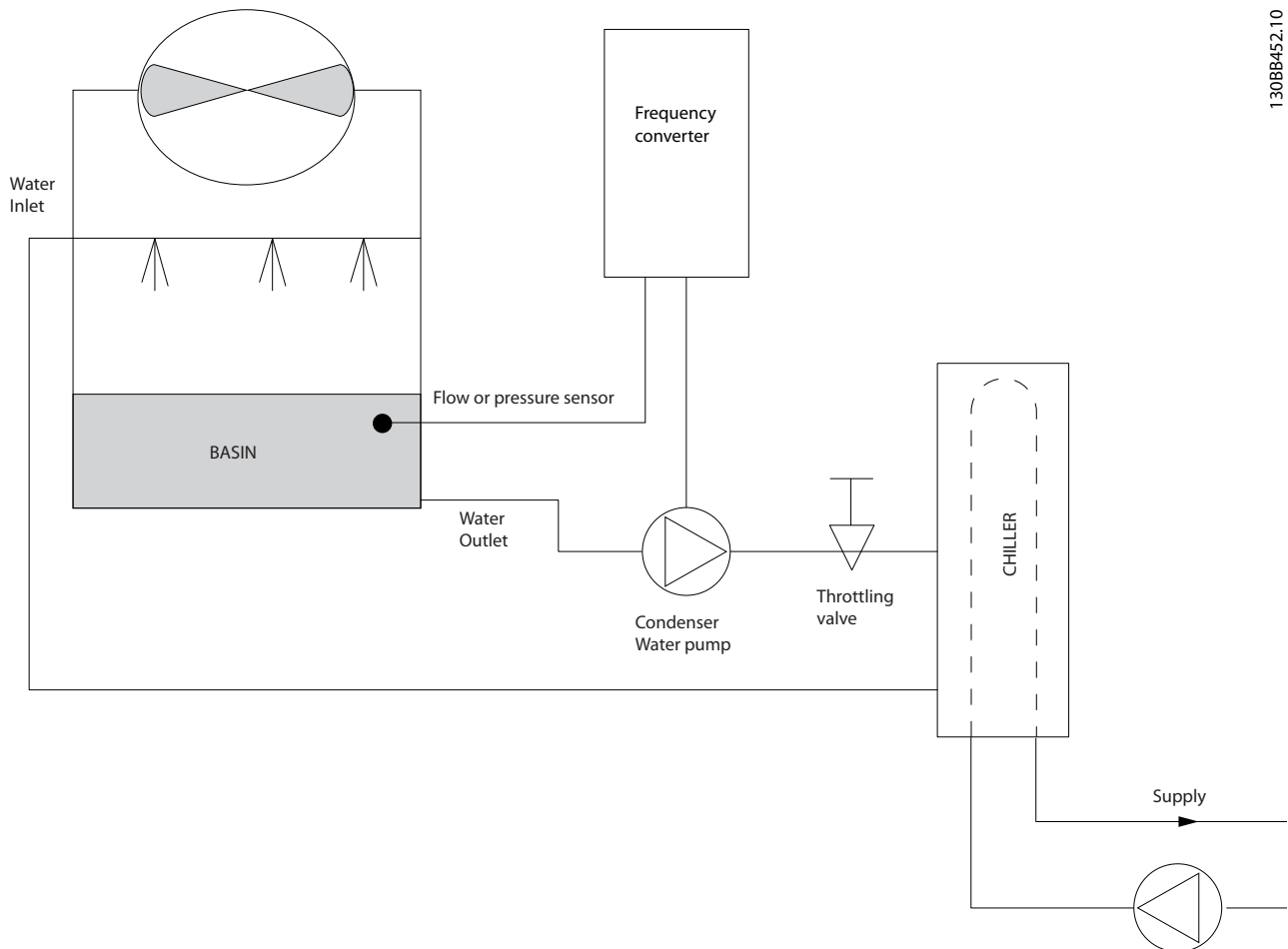

130BB452.10

Illustration 2.14

2

### 2.6.20 Primary Pumps

Primary pumps in a primary/secondary pumping system can be used to maintain a constant flow through devices that encounter operation or control difficulties when exposed to variable flow. The primary/secondary pumping technique decouples the “primary” production loop from the “secondary” distribution loop. This allows devices such as chillers to obtain constant design flow and operate properly while allowing the rest of the system to vary in flow.

As the evaporator flow rate decreases in a chiller, the chilled water begins to become over-chilled. As this happens, the chiller attempts to decrease its cooling capacity. If the flow rate drops far enough, or too quickly, the chiller cannot shed its load sufficiently and the chiller’s safety trips the chiller requiring a manual reset. This situation is common in large installations especially when two or more chillers in parallel are installed if primary/secondary pumping is not utilized.

#### 2.6.21 The VLT Solution

Depending on the size of the system and the size of the primary loop, the energy consumption of the primary loop can become substantial.

A frequency converter can be added to the primary system, to replace the throttling valve and/or trimming of the impellers, leading to reduced operating expenses. Two control methods are common:

The first method uses a flow meter. Because the desired flow rate is known and is constant, a flow meter installed at the discharge of each chiller, can be used to control the pump directly. Using the built-in PI controller, the frequency converter always maintains the appropriate flow rate, even compensating for the changing resistance in the primary piping loop as chillers and their pumps are staged on and off.

The other method is local speed determination. The operator simply decreases the output frequency until the design flow rate is achieved.

Using a frequency converter to decrease the pump speed is very similar to trimming the pump impeller, except it does not require any labor and the pump efficiency remains higher. The balancing contractor simply decreases the speed of the pump until the proper flow rate is achieved and leaves the speed fixed. The pump operates at this speed any time the chiller is staged on. Because the primary loop does not have control valves or other devices that can cause the system curve to change and the variance due to staging pumps and chillers on and off is usually small, this fixed speed remains appropriate. In the event the flow rate needs to be increased later in the systems life, the frequency converter can simply increase the pump speed instead of requiring a new pump impeller.

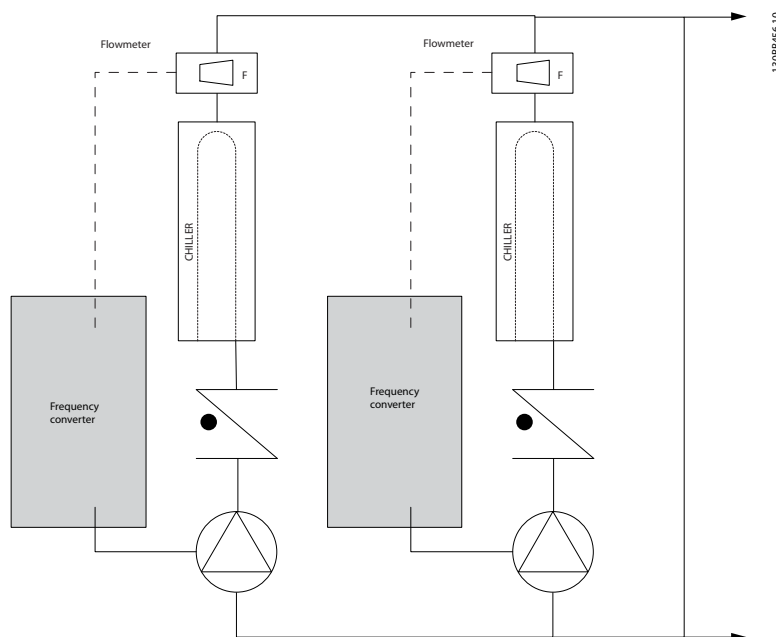

Illustration 2.15

### 2.6.22 Secondary Pumps

Secondary pumps in a primary/secondary chilled water pumping system distribute the chilled water to the loads from the primary production loop. The primary/secondary pumping system is used to hydraulically de-couple one piping loop from another. In this case, the primary pump is used to maintain a constant flow through the chillers while allowing the secondary pumps to vary in flow, increase control and save energy.

If the primary/secondary design concept is not used and a variable volume system is designed, when the flow rate drops far enough or too quickly, the chiller cannot shed its load properly. The chiller's low evaporator temperature safety then trips the chiller requiring a manual reset. This situation is common in large installations especially when two or more chillers in parallel are installed.

### 2.6.23 The VLT Solution

While the primary-secondary system with two-way valves improves energy savings and eases system control problems, the true energy savings and control potential is realized by adding frequency converters.

With the proper sensor location, the addition of frequency converters allows the pumps to vary their speed to follow the system curve instead of the pump curve.

This results in the elimination of wasted energy and eliminates most of the over-pressurization, two-way valves can be subjected to.

As the monitored loads are reached, the two-way valves close down. This increases the differential pressure measured across the load and two-way valve. As this differential pressure starts to rise, the pump is slowed to maintain the control head also called setpoint value. This set-point value is calculated by summing the pressure drop of the load and two way valve together under design conditions.

#### NOTE

**When running multiple pumps in parallel, they must run at the same speed to maximize energy savings, either with individual dedicated drives or one frequency converter running multiple pumps in parallel.**

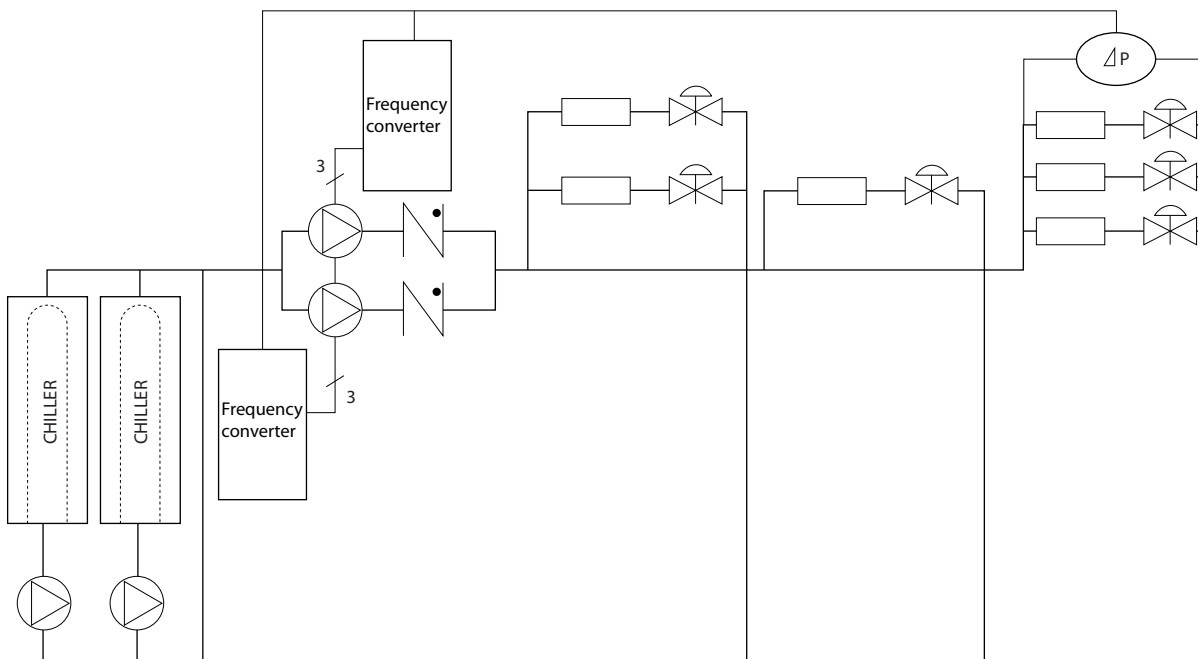

130BB454.10

Illustration 2.16



## 2.7 Control Structures

1-00 Configuration Mode can be selected if open or closed loop is to be used.

### 2.7.1 Control Structure Open Loop

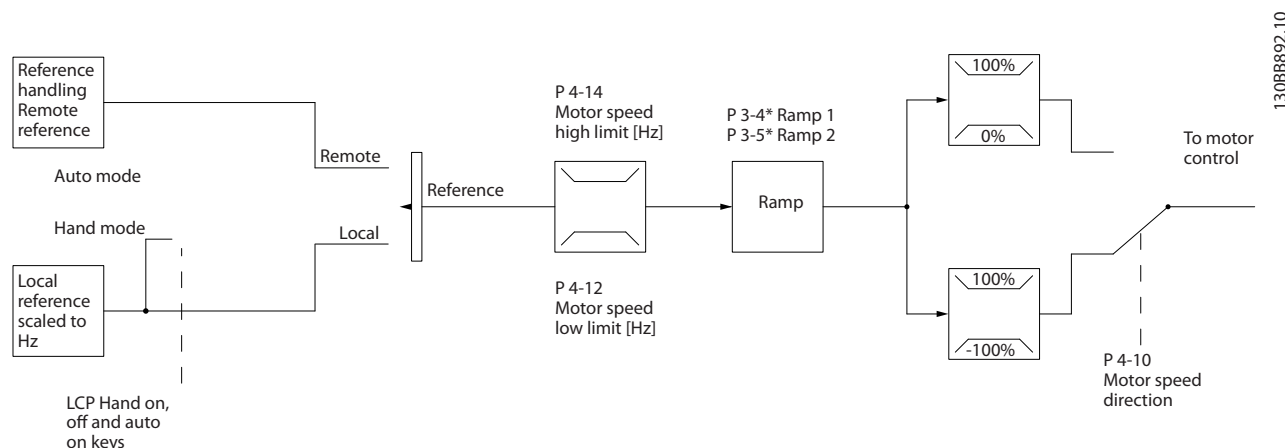

**Illustration 2.17 Open Loop Structure**

In the configuration shown in *Illustration 2.17*, 1-00 Configuration Mode is set to [0] Open loop. The resulting reference from the reference handling system or the local reference is received and fed through the ramp limitation and speed limitation before being sent to the motor control. The output from the motor control is then limited by the maximum frequency limit.

### 2.7.2 PM/EC+ Motor Control

The Danfoss EC+ concept provides the possibility for using high efficient PM motors in IEC standard frame size operated by Danfoss frequency converters. The commissioning procedure is comparable to the existing one for asynchronous (induction) motors by utilising the Danfoss VVC<sup>plus</sup> PM control strategy.

Customer advantages:

- Free choice of motor technology (permanent magnet or induction motor)
- Installation and operation as known on induction motors
- Manufacturer independent when choosing system components (e.g. motors)
- Best system efficiency by choosing best components
- Possible retrofit of existing installations
- Power range: 0.37-90 kW (400 V) for induction motors and 0.37-22 kW (400 V) for PM motors.

Current limitations:

- Currently only supported up to 22 kW
- Currently limited to non salient type PM motors
- LC filters not supported together with PM motors
- Over Voltage Control algorithm is not supported with PM motors
- Kinetic backup algorithm is not supported with PM motors
- Support reduced AMA of the stator resistance  $R_s$  in the system only
- No stall detection
- No ETR function

### 2.7.3 Local (Hand On) and Remote (Auto On) Control

The frequency converter can be operated manually via the local control panel (LCP) or remotely via analog/digital inputs or serial bus. If allowed in 0-40 [Hand on] Key on LCP, 0-44 [Off/Reset] Key on LCP, and 0-42 [Auto on] Key on LCP, it is possible to start and stop the frequency converter by LCP using the [Hand On] and [Off/Reset] keys. Alarms can be reset via the [Off/Reset] key.

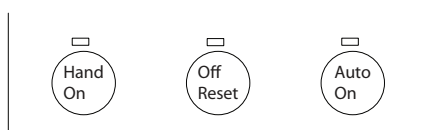

Illustration 2.18

Local reference forces the configuration mode to open loop, independent on the setting of 1-00 Configuration Mode.

Local Reference is restored at power-down.

### 2.7.4 Control Structure Closed Loop

The internal controller allows the frequency converter to become an integral part of the controlled system. The frequency converter receives a feedback signal from a

130BB893.10

sensor in the system. It then compares this feedback to a set-point reference value and determines the error, if any, between these two signals. It then adjusts the speed of the motor to correct this error.

For example, consider a pump application where the speed of a pump is to be controlled so that the static pressure in a pipe is constant. The desired static pressure value is supplied to the frequency converter as the set-point reference. A static pressure sensor measures the actual static pressure in the pipe and supplies this to the frequency converter as a feedback signal. If the feedback signal is greater than the set-point reference, the frequency converter slows down to reduce the pressure. In a similar way, if the pipe pressure is lower than the set-point reference, the frequency converter automatically speed up to increase the pressure provided by the pump.

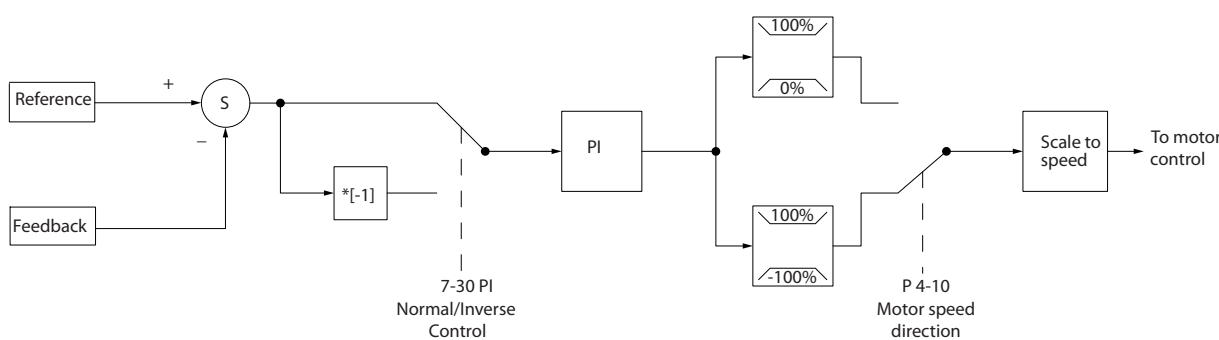

Illustration 2.19

130BB894.11

While the default values for the frequency converter's Closed Loop controller often provides satisfactory performance, the control of the system can often be optimized by adjusting some of the Closed Loop controller's parameters.

### 2.7.5 Feedback Conversion

In some applications it may be useful to convert the feedback signal. One example of this is using a pressure signal to provide flow feedback. Since the square root of pressure is proportional to flow, the square root of the pressure signal yields a value proportional to the flow. See *Illustration 2.20*.

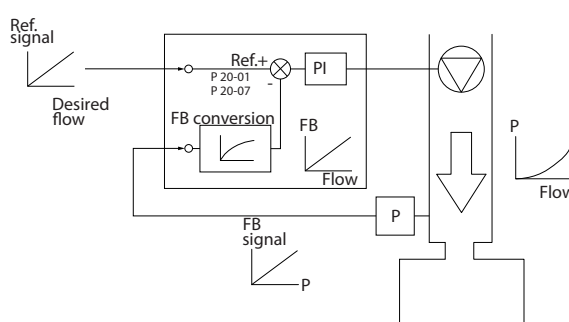

Illustration 2.20

130BB895.10

## 2.7.6 Reference Handling

Details for Open Loop and Closed Loop operation.

2

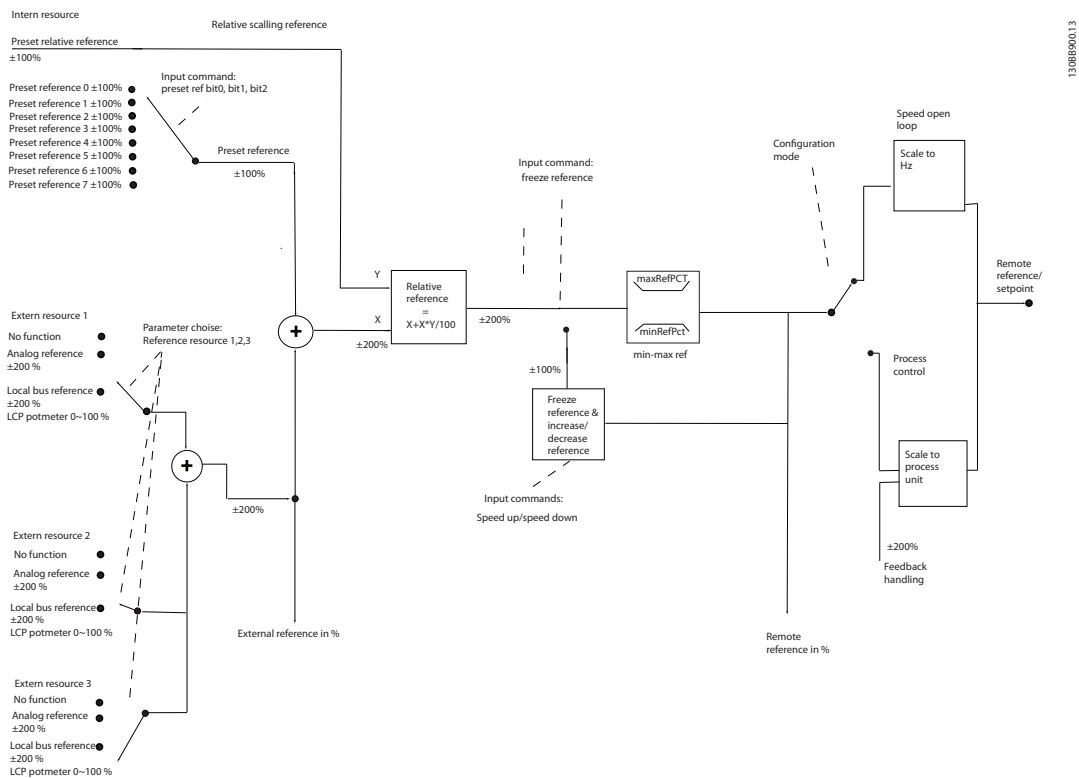

Illustration 2.21 Block Diagram Showing Remote Reference

The remote reference is comprised of

- Preset references
- External references (analog inputs and serial communication bus references)
- The preset relative reference
- Feedback controlled setpoint

Up to 8 preset references can be programmed in the frequency converter. The active preset reference can be selected using digital inputs or the serial communications bus. The reference can also be supplied externally, most commonly from an analog input. This external source is selected by one of the 3 Reference Source parameters (3-15 Reference 1 Source, 3-16 Reference 2 Source and 3-17 Reference 3 Source). All reference resources and the bus reference are added to produce the total external reference. The external reference, the preset reference or the sum of the two can be selected to be the active

reference. Finally, this reference can be scaled using 3-14 Preset Relative Reference.

The scaled reference is calculated as follows:

$$Reference = X + X \times \left(\frac{Y}{100}\right)$$

Where X is the external reference, the preset reference or the sum of these and Y is 3-14 Preset Relative Reference in [%].

If Y, 3-14 Preset Relative Reference is set to 0%, the reference will not be affected by the scaling.

### 2.7.7 Closed Loop Set-up Wizard

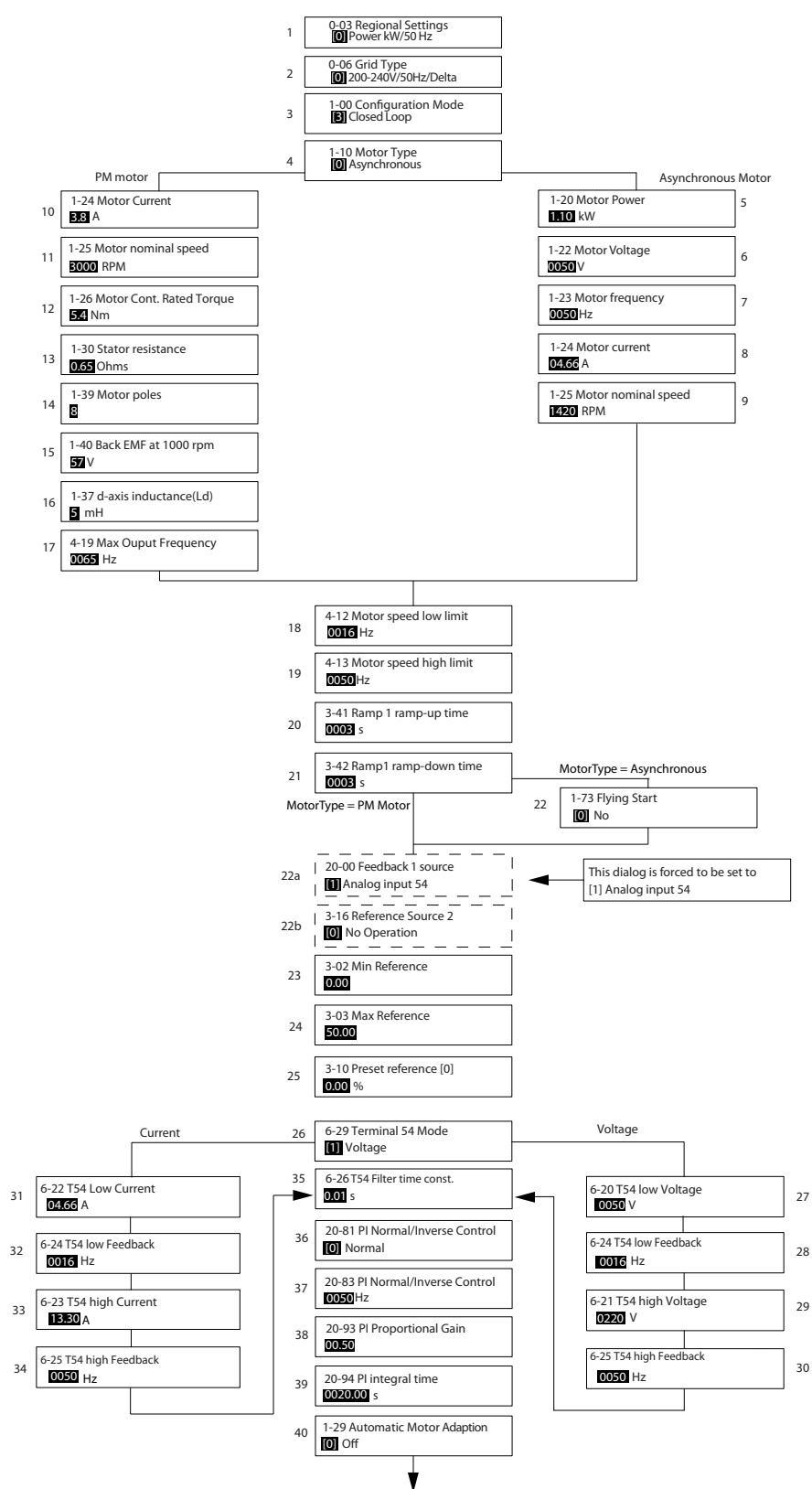

Illustration 2.22

## Closed Loop Set-up Wizard

No & Name	Range	Default	Function
0-03 Regional Settings	[0] International [1] US	0	
0-06 GridType	[0] -[[132] see start -up wizard for open loop application	Size selected	Select operating mode for restart upon reconnection of the frequency converter to mains voltage after power down
1-00 Configuration Mode	[0] Open loop [3] Closed loop	0	Change this parameter to Closed loop
1-10 Motor Construction	*[0] Motor construction [1] PM, non salient SPM	[0] Asynchron	Setting the parameter value might change these parameters: 1-01 Motor Control Principle 1-03 Torque Characteristics 1-14 Damping Gain 1-15 Low Speed Filter Time Const 1-16 High Speed Filter Time Const 1-17 Voltage filter time const 1-20 Motor Power 1-22 Motor Voltage 1-23 Motor Frequency 1-25 Motor Nominal Speed 1-26 Motor Cont. Rated Torque 1-30 Stator Resistance (Rs) 1-33 Stator Leakage Reactance (X1) 1-35 Main Reactance (Xh) 1-37 d-axis Inductance (Ld) 1-39 Motor Poles 1-40 Back EMF at 1000 RPM 1-66 Min. Current at Low Speed 1-72 Start Function 1-73 Flying Start 4-19 Max Output Frequency 4-58 Missing Motor Phase Function
1-20 Motor Power	0.09-110 kW	Size related	Enter motor power from nameplate data
1-22 Motor Voltage	50.0-1000.0 V	Size related	Enter motor voltage from nameplate data
1-23 Motor Frequency	20.0-400.0 Hz	Size related	Enter motor frequency from nameplate data
1-24 Motor Current	0.0 -10000.00 A	Size related	Enter motor current from nameplate data
1-25 Motor Nominal Speed	100.0-9999.0 RPM	Size related	Enter motor nominal speed from nameplate data
1-26 Motor Cont. Rated Torque	0.1-1000.0	Size related	This parameter is available only when 1-10 Motor Construction Design is set to [1] PM, non-salient SPM. <b>NOTE</b> Changing this parameter affects settings of other parameters
1-29 Automatic Motor Adaption (AMA)		Off	Performing an AMA optimizes motor performance
1-30 Stator Resistance (Rs)	0.000-99.990	Size related	Set the stator resistance value
1-37 d-axis Inductance (Ld)	0-1000	Size related	Enter the value of the d-axis inductance. Obtain the value from the permanent magnet motor data sheet. The de-axis inductance cannot be found by performing an AMA.
1-39 Motor Poles	2-100	4	Enter the number of motor poles
1-40 Back EMF at 1000 RPM	10-9000	Size related	Line-Line RMS back EMF voltage at 1000 RPM

No & Name	Range	Default	Function
1-73 Flying Start	[0] Disabled [1] Enabled	0	Select [1] <i>Enable</i> to enable the frequency converter to catch a spinning motor. I.e. fan applications. When PM is selected, Flying Start is enabled.
3-02 Minimum Reference	-4999-4999	0	The minimum reference is the lowest value obtainable by summing all references
3-03 Maximum Reference	-4999-4999	50	The maximum reference is the highest value obtainable by summing all references
3-10 Preset Reference	-100-100%	0	Enter the set point
3-41 Ramp 1 Ramp Up Time	0.05-3600.0 s	Size related	Ramp up time from 0 to rated 1-23 <i>Motor Frequency</i> if Asynchron motor is selected; ramp up time from 0 to 1-25 <i>Motor Nominal Speed</i> if PM motor is selected"
3-42 Ramp 1 Ramp Down Time	0.05-3600.0 s	Size related	Ramp down time from rated 1-23 <i>Motor Frequency</i> to 0 if Asynchron motor is selected; ramp down time from 1-25 <i>Motor Nominal Speed</i> to 0 if PM motor is selected
4-12 Motor Speed Low Limit [Hz]	0.0-400 Hz	0.0 Hz	Enter the minimum limit for low speed
4-14 Motor Speed High Limit [Hz]	0-400 Hz	65 Hz	Enter the minimum limit for high speed
4-19 Max Output Frequency	0-400	Size related	Enter the maximum output frequency value
6-20 Terminal 54 Low Voltage	0-10 V	0.07 V	Enter the voltage that corresponds to the low reference value
6-21 Terminal 54 High Voltage	0-10 V	10 V	Enter the voltage that corresponds to the low high reference value
6-22 Terminal 54 Low Current	0-20 mA	4	Enter the current that corresponds to the high reference value
6-23 Terminal 54 High Current	0-20 mA	20	Enter the current that corresponds to the high reference value
6-24 Terminal 54 Low Ref./Feedb. Value	-4999-4999	0	Enter the feedback value that corresponds to the voltage or current set in 6-20 <i>Terminal 54 Low Voltage</i> /6-22 <i>Terminal 54 Low Current</i>
6-25 Terminal 54 High Ref./Feedb. Value	-4999-4999	50	Enter the feedback value that corresponds to the voltage or current set in 6-21 <i>Terminal 54 High Voltage</i> /6-23 <i>Terminal 54 High Current</i>
6-26 Terminal 54 Filter Time Constant	0-10 s	0.01	Enter the filter time constant
6-29 Terminal 54 mode	[0] Current [1] Voltage	1	Select if terminal 54 is used for current- or voltage input
20-81 PI Normal/ Inverse Control	[0] Normal [1] Inverse	0	Select [0] <i>Normal</i> to set the process control to increase the output speed when the process error is positive. Select [1] <i>Inverse</i> to reduce the output speed.
20-83 PI Start Speed [Hz]	0-200 Hz	0	Enter the motor speed to be attained as a start signal for commencement of PI control
20-93 PI Proportional Gain	0-10	0.01	Enter the process controller proportional gain. Quick control is obtained at high amplification. However if amplification is too great, the process may become unstable
20-94 PI Integral Time	0.1-999.0 s	999.0 s	Enter the process controller integral time. Obtain quick control through a short integral time, though if the integral time is too short, the process becomes unstable. An excessively long integral time disables the integral action.

Table 2.8

## 2.7.8 Tuning the Drive Closed Loop Controller

Once the frequency converter's closed loop controller has been set up, the performance of the controller should be tested. In many cases, its performance may be acceptable using the default values of *20-93 PI Proportional Gain* and *20-94 PI Integral Time*. However, in some cases it may be helpful to optimize these parameter values to provide faster system response while still controlling speed overshoot.

## 2.7.9 Manual PI Adjustment

1. Start the motor.
2. Set *20-93 PI Proportional Gain* to 0.3 and increase it until the feedback signal begins to oscillate. If necessary, start and stop the frequency converter or make step changes in the set-point reference to attempt to cause oscillation. Next reduce the PI proportional gain until the feedback signal stabilizes. Then reduce the proportional gain by 40-60%.
3. Set *20-94 PI Integral Time* to 20 s and reduce it until the feedback signal begins to oscillate. If necessary, start and stop the frequency converter or make step changes in the set-point reference to attempt to cause oscillation. Next, increase the PI integral time until the feedback signal stabilizes. Then increase of the integral time by 15-50%.

## 2.8 General Aspects of EMC

### 2.8.1 General Aspects of EMC Emissions

Electrical interference is usually conducted at frequencies in the range 150 kHz to 30 MHz. Airborne interference from the frequency converter system in the range 30 MHz to 1 GHz is generated from the inverter, motor cable, and the motor.

As shown in *Illustration 2.23*, capacitive currents in the motor cable coupled with a high  $dU/dt$  from the motor voltage generate leakage currents.

The use of a screened motor cable increases the leakage current (see *Illustration 2.23*) because screened cables have higher capacitance to earth than unscreened cables. If the leakage current is not filtered, it causes greater interference on the mains in the radio frequency range below approximately 5 MHz. Since the leakage current ( $I_1$ )

is carried back to the unit through the screen ( $I_3$ ), there will in principle only be a small electro-magnetic field ( $I_4$ ) from the screened motor cable according to the below figure.

The screen reduces the radiated interference but increases the low-frequency interference on the mains. The motor cable screen must be connected to the frequency converter enclosure as well as on the motor enclosure. This is best done by using integrated screen clamps so as to avoid twisted screen ends (pigtailed). These increase the screen impedance at higher frequencies, which reduces the screen effect and increases the leakage current ( $I_4$ ).

If a screened cable is used for fieldbus, relay, control cable, signal interface and brake, the screen must be mounted on the enclosure at both ends. In some situations, however, it is necessary to break the screen to avoid current loops.

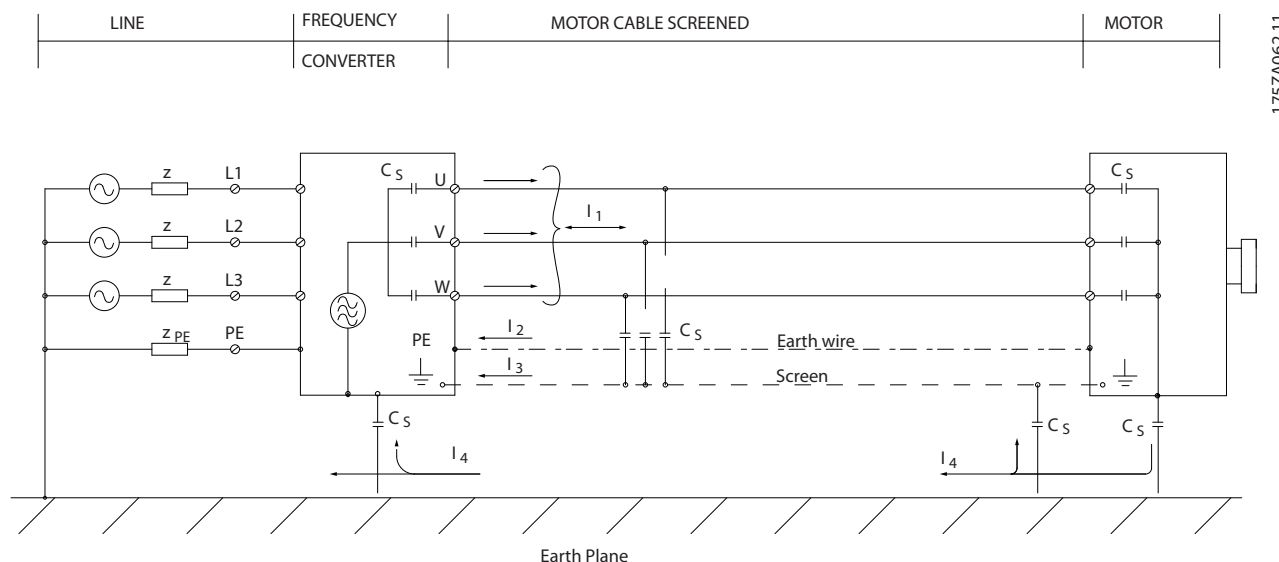

**Illustration 2.23 Situation that Generates Leakage Currents**

If the screen is to be placed on a mounting plate for the frequency converter, the mounting plate must be made of metal, because the screen currents have to be conveyed back to the unit. Moreover, ensure good electrical contact from the mounting plate through the mounting screws to the frequency converter chassis.

When unscreened cables are used, some emission requirements are not complied with, although the immunity requirements are observed.

In order to reduce the interference level from the entire system (unit + installation), make motor and brake cables as short as possible. Avoid placing cables with a sensitive signal level alongside motor and brake cables. Radio interference higher than 50 MHz (airborne) is especially

generated by the control electronics. See 5.2.5 *EMC-Correct Electrical Installation* for more information on EMC.

### 2.8.2 Emission Requirements

According to the EMC product standard for adjustable speed frequency converters EN/IEC 61800-3:2004 the EMC requirements depend on the intended use of the frequency converter. Four categories are defined in the EMC product standard. The definitions of the 4 categories together with the requirements for mains supply voltage conducted emissions are given in *Table 2.9*.



Category	Definition	Conducted emission requirement according to the limits given in EN 55011
C1	Frequency converters installed in the first environment (home and office) with a supply voltage less than 1000 V.	Class B
C2	Frequency converters installed in the first environment (home and office) with a supply voltage less than 1000 V, which are neither plug-in nor movable and are intended to be installed and commissioned by a professional.	Class A Group 1
C3	Frequency converters installed in the second environment (industrial) with a supply voltage lower than 1000 V.	Class A Group 2
C4	Frequency converters installed in the second environment with a supply voltage equal to or above 1000 V or rated current equal to or above 400 A or intended for use in complex systems.	No limit line. An EMC plan should be made.

**Table 2.9 Emission Requirements**

When the generic emission standards are used the frequency converters are required to comply with the following limits

Environment	Generic standard	Conducted emission requirement according to the limits given in EN 55011
First environment (home and office)	EN/IEC 61000-6-3 Emission standard for residential, commercial and light industrial environments.	Class B
Second environment (industrial environment)	EN/IEC 61000-6-4 Emission standard for industrial environments.	Class A Group 1

**Table 2.10**

### 2.8.3 EMC Test Results

The following test results have been obtained using a system with a frequency converter, a screened control cable, a control box with potentiometer, as well as a motor screened cable.

RFI Filter Type	Conduct emission. Maximum shielded cable length [m]						Radiated emission			
	Industrial environment				Housing, trades and light industries		Industrial environment		Housing, trades and light industries	
	EN 55011 Class A2		EN 55011 Class A1		EN 55011 Class B		EN 55011 Class A1		EN 55011 Class B	
	Without external filter	With external filter	Without external filter	With external filter	Without external filter	With external filter	Without external filter	With external filter	Without external filter	With external filter
<b>H4 RFI filter (Class A1)</b>										
0.25-11 kW 3x200-240 V IP20			25	50		20	Yes	Yes		No
0.37-22 kW 3x380-480 V IP20			25	50		20	Yes	Yes		No
<b>H2 RFI filter (Class A2)</b>										
1.5-45 kW 3x200-240 V IP20	25						No		No	
30-90 kW 3x380-480 V IP20	25						No		No	
0.75-18.5 kW 3x380-480 V IP54	25						Yes			
22-90 kW 3x380-480 V IP54	25						No		No	
<b>H3 RFI filter (Class A1/B)</b>										
1.5-45 kW 3x200-240 V IP20			50			20	Yes		No	
30-90 kW 3x380-480 V IP20			50			20	Yes		No	
0.75-18.5 kW 3x380-480 V IP54			25			10	Yes			
22-90 kW 3x380-480 V IP54			50			10	Yes		No	

Table 2.11

## 2.8.4 General Aspects of Harmonics Emission

A frequency converter takes up a non-sinusoidal current from mains, which increases the input current  $I_{RMS}$ . A non-sinusoidal current is transformed by means of a Fourier analysis and split up into sine-wave currents with different frequencies, i.e. different harmonic currents  $I_n$  with 50 Hz as the basic frequency:

Harmonic currents	$I_1$	$I_5$	$I_7$
Hz	50	250	350

Table 2.12

The harmonics do not affect the power consumption directly but increase the heat losses in the installation (transformer, cables). Consequently, in plants with a high percentage of rectifier load, maintain harmonic currents at a low level to avoid overload of the transformer and high temperature in the cables.

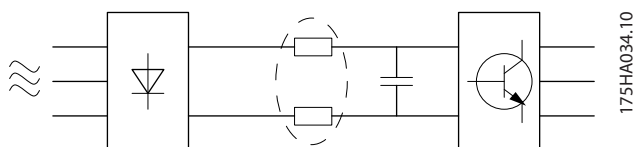

Illustration 2.24

### NOTE

Some of the harmonic currents might disturb communication equipment connected to the same transformer or cause resonance in connection with power-factor correction batteries.

To ensure low harmonic currents, the frequency converter is equipped with intermediate circuit coils as standard. This normally reduces the input current  $I_{RMS}$  by 40%.

The voltage distortion on the mains supply voltage depends on the size of the harmonic currents multiplied by the mains impedance for the frequency in question. The total voltage distortion THD is calculated on the basis of the individual voltage harmonics using this formula:

$$THD \% = \sqrt{U_5^2 + U_7^2 + \dots + U_N^2}$$

( $U_N$  % of  $U$ )

## 2.8.5 Harmonics Emission Requirements

### Equipment connected to the public supply network

Options	Definition
1	IEC/EN 61000-3-2 Class A for 3-phase balanced equipment (for professional equipment only up to 1 kW total power).
2	IEC/EN 61000-3-12 Equipment 16 A-75 A and professional equipment as from 1 kW up to 16 A phase current.

Table 2.13

## 2.8.6 Harmonics Test Results (Emission)

Power sizes up to PK75 in T4 and P3K7 in T2 complies with IEC/EN 61000-3-2 Class A. Power sizes from P1K1 and up to P18K in T2 and up to P90K in T4 complies with IEC/EN 61000-3-12, Table 4.

	Individual Harmonic Current $I_n/I_1$ (%)			
	$I_5$	$I_7$	$I_{11}$	$I_{13}$
Actual 0.25-11 kW, IP20, 200 V (typical)	32.6	16.6	8.0	6.0
Limit for $R_{scc} \geq 120$	40	25	15	10
	Harmonic current distortion factor (%)			
	THD		PWHD	
Actual 0.25-11 kW, 200 V (typical)	39		41.4	
Limit for $R_{scc} \geq 120$	48		46	

Table 2.14

	Individual Harmonic Current $I_n/I_1$ (%)			
	$I_5$	$I_7$	$I_{11}$	$I_{13}$
Actual 0.37-22 kW, IP20, 380-480 V (typical)	36.7	20.8	7.6	6.4
Limit for $R_{scc} \geq 120$	40	25	15	10
	Harmonic current distortion factor (%)			
	THD		PWHD	
Actual 0.37-22 kW, 380-480 V (typical)	44.4		40.8	
Limit for $R_{scc} \geq 120$	48		46	

Table 2.15

	Individual Harmonic Current $I_n/I_1$ (%)			
	$I_5$	$I_7$	$I_{11}$	$I_{13}$
Actual 30-90 kW, IP20, 380-480 V (typical)	36.7	13.8	6.9	4.2
Limit for $R_{scc} \geq 120$	40	25	15	10
	Harmonic current distortion factor (%)			
	THD		PWHd	
Actual 30-90 kW, 380-480 V (typical)	40.6		28.8	
Limit for $R_{scc} \geq 120$	48		46	

Table 2.16

	Individual Harmonic Current $I_n/I_1$ (%)			
	$I_5$	$I_7$	$I_{11}$	$I_{13}$
Actual 0.75-18.5 kW, IP54, 380-480 V (typical)	36.7	20.8	7.6	6.4
Limit for $R_{scc} \geq 120$	40	25	15	10
	Harmonic current distortion factor (%)			
	THD		PWHd	
Actual 0.75-18.5 kW, IP54, 380-480 V (typical)	44.4		40.8	
Limit for $R_{scc} \geq 120$	48		46	

Table 2.20

	Individual Harmonic Current $I_n/I_1$ (%)			
	$I_5$	$I_7$	$I_{11}$	$I_{13}$
Actual 2.2-15 kW, IP20, 525-600 V (typical)	48	25	7	5
	Harmonic current distortion factor (%)			
	THD		PWHd	
Actual 2.2-15 kW, 525-600 V (typical)	55		27	

Table 2.17

	Individual Harmonic Current $I_n/I_1$ (%)			
	$I_5$	$I_7$	$I_{11}$	$I_{13}$
Actual 15-45 kW, IP20, 200 V (typical)	26.7	9.7	7.7	5
Limit for $R_{scc} \geq 120$	40	25	15	10
	Harmonic current distortion factor (%)			
	THD		PWHd	
Actual 15-45 kW, 200 V (typical)	30.3		27.6	
Limit for $R_{scc} \geq 120$	48		46	

Table 2.21

	Individual Harmonic Current $I_n/I_1$ (%)			
	$I_5$	$I_7$	$I_{11}$	$I_{13}$
Actual 18.5-90 kW, IP20, 525-600 V (typical)	48.8	24.7	6.3	5
	Harmonic current distortion factor (%)			
	THD		PWHd	
Actual 18.5-90 kW, 525-600 V (typical)	55.7		25.3	

Table 2.18

	Individual Harmonic Current $I_n/I_1$ (%)			
	$I_5$	$I_7$	$I_{11}$	$I_{13}$
Actual 22-90 kW, IP54, 400 V (typical)	36.3	14	7	4.3
Limit for $R_{scc} \geq 120$	40	25	15	10
	Harmonic current distortion factor (%)			
	THD		PWHd	
Actual 22-90 kW, IP54 400 V (typical)	40.1		27.1	
Limit for $R_{scc} \geq 120$	48		46	

Table 2.19

Provided that the short-circuit power of the supply  $S_{sc}$  is greater than or equal to:

$$S_{SC} = \sqrt{3} \times R_{SCE} \times U_{mains} \times I_{equ} = \sqrt{3} \times 120 \times 400 \times I_{equ}$$

at the interface point between the user's supply and the public system ( $R_{scc}$ ).

It is the responsibility of the installer or user of the equipment to ensure, by consultation with the distribution network operator if necessary, that the equipment is connected only to a supply with a short-circuit power  $S_{sc}$  greater than or equal to specified above.

Other power sizes can be connected to the public supply network by consultation with the distribution network operator.

Compliance with various system level guidelines:

The harmonic current data in the table are given in accordance with IEC/EN 61000-3-12 with reference to the Power Drive Systems product standard. They may be used as the basis for calculation of the harmonic currents' influence on the power supply system and for the documentation of compliance with relevant regional guidelines: IEEE 519 -1992; G5/4.

### 2.8.7 Immunity Requirements

The immunity requirements for frequency converters depend on the environment where they are installed. The requirements for the industrial environment are higher than the requirements for the home and office environment. All Danfoss frequency converters comply with the requirements for the industrial environment and consequently comply also with the lower requirements for home and office environment with a large safety margin.

### 2.9 Galvanic Isolation (PELV)

#### 2.9.1 PELV - Protective Extra Low Voltage

PELV offers protection by way of extra low voltage. Protection against electric shock is ensured when the electrical supply is of the PELV type and the installation is made as described in local/national regulations on PELV supplies.

All control terminals and relay terminals 01-03/04-06 comply with PELV (Protective Extra Low Voltage) (Does not apply to grounded Delta leg above 440 V).

Galvanic (ensured) isolation is obtained by fulfilling requirements for higher isolation and by providing the relevant creepage/clearance distances. These requirements are described in the EN 61800-5-1 standard.

The components that make up the electrical isolation, as described, also comply with the requirements for higher isolation and the relevant test as described in EN 61800-5-1.

The PELV galvanic isolation can be shown in *Illustration 2.26*.

To maintain PELV all connections made to the control terminals must be PELV, e.g. thermistor must be reinforced/double insulated.

#### 0.25-22 kW

1. Power supply (SMPS)
2. Optocouplers, communication between AOC and BOC
3. Custom relays

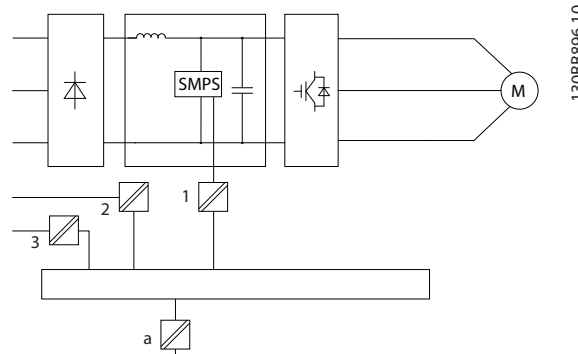

Illustration 2.25 Galvanic Isolation

#### 30-90 kW

1. Power supply (SMPS) incl. signal isolation of UDC, indicating the intermediate current voltage.
2. Gate drive that runs the IGBTs (trigger transformers/opto-couplers).
3. Current transducers.
4. Internal soft-charge, RFI and temperature measurement circuits.
5. Custom relays.

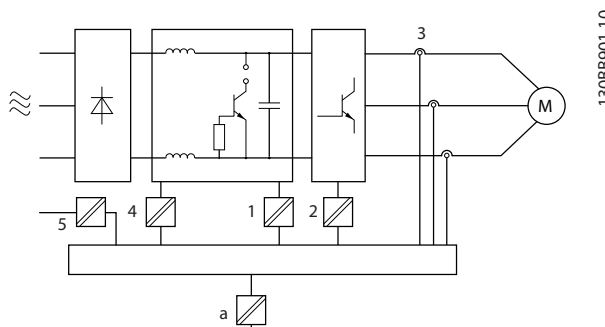

Illustration 2.26 Galvanic Isolation

The functional galvanic isolation (see *Illustration 2.25*) is for the RS-485 standard bus interface.



**Installation at high altitude:  
At altitudes above 2 km, contact Danfoss regarding PELV.**

## 2.10 Earth Leakage Current

### **⚠ WARNING**

#### DISCHARGE TIME

Touching the electrical parts could be fatal - even after the equipment has been disconnected from mains.

Also make sure that other voltage inputs have been disconnected, such as load sharing (linkage of DC intermediate circuit), as well as the motor connection for kinetic back-up.

Before touching any electrical parts, wait at least the amount of time indicated in the *Table 2.1*.

Shorter time is allowed only if indicated on the nameplate for the specific unit.

### NOTE

#### Leakage Current

The earth leakage current from the frequency converter exceeds 3.5 mA. To ensure that the earth cable has a good mechanical connection to the earth connection, the cable cross section must be at least 10 mm<sup>2</sup> or 2 rated earth wires terminated separately.

#### Residual Current Device protection RCD

This product can cause a DC current in the protective conductor. Where a residual current device (RCD) is used for protection in case of direct or indirect contact, only an RCD of Type B is allowed on the supply side of this product. Otherwise, another protective measure shall be applied, such as separation from the environment by double or reinforced insulation, or isolation from the supply system by a transformer. See also Application Note *Protection against Electrical Hazards, MN90G*.

Protective earthing of the frequency converter and the use of RCDs must always follow national and local regulations.

## 2.11 Extreme Running Conditions

### Short Circuit (Motor Phase – Phase)

The frequency converter is protected against short circuits by means of current measurement in each of the three motor phases or in the DC link. A short circuit between two output phases causes an overcurrent in the inverter. The inverter is turned off individually when the short circuit current exceeds the permitted value (Alarm 16 Trip Lock).

To protect the frequency converter against a short circuit at the load sharing and brake outputs see the design guidelines.

### Switching on the Output

Switching on the output between the motor and the frequency converter is fully permitted. The frequency converter is not damaged in any way by switching on the output. However, fault messages may appear.

### Motor-generated Over-voltage

The voltage in the intermediate circuit is increased when the motor acts as a generator. This occurs in following cases:

1. The load drives the motor (at constant output frequency from the frequency converter), that is the load generates energy.
2. During deceleration ("ramp-down") if the moment of inertia is high, the friction is low and the ramp-down time is too short for the energy to be dissipated as a loss in the frequency converter, the motor and the installation.
3. Incorrect slip compensation setting (*1-62 Slip Compensation*) may cause higher DC link voltage.

The control unit may attempt to correct the ramp if possible (*2-17 Over-voltage Control*).

The inverter turns off to protect the transistors and the intermediate circuit capacitors when a certain voltage level is reached.

### Mains Drop-out

During a mains drop-out, the frequency converter keeps running until the intermediate circuit voltage drops below the minimum stop level, which is typically 15% below the frequency converter's lowest rated supply voltage. The mains voltage before the drop-out and the motor load determines how long it takes for the inverter to coast.

## 2.11.1 Motor Thermal Protection

This is the way Danfoss protects the motor from being overheated. It is an electronic feature that simulates a bimetal relay based on internal measurements. The characteristic is shown in *Illustration 2.27*.

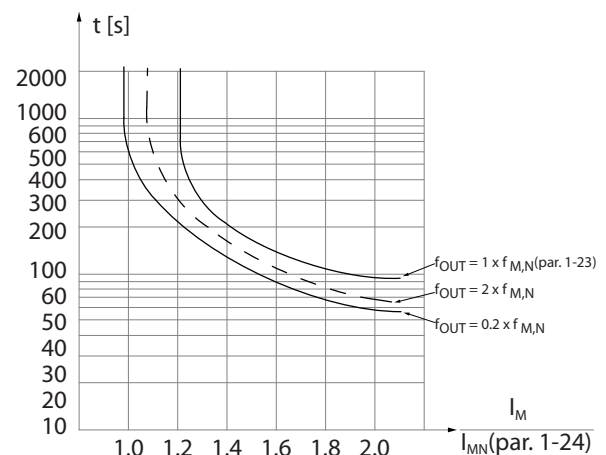

Illustration 2.27

The X-axis is showing the ratio between  $I_{motor}$  and  $I_{motor}$  nominal. The Y-axis is showing the time in seconds before

2

the ETR cuts off and trips the frequency converter. The curves are showing the characteristic nominal speed at twice the nominal speed and at 0.2x the nominal speed.

It is clear that at lower speed the ETR cuts off at lower heat due to less cooling of the motor. In that way the motor are protected from being over heated even at low speed. The ETR feature is calculating the motor temperature based on actual current and speed.

The thermistor cut-out value is  $>3\text{ k}\Omega$ .

Integrate a thermistor (PTC sensor) in the motor for winding protection.

Motor protection can be implemented using a range of techniques: PTC sensor in motor windings; mechanical thermal switch (Klixon type); or Electronic Thermal Relay (ETR).

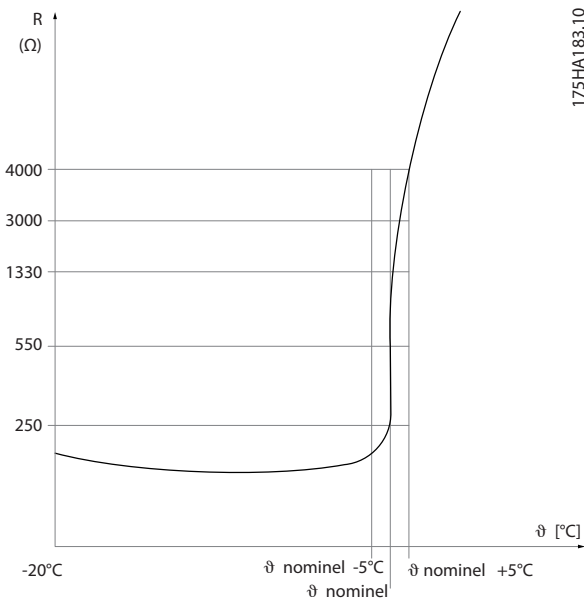

175HA183.10

Illustration 2.28

Using a digital input and 10 V as power supply:  
 Example: The frequency converter trips when the motor temperature is too high.  
 Parameter set-up:  
 Set 1-90 Motor Thermal Protection to [2] Thermistor Trip  
 Set 1-93 Thermistor Source to [6] Digital Input 29

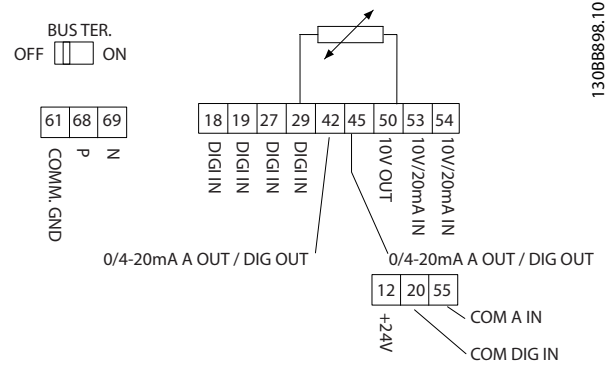

130BB898.10

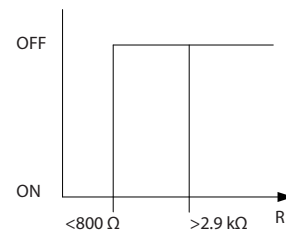
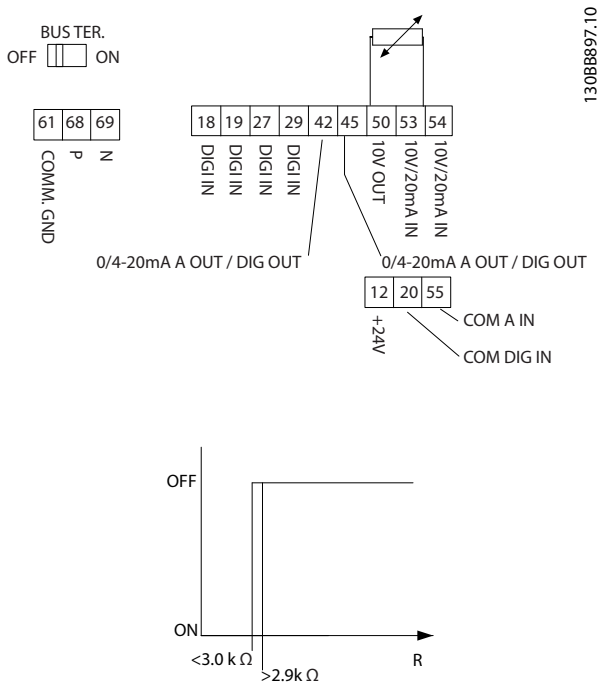

Illustration 2.29

Using an analog input and 10 V as power supply:  
 Example: The frequency converter trips when the motor temperature is too high.  
 Parameter set-up:  
 Set 1-90 Motor Thermal Protection to [2] Thermistor Trip  
 Set 1-93 Thermistor Source to [2] Analog Input 54

**NOTE**

Do not set *Analog Input 54* as reference source.



13088897.10

Illustration 2.30

Input	Supply Voltage [V]	Threshold Cut-out Values [ $\Omega$ ]
Digital	10	<math>< 800 \Rightarrow 2.9 k</math>
Analog	10	<math>< 800 \Rightarrow 2.9 k</math>

Table 2.22

**NOTE**

Check that the chosen supply voltage follows the specification of the used thermistor element.

**Summary**

With the ETR the motor is protected for being over heated and there is no need for any further motor protection. That means when the motor is heated up the ETR timer controls for how long time the motor can be running at the high temperature before it is stopped in order to prevent over heating. If the motor is overloaded without reaching the temperature where the ETR shuts of the motor.

ETR is activated in *1-90 Motor Thermal Protection*.



### 3 VLT® HVAC Basic Drive Selection

3

#### 3.1 Options and Accessories

##### 3.1.1 Local Control Panel (LCP)

Ordering no.	Description
132B0200	LCP for all IP20 units

Table 3.1

Technical data	
Enclosure	IP55 front
Max. cable length to unit	10 ft (3 m)
Communication std.	RS-485

Table 3.2

##### 3.1.2 Mounting of LCP in Panel Front

###### Step 1

Fit gasket on LCP.

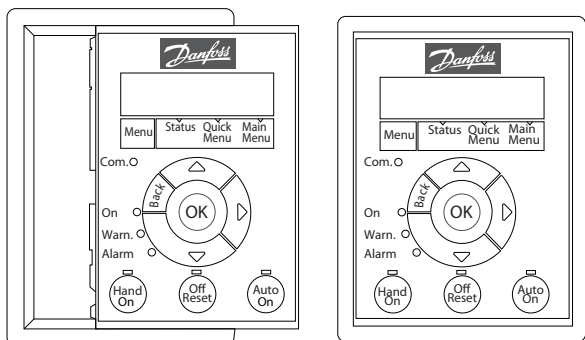
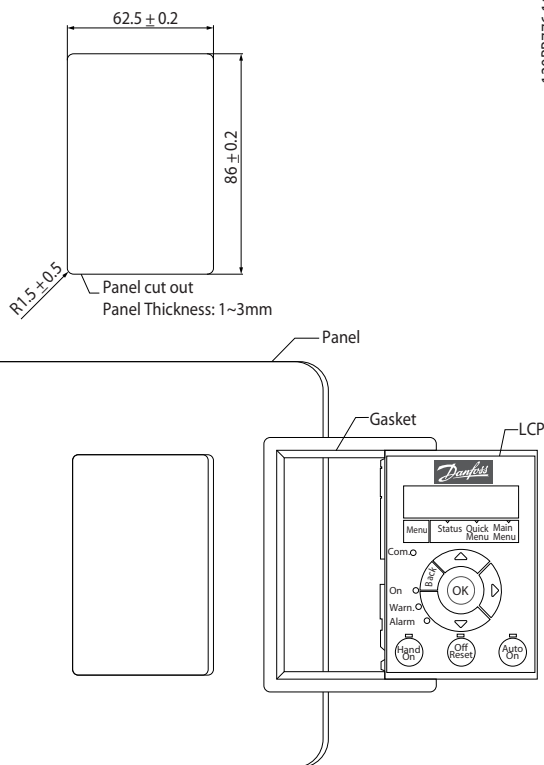

Illustration 3.1

130BB775.11

###### Step 2

Place LCP on panel, see dimensions of hole on illustration.



130BB776.11

Illustration 3.2

###### Step 3

Place bracket on back of the LCP, then slide down. Tighten screws and connect cable female side to LCP.

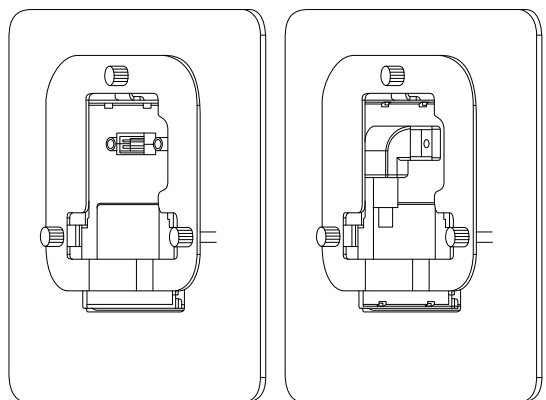

Illustration 3.3

130BB777.10

**Step 4**

Connect cable to frequency converter.

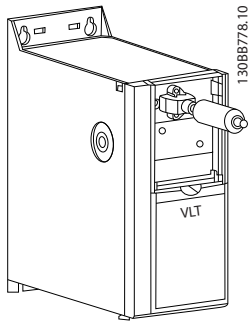

Illustration 3.4

**NOTE**

Use the provided thread cutting screws to fasten connector to the frequency converter, Tightening torque 1.3 Nm.

**H6-H8**

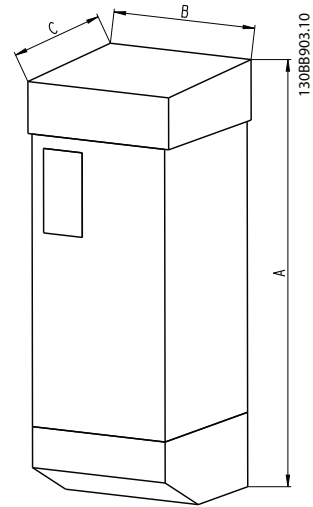

Illustration 3.6

3

**3.1.3 IP21/TYPE 1 Enclosure Kit**

IP21/TYPE 1 is an optional enclosure element available for IP20 units.

If the enclosure kit is used, an IP20 unit is upgraded to comply with enclosure IP21/TYPE 1.

**H1-H5**

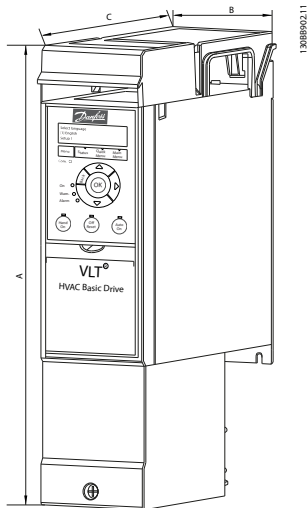

Illustration 3.5

Frame	IP class	Power			Height (mm)	Width [mm]	Depth [mm]	IP21 kit ordering no.	Type 1 kit ordering no.
		3 x 200-240 V	3 x 380-480 V	3 x 525-600 V	A	B	C		
H1	IP20	0.25-1.5 kW	0.37-1.5 kW		293	81	173	132B0212	132B0222
H2	IP20	2.2 kW	2.2-4 kW		322	96	195	132B0213	132B0223
H3	IP20	3.7 kW	5.5-7.5 kW		346	106	210	132B0214	132B0224
H4	IP20	5.5-7,5 kW	11-15 kW		374	141	245	132B0215	132B0225
H5	IP20	11 kW	18.5-22 kW		418	161	260	132B0216	132B0226
H6	IP20	15-18.5 kW	30-45 kW	18.5-30 kW	663	260	242	132B0217	132B0217
H7	IP20	22-30 kW	55-75 kW	37-55 kW	807	329	335	132B0218	132B0218
H8	IP20	37-45 kW	90 kW	75-90 kW	943	390	335	132B0219	132B0219
H9	IP20			2.2-7.5 kW	372	130	205	132B0220	132B0220
H10	IP20			11-15 kW	475	165	249	132B0221	132B0221

Table 3.3

### 3.1.4 Decoupling Plate

Use the decoupling plate for EMC correct installation.

Shown here on a H3 enclosure.

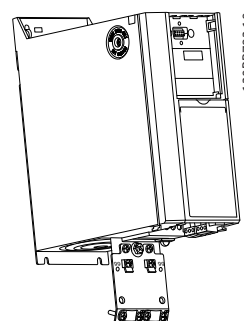

Illustration 3.7

Frame	IP class	Power [kW]			Decoupling plate
		3 x 200-240 V	3 x 380-480 V	3 x 525-600 V	
H1	IP20	0.25-1.5	0.37-1.5		132B0202
H2	IP20	2.2	2.2-4		132B0202
H3	IP20	3.7	5.5-7.5		132B0204
H4	IP20	5.5-7.5	11-15		132B0205
H5	IP20	11	18.5-22		130B0205
H6	IP20	15-18.5	30	18.5-30	132B0207
H6	IP20		37-45		132B0242
H7	IP20	22-30	55	37-55	132B0208
H7	IP20		75		132B0243
H8	IP20	37-45	90	75-90	132B0209

Table 3.4

## NOTE

For H9, H10 Drive, the decoupling plates are included in the accessory bag.

## 4 How to Order

### 4.1.1 Drive Configurator

It is possible to design a frequency converter according to the application requirements by using the ordering number system.

Frequency converters can be ordered as standard or with internal options by using a type code string, i.e.

FC-101PK25T2E20H4XXCXXSXXXXXAXBXXXXDX

Use the Internet based Drive Configurator to configure the right frequency converter for the right application and generate the type code string. The Drive Configurator will automatically generate an eight-digit sales number to be delivered to your local sales office.

Furthermore, a project list with several products can be established and sent it Danfoss sales representative.

The frequency converter configurator can be found on:  
[www.danfoss.com/drives](http://www.danfoss.com/drives).

### 4.1.2 Type Code String

1 2 3 4 5 6 7 8 9 10 11 12 13 14 15 16 17 18 19 20 21 22 23 24 25 26 27 28 29 30 31 32 33 34 35 36 37 38 39  
 F C - 1 0 1 P T H X X X S X X X A X B X C X X X X D X

13038899.10

Illustration 4.1

4

Description	Pos.	Possible choice
Product group & FC series	1-6	FC 101
Power rating	7-10	0.25-90 kW (PK25-P90K)
Number of phases	11	Three phases (T)
Mains voltage	11-12	T2: 200-240 V AC T4: 380-480 V AC T6: 525-600 V AC
Enclosure	13-15	E20: IP20/Chassis P20: IP20/Chassis with back plate E5A: IP54 P5A: IP54 with back plate
RFI filter	16-17	H1: RFI filter class A1/B H2: RFI filter class A2 H3: RFI filter class A1/B (reduced cable length) H4: RFI filter class A1
Brake	18	X: No brake chopper included
Display	19	A: Alpha Numeric Local Control Panel X: No Local Control Panel
Coating PCB	20	X: No coated PCB C: Coated PCB
Mains option	21	X: No mains option
Adaption	22	X: No adaption
Adaption	23	X: No adaption
Software release	24-27	SXXXX: Latest release - std. software
Software language	28	X: Standard
A options	29-30	AX: No A options
B options	31-32	BX: No B options
C0 options MCO	33-34	CX: No C options
C1 options	35	X: No C1 options
C option software	36-37	XX: No options
D options	38-39	DX: No D0 options

Table 4.1 Type Code Descriptions

4.2.1 Ordering Numbers: Options and Accessories

	Enclosure frame size Mains voltage	H1 [kW/HP]	H2 [kW/HP]	H3 [kW/HP]	H4 [kW/HP]	H5 [kW/HP]	H6 [kW/HP]	H7 [kW/HP]	H8 [kW/HP]
	T2 (200-240 V AC)	0.25-1.5/0.33-2	2.2/3	3.7/5	5.5-7.5/7.5-10	11/15	15-18.5/20	22-30/30	37-45/50-60
	T4 (380-480 V AC)	0.37-1.5/0.5-2	2.2-4/3-5.4	5.5-7.5/7.5-10	11-15/15-20	18.5-22/25-30	30/40	55/75	90/125
	T6 (525-600 V AC)						18.5-30/30	37-55/60	75-90/120-125
<b>Description</b>									
LCP							132B0200		
LCP panel mounting kit IP55 incl. 3 m cable							132B0201		
Decoupling plate		132B0202	132B0202	132B0204	132B0205	132B0205	132B0207	132B0208	132B0209
IP21 option		132B0212	132B0213	132B0214	132B0215	132B0216	132B0217	132B0218	132B0219
Nema Type 1 Kit		132B0222	132B0223	132B0224	132B0225	132B0226	132B0217	132B0218	132B0219

Table 4.2 Options and Accessories

## 4.2.2 Harmonic Filters

4

3x380-480 V 50 Hz					
Power [kW]	Drive input current Continuous [A]	Default switching frequency [kHz]	THID level [%]	Order number filter IP00	Code number filter IP20
22	41.5	4	4	130B1397	130B1239
30	57	4	3	130B1398	130B1240
37	70	4	3	130B1442	130B1247
45	84	3	3	130B1442	130B1247
55	103	3	5	130B1444	130B1249
75	140	3	4	130B1445	130B1250
90	176	3	4	130B1445	130B1250

Table 4.3 AHF Filters (5% current distortion)

3x440-480 V 60 Hz					
Power [kW]	Drive input current Continuous [A]	Default switching frequency [kHz]	THID level [%]	Order number filter IP00	Code number filter IP20
22	34.6	4	3	130B1792	130B1757
30	49	4	3	130B1793	130B1758
37	61	4	3	130B1794	130B1759
45	73	3	4	130B1795	130B1760
55	89	3	4	130B1796	130B1761
75	121	3	5	130B1797	130B1762
90	143	3	5	130B1798	130B1763

Table 4.5 AHF Filters (5% current distortion)

3x380-480 V 50 Hz					
Power [kW]	Drive input current Continuous [A]	Default switching frequency [kHz]	THID level [%]	Order number filter IP00	Code number filter IP20
22	41.5	4	6	130B1274	130B1111
30	57	4	6	130B1275	130B1176
37	70	4	9	130B1291	130B1201
45	84	3	9	130B1291	130B1201
55	103	3	9	130B1292	130B1204
75	140	3	8	130B1294	130B1213
90	176	3	8	130B1294	130B1213

Table 4.4 AHF Filters (10% current distortion)

3x440-480 V 60 Hz					
Power [kW]	Drive input current Continuous [A]	Default switching frequency [kHz]	THID level [%]	Order number filter IP00	Code number filter IP20
22	34.6	4	6	130B1775	130B1487
30	49	4	8	130B1776	130B1488
37	61	4	7	130B1777	130B1491
45	73	3	9	130B1778	130B1492
55	89	3	8	130B1779	130B1493
75	121	3	9	130B1780	130B1494
90	143	3	10	130B1781	130B1495

Table 4.6 AHF Filters (10% current distortion)

### 4.2.3 External RFI Filter

External filters to fulfil A1 50 meters/B1 20 meters

Power [kW] Size 380-480 V	Type	A	B	C	D	E	F	G	H	I	J	K	L1	Torque [Nm]	Weight [kg]	Ordering Number
0.37-2.2	FN3258-7-45	190	40	70	160	180	20	4.5	1	10.6	M5	20	31	0.7-0.8	0.5	132B0244
3-7.5	FN3258-16-45	250	45	70	220	235	25	4.5	1	10.6	M5	22.5	31	0.7-0.8	0.8	132B0245
11-15	FN3258-30-47	270	50	85	240	255	30	5.4	1	10.6	M5	25	40	1.9-2.2	1.2	132B0246
18.5-22	FN3258-42-47	310	50	85	280	295	30	5.4	1	10.6	M5	25	40	1.9-2.2	1.4	132B0247

Table 4.7

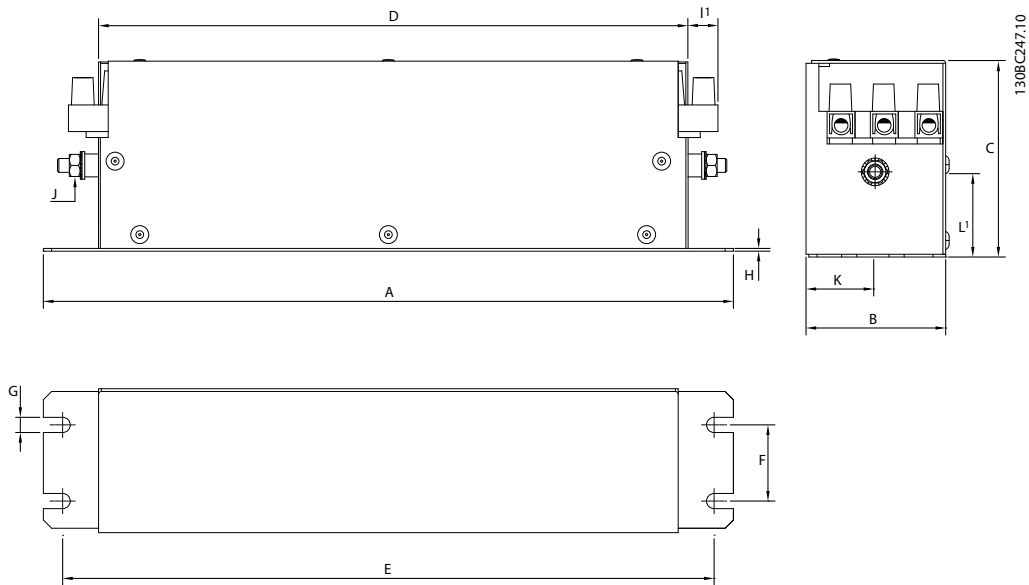

Illustration 4.2



## 5 How to Install

### 5.1.1 Dimensions

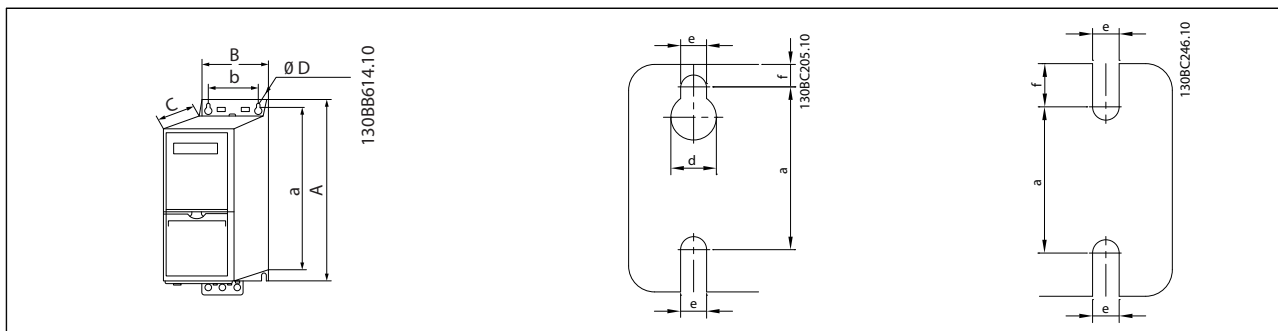

Table 5.1

Enclosure		Power [kW]			Height [mm]			Width [mm]		Depth [mm]	Mounting hole [mm]			Max. Weight [kg]
Frame	IP Class	3x200-240 V	3x380-480 V	3x525-600 V	A	"A incl Decoupling Plate"	a	B	b	C	d	e	f	kg
H1	IP20	0.25-1.5	0.37-1.5		195	273	183	75	56	168	9	4.5	5.3	2.1
H2	IP20	2.2	2.2-4.0		227	303	212	90	65	190	11	5.5	7.4	3.4
H3	IP20	3.7	5.5-7.5		255	329	240	100	74	206	11	5.5	8.1	4.5
H4	IP20	5.5-7.5	11-15		296	359	275	135	105	241	12.6	7	8.4	7.9
H5	IP20	11	18.5-22		334	402	314	150	120	255	12.6	7	8.5	9.5
H6	IP20	15-18.5	30-45	18.5-30	518	595/635 (45 kW)	495	239	200	242	-	8.5	15	24.5
H7	IP20	22-30	55-75	37-55	550	630/690 (75 kW)	521	313	270	335	-	8.5	17	36
H8	IP20	37-45	90	75-90	660	800	631	375	330	335	-	8.5	17	51
H9	IP20			2.2-7.5	269	374	257	130	110	205	11	5.5	9	6.6
H10	IP20			11-15	399	419	380	165	140	248	12	6.8	7.5	12
I2	IP54		0.75-4.0		332	-	318.5	115	74	225	11	5.5	9	5.3
I3	IP54		5.5-7.5		368	-	354	135	89	237	12	6.5	9.5	7.2
I4	IP54		11-18.5		476	-	460	180	133	290	12	6.5	9.5	13.8
I5	IP54		11-18.5		480	-	454	242	210	260	19	9	9	23
I6	IP54		22-37		650	-	624	242	210	260	19	9	9	27
I7	IP54		45-55		680	-	648	308	272	310	19	9	9.8	45
I8	IP54		75-90		770	-	739	370	334	335	19	9	9.8	65

Table 5.2

The dimensions are only for the physical units, but when installing in an application it is necessary to add space for free air passage both above and below the units. The amount of space for free air passage is listed in *Table 5.3*:

Enclosure		Clearance needed for free air passage [mm]	
Frame	IP class	Above unit	Below unit
H1	20	100	100
H2	20	100	100
H3	20	100	100
H4	20	100	100
H5	20	100	100
H6	20	200	200
H7	20	200	200
H8	20	225	225
H9	20	100	100
H10	20	200	200
I2	54	100	100
I3	54	100	100
I4	54	100	100
I5	54	200	200
I6	54	200	200
I7	54	200	200
I8	54	225	225

**Table 5.3 Clearance Needed for Free Air Passage [mm]**

## 5.1.2 Shipping Dimensions

5

Enclosure frame size	H1	H2	H3	H4	H5	H6	H7	H8	H9	H10	I2	I3	I4	I5	I6	I7	I8
<b>Mains voltage</b>																	
<b>T2 (200-240 V AC) [kW/Hp]</b>	0.25-1.5/ 0.33-2	2.2/ 3	3.7/ 5	5.5-7.5/ 7.5-10	11/ 15	15-18.5/ 20	22-30/ 30-40	37-45/ 50-60									
<b>T4 (380-480 V AC) [kW/Hp]</b>	0.37-1.5/ 0.5-2	2.2-4/ 3-5.4	5.5-7.5/ 7.5-10	11-15/ 15-20	18.5-22/ 25-30	30-45/ 40-60	55-75/ 73-100	90/ 125			0.75/ 1.0-5.0	5.5-7.5/ 7.5-10	11-18.5/ 15-25	11-18.5/ 15-25	22-37/ 30-50	45-55/ 60-70	75-90/ 125
<b>T6 (525-600 V AC) [kW/Hp]</b>						18.5-30/ 30-40	37-55/ 60-70	75-90/ 100-125	2.2-7.5/ 3.0-10	11-15/ 15-20							
<b>IP frame</b>						<b>IP20</b>									<b>IP54</b>		
<b>Maximum weight [kg]</b>	2.1	3.4	4.5	7.9	9.5	24.5	36	51	6.6	11.5	6.1	7.8	13.8	23.3	28.3	41.5	60.5
<b>Shipping dimensions</b>																	
<b>Height [mm/inch]</b>	255/ 10.0	300/ 11.8	330/ 13.0	380/ 15.0	420 / 16.5	850	850	850	380	500	440	470	588	850	850	850	950
<b>Width [mm/inch]</b>	154/ 6.1	170/ 6.7	188/ 7.4	250/ 9.8	290/ 11.4	370	410	490	290	330	200	240	285	370	370	410	490
<b>Depth [mm/inch]</b>	235/ 9.3	260/ 10.2	282/ 11.1	375/ 14.8	375/ 14.8	460	540	490	200	350	300	330	385	460	460	540	490

Table 5.4

### 5.1.3 Side-by-Side Installation

The frequency converter can be mounted side-by-side and requires the clearance above and below for cooling.

Frame	IP class	Power [kW]			Clearance above/below [mm/inch]
		3x200-240 V	3x380-480 V	3x525-600 V	
H1	IP20	0.25-1.5	0.37-1.5		100/4
H2	IP20	2.2	2.2-4		100/4
H3	IP20	3.7	5.5-7.5		100/4
H4	IP20	5.5-7.5	11-15		100/4
H5	IP20	11	18.5-22		100/4
H6	IP20	15-18.5	30-45	18.5-30	200/7.9
H7	IP20	22-30	55-75	37-55	200/7.9
H8	IP20	37-45	90	75-90	225/8.9
H9	IP20			2.2-7.5	100/4
H10	IP20			11-15	200/7.9

Table 5.5

#### NOTE

With IP21/Nema Type1 option kit mounted, a distance of 50 mm between the units is required.

### 5.1.4 Field Mounting

IP21/TYPE 1 kits are recommended.

## 5.2 Electrical Data

### 5.2.1 Electrical Overview

5

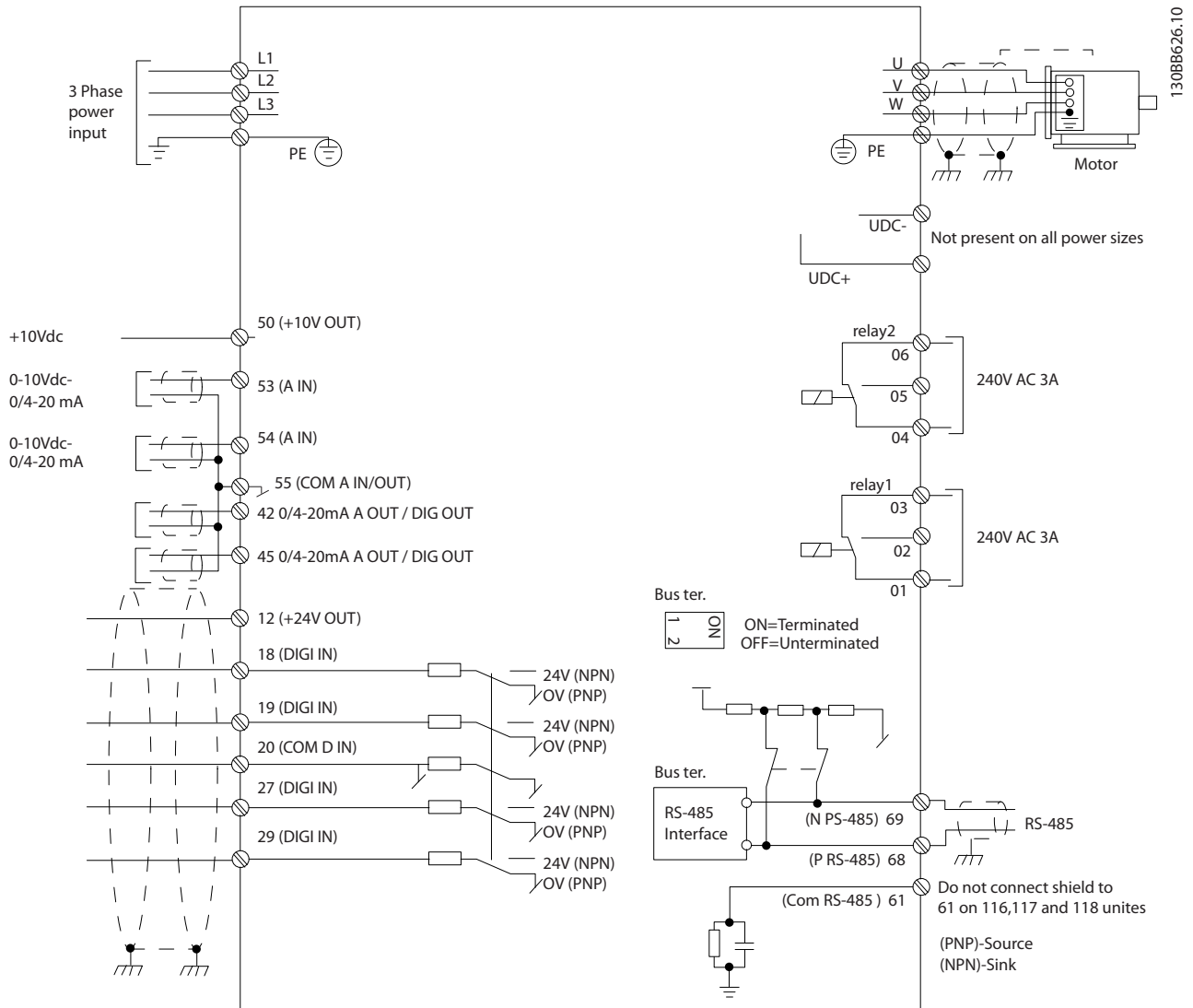

Illustration 5.1

## NOTE

There is no access to UDC- and UDC+ on the following units:

- IP20 380-480 V 30-90 kW
- IP20 200-240 V 15-45 kW
- IP20 525-600 V 2.2-90 kW
- IP54 380-480 V 22-90 kW

## 5.2.2 Electrical Installation in General

All cabling must comply with national and local regulations on cable cross-sections and ambient temperature. Copper conductors required, (75 °C) recommended.

Frame	IP class	Power [kW]		Torque [Nm]					
		3x200-240 V	3x380-480 V	Line	Motor	DC connection	Control terminals	Earth	Relay
H1	IP20	0.25-1.5	0.37-1.5	1.4	0.8	0.8	0.5	0.8	0.5
H2	IP20	2.2	2.2-4	1.4	0.8	0.8	0.5	0.8	0.5
H3	IP20	3.7	5.5-7.5	1.4	0.8	0.8	0.5	0.8	0.5
H4	IP20	5.5-7.5	11-15	1.2	1.2	1.2	0.5	0.8	0.5
H5	IP20	11	18.5-22	1.2	1.2	1.2	0.5	0.8	0.5
H6	IP20	15-18	30-45	4.5	4.5	-	0.5	3	0.5
H7	IP20	22-30	55	10	10	-	0.5	3	0.5
H7	IP20	-	75	14	14	-	0.5	3	0.5
H8	IP20	37-45	90	24 <sup>2</sup>	24 <sup>2</sup>	-	0.5	3	0.5

Table 5.6

Frame	IP class	Power [kW]		Torque [Nm]					
		3x380-480 V	Line	Motor	DC connection	Control terminals	Earth	Relay	
I2	IP54	0.75-4.0	1.4	0.8	0.8	0.5	0.8	0.5	
I3	IP54	5.5-7.5	1.4	0.8	0.8	0.5	0.8	0.5	
I4	IP54	11-18.5	1.4	0.8	0.8	0.5	0.8	0.5	
I5	IP54	11-18.5	1.8	1.8	-	0.5	3	0.6	
I6	IP54	22-37	4.5	4.5	-	0.5	3	0.6	
I7	IP54	45-55	10	10	-	0.5	3	0.6	
I8	IP54	75-90	14/24 <sup>1</sup>	14/24 <sup>1</sup>	-	0.5	3	0.6	

Table 5.7

Frame	IP class	Power [kW]		Torque [Nm]					
		3x525-600 V	Line	Motor	DC connection	Control terminals	Earth	Relay	
H9	IP20	2.2-7.5	1.8	1.8	not recommended	0.5	3	0.6	
H10	IP20	11-15	1.8	1.8	not recommended	0.5	3	0.6	
H6	IP20	18.5-30	4.5	4.5	-	0.5	3	0.5	
H7	IP20	37-55	10	10	-	0.5	3	0.5	
H8	IP20	75-90	14/24 <sup>1</sup>	14/24 <sup>1</sup>	-	0.5	3	0.5	

Table 5.8 Details of Tightening Torques

<sup>1</sup> Cable dimensions  $\leq 95 \text{ mm}^2$ 
<sup>2</sup> Cable dimensions  $> 95 \text{ mm}^2$

### 5.2.3 Connecting to Mains and Motor

The frequency converter is designed to operate all standard three-phased asynchronous motors. For maximum cross-section on wires see 8.2 *General Specifications*.

- Use a shielded/armored motor cable to comply with EMC emission specifications, and connect this cable to both the decoupling plate and the motor metal.
- Keep motor cable as short as possible to reduce the noise level and leakage currents.
- For further details on mounting of the decoupling plate, see *FC 101 De-coupling Plate Mounting Instruction MI02Q*.
- Also see *EMC-Correct Installation in the VLT® HVAC Basic Design Guide, MG18C*.

1. Mount the earth wires to earth terminal.
2. Connect motor to terminals U, V and W.
3. Mount mains supply to terminals L1, L2 and L3 and tighten.

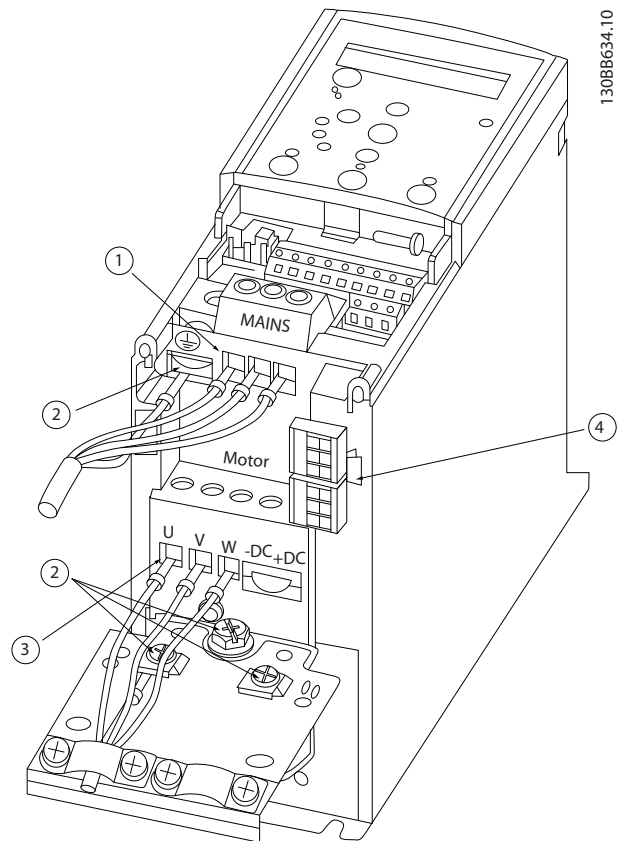

**Illustration 5.2 H1-H5 Frame**  
 IP20 200-240 V 0.25-11 kW and IP20 380-480 V 0.37-22 kW.

1	Line
2	Earth
3	Motor
4	Relays

**Table 5.9**

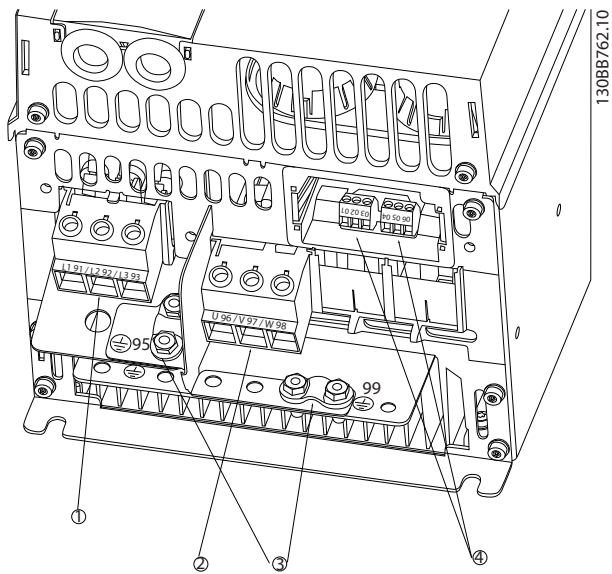

**Illustration 5.3 H6 Frame**  
 IP20 380-480 V 30-45 kW  
 IP20 200-240 V 15-18.5 kW  
 IP20 525-600 V 22-30 kW

1	Line
2	Motor
3	Earth
4	Relays

**Table 5.10**

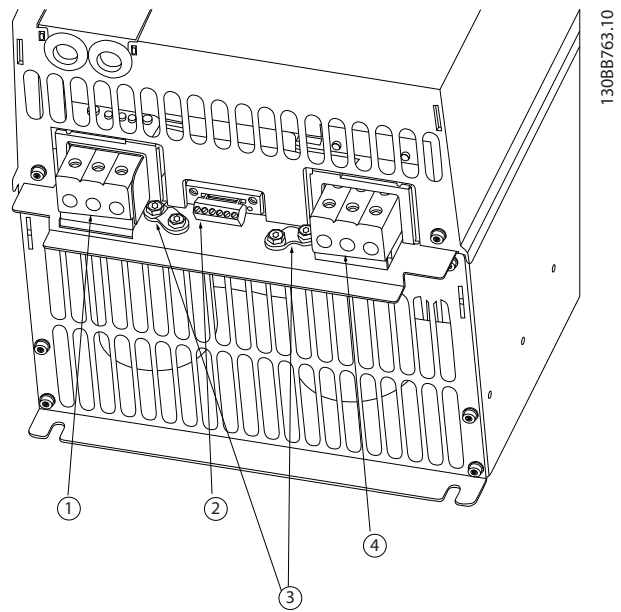

**Illustration 5.4 H7 Frame**  
 IP20 380-480 V 55-75 kW  
 IP20 200-240 V 22- 30 kW  
 IP20 525-600 V 45-55 kW

1	Line
2	Relays
3	Earth
4	Motor

**Table 5.11**



5

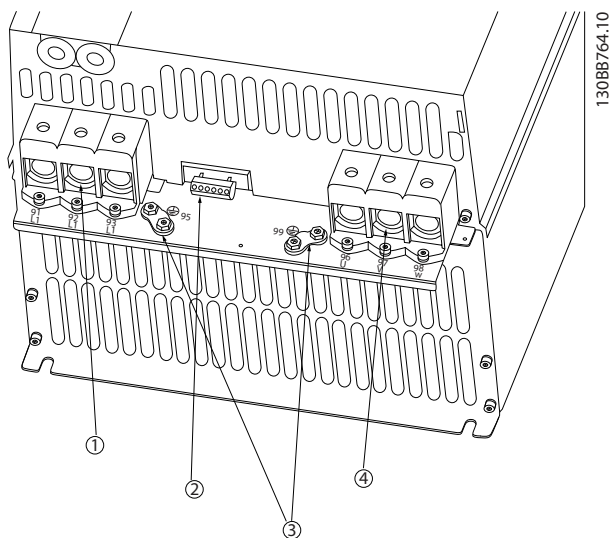

**Illustration 5.5 H8 Frame**  
 IP20 380-480 V 90 kW  
 IP20 200-240 V 37-45 kW  
 IP20 525-600 V 75-90 kW

1	Line
2	Relays
3	Earth
4	Motor

Table 5.12

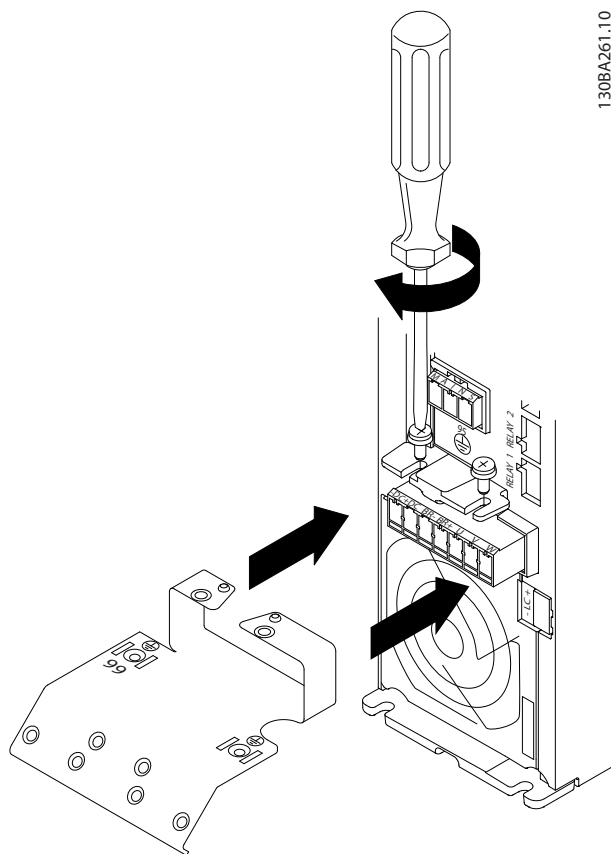
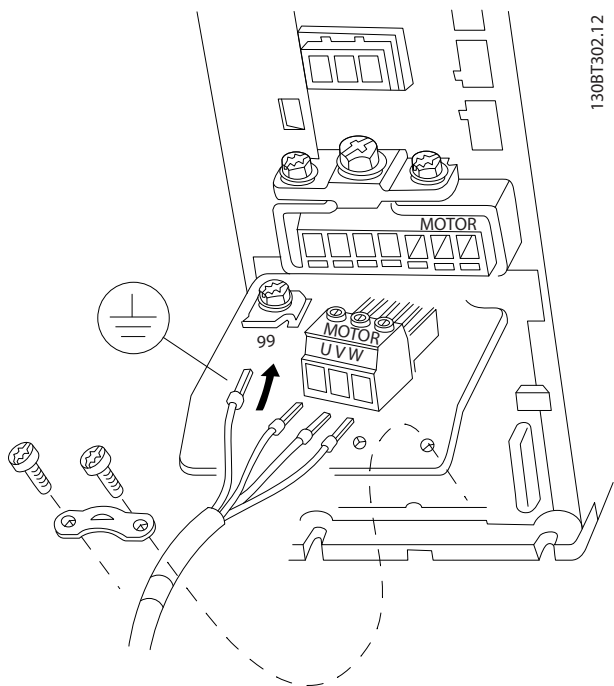

Illustration 5.7



**Illustration 5.6 H9 Frame**  
 IP20 600 V 2.2-7.5 kW

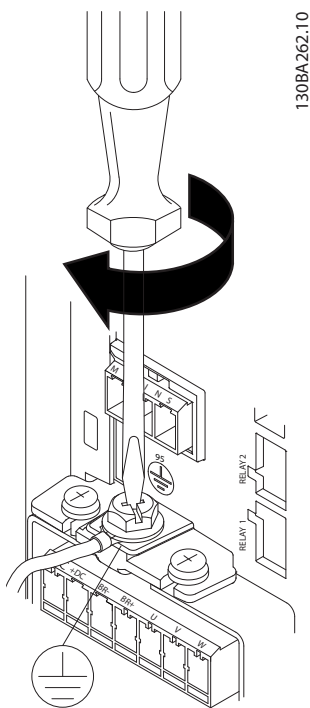

Illustration 5.8

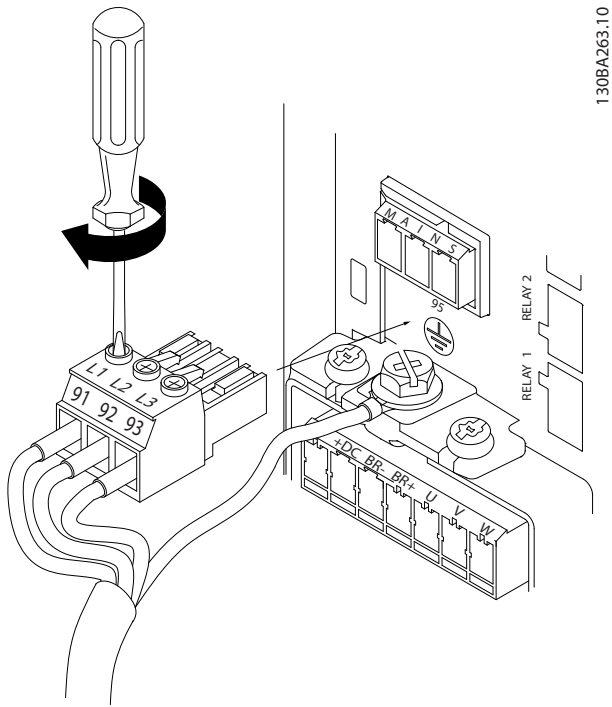

Illustration 5.9

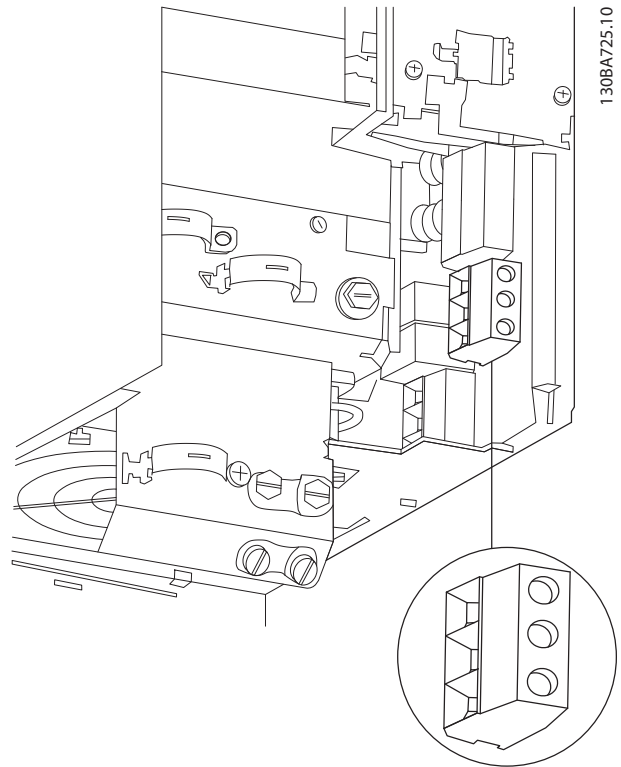

Illustration 5.11 H10 Frame  
IP20 600 V 11-15 kW

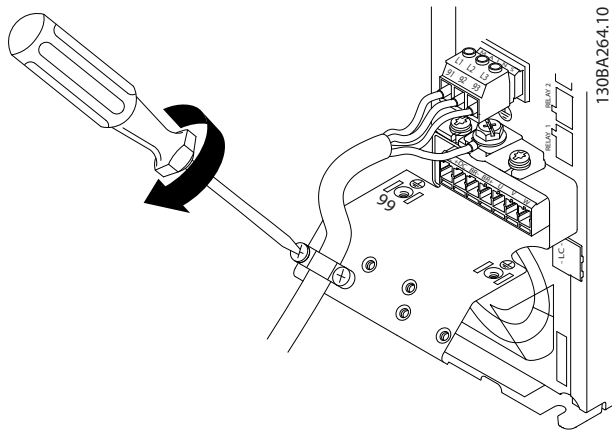
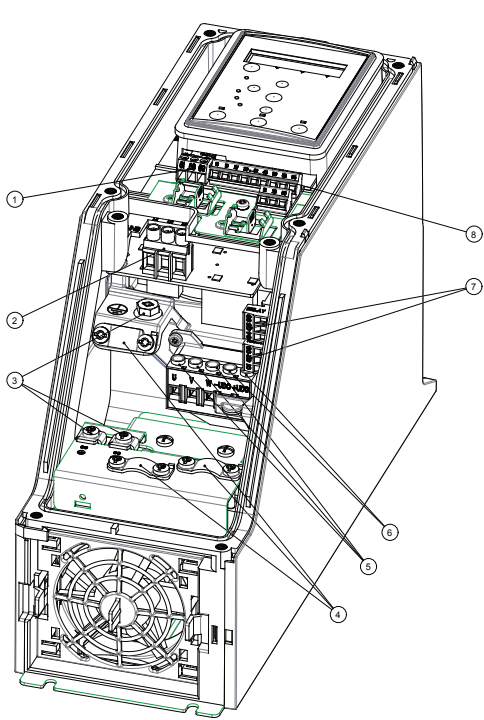

Illustration 5.10

5



**Illustration 5.12 I2 Frame**  
IP54 380-480 V 0.75-4.0 kW

1	RS-485
2	Line in
3	Earth
4	Wire clamps
5	Motor
6	UDC
7	Relays
8	I/O

**Table 5.13**

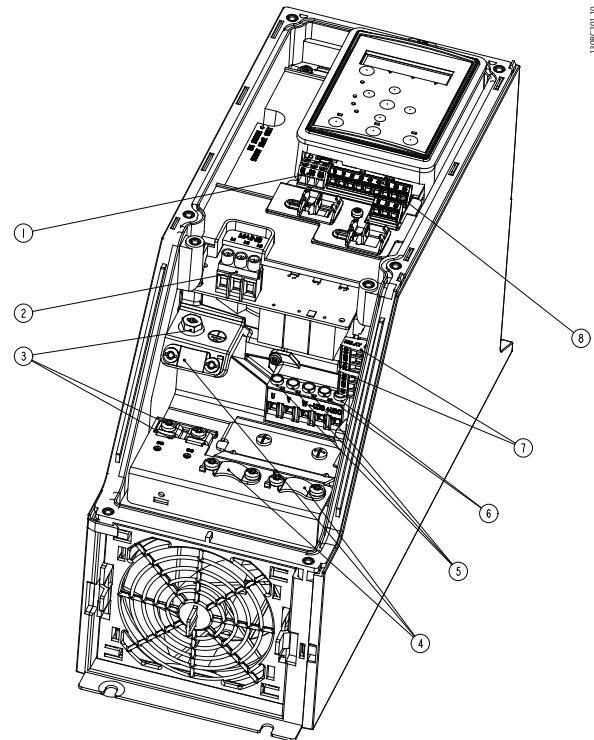

**Illustration 5.13 I3 Frame**  
IP54 380-480 V 5.5-7.5 kW

1	RS-485
2	Line in
3	Earth
4	Wire clamps
5	Motor
6	UDC
7	Relays
8	I/O

**Table 5.14**

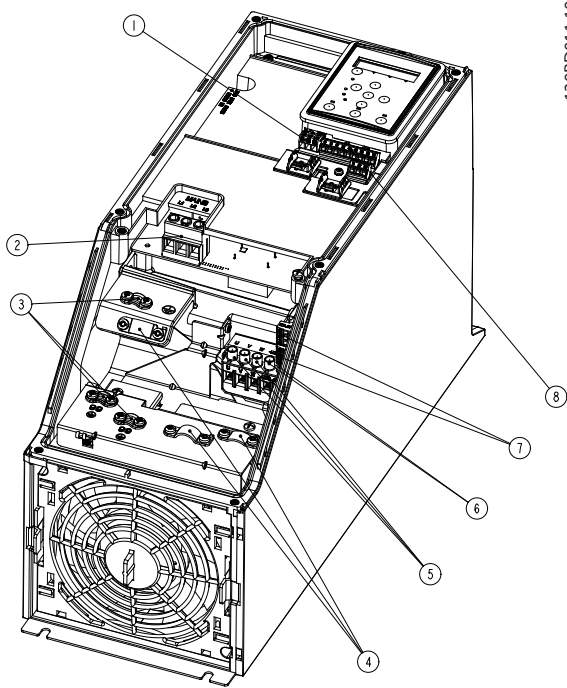

130BD011.10

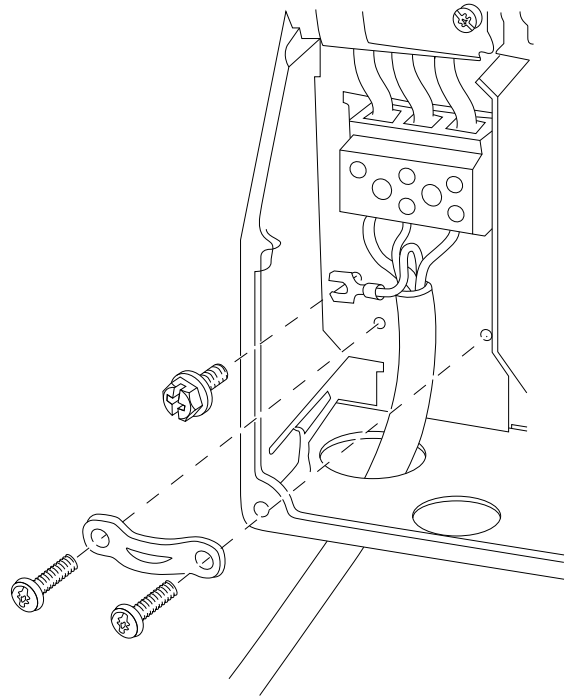

130BT326.10

Illustration 5.14 I4 Frame  
IP54 380-480 V 0.75-4.0 kW

Illustration 5.16 I6 Frame  
IP54 380-480 V 22-37 kW

1	RS-485
2	Line in
3	Earth
4	Wire clamps
5	Motor
6	UDC
7	Relays
8	I/O

Table 5.15

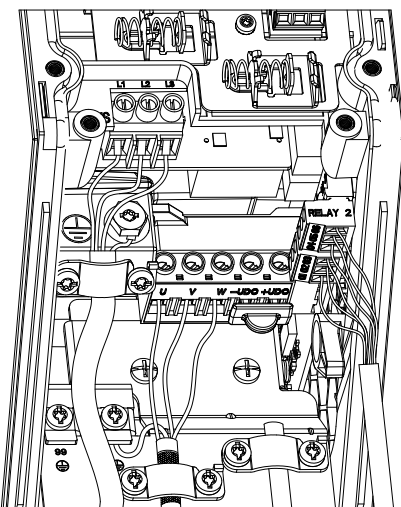

130BC203.10

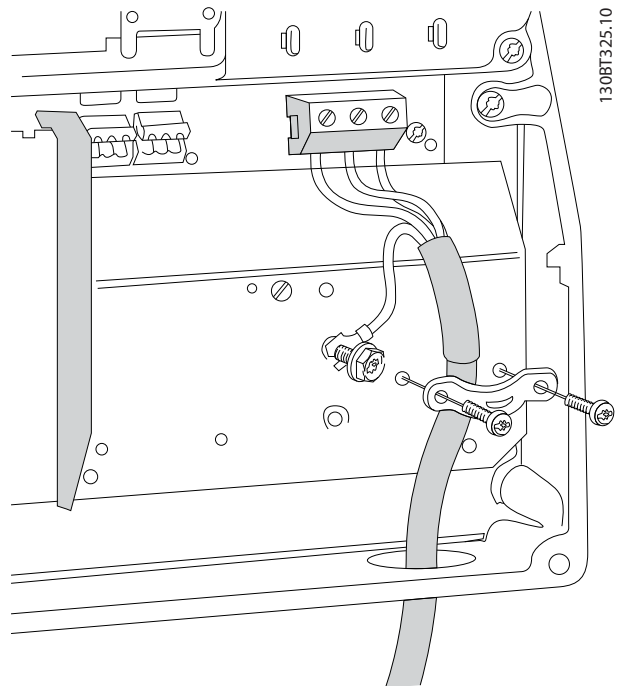

130BT325.10

Illustration 5.15 IP54 I2-I3-I4 frame

Illustration 5.17 I6 Frame  
IP54 380-480 V 22-37 kW

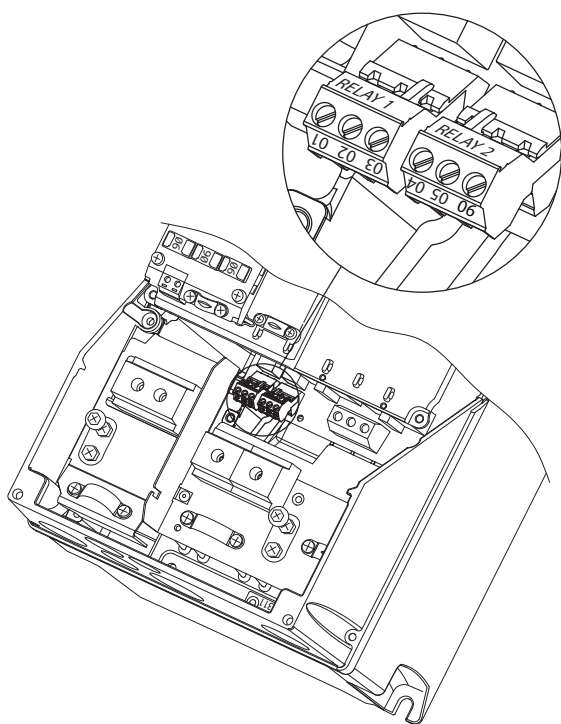

130BA215:10

Illustration 5.18 I6 Frame  
IP54 380-480 V 22-37 kW

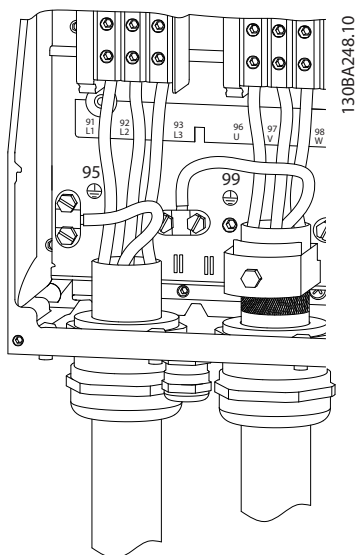

130BA248:10

Illustration 5.19 I7, I8 Frame  
IP54 380-480 V 45-55 kW  
IP54 380-480 V 75-90 kW

## 5.2.4 Fuses

### Branch circuit protection

In order to protect the installation against electrical and fire hazard, all branch circuits in an installation, switch gear, machines etc., must be short-circuit and overcurrent protected according to national/international regulations.

### Short circuit protection

Danfoss recommends using the fuses mentioned in the following tables to protect service personnel or other equipment in case of an internal failure in the unit or short-circuit on DC-link. The frequency converter provides full short circuit protection in case of a short-circuit on the motor.

### Overcurrent protection

Provide overload protection to avoid overheating of the cables in the installation. Overcurrent protection must always be carried out according to national regulations. Fuses must be designed for protection in a circuit capable of supplying a maximum of 100,000  $A_{rms}$  (symmetrical), 480 V maximum.

### Non UL compliance

If UL/cUL is not to be complied with, Danfoss recommends using the fuses mentioned in *Table 5.16*, which ensures compliance with IEC 61800-5-1.

In case of malfunction, not following the fuse recommendation may result in damage to the frequency converter.

Power [kW]	Circuit Breaker		Fuse				
	UL	Non UL	UL				Non UL
			Bussmann Type RK5	Bussmann Type RK1	Bussmann Type J	Bussmann Type T	Max fuse Type G
<b>3x200-240 V IP20</b>							
0.25			FRS-R-10	KTN-R10	JKS-10	JIN-10	10
0.37			FRS-R-10	KTN-R10	JKS-10	JIN-10	10
0.75			FRS-R-10	KTN-R10	JKS-10	JIN-10	10
1.5			FRS-R-10	KTN-R10	JKS-10	JIN-10	10
2.2			FRS-R-15	KTN-R15	JKS-15	JIN-15	16
3.7			FRS-R-25	KTN-R25	JKS-25	JIN-25	25
5.5			FRS-R-50	KTN-R50	JKS-50	JIN-50	50
7.5			FRS-R-50	KTN-R50	JKS-50	JIN-50	50
11			FRS-R-80	KTN-R80	JKS-80	JIN-80	65
15	Cutler-Hammer EGE3100FFG	Moeller NZMB1- A125	FRS-R-100	KTN-R100			125
18.5			FRS-R-100	KTN-R100			125
22	Cutler-Hammer JGE3150FFG	Moeller NZMB1- A160	FRS-R-150	KTN-R150			160
30			FRS-R-150	KTN-R150			160
37	Cutler-Hammer JGE3200FFG	Moeller NZMB1- A200	FRS-R-200	KTN-R200			200
45			FRS-R-200	KTN-R200			200
<b>3x380-480 V IP20</b>							
0.37			FRS-R-10	KTS-R10	JKS-10	JJS-10	10
0.75			FRS-R-10	KTS-R10	JKS-10	JJS-10	10
1.5			FRS-R-10	KTS-R10	JKS-10	JJS-10	10
2.2			FRS-R-15	KTS-R15	JKS-15	JJS-15	16
3			FRS-R-15	KTS-R15	JKS-15	JJS-15	16
4			FRS-R-15	KTS-R15	JKS-15	JJS-15	16
5.5			FRS-R-25	KTS-R25	JKS-25	JJS-25	25
7.5			FRS-R-25	KTS-R25	JKS-25	JJS-25	25
11			FRS-R-50	KTS-R50	JKS-50	JJS-50	50
15			FRS-R-50	KTS-R50	JKS-50	JJS-50	50
18.5			FRS-R-80	KTS-R80	JKS-80	JJS-80	65
22			FRS-R-80	KTS-R80	JKS-80	JJS-80	65
30	Cutler-Hammer EGE3125FFG	Moeller NZMB1- A125	FRS-R-80	KTS-R80	JKS-R80	JJS-R80	80
37			FRS-R-100	KTS-R100	JKS-R100	JJS-R100	100
45			FRS-R-125	KTS-R125	JKS-R125	JJS-R125	125
55	Cutler-Hammer JGE3200FFG	Moeller NZMB1- A200	FRS-R-150	KTS-R150	JKS-R150	JJS-R150	150
75			FRS-R-200	KTS-R200	JKS-R200	JJS-R200	200
90	Cutler-Hammer JGE3250FFG	Moeller NZMB2- A250	FRS-R-250	KTS-R250	JKS-R250	JJS-R250	250

5

Table 5.16

5

	Circuit Breaker		Fuse				
	UL	Non UL	UL			Non UL	
Power [kW]			Bussmann Type RK5	Bussmann Type RK1	Bussmann Type J	Bussmann Type T	Max fuse Type G
<b>3x525-600 V IP20</b>							
2.2				KTS-R20			20
3				KTS-R20			20
3.7				KTS-R20			20
5.5				KTS-R20			20
7.5				KTS-R20			30
11				KTS-R30			35
15				KTS-R30			35
18.5	Cutler-Hammer EGE3080FFG	Cutler-Hammer EGE3080FFG	FRS-R-80	KTN-R80			80
22			FRS-R-80	KTN-R80			80
30			FRS-R-80	KTN-R80			80
37	Cutler-Hammer JGE3125FFG	Cutler-Hammer JGE3125FFG	FRS-R-125	KTN-R125			125
45			FRS-R-125	KTN-R125			125
55			FRS-R-125	KTN-R125			125
75	Cutler-Hammer JGE3200FAG	Cutler-Hammer JGE3200FAG	FRS-R-200	KTN-R200			200
90			FRS-R-200	KTN-R200			200
<b>3x380-480 V IP54</b>							
0.75							
1.5							
2.2							
3							
4							
5.5							
7.5							
11							
15							
18.5							
22	Moeller NZMB1-A125						125
30							125
37							125
45	Moeller NZMB2-A160						160
55							160
75	Moeller NZMB2-A250						200
90							200

Table 5.17 Fuses

### 5.2.5 EMC-Correct Electrical Installation

General points to be observed to ensure EMC-correct electrical installation.

- Use only screened/armoured motor cables and screened/armoured control cables.
- Connect the screen to earth at both ends.
- Avoid installation with twisted screen ends (pigtailed), since this ruins the screening effect at

high frequencies. Use the cable clamps provided instead.

- It is important to ensure good electrical contact from the installation plate through the installation screws to the metal cabinet of the frequency converter.
- Use starwashers and galvanically conductive installation plates.
- Do not use unscreened/unarmoured motor cables in the installation cabinets.

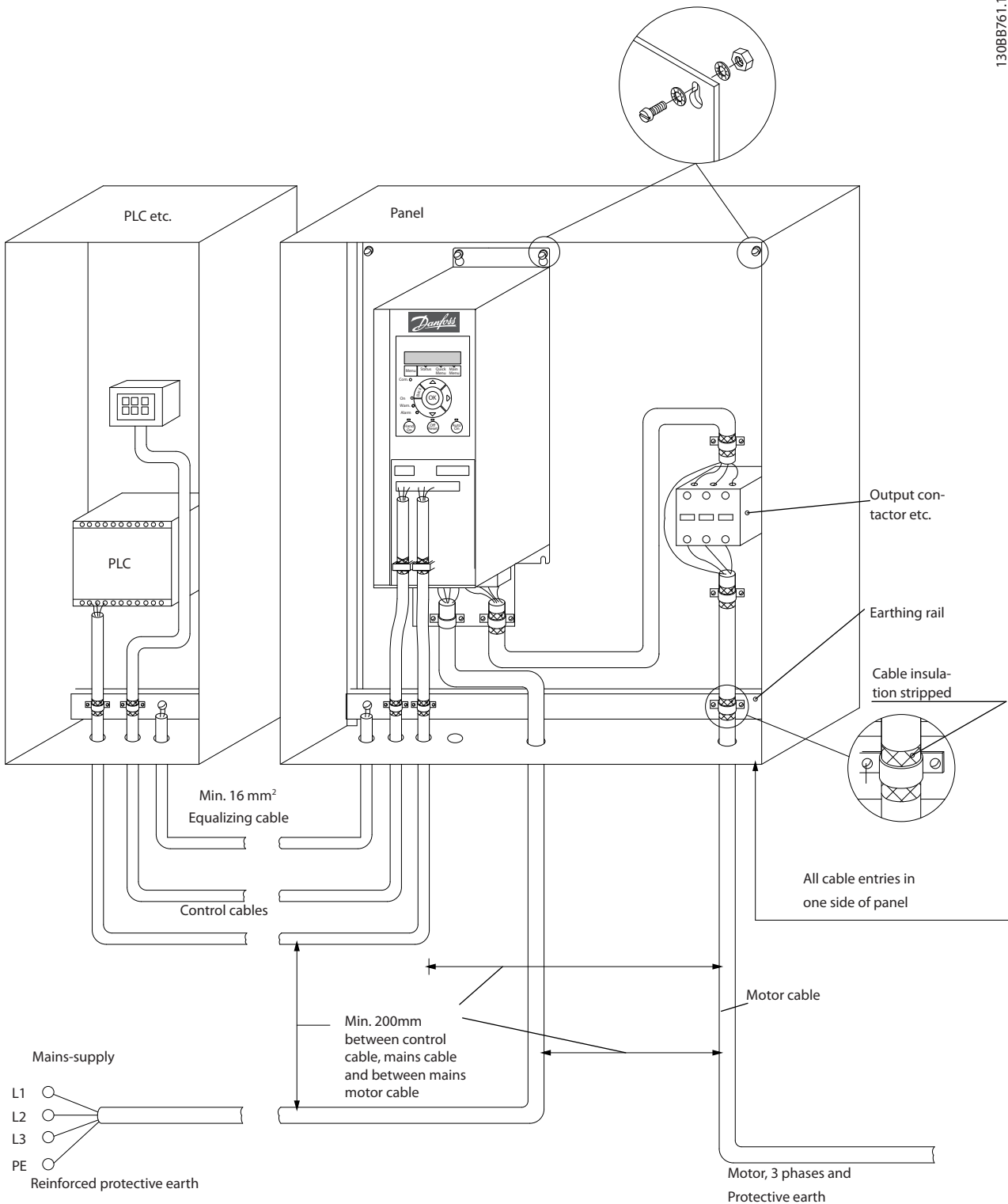

Illustration 5.20 EMC-correct Electrical Installation

**NOTE**

For North America use metal conduits instead of shielded cables.



### 5.2.6 Control Terminals

IP20 200-240 V 0.25-11 kW and IP20 380-480 V 0.37-22 kW:

5

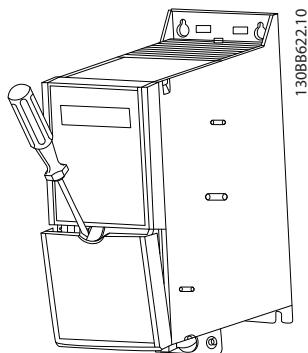

Illustration 5.21 Location of Control Terminals

1. Place a screwdriver behind the terminal cover to activate snap.
2. Tilt the screwdriver outwards to open the cover.

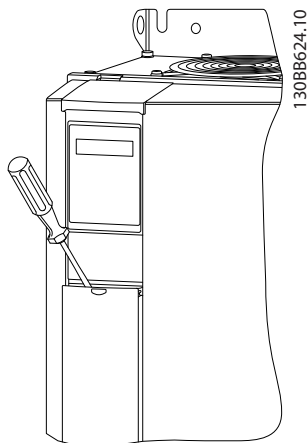

Illustration 5.22 IP20 380-480 V 30-90 kW

1. Place a screwdriver behind the terminal cover to activate snap.
2. Tilt the screwdriver outwards to open the cover.

Digital input 18, 19 and 27 mode is set in 5-00 Digital Input Mode (PNP is default value) and digital input 29 mode is set in 5-03 Digital Input 29 Mode (PNP is default value).

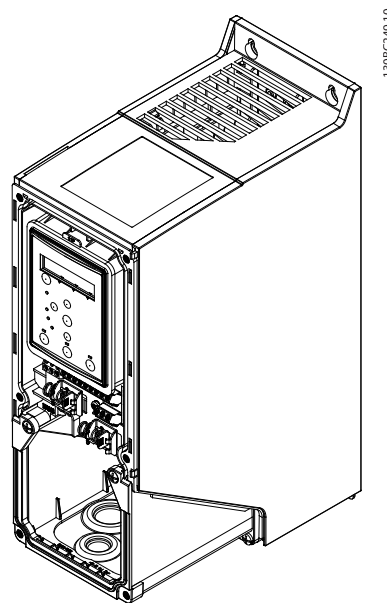

Illustration 5.23 IP54 400 V 0.75-7.5 kW

1. Remove the front cover.

#### Control terminals

Illustration 5.24 shows all control terminals of the frequency converter. Applying Start (term. 18), connection between terminal 12-27 and an analog reference (term. 53 or 54 and 55) make the frequency converter run.

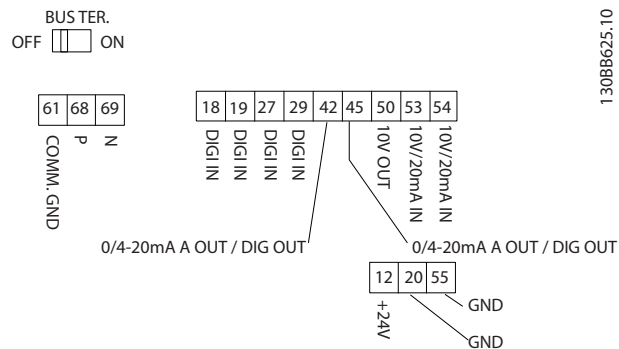

Illustration 5.24 Control Terminals

## 6 How to Programme

### 6.1 Programming with MCT 10 Setup Software

The frequency converter can be programmed from a PC via RS-485 COM port by installing the MCT 10 Setup Software. This software can either be ordered using code number 130B1000 or downloaded from the Danfoss [www.danfoss.com/BusinessAreas/DrivesSolutions/software-download](http://www.danfoss.com/BusinessAreas/DrivesSolutions/software-download) /Refer to *Motion Control Tools, MG10R*.

### 6.2 Local Control Panel (LCP)

#### 6.2.1 Local Control Panel (LCP)

The following instructions are valid for the FC 101 LCP. The LCP is divided into four functional sections.

- A. Alphanumeric display
- B. Menu key
- C. Navigation keys and indicator lights (LEDs)
- D. Operation keys and indicator lights (LEDs)

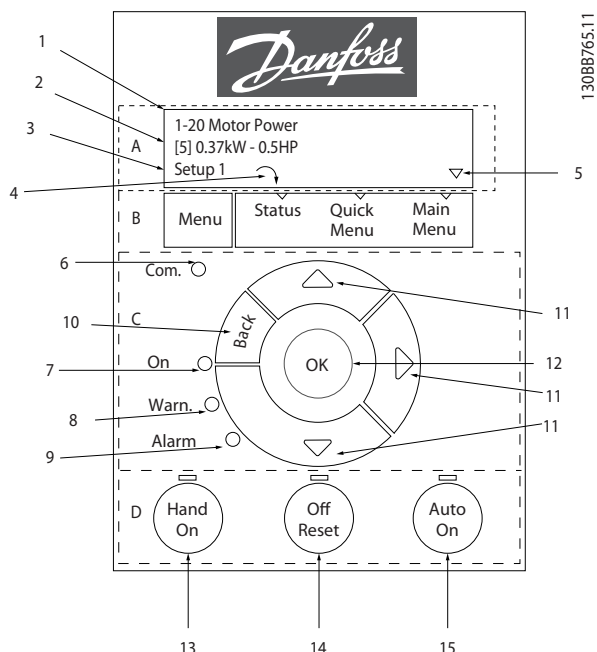

Illustration 6.1

#### A. Alpha Numeric Display

The LCD-display is back-lit with 2 alpha-numeric lines. All data is displayed on the LCP.

Information can be read from the display.

1	Parameter number and name.
2	Parameter value.
3	Set-up number shows the active set-up and the edit set-up. If the same set-up acts as both active and edit set-up, only that set-up number is shown (factory setting). When active and edit set-up differ, both numbers are shown in the display (Setup 12). The number flashing, indicates the edit set-up.
4	Motor direction is shown to the bottom left of the display – indicated by a small arrow pointing either clockwise or counterclockwise.
5	The triangle indicates if the LCP is in status, quick menu or main menu.

Table 6.1

#### B. Menu key

Use the menu key to select between status, quick menu or main menu.

#### C. Navigation keys and indicator lights (LEDs)

6	Com led: Flashes when bus communication is communicating.
7	Green LED/On: Control section is working.
8	Yellow LED/Warn.: Indicates a warning.
9	Flashing Red LED/Alarm: Indicates an alarm.
10	[Back]: For moving to the previous step or layer in the navigation structure
11	[▲] [▼] [▶]: For maneuvering between parameter groups, parameters and within parameters. Can also be used for setting local reference.
12	[OK]: For selecting a parameter and for accepting changes to parameter settings

Table 6.2

#### D. Operation keys and indicator lights (LEDs)

13	[Hand On]: Starts the motor and enables control of the frequency converter via the LCP. <b>NOTE</b> Terminal 27 Digital Input (5-12 Terminal 27 Digital Input) has coast inverse as default setting. This means that [Hand On] not starts the motor if there is no 24 V to terminal 27. Connect terminal 12 to terminal 27.
14	[Off/Reset]: Stops the motor (Off). If in alarm mode the alarm will be reset.
15	[Auto On]: frequency converter is controlled either via control terminals or serial communication.

Table 6.3

### At power-up

At the first power-up, select the preferred language. Once selected, this screen never shows again in the following powerups, but language can still be changed in 0-01 Language.

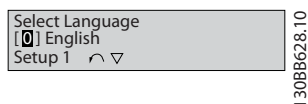

Illustration 6.2

## 6.3 Menus

### 6.3.1 Status

When choosing the [Status] menu it is possible to choose between the following:

- Motor Frequency (Hz), 16-13 Frequency
- Motor Current (A), 16-14 Motor current
- Motor Speed Reference in Percentage (%), 16-02 Reference [%]
- Feedback, 16-52 Feedback[Unit]
- Motor Power (kW) (if 0-03 Regional Settings is set to [1] North America, Motor Power is shown in the unit of hp instead of kW), 16-10 Power [kW] for kW, 16-11 Power [hp] for hp
- Custom Readout 16-09 Custom Readout

### 6.3.2 Quick Menu

Use the quick setup of the frequency converter to programme the most common VLT® HVAC Basic Drive functions. The [Quick Menu] consists of:

- Wizard for open loop applications
- Closed loop set-up wizard
- Motor set-up
- Changes made

### 6.3.3 Start-up Wizard for Open Loop Applications

The built in *wizard* menu guides the installer through the set up of the frequency converter in a clear and structured manner in order to set up an open loop application. An open loop application is here an application with a start signal, analog reference (voltage or current) and optionally also relay signals (but no feed back signal from the process applied).

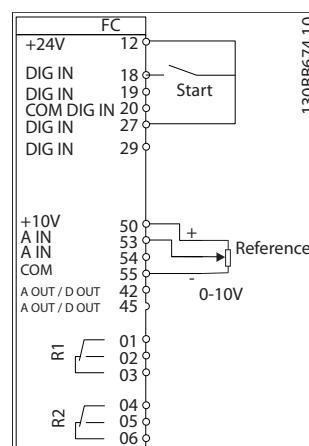

Illustration 6.3

The wizard will initially be shown after power up until any parameter has been changed. The wizard can always be accessed again through the quick menu. Press [Ok] to start the wizard. If [Back] is pressed, the FC 101 returns to the status screen.

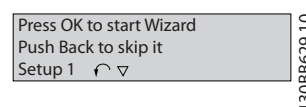

Illustration 6.4

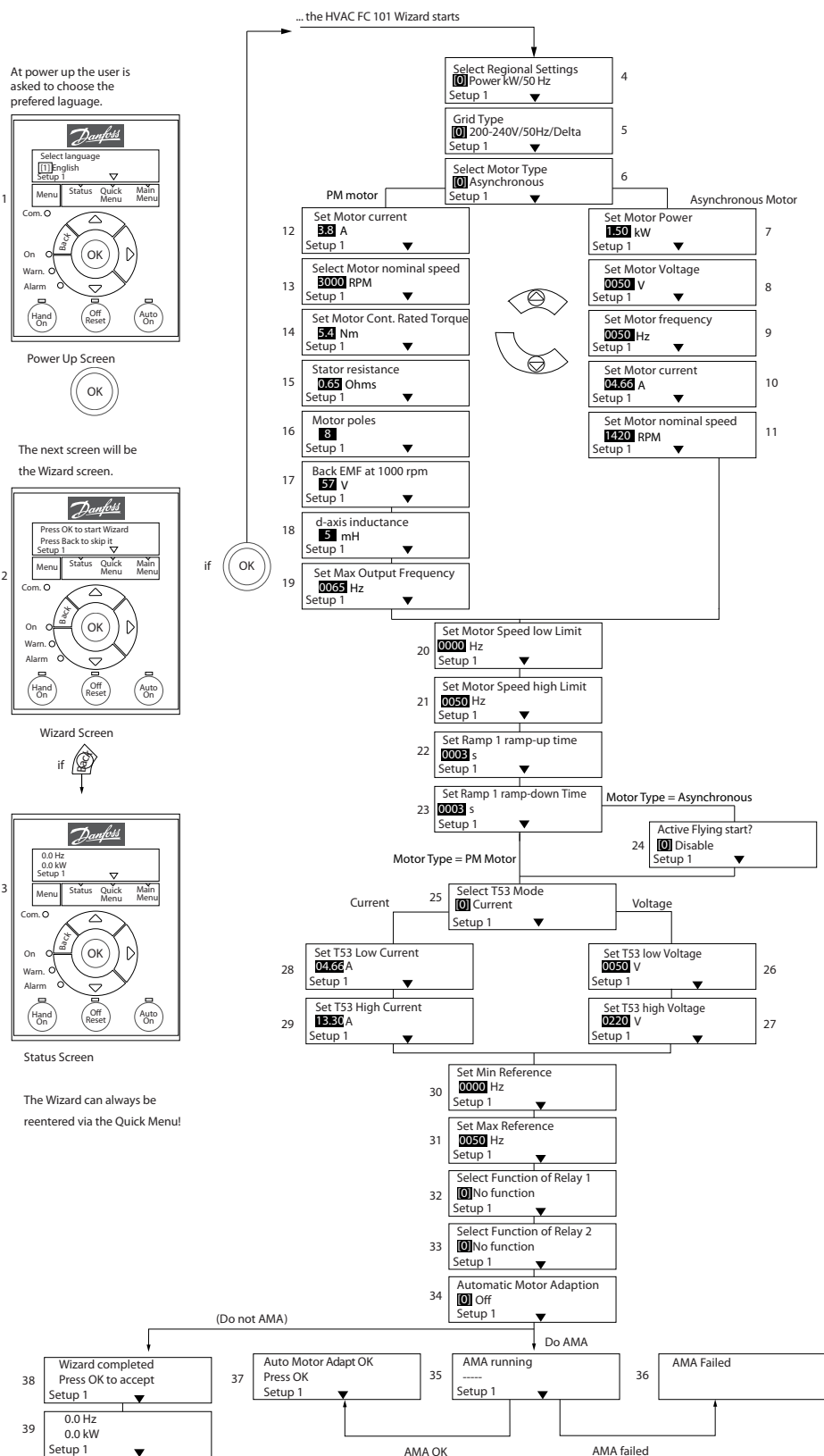

Illustration 6.5

## Start-up Wizard for Open Loop Applications

No & Name	Range	Default	Function
0-03 Regional Settings	[0] International [1] US	0	
0-06 GridType	[0] 200-240 V/50 Hz/IT-grid [1] 200-240 V/50 Hz/Delta [2] 200-240 V/50 Hz [10] 380-440 V/50 Hz/IT-grid [11] 380-440 V/50 Hz/Delta [12] 380-440 V/50 Hz [20] 440-480 V/50 Hz/IT-grid [21] 440-480 V/50 Hz/Delta [22] 440-480 V/50 Hz [30] 525-600 V/50 Hz/IT-grid [31] 525-600 V/50 Hz/Delta [32] 525-600 V/50 Hz [100] 200-240 V/60 Hz/IT-grid [101] 200-240 V/60 Hz/Delta [102] 200-240 V/60 Hz [110] 380-440 V/60 Hz/IT-grid [111] 380-440 V/60 Hz/Delta [112] 380-440 V/60 Hz [120] 440-480 V/60 Hz/IT-grid [121] 440-480 V/60 Hz/Delta [122] 440-480 V/60 Hz [130] 525-600 V/60 Hz/IT-grid [131] 525-600 V/60 Hz/Delta [132] 525-600 V/60 Hz	Size related	Select operating mode for restart upon reconnection of the drive to mains voltage after power down
1-10 Motor Construction	*[0] Asynchron [1] PM, non salient SPM	[0] Asynchron	Setting the parameter value might change these parameters: 1-01 Motor Control Principle 1-03 Torque Characteristics 1-14 Damping Gain 1-15 Low Speed Filter Time Const 1-16 High Speed Filter Time Const 1-17 Voltage filter time const 1-20 Motor Power 1-22 Motor Voltage 1-23 Motor Frequency 1-24 Motor Current 1-25 Motor Nominal Speed 1-26 Motor Cont. Rated Torque 1-30 Stator Resistance (Rs) 1-33 Stator Leakage Reactance (X1) 1-35 Main Reactance (Xh) 1-37 d-axis Inductance (Ld) 1-39 Motor Poles 1-40 Back EMF at 1000 RPM 1-66 Min. Current at Low Speed 1-72 Start Function 1-73 Flying Start 4-19 Max Output Frequency 4-58 Missing Motor Phase Function
1-20 Motor Power	0.12-110 kW/0.16-150 hp	Size related	Enter motor power from nameplate data
1-22 Motor Voltage	50.0-1000.0 V	Size related	Enter motor voltage from nameplate data
1-23 Motor Frequency	20.0-400.0 Hz	Size related	Enter motor frequency from nameplate data

No & Name	Range	Default	Function
1-24 Motor Current	0.01-10000.00 A	Size related	Enter motor current from nameplate data
1-25 Motor Nominal Speed	100.0-9999.0 RPM	Size related	Enter motor nominal speed from nameplate data
1-26 Motor Cont. Rated Torque	0.1-1000.0	Size related	This parameter is available only when <i>1-10 Motor Construction Design</i> is set to <i>[1] PM, non-salient SPM</i> . <b>NOTE</b> Changing this parameter will affect settings of other parameters
1-29 Automatic Motor Adaption (AMA)	See 1-29 Automatic Motor Adaption (AMA)	Off	Performing an AMA optimizes motor performance
1-30 Stator Resistance (Rs)	0.000-99.990	Size related	Set the stator resistance value
1-37 d-axis Inductance (Ld)	0-1000	Size related	Enter the value of the d-axis inductance. Obtain the value from the permanent magnet motor data sheet. The de-axis inductance cannot be found by performing an AMA.
1-39 Motor Poles	2-100	4	Enter the number of motor poles
1-40 Back EMF at 1000 RPM	10-9000	Size related	Line-Line RMS back EMF voltage at 1000 RPM
1-73 Flying Start			When PM is selected, Flying Start is enabled and can not disable
1-73 Flying Start	[0] Disabled [1] Enabled	0	Select <i>[1] Enable</i> to enable the drive to catch a motor spinning due to mains drop-out. Select <i>[0] Disable</i> if this function is not required. When is enabled <i>1-71 Start Delay</i> and <i>1-72 Start Function</i> have no function. is active in VVC <sup>plus</sup> mode only
3-02 Minimum Reference	-4999-4999	0	The minimum reference is the lowest value obtainable by summing all references
3-03 Maximum Reference	-4999-4999	50	The maximum reference is the lowest obtainable by summing all references
3-41 Ramp 1 Ramp Up Time	0.05-3600.0 s	Size related	Ramp up time from 0 to rated <i>1-23 Motor Frequency</i> if Asynchron motor is selected; ramp up time from 0 to <i>1-25 Motor Nominal Speed</i> if PM motor is selected
3-42 Ramp 1 Ramp Down Time	0.05-3600.0 s	Size related	Ramp down time from rated <i>1-23 Motor Frequency</i> to 0 if Asynchron motor is selected; ramp down time from <i>1-25 Motor Nominal Speed</i> to 0 if PM motor is selected
4-12 Motor Speed Low Limit [Hz]	0.0-400 Hz	0 Hz	Enter the minimum limit for low speed
4-14 Motor Speed High Limit [Hz]	0.0-400 Hz	65 Hz	Enter the maximum limit for high speed
4-19 Max Output Frequency	0-400	Size related	Enter the maximum output frequency value
5-40 Function Relay [0] Function relay	See 5-40 Function Relay	Alarm	Select the function to control output relay 1
5-40 Function Relay [1] Function relay	See 5-40 Function Relay	Drive running	Select the function to control output relay 2
6-10 Terminal 53 Low Voltage	0-10 V	0.07 V	Enter the voltage that corresponds to the low reference value
6-11 Terminal 53 High Voltage	0-10 V	10 V	Enter the voltage that corresponds to the high reference value

No & Name	Range	Default	Function
6-12 Terminal 53 Low Current	0-20 mA	4	Enter the current that corresponds to the low reference value
6-13 Terminal 53 High Current	0-20 mA	20	Enter the current that corresponds to the high reference value
6-19 Terminal 53 mode	[0] Current [1] Voltage	1	Select if terminal 53 is used for current- or voltage input

**Table 6.4**

Closed Loop Set-up Wizard

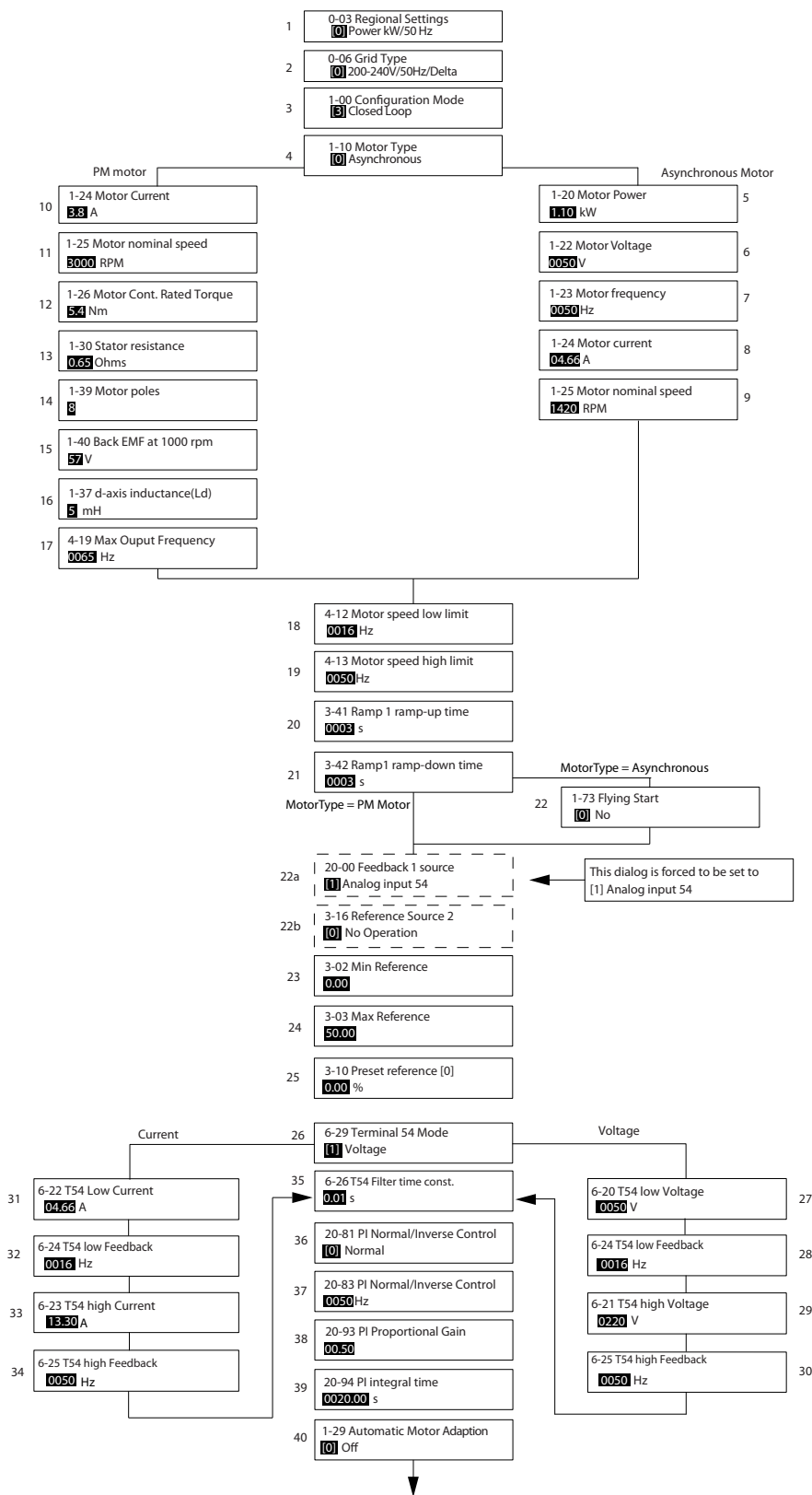

1308C402.10

Illustration 6.6



## Closed Loop Set-up Wizard

No & Name	Range	Default	Function
0-03 Regional Settings	[0] International [1] US	0	
0-06 GridType	[0] -[[132] see start -up wizard for open loop application	Size selected	Select operating mode for restart upon reconnection of the frequency converter to mains voltage after power down
1-00 Configuration Mode	[0] Open loop [3] Closed loop	0	Change this parameter to Closed loop
1-10 Motor Construction	*[0] Motor construction [1] PM, non salient SPM	[0] Asynchron	Setting the parameter value might change these parameters: 1-01 Motor Control Principle 1-03 Torque Characteristics 1-14 Damping Gain 1-15 Low Speed Filter Time Const 1-16 High Speed Filter Time Const 1-17 Voltage filter time const 1-20 Motor Power 1-22 Motor Voltage 1-23 Motor Frequency 1-25 Motor Nominal Speed 1-26 Motor Cont. Rated Torque 1-30 Stator Resistance (Rs) 1-33 Stator Leakage Reactance (X1) 1-35 Main Reactance (Xh) 1-37 d-axis Inductance (Ld) 1-39 Motor Poles 1-40 Back EMF at 1000 RPM 1-66 Min. Current at Low Speed 1-72 Start Function 1-73 Flying Start 4-19 Max Output Frequency 4-58 Missing Motor Phase Function
1-20 Motor Power	0.09-110 kW	Size related	Enter motor power from nameplate data
1-22 Motor Voltage	50.0-1000.0 V	Size related	Enter motor voltage from nameplate data
1-23 Motor Frequency	20.0-400.0 Hz	Size related	Enter motor frequency from nameplate data
1-24 Motor Current	0.0 -10000.00 A	Size related	Enter motor current from nameplate data
1-25 Motor Nominal Speed	100.0-9999.0 RPM	Size related	Enter motor nominal speed from nameplate data
1-26 Motor Cont. Rated Torque	0.1-1000.0	Size relate	This parameter is available only when <i>1-10 Motor Construction Design</i> is set to [1] <i>PM, non-salient SPM</i> . <b>NOTE</b> Changing this parameter affects settings of other parameters
1-29 Automatic Motor Adaption (AMA)		Off	Performing an AMA optimizes motor performance
1-30 Stator Resistance (Rs)	0.000-99.990	Size related	Set the stator resistance value
1-37 d-axis Inductance (Ld)	0-1000	Size related	Enter the value of the d-axis inductance. Obtain the value from the permanent magnet motor data sheet. The de-axis inductance cannot be found by performing an AMA.
1-39 Motor Poles	2-100	4	Enter the number of motor poles
1-40 Back EMF at 1000 RPM	10-9000	Size related	Line-Line RMS back EMF voltage at 1000 RPM

No & Name	Range	Default	Function
1-73 Flying Start	[0] Disabled [1] Enabled	0	Select [1] <i>Enable</i> to enable the frequency converter to catch a spinning motor. I.e. fan applications. When PM is selected, Flying Start is enabled.
3-02 Minimum Reference	-4999-4999	0	The minimum reference is the lowest value obtainable by summing all references
3-03 Maximum Reference	-4999-4999	50	The maximum reference is the highest value obtainable by summing all references
3-10 Preset Reference	-100-100%	0	Enter the set point
3-41 Ramp 1 Ramp Up Time	0.05-3600.0 s	Size related	Ramp up time from 0 to rated 1-23 <i>Motor Frequency</i> if Asynchron motor is selected; ramp up time from 0 to 1-25 <i>Motor Nominal Speed</i> if PM motor is selected"
3-42 Ramp 1 Ramp Down Time	0.05-3600.0 s	Size related	Ramp down time from rated 1-23 <i>Motor Frequency</i> to 0 if Asynchron motor is selected; ramp down time from 1-25 <i>Motor Nominal Speed</i> to 0 if PM motor is selected
4-12 Motor Speed Low Limit [Hz]	0.0-400 Hz	0.0 Hz	Enter the minimum limit for low speed
4-14 Motor Speed High Limit [Hz]	0-400 Hz	65 Hz	Enter the minimum limit for high speed
4-19 Max Output Frequency	0-400	Size related	Enter the maximum output frequency value
6-29 Terminal 54 mode	[0] Current [1] Voltage	1	Select if terminal 54 is used for current- or voltage input
6-20 Terminal 54 Low Voltage	0-10 V	0.07 V	Enter the voltage that corresponds to the low reference value
6-21 Terminal 54 High Voltage	0-10 V	10 V	Enter the voltage that corresponds to the low high reference value
6-22 Terminal 54 Low Current	0-20 mA	4	Enter the current that corresponds to the high reference value
6-23 Terminal 54 High Current	0-20 mA	20	Enter the current that corresponds to the high reference value
6-24 Terminal 54 Low Ref./Feedb. Value	-4999-4999	0	Enter the feedback value that corresponds to the voltage or current set in 6-20 <i>Terminal 54 Low Voltage</i> /6-22 <i>Terminal 54 Low Current</i>
6-25 Terminal 54 High Ref./Feedb. Value	-4999-4999	50	Enter the feedback value that corresponds to the voltage or current set in 6-21 <i>Terminal 54 High Voltage</i> /6-23 <i>Terminal 54 High Current</i>
6-26 Terminal 54 Filter Time Constant	0-10 s	0.01	Enter the filter time constant
20-81 PI Normal/ Inverse Control	[0] Normal [1] Inverse	0	Select [0] <i>Normal</i> to set the process control to increase the output speed when the process error is positive. Select [1] <i>Inverse</i> to reduce the output speed.
20-83 PI Start Speed [Hz]	0-200 Hz	0	Enter the motor speed to be attained as a start signal for commencement of PI control
20-93 PI Proportional Gain	0-10	0.01	Enter the process controller proportional gain. Quick control is obtained at high amplification. However if amplification is too great, the process may become unstable
20-94 PI Integral Time	0.1-999.0 s	999.0 s	Enter the process controller integral time. Obtain quick control through a short integral time, though if the integral time is too short, the process becomes unstable. An excessively long integral time disables the integral action.

Table 6.5

**Motor Set-up**

The Quick Menu Motor Set-up guides through the needed motor parameters.

6

No & Name	Range	Default	Function
0-03 Regional Settings	[0] International [1] US	0	
0-06 GridType	[0] -[132] see start -up wizard for open loop application	Size selected	Select operating mode for restart upon reconnection of the drive to mains voltage after power down
1-10 Motor Construction	*[0] Motor construction [1] PM, non salient SPM	[0] Asynchron	
1-20 Motor Power	0.12-110 kW/ 0.16-150 hp	Size related	Enter motor power from nameplate data
1-22 Motor Voltage	50.0-1000.0 V	Size related	Enter motor voltage from nameplate data
1-23 Motor Frequency	20.0-400.0 Hz	Size related	Enter motor frequency from nameplate data
1-24 Motor Current	0.01-10000.00 A	Size related	Enter motor current from nameplate data
1-25 Motor Nominal Speed	100.0-9999.0 RPM	Size related	Enter motor nominal speed from nameplate data
1-26 Motor Cont. Rated Torque	0.1-1000.0	Size related	This parameter is available only when <i>1-10 Motor Construction</i> Design is set to <i>[1] PM, non-salient SPM.</i> <b>NOTE</b> Changing this parameter affects settings of other parameters
1-30 Stator Resistance (Rs)	0.000-99.990	Size related	Set the stator resistance value

No & Name	Range	Default	Function
1-37 d-axis Inductance (Ld)	0-1000	Size related	Enter the value of the d-axis inductance. Obtain the value from the permanent magnet motor data sheet. The de-axis inductance cannot be found by performing an AMA.
1-39 Motor Poles	2-100	4	Enter the number of motor poles
1-40 Back EMF at 1000 RPM	10-9000	Size related	Line-Line RMS back EMF voltage at 1000 RPM
1-73 Flying Start	[0] Disabled [1] Enabled	0	Select Enable to enable the frequency converter to catch a spinning motor
3-41 Ramp 1 Ramp Up Time	0.05-3600.0 s	Size related	Ramp up time from 0 to rated <i>1-23 Motor Frequency</i>
3-42 Ramp 1 Ramp Down Time	0.05-3600.0 s	Size related	Ramp down time from rated <i>1-23 Motor Frequency</i> to 0
4-12 Motor Speed Low Limit [Hz]	0.0-400 Hz	0.0 Hz	Enter the minimum limit for low speed
4-14 Motor Speed High Limit [Hz]	0.0-400 Hz	65	Enter the maximum limit for high speed
4-19 Max Output Frequency	0-400	Size related	Enter the maximum output frequency value

Table 6.6

### Changes Made

Changes Made lists all parameters changed since factory setting. Only the changed parameters in current edit-setup are listed in changes made.

If the parameter's value is changed back to factory setting's value from another different value, the parameter will NOT be listed in *Changes Made*.

1. Press [Menu] to enter the Quick Menu until indicator in display is placed above Quick Menu.
2. Press [▲] [▼] to select either FC 101 wizard, closed loop setup, motor setup or changes made, then press [OK].
3. Press [▲] [▼] to browse through the parameters in the Quick Menu.
4. Press [Ok] to select a parameter.
5. Press [▲] [▼] to change the value of a parameter setting.
6. Press [Ok] to accept the change.
7. Press either [Back] twice to enter "Status", or press [Menu] once to enter "Main Menu".

#### 6.3.4 Main Menu

[Main Menu] is used for programming all parameters. The Main Menu parameters can be accessed immediately unless a password has been created via *0-60 Main Menu Password*. For the majority of VLT® HVAC Basic Drive applications it is not necessary to access the Main Menu parameters but instead the Quick Menu provides the simplest and quickest access to the typical required parameters.

The Main Menu accesses all parameters.

1. Press [Menu] until indicator in display is placed above "Main Menu".
2. Use [▲] [▼] to browse through the parameter groups.
3. Press [Ok] to select a parameter group.
4. Use [▲] [▼] to browse through the parameters in the specific group.
5. Press [Ok] to select the parameter.
6. Use [▲] [▼] to set/change the parameter value.

[Back] is used to go one level back.

#### 6.4 Quick Transfer of Parameter Settings between Multiple Frequency Converters

Once the set-up of a frequency converter is complete, Danfoss recommends to store the data in the LCP or on a PC via MCT 10 Setup Software tool.

Data storage in LCP.

### **WARNING**

**Stop the motor before performing this operation.**

1. Go to *0-50 LCP Copy*
2. Press the [Ok] key
3. Select "All to LCP"
4. Press the [Ok] key

Connect the LCP to another frequency converter and copy the parameter settings to this frequency converter as well.

Data transfer from LCP to frequency converter:

### **NOTE**

**Stop the motor before performing this operation.**

1. Go to *0-50 LCP Copy*
2. Press the [Ok] key
3. Select "All from LCP"
4. Press the [Ok] key

#### 6.5 Read-out and Programming of Indexed Parameters

Use as an example.

Choose the parameter, press [Ok], and press [▲]/[▼] to scroll through the indexed values. To change the parameter value, select the indexed value and press [Ok]. Change the value by pressing [▲]/[▼]. Press [Ok] to accept the new setting. Press [Cancel] to abort. Press [Back] to leave the parameter.

15-05 Over Volt's

15-4\* Drive identification parameters

Initialisation of parameters is confirmed by AL80 in the display after the power cycle.

## 6.6 Initialise the Frequency Converter to Default Settings in two Ways

Recommended initialisation (via 14-22 Operation Mode)

1. Select *14-22 Operation Mode*.
2. Press [Ok].
3. Select *Initialisation* and Press [Ok].
4. Cut off the mains supply and wait until the display turns off.
5. Reconnect the mains supply - the frequency converter is now reset. *Except the following parameters.*

*8-30 Protocol*

*8-31 Address*

*8-32 Baud Rate*

*8-33 Parity / Stop Bits*

*8-35 Minimum Response Delay*

*8-36 Maximum Response Delay*

*8-37 Maximum Inter-char delay*

*8-70 BACnet Device Instance*

*8-72 MS/TP Max Masters*

*8-73 MS/TP Max Info Frames*

*8-74 "I am" Service*

*8-75 Intialisation Password*

*15-00 Operating hours to 15-05 Over Volt's*

*15-03 Power Up's*

*15-04 Over Temp's*

*15-05 Over Volt's*

*15-30 Alarm Log: Error Code*

*15-4\* Drive identification parameters*

*1-06 Clockwise Direction*

### Two finger initialization:

1. Power off the frequency converter.
2. Press [Ok] and [Menu].
3. Power up the frequency converter while still pressing the keys above for 10 s.
4. The frequency converter is now reset, except the following parameters:

*15-00 Operating hours*

*15-03 Power Up's*

*15-04 Over Temp's*

## 7 RS-485 Installation and Set-up

### 7.1.1 Overview

RS-485 is a two-wire bus interface compatible with multi-drop network topology, that is, nodes can be connected as a bus, or via drop cables from a common trunk line. A total of 32 nodes can be connected to one network segment.

Repeaters divide network segments.

### NOTE

**Each repeater functions as a node within the segment in which it is installed. Each node connected within a given network must have a unique node address, across all segments.**

Terminate each segment at both ends, using either the termination switch (S801) of the frequency converters or a biased termination resistor network. Always use screened twisted pair (STP) cable for bus cabling, and always follow good common installation practice.

Low-impedance earth connection of the screen at every node is important, including at high frequencies. Thus, connect a large surface of the screen to earth, for example with a cable clamp or a conductive cable gland. It may be necessary to apply potential-equalizing cables to maintain the same earth potential throughout the network - particularly in installations with long cables.

To prevent impedance mismatch, always use the same type of cable throughout the entire network. When connecting a motor to the frequency converter, always use screened motor cable.

Cable	Screened twisted pair (STP)
Impedance	120 Ω
Cable length	Max. 1200 m (including drop lines) Max. 500 m station-to-station

Table 7.1

### 7.1.2 Network Connection

**Connect the frequency converter to the RS-485 network as follows (see also diagram):**

1. Connect signal wires to terminal 68 (P+) and terminal 69 (N-) on the main control board of the frequency converter.
2. Connect the cable screen to the cable clamps.

### NOTE

**Screened, twisted-pair cables are recommended in order to reduce noise between conductors.**

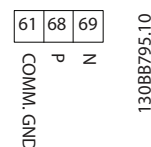

Illustration 7.1

### 7.1.3 Frequency Converter Hardware Set-up

Use the terminator dip switch on the main control board of the frequency converter to terminate the RS-485 bus.

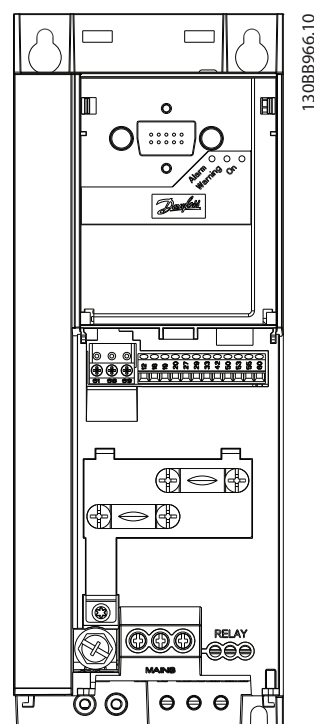

Illustration 7.2 Terminator Switch Factory Setting

The factory setting for the dip switch is OFF.

## 7.1.4 Frequency Converter Parameter Settings for Modbus Communication

The following parameters apply to the RS-485 interface (FC-port):

Parameter	Function
8-30 Protocol	Select the application protocol to run on the RS-485 interface
8-31 Address	Set the node address. <b>NOTE</b> The address range depends on the protocol selected in 8-30 Protocol
8-32 Baud Rate	Set the baud rate. <b>NOTE</b> The default baud rate depends on the protocol selected in 8-30 Protocol
8-33 Parity / Stop Bits	Set the parity and number of stop bits. <b>NOTE</b> The default selection depends on the protocol selected in 8-30 Protocol
8-35 Minimum Response Delay	Specify a minimum delay time between receiving a request and transmitting a response. This function is for overcoming modem turnaround delays.
8-36 Maximum Response Delay	Specify a maximum delay time between transmitting a request and receiving a response.
8-37 Maximum Inter-char delay	If transmission is interrupted, specify a maximum delay time between two received bytes to ensure time-out.

Table 7.2

## 7.1.5 EMC Precautions

To achieve interference-free operation of the RS-485 network, Danfoss recommends the following EMC precautions.

Relevant national and local regulations, for example regarding protective earth connection, must be observed. To avoid coupling of high frequency noise between the cables, the RS-485 communication cable must be kept away from motor and brake resistor cables. Normally a distance of 200 mm (8 inches) is sufficient, but Danfoss recommends keeping the greatest possible distance between the cables. Especially where cables run in parallel over long distances. When crossing is unavoidable, the RS-485 cable must cross motor and brake resistor cables at an angle of 90°.

## 7.2 FC Protocol Overview

The FC protocol, also referred to as FC bus or Standard bus, is the Danfoss standard fieldbus. It defines an access technique according to the master-slave principle for communications via a serial bus.

One master and a maximum of 126 slaves can be connected to the bus. The master selects the individual slaves via an address character in the telegram. A slave itself can never transmit without first being requested to do so, and direct message transfer between the individual slaves is not possible. Communications occur in the half-duplex mode.

The master function cannot be transferred to another node (single-master system).

The physical layer is RS-485, thus utilizing the RS-485 port built into the frequency converter. The FC protocol supports different telegram formats:

- A short format of 8 bytes for process data.
- A long format of 16 bytes that also includes a parameter channel.
- A format used for texts.

### 7.2.1 FC with Modbus RTU

The FC protocol provides access to the Control Word and Bus Reference of the frequency converter.

The Control Word allows the Modbus master to control several important functions of the frequency converter.

- Start
- Stop of the frequency converter in various ways:
  - Coast stop
  - Quick stop
  - DC Brake stop
  - Normal (ramp) stop
- Reset after a fault trip
- Run at various preset speeds
- Run in reverse
- Change of the active set-up
- Control of the 2 relays built into the frequency converter

The Bus Reference is commonly used for speed control. It is also possible to access the parameters, read their values, and where possible, write values to them. This permits a range of control options, including controlling the setpoint

of the frequency converter when its internal PI controller is used.

## 7.3 Network Configuration

### 7.3.1 Frequency Converter Set-up

Set the following parameters to enable the FC protocol for the frequency converter.

Parameter	Setting
8-30 Protocol	FC
8-31 Address	1-126
8-32 Baud Rate	2400-115200
8-33 Parity / Stop Bits	Even parity, 1 stop bit (default)

Table 7.3

## 7.4 FC Protocol Message Framing Structure

### 7.4.1 Content of a Character (byte)

Each character transferred begins with a start bit. Then 8 data bits are transferred, corresponding to a byte. Each character is secured via a parity bit. This bit is set at "1" when it reaches parity. Parity is when there is an equal number of 1s in the 8 data bits and the parity bit in total. A stop bit completes a character, thus consisting of 11 bits in all.

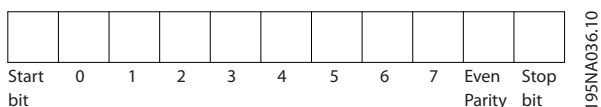

Illustration 7.3

### 7.4.2 Telegram Structure

Each telegram has the following structure:

1. Start character (STX)=02 Hex
2. A byte denoting the telegram length (LGE)
3. A byte denoting the frequency converter address (ADR)

A number of data bytes (variable, depending on the type of telegram) follows.

A data control byte (BCC) completes the telegram.

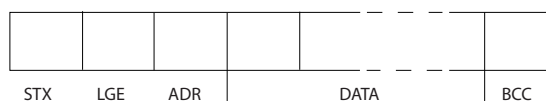

Illustration 7.4

### 7.4.3 Telegram Length (LGE)

The telegram length is the number of data bytes plus the address byte ADR and the data control byte BCC.

4 data bytes	LGE=4+1+1=6 bytes
12 data bytes	LGE=12+1+1=14 bytes
Telegrams containing texts	10 <sup>1</sup> +n bytes

Table 7.4 Length of telegrams

<sup>1)</sup> The 10 represents the fixed characters, while the "n" is variable (depending on the length of the text).

### 7.4.4 Frequency Converter Address (ADR)

#### Address format 1-126

- Bit 7=1 (address format 1-126 active)
- Bit 0-6=frequency converter address 1-126
- Bit 0-6=0 Broadcast

The slave returns the address byte unchanged to the master in the response telegram.

### 7.4.5 Data Control Byte (BCC)

The checksum is calculated as an XOR-function. Before the first byte in the telegram is received, the Calculated Checksum is 0.

### 7.4.6 The Data Field

The structure of data blocks depends on the type of telegram. There are three telegram types, and the type applies for both control telegrams (master⇒slave) and response telegrams (slave⇒master).

The 3 types of telegram are:

#### Process block (PCD)

The PCD is made up of a data block of 4 bytes (2 words) and contains:

- Control word and reference value (from master to slave)
- Status word and present output frequency (from slave to master)



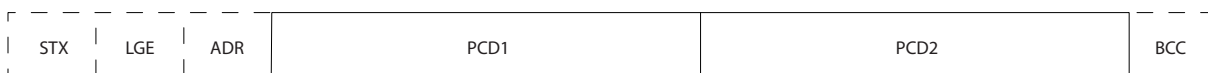

130BA269.10

Illustration 7.5

### Parameter block

The parameter block is used to transfer parameters between master and slave. The data block is made up of 12 bytes (6 words) and also contains the process block.

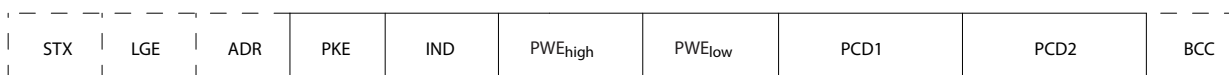

130BA271.10

Illustration 7.6

# 7

### Text block

The text block is used to read or write texts via the data block.

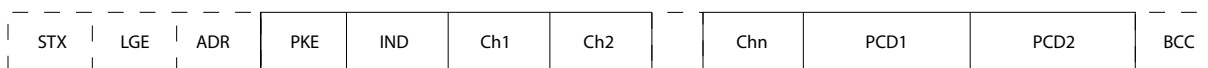

130BA270.10

Illustration 7.7

## 7.4.7 The PKE Field

The PKE field contains two subfields: Parameter command and response (AK) and Parameter number (PNU):

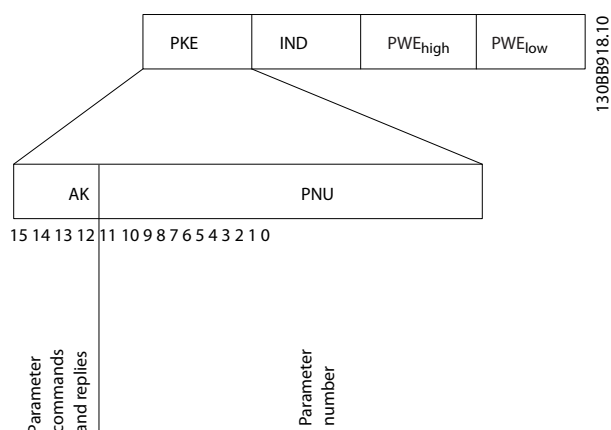

130BB918.10

Illustration 7.8

Bits no. 12-15 transfer parameter commands from master to slave and return processed slave responses to the master.

Parameter commands master ⇒ slave				
Bit no.				Parameter command
15	14	13	12	
0	0	0	0	No command
0	0	0	1	Read parameter value
0	0	1	0	Write parameter value in RAM (word)
0	0	1	1	Write parameter value in RAM (double word)
1	1	0	1	Write parameter value in RAM and EEPROM (double word)
1	1	1	0	Write parameter value in RAM and EEPROM (word)
1	1	1	1	Read text

Table 7.5

Response slave ⇒ master				
Bit no.				Response
15	14	13	12	
0	0	0	0	No response
0	0	0	1	Parameter value transferred (word)
0	0	1	0	Parameter value transferred (double word)
0	1	1	1	Command cannot be performed
1	1	1	1	text transferred

Table 7.6

If the command cannot be performed, the slave sends this response:

*0111 Command cannot be performed*

- and issues the following fault report in the parameter value:

Error code	FC+ Specification
0	Illegal Parameter Number
1	Parameter cannot be changed.
2	Upper or lower limit exceeded
3	Subindex corrupted
4	No Array
5	Wrong Data Type
6	Not used
7	Not used
9	Description element not available
11	No parameter write access
15	No text available
17	Not while Running
18	Other error
100	
>100	
130	No bus access for this parameter
131	Write to factory set-up not possible
132	No LCP access
252	Unknown viewer
253	Request not supported
254	Unknown attribute
255	No error

Table 7.7

### 7.4.8 Parameter Number (PNU)

Bits no. 0-11 transfer parameter numbers. The function of the relevant parameter is defined in the parameter description in *6 How to Programme*.

### 7.4.9 Index (IND)

The index is used together with the parameter number to read/write-access parameters with an index, for example, *15-30 Alarm Log: Error Code*. The index consists of 2 bytes; a low byte, and a high byte.

Only the low byte is used as an index.

### 7.4.10 Parameter Value (PWE)

The parameter value block consists of 2 words (4 bytes), and the value depends on the defined command (AK). The master prompts for a parameter value when the PWE block contains no value. To change a parameter value (write),

write the new value in the PWE block and send from the master to the slave.

When a slave responds to a parameter request (read command), the present parameter value in the PWE block is transferred and returned to the master. If a parameter contains several data options, e.g. *0-01 Language*, select the data value by entering the value in the PWE block. Serial communication is only capable of reading parameters containing data type 9 (text string).

*15-40 FC Type* to *15-53 Power Card Serial Number* contain data type 9.

For example, read the unit size and mains voltage range in *15-40 FC Type*. When a text string is transferred (read), the length of the telegram is variable, and the texts are of different lengths. The telegram length is defined in the second byte of the telegram (LGE). When using text transfer, the index character indicates whether it is a read or a write command.

To read a text via the PWE block, set the parameter command (AK) to 'F' Hex. The index character high-byte must be "4".

### 7.4.11 Data Types Supported by the Frequency Converter

Unsigned means that there is no operational sign in the telegram.

Data types	Description
3	Integer 16
4	Integer 32
5	Unsigned 8
6	Unsigned 16
7	Unsigned 32
9	Text string

Table 7.8

### 7.4.12 Conversion

The various attributes of each parameter are displayed in the section *Factory Settings*. Parameter values are transferred as whole numbers only. Conversion factors are therefore used to transfer decimals.

*4-12 Motor Speed Low Limit [Hz]* has a conversion factor of 0.1.

To preset the minimum frequency to 10 Hz, transfer the value 100. A conversion factor of 0.1 means that the value transferred is multiplied by 0.1. The value 100 is thus perceived as 10.0.

Conversion index	Conversion factor
74	0.1
2	100
1	10
0	1
-1	0.1
-2	0.01
-3	0.001
-4	0.0001
-5	0.00001

Table 7.9

### 7.4.13 Process Words (PCD)

The block of process words is divided into two blocks of 16 bits, which always occur in the defined sequence.

PCD 1	PCD 2
Control telegram (master⇒slave Control word)	Reference-value
Control telegram (slave⇒master) Status word	Present output frequency

Table 7.10

## 7.5 Examples

### 7.5.1 Writing a Parameter Value

Change 4-14 Motor Speed High Limit [Hz] to 100 Hz. Write the data in EEPROM.

PKE=E19E Hex - Write single word in 4-14 Motor Speed High Limit [Hz]:

IND=0000 Hex

PWEHIGH=0000 Hex

PWELOW=03E8 Hex

Data value 1000, corresponding to 100 Hz, see 7.4.12 Conversion.

The telegram looks like this:

E19E	H	0000	H	0000	H	03E8	H
PKE		IND		PWE <sub>high</sub>		PWE <sub>low</sub>	

Illustration 7.9

130BA092.10

## NOTE

4-14 Motor Speed High Limit [Hz] is a single word, and the parameter command for write in EEPROM is "E". Parameter 4-14 is 19E in hexadecimal.

The response from the slave to the master is:

119E	H	0000	H	0000	H	03E8	H
PKE		IND		PWE <sub>high</sub>		PWE <sub>low</sub>	

Illustration 7.10

130BA093.10

### 7.5.2 Reading a Parameter Value

Read the value in 3-41 Ramp 1 Ramp Up Time

PKE=1155 Hex - Read parameter value in 3-41 Ramp 1 Ramp Up Time  
 IND=0000 Hex  
 PWE<sub>HIGH</sub>=0000 Hex  
 PWE<sub>LOW</sub>=0000 Hex

1155	H	0000	H	0000	H	0000	H
PKE		IND		PWE <sub>high</sub>		PWE <sub>low</sub>	

Illustration 7.11

130BA094.10

If the value in 3-41 Ramp 1 Ramp Up Time is 10 s, the response from the slave to the master is:

1155	H	0000	H	0000	H	03E8	H
PKE		IND		PWE <sub>high</sub>		PWE <sub>low</sub>	

Illustration 7.12

130BA267.10

3E8 Hex corresponds to 1000 decimal. The conversion index for 3-41 Ramp 1 Ramp Up Time is -2, that is, 0.01. 3-41 Ramp 1 Ramp Up Time is of the type Unsigned 32.

## 7.6 Modbus RTU Overview

### 7.6.1 Assumptions

Danfoss assumes that the installed controller supports the interfaces in this document, and strictly observe all requirements and limitations stipulated in the controller and frequency converter.

## 7.6.2 What the User Should Already Know

The Modbus RTU (Remote Terminal Unit) is designed to communicate with any controller that supports the interfaces defined in this document. It is assumed that the user has full knowledge of the capabilities and limitations of the controller.

## 7.6.3 Modbus RTU Overview

Regardless of the type of physical communication networks, the Modbus RTU Overview describes the process a controller uses to request access to another device. This process includes how the Modbus RTU responds to requests from another device, and how errors are detected and reported. It also establishes a common format for the layout and contents of message fields.

During communications over a Modbus RTU network, the protocol determines:

- How each controller learns its device address
- Recognizes a message addressed to it
- Determines which actions to take
- Extracts any data or other information contained in the message

If a reply is required, the controller constructs the reply message and sends it.

Controllers communicate using a master-slave technique in which only one device (the master) can initiate transactions (called queries). The other devices (slaves) respond by supplying the requested data to the master, or by taking the action requested in the query.

The master can address individual slaves, or can initiate a broadcast message to all slaves. Slaves return a message (called a response) to queries that are addressed to them individually. No responses are returned to broadcast queries from the master. The Modbus RTU protocol establishes the format for the master's query by placing into it the device (or broadcast) address, a function code defining the requested action, any data to be sent, and an error-checking field. The slave's response message is also constructed using Modbus protocol. It contains fields confirming the action taken, any data to be returned, and an error-checking field. If an error occurs in receipt of the message, or if the slave is unable to perform the requested action, the slave constructs an error message, and send it in response, or a time-out occurs.

## 7.6.4 Frequency Converter with Modbus RTU

The frequency converter communicates in Modbus RTU format over the built-in RS-485 interface. Modbus RTU provides access to the Control Word and Bus Reference of the frequency converter.

The Control Word allows the Modbus master to control several important functions of the frequency converter:

- Start
- Stop of the frequency converter in various ways:
  - Coast stop
  - Quick stop
  - DC Brake stop
  - Normal (ramp) stop
- Reset after a fault trip
- Run at a variety of preset speeds
- Run in reverse
- Change the active set-up
- Control the frequency converter's built-in relay

The Bus Reference is commonly used for speed control. It is also possible to access the parameters, read their values, and where possible, write values to them. This permits a range of control options, including controlling the setpoint of the frequency converter when its internal PI controller is used.

## 7.7 Network Configuration

To enable Modbus RTU on the frequency converter, set the following parameters:

Parameter	Setting
8-30 Protocol	Modbus RTU
8-31 Address	1-247
8-32 Baud Rate	2400-115200
8-33 Parity / Stop Bits	Even parity, 1 stop bit (default)

Table 7.11

## 7.8 Modbus RTU Message Framing Structure

### 7.8.1 Frequency Converter with Modbus RTU

The controllers are set up to communicate on the Modbus network using RTU (Remote Terminal Unit) mode, with each byte in a message containing 2 4-bit hexadecimal characters. The format for each byte is shown in *Table 7.12*.

Start bit	Data byte							Stop/parity	Stop

**Table 7.12 Format for Each Byte**

Coding System	8-bit binary, hexadecimal 0-9, A-F. 2 hexadecimal characters contained in each 8-bit field of the message
Bits Per Byte	1 start bit 8 data bits, least significant bit sent first 1 bit for even/odd parity; no bit for no parity 1 stop bit if parity is used; 2 bits if no parity
Error Check Field	Cyclical Redundancy Check (CRC)

**Table 7.13**
**7**

## 7.8.2 Modbus RTU Message Structure

The transmitting device places a Modbus RTU message into a frame with a known beginning and ending point. This allows receiving devices to begin at the start of the message, read the address portion, determine which device is addressed (or all devices, if the message is broadcast), and to recognise when the message is completed. Partial messages are detected and errors set as a result. Characters for transmission must be in hexadecimal 00 to FF format in each field. The frequency converter continuously monitors the network bus, also during 'silent' intervals. When the first field (the address field) is received, each frequency converter or device decodes it to determine which device is being addressed. Modbus RTU messages addressed to zero are broadcast messages. No response is permitted for broadcast messages. A typical message frame is shown in *Table 7.14*.

Start	Address	Function	Data	CRC check	End
T1-T2-T3-T4	8 bits	8 bits	N x 8 bits	16 bits	T1-T2-T3-T4

**Table 7.14 Typical Modbus RTU Message Structure**

### 7.8.3 Start/Stop Field

Messages start with a silent period of at least 3.5 character intervals. This is implemented as a multiple of character intervals at the selected network baud rate (shown as Start T1-T2-T3-T4). The first field to be transmitted is the device address. Following the last transmitted character, a similar period of at least 3.5 character intervals marks the end of the message. A new message can begin after this period. The entire message frame must be transmitted as a continuous stream. If a silent period of more than 1.5 character intervals occurs before completion of the frame, the receiving device flushes the incomplete message and

assumes that the next byte is the address field of a new message. Similarly, if a new message begins prior to 3.5 character intervals after a previous message, the receiving device will consider it a continuation of the previous message. This causes a time-out (no response from the slave), since the value in the final CRC field is not valid for the combined messages.

### 7.8.4 Address Field

The address field of a message frame contains 8 bits. Valid slave device addresses are in the range of 0-247 decimal. The individual slave devices are assigned addresses in the range of 1-247. (0 is reserved for broadcast mode, which all slaves recognize.) A master addresses a slave by placing the slave address in the address field of the message. When the slave sends its response, it places its own address in this address field to let the master know which slave is responding.

### 7.8.5 Function Field

The function field of a message frame contains 8 bits. Valid codes are in the range of 1-FF. Function fields are used to send messages between master and slave. When a message is sent from a master to a slave device, the function code field tells the slave what kind of action to perform. When the slave responds to the master, it uses the function code field to indicate either a normal (error-free) response, or that some kind of error occurred (called an exception response). For a normal response, the slave simply echoes the original function code. For an exception response, the slave returns a code that is equivalent to the original function code with its most significant bit set to logic 1. In addition, the slave places a unique code into the data field of the response message. This tells the master what kind of error occurred, or the reason for the exception. Please also refer to *7.8.10 Function Codes Supported by Modbus RTU* and *7.8.11 Modbus Exception Codes*.

### 7.8.6 Data Field

The data field is constructed using sets of two hexadecimal digits, in the range of 00 to FF hexadecimal. These are made up of one RTU character. The data field of messages sent from a master to slave device contains additional information which the slave must use to take the action defined by the function code. This can include items such as coil or register addresses, the quantity of items to be handled, and the count of actual data bytes in the field.

### 7.8.7 CRC Check Field

Messages include an error-checking field, operating based on a Cyclical Redundancy Check (CRC) method. The CRC field checks the contents of the entire message. It is applied regardless of any parity check method used for the individual characters of the message. The CRC value is calculated by the transmitting device, which appends the CRC as the last field in the message. The receiving device recalculates a CRC during receipt of the message and compares the calculated value to the actual value received in the CRC field. If the two values are unequal, a bus time-out results. The error-checking field contains a 16-bit binary value implemented as two 8-bit bytes. When this is done, the low-order byte of the field is appended first, followed by the high-order byte. The CRC high-order byte is the last byte sent in the message.

### 7.8.8 Coil Register Addressing

In Modbus, all data are organized in coils and holding registers. Coils hold a single bit, whereas holding registers hold a 2-byte word (that is, 16 bits). All data addresses in Modbus messages are referenced to zero. The first occurrence of a data item is addressed as item number zero. For example: The coil known as 'coil 1' in a programmable controller is addressed as coil 0000 in the data address field of a Modbus message. Coil 127 decimal is addressed as coil 007EHEX (126 decimal).

Holding register 40001 is addressed as register 0000 in the data address field of the message. The function code field already specifies a 'holding register' operation. Therefore, the '4XXXX' reference is implicit. Holding register 40108 is addressed as register 006BHEX (107 decimal).

Coil Number	Description	Signal Direction
1-16	Frequency converter control word (see <i>Table 7.16</i> )	Master to slave
17-32	Frequency converter speed or set-point reference Range 0x0-0xFFFF (-200% ... -200%)	Master to slave
33-48	Frequency converter status word (see <i>Table 7.16</i> and <i>Table 7.17</i> )	Slave to master
49-64	Open loop mode: Frequency converter output frequency Closed loop mode: Frequency converter feedback signal	Slave to master
65	Parameter write control (master to slave)	Master to slave
	0= Parameter changes are written to the RAM of the frequency converter	
	1= Parameter changes are written to the RAM and EEPROM of the frequency converter.	
66-65536	Reserved	

**Table 7.15**

Coil	0	1
01	Preset reference LSB	
02	Preset reference MSB	
03	DC brake	No DC brake
04	Coast stop	No coast stop
05	Quick stop	No quick stop
06	Freeze freq.	No freeze freq.
07	Ramp stop	Start
08	No reset	Reset
09	No jog	Jog
10	Ramp 1	Ramp 2
11	Data not valid	Data valid
12	Relay 1 off	Relay 1 on
13	Relay 2 off	Relay 2 on
14	Set up LSB	
15		
16	No reversing	Reversing

**Table 7.16 Frequency Converter Control Word (FC Profile)**

Coil	0	1
33	Control not ready	Control ready
34	Frequency converter not ready	Frequency converter ready
35	Coasting stop	Safety closed
36	No alarm	Alarm
37	Not used	Not used
38	Not used	Not used
39	Not used	Not used
40	No warning	Warning
41	Not at reference	At reference
42	Hand mode	Auto mode
43	Out of freq. range	In frequency range
44	Stopped	Running
45	Not used	Not used
46	No voltage warning	Voltage warning
47	Not in current limit	Current limit
48	No thermal warning	Thermal warning

Table 7.17 Frequency Converter Status Word (FC Profile)

Bus adress	Bus register <sup>1</sup>	PLC Register	Content	Access	Description
0	1	40001	Reserved		Reserved for Legacy Drives VLT 5000 and VLT 2800
1	2	40002	Reserved		Reserved for Legacy Drives VLT 5000 and VLT 2800
2	3	40003	Reserved		Reserved for Legacy Drives VLT 5000 and VLT 2800
3	4	40004	Free		
4	5	40005	Free		
5	6	40006	Modbus conf	Read/Write	TCP only. Reserved for Modbus TCP (p12-28 and 12-29 - store in Eeprom etc.)
6	7	40007	Last error code	Read only	Error code recieved from parameter database, refer to WHAT 38295 for details
7	8	40008	Last error register	Read only	Address of register with which last error occurred, refer to WHAT 38296 for details
8	9	40009	Index pointer	Read/Write	Sub index of parameter to be accessed. Refer to WHAT 38297 for details
9	10	40010	FC par. 0-01	Dependent on parameter access	Parameter 0-01 (Modbus Register=10 parameter number 20 bytes space reserved pr parameter in Modbus Map
19	20	40020	FC par. 0-02	Dependent on parameter access	Parameter 0-02 20 bytes space reserved pr parameter in Modbus Map
29	30	40030	FC par. xx-xx	Dependent on parameter access	Parameter 0-03 20 bytes space reserved pr parameter in Modbus Map

Table 7.18

<sup>1)</sup> Value written in Modbus RTU telegram must be one or less than register number. E.g. Read Modbus Register 1 by writing value 0 in telegram.

## 7.8.9 How to Control the Frequency Converter

This section describes codes which can be used in the function and data fields of a Modbus RTU message.

### 7.8.10 Function Codes Supported by Modbus RTU

Modbus RTU supports use of the following function codes in the function field of a message.

Function	Function Code
Read coils	1 hex
Read holding registers	3 hex
Write single coil	5 hex
Write single register	6 hex
Write multiple coils	F hex
Write multiple registers	10 hex
Get comm. event counter	B hex
Report slave ID	11 hex

Table 7.19

Function	Function Code	Sub-function code	Sub-function
Diagnostics	8	1	Restart communication
		2	Return diagnostic register
		10	Clear counters and diagnostic register
		11	Return bus message count
		12	Return bus communication error count
		13	Return bus exception error count
		14	Return slave message count

Table 7.20

### 7.8.11 Modbus Exception Codes

For a full explanation of the structure of an exception code response, refer to 7.8.5 *Function Field*.

Modbus Exception Codes		
Code	Name	Meaning
1	Illegal function	The function code received in the query is not an allowable action for the server (or slave). This may be because the function code is only applicable to newer devices, and was not implemented in the unit selected. It could also indicate that the server (or slave) is in the wrong state to process a request of this type, for example because it is not configured and is being asked to return register values.

Modbus Exception Codes		
Code	Name	Meaning
2	Illegal data address	The data address received in the query is not an allowable address for the server (or slave). More specifically, the combination of reference number and transfer length is invalid. For a controller with 100 registers, a request with offset 96 and length 4 would succeed, a request with offset 96 and length 5 generates exception 02.
3	Illegal data value	A value contained in the query data field is not an allowable value for server (or slave). This indicates a fault in the structure of the remainder of a complex request, such as that the implied length is incorrect. It specifically does NOT mean that a data item submitted for storage in a register has a value outside the expectation of the application program, since the Modbus protocol is unaware of the significance of any particular value of any particular register.
4	Slave device failure	An unrecoverable error occurred while the server (or slave) was attempting to perform the requested action.

Table 7.21

## 7.9 How to Access Parameters

### 7.9.1 Parameter Handling

The PNU (Parameter Number) is translated from the register address contained in the Modbus read or write message. The parameter number is translated to Modbus as (10 x parameter number) DECIMAL.

### 7.9.2 Storage of Data

The Coil 65 decimal determines whether data written to the frequency converter are stored in EEPROM and RAM (coil 65=1) or only in RAM (coil 65=0).

### 7.9.3 IND

The array index is set in Holding Register 9 and used when accessing array parameters.

### 7.9.4 Text Blocks

Parameters stored as text strings are accessed in the same way as the other parameters. The maximum text block size is 20 characters. If a read request for a parameter is for more characters than the parameter stores, the response is truncated. If the read request for a parameter is for fewer



characters than the parameter stores, the response is space filled.

### 7.9.5 Conversion Factor

The different attributes for each parameter can be seen in the section on factory settings. Since a parameter value can only be transferred as a whole number, a conversion factor must be used to transfer decimals.

### 7.9.6 Parameter Values

#### Standard data types

Standard data types are int16, int32, uint8, uint16 and uint32. They are stored as 4x registers (40001–4FFFF). The parameters are read using function 03HEX "Read Holding Registers." Parameters are written using the function 6HEX "Preset Single Register" for 1 register (16 bits), and the function 10HEX "Preset Multiple Registers" for 2 registers (32 bits). Readable sizes range from 1 register (16 bits) up to 10 registers (20 characters).

#### Non standard data types

Non standard data types are text strings and are stored as 4x registers (40001–4FFFF). The parameters are read using function 03HEX "Read Holding Registers" and written using function 10HEX "Preset Multiple Registers." Readable sizes range from 1 register (2 characters) up to 10 registers (20 characters).

### 7.10 Examples

The following examples illustrate various Modbus RTU commands.

#### 7.10.1 Read Coil Status (01 HEX)

##### Description

This function reads the ON/OFF status of discrete outputs (coils) in the frequency converter. Broadcast is never supported for reads.

##### Query

The query message specifies the starting coil and quantity of coils to be read. Coil addresses start at zero, that is, coil 33 is addressed as 32.

Example of a request to read coils 33-48 (Status Word) from slave device 01.

Field Name	Example (HEX)
Slave Address	01 (frequency converter address)
Function	01 (read coils)
Starting Address HI	00
Starting Address LO	20 (32 decimals) Coil 33
No. of Points HI	00
No. of Points LO	10 (16 decimals)
Error Check (CRC)	-

Table 7.22

#### Response

The coil status in the response message is packed as one coil per bit of the data field. Status is indicated as: 1=ON; 0=OFF. The LSB of the first data byte contains the coil addressed in the query. The other coils follow toward the high order end of this byte, and from 'low order to high order' in subsequent bytes.

If the returned coil quantity is not a multiple of eight, the remaining bits in the final data byte is padded with zeros (toward the high order end of the byte). The Byte Count field specifies the number of complete bytes of data.

Field Name	Example (HEX)
Slave Address	01 (frequency converter address)
Function	01 (read coils)
Byte Count	02 (2 bytes of data)
Data (Coils 40-33)	07
Data (Coils 48-41)	06 (STW=0607hex)
Error Check (CRC)	-

Table 7.23

### NOTE

**Coils and registers are addressed explicit with an off-set of -1 in Modbus.**

**I.e. Coil 33 is addressed as Coil 32.**

#### 7.10.2 Force/Write Single Coil (05 HEX)

##### Description

This function forces the coil to either ON or OFF. When broadcast the function forces the same coil references in all attached slaves.

##### Query

The query message specifies the coil 65 (parameter write control) to be forced. Coil addresses start at zero, that is, coil 65 is addressed as 64. Force Data=00 00HEX (OFF) or FF 00HEX (ON).

Field Name	Example (HEX)
Slave Address	01 (Frequency converter address)
Function	05 (write single coil)
Coil Address HI	00
Coil Address LO	40 (64 decimal) Coil 65
Force Data HI	FF
Force Data LO	00 (FF 00=ON)
Error Check (CRC)	-

Table 7.24

### Response

The normal response is an echo of the query, returned after the coil state has been forced.

Field Name	Example (HEX)
Slave Address	01
Function	05
Force Data HI	FF
Force Data LO	00
Quantity of Coils HI	00
Quantity of Coils LO	01
Error Check (CRC)	-

Table 7.25

### 7.10.3 Force/Write Multiple Coils (0F HEX)

This function forces each coil in a sequence of coils to either ON or OFF. When broadcast the function forces the same coil references in all attached slaves.

The query message specifies the coils 17 to 32 (speed set-point) to be forced.

Field Name	Example (HEX)
Slave Address	01 (frequency converter address)
Function	0F (write multiple coils)
Coil Address HI	00
Coil Address LO	10 (coil address 17)
Quantity of Coils HI	00
Quantity of Coils LO	10 (16 coils)
Byte Count	02
Force Data HI (Coils 8-1)	20
Force Data LO (Coils 16-9)	00 (ref.=2000 hex)
Error Check (CRC)	-

Table 7.26

### Response

The normal response returns the slave address, function code, starting address, and quantity of coils forced.

Field Name	Example (HEX)
Slave Address	01 (frequency converter address)
Function	0F (write multiple coils)
Coil Address HI	00
Coil Address LO	10 (coil address 17)
Quantity of Coils HI	00
Quantity of Coils LO	10 (16 coils)
Error Check (CRC)	-

Table 7.27

### 7.10.4 Read Holding Registers (03 HEX)

#### Description

This function reads the contents of holding registers in the slave.

#### Query

The query message specifies the starting register and quantity of registers to be read. Register addresses start at zero, that is, registers 1-4 are addressed as 0-3.

Example: Read 3-03 *Maximum Reference*, register 03030.

Field Name	Example (HEX)
Slave Address	01
Function	03 (read holding registers)
Starting Address HI	0B (Register address 3029)
Starting Address LO	05 (Register address 3029)
No. of Points HI	00
No. of Points LO	02 - (3-03 <i>Maximum Reference</i> is 32 bits long, i.e. 2 registers)
Error Check (CRC)	-

Table 7.28

#### Response

The register data in the response message are packed as two bytes per register, with the binary contents right justified within each byte. For each register, the first byte contains the high-order bits and the second contains the low-order bits.

Example: Hex 000088B8=35.000=15 Hz.

Field Name	Example (HEX)
Slave Address	01
Function	03
Byte Count	04
Data HI (Register 3030)	00
Data LO (Register 3030)	16
Data HI (Register 3031)	E3
Data LO (Register 3031)	60
Error Check (CRC)	-

**Table 7.29**

### 7.10.5 Preset Single Register (06 HEX)

#### Description

This function presets a value into a single holding register.

#### Query

The query message specifies the register reference to be preset. Register addresses start at zero, that is, register 1 is addressed as 0.

Example: Write to *1-00 Configuration Mode*, register 1000.

Field Name	Example (HEX)
Slave Address	01
Function	06
Register Address HI	03 (Register address 999)
Register Address LO	E7 (Register address 999)
Preset Data HI	00
Preset Data LO	01
Error Check (CRC)	-

**Table 7.30**

#### Response

The normal response is an echo of the query, returned after the register contents have been passed.

Field Name	Example (HEX)
Slave Address	01
Function	06
Register Address HI	03
Register Address LO	E7
Preset Data HI	00
Preset Data LO	01
Error Check (CRC)	-

**Table 7.31**

### 7.10.6 Preset Multiple Registers (10 HEX)

#### Description

This function presets values into a sequence of holding registers.

#### Query

The query message specifies the register references to be preset. Register addresses start at zero, that is, register 1 is addressed as 0. Example of a request to preset two registers (set *1-24 Motor Current* to 738 (7.38 A)):

Field Name	Example (HEX)
Slave Address	01
Function	10
Starting Address HI	04
Starting Address LO	19
No. of Registers HI	00
No. of registers LO	02
Byte Count	04
Write Data HI (Register 4: 1049)	00
Write Data LO (Register 4: 1049)	00
Write Data HI (Register 4: 1050)	02
Write Data LO (Register 4: 1050)	E2
Error Check (CRC)	-

**Table 7.32**

#### Response

The normal response returns the slave address, function code, starting address, and quantity of registers preset.

Field Name	Example (HEX)
Slave Address	01
Function	10
Starting Address HI	04
Starting Address LO	19
No. of Registers HI	00
No. of registers LO	02
Error Check (CRC)	-

**Table 7.33**

## 7.11 Danfoss FC Control Profile

### 7.11.1 Control Word According to FC Profile (8-10 Protocol = FC profile)

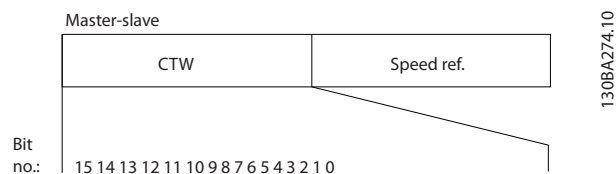

Illustration 7.13

Bit	Bit value=0	Bit value=1
00	Reference value	external selection lsb
01	Reference value	external selection msb
02	DC brake	Ramp
03	Coasting	No coasting
04	Quick stop	Ramp
05	Hold output frequency	use ramp
06	Ramp stop	Start
07	No function	Reset
08	No function	Jog
09	Ramp 1	Ramp 2
10	Data invalid	Data valid
11	Relay 01 open	Relay 01 active
12	Relay 02 open	Relay 02 active
13	Parameter set-up	selection lsb
15	No function	Reverse

Table 7.34

#### Explanation of the control bits

##### Bits 00/01

Bits 00 and 01 are used to choose between the four reference values, which are pre-programmed in *3-10 Preset Reference* according to the *Table 7.35*.

Programmed ref. value	Parameter	Bit 01	Bit 00
1	<i>3-10 Preset Reference</i> [0]	0	0
2	<i>3-10 Preset Reference</i> [1]	0	1
3	<i>3-10 Preset Reference</i> [2]	1	0
4	<i>3-10 Preset Reference</i> [3]	1	1

Table 7.35 Control Bits

## NOTE

Make a selection in *8-56 Preset Reference Select* to define how Bit 00/01 gates with the corresponding function on the digital inputs.

##### Bit 02, DC brake

Bit 02='0' leads to DC braking and stop. Set braking current and duration in *2-01 DC Brake Current* and *2-02 DC Braking Time*.

Bit 02='1' leads to ramping.

##### Bit 03, Coasting

Bit 03='0': The frequency converter immediately "lets go" of the motor, (the output transistors are "shut off") and it coasts to a standstill.

Bit 03='1': The frequency converter starts the motor if the other starting conditions are met.

Make a selection in *8-50 Coasting Select* to define how Bit 03 gates with the corresponding function on a digital input.

##### Bit 04, Quick stop

Bit 04='0': Makes the motor speed ramp down to stop (set in *3-81 Quick Stop Ramp Time*).

##### Bit 05, Hold output frequency

Bit 05='0': The present output frequency (in Hz) freezes. Change the frozen output frequency only with the digital inputs (*5-10 Terminal 18 Digital Input* to *5-13 Terminal 29 Digital Input*) programmed to *Speed up=21* and *Slow down=22*.

## NOTE

If Freeze output is active, the frequency converter can only be stopped by the following:

- Bit 03 Coasting stop
- Bit 02 DC braking
- Digital input (*5-10 Terminal 18 Digital Input* to *5-13 Terminal 29 Digital Input*) programmed to *DC braking=5*, *Coasting stop=2*, or *Reset and coasting stop=3*.

##### Bit 06, Ramp stop/start

Bit 06='0': Causes a stop and makes the motor speed ramp down to stop via the selected ramp down parameter. Bit 06='1': Permits the Frequency converter to start the motor, if the other starting conditions are met.

Make a selection in *8-53 Start Select* to define how Bit 06 Ramp stop/start gates with the corresponding function on a digital input.

##### Bit 07, Reset Bit 07='0': No reset.

Bit 07='1': Resets a trip. Reset is activated on the signal's leading edge, that is, when changing from logic '0' to logic '1'.

Bit 08, Jog

Bit 08='1': The output frequency is determined by 3-11 Jog Speed [Hz].

Bit 09, Selection of ramp 1/2

Bit 09="0": Ramp 1 is active (3-41 Ramp 1 Ramp Up Time to 3-42 Ramp 1 Ramp Down Time).

Bit 09="1": Ramp 2 (3-51 Ramp 2 Ramp Up Time to 3-52 Ramp 2 Ramp Down Time) is active.

Bit 10, Data not valid/Data valid

Tell the frequency converter whether to use or ignore the control word.

Bit 10='0': The control word is ignored. Bit 10='1': The control word is used. This function is relevant because the telegram always contains the control word, regardless of the telegram type. Turn off the control word if not wanting to use it when updating or reading parameters.

Bit 11, Relay 01

Bit 11="0": Relay not activated.

Bit 11="1": Relay 01 activated provided that Control word bit 11=36 is chosen in 5-40 Function Relay.

Bit 12, Relay 02

Bit 12="0": Relay 02 is not activated. Bit 12="1": Relay 02 is activated provided that Control word bit 12=37 is chosen in 5-40 Function Relay.

Bit 13, Selection of set-up

Use bit 13 to choose from the 2 menu set-ups according to the table.

Set-up	Bit 13
1	0
2	1

Table 7.36

The function is only possible when Multi Set-Ups=9 is selected in 0-10 Active Set-up.

Make a selection in 8-55 Set-up Select to define how Bit 13 gates with the corresponding function on the digital inputs.

Bit 15 Reverse

Bit 15='0': No reversing.

Bit 15='1': Reversing. In the default setting, reversing is set to digital in 8-54 Reversing Select. Bit 15 causes reversing only when Ser. communication, Logic or Logic and is selected.

7.11.2 Status Word According to FC Profile (STW) (8-30 Protocol = FC profile)

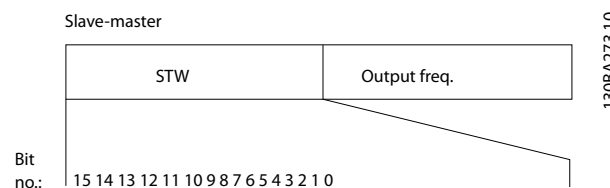

Illustration 7.14

Bit	Bit=0	Bit=1
00	Control not ready	Control ready
01	Drive not ready	Drive ready
02	Coasting	Enable
03	No error	Trip
04	No error	Error (no trip)
05	Reserved	-
06	No error	Triplock
07	No warning	Warning
08	Speed ≠ reference	Speed=reference
09	Local operation	Bus control
10	Out of frequency limit	Frequency limit OK
11	No operation	In operation
12	Drive OK	Stopped, auto start
13	Voltage OK	Voltage exceeded
14	Torque OK	Torque exceeded
15	Timer OK	Timer exceeded

Table 7.37

**Explanation of the status bits**

Bit 00, Control not ready/ready

Bit 00='0': The frequency converter trips.

Bit 00='1': The frequency converter controls are ready but the power component does not necessarily receive any power supply (in case of external 24 V supply to controls).

Bit 01, Drive ready

Bit 01='1': The frequency converter is ready for operation but the coasting command is active via the digital inputs or via serial communication.

Bit 02, Coasting stop

Bit 02='0': The frequency converter releases the motor.

Bit 02='1': The frequency converter starts the motor with a start command.

Bit 03, No error/trip

Bit 03='0': The frequency converter is not in fault mode.

Bit 03='1': The frequency converter trips. To re-establish operation, press [Reset].

Bit 04, No error/error (no trip)

Bit 04='0': The frequency converter is not in fault mode. Bit 04='1': The frequency converter shows an error but does not trip.

Bit 05, Not used

Bit 05 is not used in the status word.

Bit 06, No error / triplock

Bit 06='0': The frequency converter is not in fault mode. Bit 06='1': The frequency converter is tripped and locked.

Bit 07, No warning/warning

Bit 07='0': There are no warnings. Bit 07='1': A warning has occurred.

Bit 08, Speed≠ reference/speed=reference

Bit 08='0': The motor is running but the present speed is different from the preset speed reference. It might for example, be the case when the speed ramps up/down during start/stop. Bit 08='1': The motor speed matches the preset speed reference.

Bit 09, Local operation/bus control

Bit 09='0': [Off/Reset] is activate on the control unit or *Local control* in *F-02 Operation Method* is selected. It is not possible to control the frequency converter via serial communication. Bit 09='1' It is possible to control the frequency converter via the fieldbus/serial communication.

Bit 10, Out of frequency limit

Bit 10='0': The output frequency has reached the value in *4-12 Motor Speed Low Limit [Hz]* or *4-14 Motor Speed High Limit [Hz]*. Bit 10='1': The output frequency is within the defined limits.

Bit 11, No operation/in operation

Bit 11='0': The motor is not running. Bit 11='1': The coasting has a start signal or the output frequency is greater than 0 Hz.

Bit 12, Drive OK/stopped, autostart:

Bit 12='0': There is no temporary over temperature on the inverter. Bit 12='1': The inverter stops because of over temperature but the unit does not trip and resumes operation once the over temperature stops.

Bit 13, Voltage OK/limit exceeded

Bit 13='0': There are no voltage warnings. Bit 13='1': The DC voltage in the frequency converter's intermediate circuit is too low or too high.

Bit 14, Torque OK/limit exceeded

Bit 14='0': The motor current is lower than the torque limit selected in *4-18 Current Limit*. Bit 14='1': The torque limit in *4-18 Current Limit* is exceeded.

Bit 15, Timer OK/limit exceeded

Bit 15='0': The timers for motor thermal protection and thermal protection are not exceeded 100%. Bit 15='1': One of the timers exceeds 100%.

### 7.11.3 Bus Speed Reference Value

Speed reference value is transmitted to the frequency converter in a relative value in %. The value is transmitted in the form of a 16-bit word; in integers (0-32767) the value 16384 (4000 Hex) corresponds to 100%. Negative figures are formatted by means of 2's complement. The Actual Output frequency (MAV) is scaled in the same way as the bus reference.

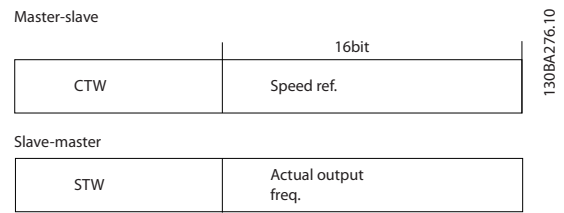

Illustration 7.15

The reference and MAV are scaled as follows:

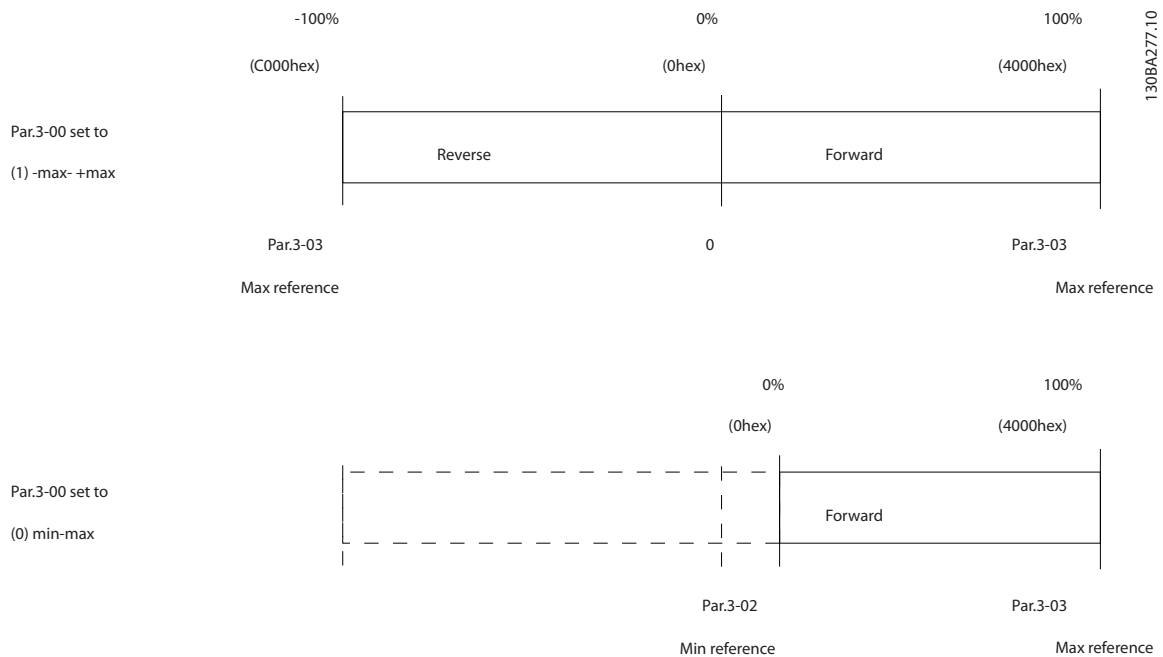
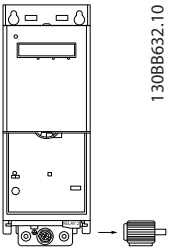
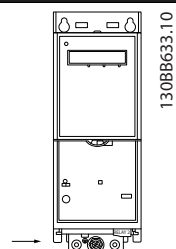

Illustration 7.16

## 8 General Specifications and Troubleshooting

### 8.1 Mains Supply Tables

#### 8.1.1 Mains Supply 3x200-240 V AC

Frequency converter	PK2 5	PK3 7	PK7 5	P1K 5	P2K2	P3K7	P5K5	P7K5	P11K	P15K	P18K	P22K	P30K	P37K	P45K	
Typical shaft output [kW]	0.25	0.37	0.75	1.5	2.2	3.7	5.5	7.5	11.0	15.0	18.5	22.0	30.0	37.0	45.0	
Typical shaft output [hp]	0.33	0.5	1.0	2.0	3.0	5.0	7.5	10.0	15.0	20.0	25.0	30.0	40.0	50.0	60.0	
IP20 frame	H1	H1	H1	H1	H2	H3	H4	H4	H5	H6	H6	H7	H7	H8	H8	
Max. cable size in terminals (mains, motor) [mm <sup>2</sup> /AWG]	4/10	4/10	4/10	4/10	4/10	4/10	16/6	16/6	16/6	35/2	35/2	50/1	50/1	95/0	120/(4/0)	
<b>Output current</b>																
 130BB632.10	<b>40 °C ambient temperature</b>															
	Continuous (3x200-240 V) [A]	1.5	2.2	4.2	6.8	9.6	15.2	22.0	28.0	42.0	59.4	74.8	88.0	115.0	143.0	170.0
	Intermittent (3x200-240 V) [A]	1.7	2.4	4.6	7.5	10.6	16.7	24.2	30.8	46.2	65.3	82.3	96.8	126.5	157.3	187.0
<b>Max. input current</b>																
 130BB633.10	Continuous (3x200-240 V) [A]	1.1	1.6	2.8	5.6	8.6/7.2	14.1/12.0	21.0/18.0	28.3/24.0	41.0/38.2	52.7	65.0	76.0	103.7	127.9	153.0
	Intermittent (3x200-240 V) [A]	1.2	1.8	3.1	6.2	9.5/7.9	15.5/13.2	23.1/19.8	31.1/26.4	45.1/42.0	58.0	71.5	83.7	114.1	140.7	168.3
Max. mains fuses		See 5.2.4 Fuses														
Estimated power loss [W], Best case/typical <sup>1)</sup>		12/14	15/18	21/26	48/60	80/102	97/120	182/204	229/268	369/386	512	697	879	1149	1390	1500
Weight enclosure IP20 [kg]		2.	2.0	2.0	2.1	3.4	4.5	7.9	7.9	9.5	24.5	24.5	36.0	36.0	51.0	51.0
Efficiency [%], Best case/Typical <sup>1)</sup>		97.0/96.5	97.3/96.8	98.0/97.6	97.6/97.0	97.1/96.3	97.9/97.4	97.3/97.0	98.5/97.1	97.2/97.1	97.0	97.1	96.8	97.1	97.1	97.3
<b>Output current</b>																
<b>50 °C ambient temperature</b>																
Continuous (3x200-240 V) [A]		1.5	1.9	3.5	6.8	9.6	13.0	19.8	23.0	33.0	53.5	66.6	79.2	103.5	128.7	153.0
Intermittent (3x200-240 V) [A]		1.7	2.1	3.9	7.5	10.6	14.3	21.8	25.3	36.3	58.9	73.3	87.1	113.9	141.6	168.3

**Table 8.1**

1) At rated load conditions



8.1.2 Mains Supply 3x380-480 V AC

Frequency converter	PK37	PK75	P1K5	P2K2	P3K0	P4K0	P5K5	P7K5	P11K	P15K	P18K	P22K	P30K	P37K	P45K	P55K	P75K	P90K	
Typical shaft output [kW]	0.37	0.75	1.5	2.2	3.0	4.0	5.5	7.5	11.0	15.0	18.5	22.0	30.0	37.0	45.0	55.0	75.0	90.0	
Typical shaft output [hp]	0.5	1.0	2.0	3.0	4.0	5.0	7.5	10.0	15.0	20.0	25.0	30.0	40.0	50.0	60.0	70.0	100.0	125.0	
IP20 frame	H1	H1	H1	H2	H2	H2	H3	H3	H4	H4	H5	H5	H6	H6	H6	H7	H7	H8	
Max. cable size in terminals (mains, motor) [mm <sup>2</sup> /AWG]	4/10	4/10	4/10	4/10	4/10	4/10	4/10	4/10	16/6	16/6	16/6	16/6	35/2	35/2	35/2	50/1	95/0	120/250MCM	
<b>Output current</b>																			
<b>40 °C ambient temperature</b>																			
	Continuous (3x380-440 V) [A]	1.2	2.2	3.7	5.3	7.2	9.0	12.0	15.5	23.0	31.0	37.0	42.5	61.0	73.0	90.0	106.0	147.0	177.0
	Intermittent (3x380-440 V) [A]	1.3	2.4	4.1	5.8	7.9	9.9	13.2	17.1	25.3	34.0	40.7	46.8	67.1	80.3	99.0	116.0	161.0	194.0
	Continuous (3x440-480 V) [A]	1.1	2.1	3.4	4.8	6.3	8.2	11.0	14.0	21.0	27.0	34.0	40.0	52.0	65.0	80.0	105.0	130.0	160.0
	Intermittent (3x440-480 V) [A]	1.2	2.3	3.7	5.3	6.9	9.0	12.1	15.4	23.1	29.7	37.4	44.0	57.2	71.5	88.0	115.0	143.0	176.0
<b>Max. input current</b>																			
	Continuous (3x380-440 V) [A]	1.2	2.1	3.5	4.7	6.3	8.3	11.2	15.1	22.1	29.9	35.2	41.5	57.0	70.0	84.0	103.0	140.0	166.0
	Intermittent (3x380-440 V) [A]	1.3	2.3	3.9	5.2	6.9	9.1	12.3	16.6	24.3	32.9	38.7	45.7	62.7	77.0	92.4	113.0	154.0	182.0
	Continuous (3x440-480 V) [A]	1.0	1.8	2.9	3.9	5.3	6.8	9.4	12.6	18.4	24.7	29.3	34.6	49.2	60.6	72.5	88.6	120.9	142.7
	Intermittent (3x440-480 V) [A]	1.1	2.0	3.2	4.3	5.8	7.5	10.3	13.9	20.2	27.2	32.2	38.1	54.1	66.7	79.8	97.5	132.9	157.0
See 5.2.4 Fuses																			

Table 8.2

Frequency converter	PK37	PK75	P1K5	P2K2	P3K0	P4K0	P5K5	P7K5	P11K	P15K	P18K	P22K	P30K	P37K	P45K	P55K	P75K	P90K
Estimated power loss [W], Best case/typical <sup>1)</sup>	13/15	16/21	46/57	46/58	66/83	95/118	104/131	159/198	248/274	353/379	412/456	475/523	733	922	1067	1133	1733	2141
Weight enclosure IP20 [kg]	2.0	2.0	2.1	3.3	3.3	3.4	4.3	4.5	7.9	7.9	9.5	9.5	24.5	24.5	24.5	36.0	36.0	51.0
Efficiency [%], Best case/Typical 1	97.8/97.9	98.0/97.6	97.7/97.2	98.3/97.9	98.2/97.8	98.0/97.6	98.4/98.0	98.2/97.8	98.1/97.9	98.0/97.8	98.1/97.9	98.1/97.9	97.8	97.7	98	98.2	97.8	97.9
<b>Output current</b>																		
<b>50 °C ambient temperature</b>																		
Continuous (3x380-440 V) [A]	1.04	1.93	3.7	4.85	6.3	8.4	10.9	14.0	20.9	28.0	34.1	38.0	48.8	58.4	72.0	74.2	102.9	123.9
Intermittent (3x380-440 V) [A]	1.1	2.1	4.07	5.4	6.9	9.2	12.0	15.4	23.0	30.8	37.5	41.8	53.7	64.2	79.2	81.6	113.2	136.3
Continuous (3x440-480 V) [A]	1.0	1.8	3.4	4.4	5.5	7.5	10.0	12.6	19.1	24.0	31.3	35.0	41.6	52.0	64.0	73.5	91.0	112.0
Intermittent (3x440-480 V) [A]	1.1	2.0	3.7	4.8	6.1	8.3	11.0	13.9	21.0	26.4	34.4	38.5	45.8	57.2	70.4	80.9	100.1	123.2

Table 8.3

8.1.3 Mains Supply 3x380-480 V AC

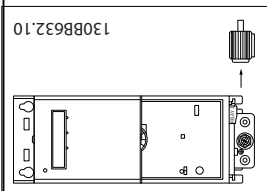
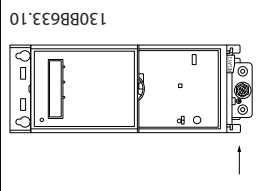
Frequency converter	PK75	P1K5	P2K2	P3K0	P4K0	P5K5	P7K5	P11K	P15K	P18K	P18K	P11K	P15K	P18K	P22K	P30K	P37K	P45K	P55K	P75K	P90K
Typical shaft output [kW]	0.75	1.5	2.2	3.0	4.0	5.5	7.5	11	15	18.5	18.5	11	15	18.5	22.0	30.0	37.0	45.0	55.0	75.0	90.0
Typical shaft output [hp]	1.0	2.0	3.0	4.0	5.0	7.5	10.0	15	20	25	25	15.0	20	25.0	30.0	40.0	50.0	60.0	70.0	100.0	125.0
IP54 frame	I2	I2	I2	I2	I2	I3	I3	I4	I4	I4	I4	I4	I4	I4	I6	I6	I6	I7	I7	I8	I8
Max. cable size in terminals (mains, motor) [mm <sup>2</sup> /AWG]	4/10	4/10	4/10	4/10	4/10	4/10	4/10	16/6	16/6	16/6	16/6	16/6	16/6	16/6	35/2	35/2	35/2	50/1	50/1	95/ (3/0)	120/ (4/0)
<b>Output current</b>	<b>40 °C ambient temperature</b>																				
Continuous (3x380-440 V) [A]	2.2	3.7	5.3	7.2	9.0	12.0	15.5	23.0	31.0	37.0	37.0	24	32	37.5	44.0	61.0	73.0	90.0	106.0	147.0	177.0
	2.4	4.1	5.8	7.9	9.9	13.2	17.1	25.3	34.0	40.7	40.7	26.2	35.2	41.3	48.4	67.1	80.3	99.0	116.6	161.7	194.7
	2.1	3.4	4.8	6.3	8.2	11.0	14.0	21.0	27.0	34.0	34.0	21	27	34	40.0	52.0	65.0	80.0	105.0	130.0	160.0
	2.3	3.7	5.3	6.9	9.0	12.1	15.4	23.1	29.7	37.4	37.4	23.1	29.7	37.4	44.0	57.2	71.5	88.0	115.5	143.0	176.0
Max. input current	2.1	3.5	4.7	6.3	8.3	11.2	15.1	22.1	29.9	35.2	35.2	22	29	34	41.8	57.0	70.3	84.2	102.9	140.3	165.6
	2.3	3.9	5.2	6.9	9.1	12.3	16.6	24.3	32.9	38.7	38.7	24.2	31.9	37.3	46.0	62.7	77.4	92.6	113.1	154.3	182.2
	1.8	2.9	3.9	5.3	6.8	9.4	12.6	18.4	24.7	29.3	29.3	19	25	31	36.0	49.2	60.6	72.5	88.6	120.9	142.7
	2.0	3.2	4.3	5.8	7.5	10.3	13.9	20.2	27.2	32.2	32.2	20.9	27.5	34.1	39.6	54.1	66.7	79.8	97.5	132.9	157.0
Max. mains fuses	See 5.2.4 Fuses																				

Table 8.4

Frequency converter	PK75	P1K5	PK2K2	PK3K	PK4K	PK5K	PK7K	P11K	P15K	P18K	PK11	PK15	P18K	P22K	P30K	P37K	P45K	P55K	P75K	P90K
Estimated power loss [W], Best case/typical <sup>1)</sup>	21/ 16	46/ 57	46/ 58	66/ 83	95/ 118	104/ 131	159/ 198	248/ 274	353/ 379	412/ 456	242	330	396	496	734	995	840	1099	1520	1781
Weight enclosure IP54 [kg]	5.3	5.3	5.3	5.3	5.3	7.2	7.2	13.8	13.8	13.8	23	23	23	27	27	27	45	45	65	65
Efficiency [%], Best case/Typical 1	98.0/ 97.6	97.7/ 97.2	98.3/ 97.9	98.2/ 97.8	98.0/ 97.6	98.4/ 98.0	98.2/ 97.8	98.1/ 97.9	98.0/ 97.8	98.1/ 97.8	98.0	98.0	98.0	98.0	97.8	97.6	98.3	98.2	98.1	98.3
<b>Output current</b>																				
<b>50 °C ambient temperature</b>																				
Continuous (3x380-440 V) [A]	1.93	3.7	4.85	6.3	7.5	10.9	14.0	20.9	28.0	33.0	19.2	25.6	30	35.2	48.8	58.4	63.0	74.2	102.9	123.9
Intermittent (3x380-440 V) [A]	2.1	4.07	5.4	6.9	9.2	12.0	15.4	23.0	30.8	36.3	21.2	28.2	33	38.7	53.9	64.2	69.3	81.6	113.2	136.3
Continuous (3x440-480 V) [A]	1.8	3.4	4.4	5.5	6.8	10.0	12.6	19.1	24.0	30.0	16.8	21.6	27.2	32.0	41.6	52.0	56.0	73.5	91.0	112.0
Intermittent (3x440-480 V) [A]	2.0	3.7	4.8	6.1	8.3	11.0	13.9	21.0	26.4	33.0	18.5	23.8	30	35.2	45.8	57.2	61.6	80.9	100.1	123.2

Table 8.5

## 8.1.4 Mains Supply 3x525-600 V AC

Frequency converter	P2K2	P3K0	P3K7	P5K5	P7K5	P11K	P15K	P18K	P22K	P30K	P37K	P45K	P55K	P75K	P90K	
Typical shaft output [kW]	2.2	3.0	3.7	5.5	7.5	11.0	15.0	18.5	22.0	30.0	37	45.0	55.0	75.0	90.0	
Typical shaft output [hp]	3.0	4.0	5.0	7.5	10.0	15.0	20.0	25.0	30.0	40.0	50.0	60.0	70.0	100.0	125.0	
IP20 frame	H9	H9	H9	H9	H9	H10	H10	H6	H6	H6	H7	H7	H7	H8	H8	
Max. cable size in terminals (mains, motor) [mm <sup>2</sup> /AWG]	4/10	4/10	4/10	4/10	4/10	10/8	10/8	35/2	35/2	35/2	50/1	50/1	50/1	95/0	120/(4/0)	
<b>Output current</b>																
 130BB632.10	<b>40 °C ambient temperature</b>															
	Continuous (3x525-550 V) [A]	4.1	5.2	6.4	9.5	11.5	19.0	23.0	28.0	36.0	43.0	54.0	65.0	87.0	105.0	137.0
	Intermittent (3x525-550 V) [A]	4.5	5.7	7.0	10.5	12.7	20.9	25.3	30.8	39.6	47.3	59.4	71.5	95.7	115.5	150.7
	Continuous (3x551-600 V) [A]	3.9	4.9	6.1	9.0	11.0	18.0	22.0	27.0	34.0	41.0	52.0	62.0	83.0	100.0	131.0
	Intermittent (3x551-600 V) [A]	4.3	5.4	6.7	9.9	12.1	19.8	24.2	29.7	37.4	45.1	57.2	68.2	91.3	110.0	144.1
<b>Max. input current</b>																
 130BB633.10	Continuous (3x525-550 V) [A]	3.7	5.1	5.0	8.7	11.9	16.5	22.5	27.0	33.1	45.1	54.7	66.5	81.3	109.0	130.9
	Intermittent (3x525-550 V) [A]	4.1	5.6	6.5	9.6	13.1	18.2	24.8	29.7	36.4	49.6	60.1	73.1	89.4	119.9	143.9
	Continuous (3x551-600 V) [A]	3.5	4.8	5.6	8.3	11.4	15.7	21.4	25.7	31.5	42.9	52.0	63.3	77.4	103.8	124.5
	Intermittent (3x551-600 V) [A]	3.9	5.3	6.2	9.2	12.5	17.3	23.6	28.3	34.6	47.2	57.2	69.6	85.1	114.2	137.0
Max. mains fuses	See 5.2.4 Fuses															
Estimated power loss [W], Best case/typical <sup>1)</sup>	65	90	110	132	180	216	294	385	458	542	597	727	1092	1380	1658	
Weight enclosure IP54 [kg]	6.6	6.6	6.6	6.6	6.6	11.5	11.5	24.5	24.5	24.5	36.0	36.0	36.0	51.0	51.0	
Efficiency [%], Best case/Typical 1	97.9	97	97.9	98.1	98.1	98.4	98.4	98.4	98.4	98.5	98.5	98.7	98.5	98.5	98.5	
<b>Output current</b>																
	<b>50 °C ambient temperature</b>															
	Continuous (3x525-550 V) [A]	2.9	3.6	4.5	6.7	8.1	13.3	16.1	19.6	25.2	30.1	37.8	45.5	60.9	73.5	95.9
	Intermittent (3x525-550 V) [A]	3.2	4.0	4.9	7.4	8.9	14.6	17.7	21.6	27.7	33.1	41.6	50.0	67.0	80.9	105.5
	Continuous (3x551-600 V) [A]	2.7	3.4	4.3	6.3	7.7	12.6	15.4	18.9	23.8	28.7	36.4	43.3	58.1	70.0	91.7
Intermittent (3x551-600 V) [A]	3.0	3.7	4.7	6.9	8.5	13.9	16.9	20.8	26.2	31.6	40.0	47.7	63.9	77.0	100.9	

Table 8.6

## 8.2 General Specifications

### Protection and features

- Electronic thermal motor protection motor protection against overload.
- Temperature monitoring of the heatsink ensures that the frequency converter trips in case of overtemperature.
- The frequency converter is protected against short-circuits between motor terminals U, V, W.
- If a motor phase is missing, the frequency converter trips and issues an alarm.
- If a mains phase is missing, the frequency converter trips or issues a warning (depending on the load).
- Monitoring of the intermediate circuit voltage ensures that the frequency converter trips if the intermediate circuit voltage is too low or too high.
- The frequency converter is protected against earth faults on motor terminals U, V, W.

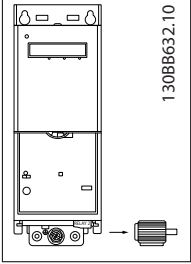
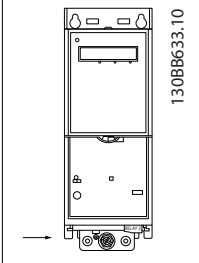
### Mains supply (L1, L2, L3)

Supply voltage	200-240 V $\pm$ 10%
Supply voltage	380-480 V $\pm$ 10%
Supply voltage	525-600 V $\pm$ 10%
Supply frequency	50/60 Hz
Max. imbalance temporary between mains phases	3.0% of rated supply voltage
True Power Factor ( $\lambda$ )	$\geq$ 0.9 nominal at rated load
Displacement Power Factor ( $\cos\phi$ ) near unity	(>0.98)
Switching on the input supply L1, L2, L3 (power-ups) enclosure frame H1-H5, I2, I3, I4	Max. 2 times/min.
Switching on the input supply L1, L2, L3 (power-ups) enclosure frame H6-H8, I6-I8	Max. 1 time/min.
Environment according to EN 60664-1	overvoltage category III/pollution degree 2
The unit is suitable for use on a circuit capable of delivering not more than 100.000 RMS symmetrical Amperes, 240/480 V maximum.	

### Motor output (U, V, W)

Output voltage	0-100% of supply voltage
Output frequency	0-200 Hz (VVC <sup>plus</sup> ), 0-400 Hz (u/f)
Switching on output	Unlimited
Ramp times	0.05-3600 s

### Cable lengths and cross sections

Max. motor cable length, screened/armoured (EMC correct installation)	See 2.8.3 EMC Test Results
Max. motor cable length, unscreened/unarmoured	50 m
Max. cross section to motor, mains*	
Cross section DC terminals for filter feedback on enclosure frame H1-H3, I2, I3, I4	4 mm <sup>2</sup> /11 AWG
Cross section DC terminals for filter feedback on enclosure frame H4-H5	16 mm <sup>2</sup> /6 AWG
Maximum cross section to control terminals, rigid wire	2.5 mm <sup>2</sup> /14 AWG
Maximum cross section to control terminals, flexible cable	2.5 mm <sup>2</sup> /14 AWG
Minimum cross section to control terminals	0.05 mm <sup>2</sup> /30 AWG

\*See 8.1.2 Mains Supply 3x380-480 V AC for more information

### Digital inputs

Programmable digital inputs	4
Terminal number	18, 19, 27, 29
Logic	PNP or NPN
Voltage level	0-24 V DC
Voltage level, logic '0' PNP	<5 V DC
Voltage level, logic '1' PNP	>10 V DC
Voltage level, logic '0' NPN	>19 V DC
Voltage level, logic '1' NPN	<14 V DC
Maximum voltage on input	28 V DC

Input resistance, $R_i$	Approx. 4 k
Digital input 29 as thermistor input	Fault: >2.9 k $\Omega$ and no fault: <800 $\Omega$

**Analog inputs**

Number of analog inputs	2
Terminal number	53, 54
Terminal 53 mode	Parameter 6-19: 1=voltage, 0=current
Terminal 54 mode	Parameter 6-29: 1=voltage, 0=current
Voltage level	0-10 V
Input resistance, $R_i$	approx. 10 k $\Omega$
Max. voltage	20 V
Current level	0/4 to 20 mA (scalable)
Input resistance, $R_i$	<500 $\Omega$
Max. current	29 mA

**Analog output**

Number of programmable analog outputs	2
Terminal number	42, 45 <sup>1)</sup>
Current range at analog output	0/4-20 mA
Max. load to common at analog output	500 $\Omega$
Max. voltage at analog output	17 V
Accuracy on analog output	Max. error: 0.4% of full scale
Resolution on analog output	10 bit

1) Terminal 42 and 45 can also be programmed as digital outputs.

**Digital output**

Number of digital outputs	2
Terminal number	42, 45 <sup>1)</sup>
Voltage level at digital output	17 V
Max. output current at digital output	20 mA
Max. load at digital output	1 k $\Omega$

1) Terminals 42 and 45 can also be programmed as analog output.

**Control card, RS-485 serial communication**

Terminal number	68 (P, TX+, RX+), 69 (N, TX-, RX-)
Terminal number	61 Common for terminals 68 and 69

**Control card, 24 V DC output**

Terminal number	12
Max. load enclosure frame H1-H8, I2-I8	80 mA

**Relay output**

Programmable relay output	2
Relay 01 and 02	01-03 (NC), 01-02 (NO), 04-06 (NC), 04-05 (NO)
Max. terminal load (AC-1) <sup>1)</sup> on 01-02/04-05 (NO) (Resistive load)	250 V AC, 3 A
Max. terminal load (AC-15) <sup>1)</sup> on 01-02/04-05 (NO) (Inductive load @ $\cos\phi$ 0.4)	250 V AC, 0.2 A
Max. terminal load (DC-1) <sup>1)</sup> on 01-02/04-05 (NO) (Resistive load)	30 V DC, 2 A
Max. terminal load (DC-13) <sup>1)</sup> on 01-02/04-05 (NO) (Inductive load)	24 V DC, 0.1 A
Max. terminal load (AC-1) <sup>1)</sup> on 01-03/04-06 (NC) (Resistive load)	250 V AC, 3 A
Max. terminal load (AC-15) <sup>1)</sup> on 01-03/04-06 (NC) (Inductive load @ $\cos\phi$ 0.4)	250 V AC, 0.2 A
Max. terminal load (DC-1) <sup>1)</sup> on 01-03/04-06 (NC) (Resistive load)	30 V DC, 2 A
(NC) (Resistive load)	Min. terminal load on 01-03 (NC), 01-02 (NO) 24 V DC 10 mA, 24 V AC 20 mA
Environment according to EN 60664-1	Overvoltage category III/pollution degree 2

1) IEC 60947 parts 4 and 5.

Control card, 10 V DC output

Terminal number	50
Output voltage	10.5 V ±0.5 V
Max. load	25 mA

All inputs, outputs, circuits, DC supplies and relay contacts are galvanically isolated from the supply voltage (PELV) and other high-voltage terminals.

Surroundings

Enclosure	IP20
Enclosure kit available	IP21, TYPE 1
Vibration test	1.0 g
Max. relative humidity	5%-95% (IEC 60721-3-3; Class 3K3 (non-condensing) during operation
Aggressive environment (IEC 60721-3-3), coated (standard) frame H1-H5	Class 3C3
Aggressive environment (IEC 60721-3-3), non-coated frame H6-H10	Class 3C2
Aggressive environment (IEC 60721-3-3), coated (optional) frame H6-H10	Class 3C3
Test method according to IEC 60068-2-43 H2S (10 days)	
Ambient temperature	See max. output current at 40/50 °C in the tables mains supply

Derating for high ambient temperature, see 8.2.1 Surroundings

Minimum ambient temperature during full-scale operation	0 °C
Minimum ambient temperature at reduced performance, enclosure frame H1-H5	-20 °C
Minimum ambient temperature at reduced performance, enclosure frame H6-H10	-10 °C
Temperature during storage/transport	-30 to +65/70 °C
Maximum altitude above sea level without derating	1000 m
Maximum altitude above sea level with derating	3000 m
Derating for high altitude, see 8.2.1 Surroundings	
Safety standards	EN/IEC 61800-5-1, UL 508C
EMC standards, Emission	EN 61800-3, EN 61000-6-3/4, EN 55011, IEC 61800-3 EN 61800-3, EN 61000-3-12, EN 61000-6-1/2, EN 61000-4-2, EN 61000-4-3, EN 61000-4-4, EN 61000-4-5, EN 61000-4-6
EMC standards, Immunity	



### 8.3 Acoustic Noise

The acoustic noise from the frequency converter comes from 3 sources:

1. DC intermediate circuit coils
2. Integral fan
3. RFI filter choke

Frame	Level [dBA]
I4	60.8
I5	67
I6	70
I7	62
I8	65.6

Table 8.7 Typical Values Measured at a Distance of 1 m from the Unit

Frame	Level [dBA]
H1	57.3
H2	59.5
H3	53.8
H4	64
H5	63.7
H6	71.5
H7	67.5 (75 kW 71.5 dB)
H8	73.5
H9	60
H10	62.9
I2	50.2
I3	54



## 8.4 dU/Dt

	Cable length [m]	AC line voltage [V]	Rise time [usec]	V <sub>peak</sub> [kV]	dU/dt [kv/usec]
200 V 0.25 kW	5	240	0,121	0,498	3.256
	25	240	0,182	0,615	2,706
	50	240	0,258	0,540	1.666
200 V 0.37 kW	5	240	0,121	0,498	3.256
	25	240	0,182	0,615	2,706
	50	240	0,258	0,540	1.666
200 V 0.75 kW	5	240	0,121	0,498	3.256
	25	240	0,182	0,615	2,706
	50	240	0,258	0,540	1.666
200 V 1.5 kW	5	240	0,121	0,498	3.256
	25	240	0,182	0,615	2,706
	50	240	0,258	0,540	1.666
200 V 2.2 kW	5	240	0,18	0,476	2.115
	25	240	0,230	0,615	2.141
	50	240	0,292	0,566	1.550
200 V 3.7 kW	5	240	0,168	0,570	2.714
	25	240	0,205	0,615	2.402
	50	240	0,252	0,620	1.968
200 V 5.5 kW	5	240	0,128	0,445	2781,25
	25	240	0,224	0,594	2121,43
	50	240	0,328	0,596	1453,66
200 V 7.5 kW	5	240	0,18	0,502	2244
	25	240	0,22	0,598	2174,55
	50	240	0,292	0,615	1678
200 V 11 kW	36	240	0,176	0,56	2545,45
	50	240	0,216	0,599	2203,7
400 V 0.37 kW	5	400	0,160	0,808	4.050
	25	400	0,240	1.026	3.420
	50	400	0,340	1.056	2.517
400 V 0.75 kW	5	400	0,160	0,808	4.050
	25	400	0,240	1.026	3.420
	50	400	0,340	1.056	2.517
400 V 1.5 kW	5	400	0,160	0,808	4.050
	25	400	0,240	1.026	3.420
	50	400	0,340	1.056	2.517
400 V 2.2 kW	5	400	0,190	0,760	3.200
	25	400	0,293	1.026	2.801
	50	400	0,422	1.040	1.971
400 V 3.0 kW	5	400	0,190	0,760	3.200
	25	400	0,293	1.026	2.801
	50	400	0,422	1.040	1.971
400 V 4.0 kW	5	400	0,190	0,760	3.200
	25	400	0,293	1.026	2.801
	50	400	0,422	1.040	1.971
400 V 5.5 kW	5	400	0,168	0,81	3.857
	25	400	0,239	1.026	3.434
	50	400	0,328	1,05	2.560
400 V 7.5 kW	5	400	0,168	0,81	3.857
	25	400	0,239	1.026	3.434
	50	400	0,328	1,05	2.560

	Cable length [m]	AC line voltage [V]	Rise time [usec]	V <sub>peak</sub> [kV]	dU/dt [kv/usec]
400 V 11 kW	5	400	0,116	0,69	4870,69
	25	400	0,204	0,985	3799,02
	50	400	0,316	1,01	2563,29
400 V 15 kW	5	400	0,139	0,864	4,955
	50	400	0,338	1,008	2,365
400 V 18.5 kW	5	400	0,132	0,88	5.220
	25	400	0,172	1.026	4.772
	50	400	0,222	1,00	3.603
400 V 22 kW	5	400	0,132	0,88	5.220
	25	400	0,172	1.026	4.772
	50	400	0,222	1,00	3.603
400 V 30 kW	10	400	0,376	0,92	1,957
	50	400	0,536	0,97	1,448
	100	400	0,696	0,95	1,092
	150	400	0,8	0,965	0,965
	10	480	0,384	1,2	2,5
	50	480	0,632	1,18	1,494
	100	480	0,712	1,2	1,348
	150	480	0,832	1,17	1,125
	10	500	0,408	1,24	2,431
	50	500	0,592	1,29	1,743
	100	500	0,656	1,28	1,561
	150	500	0,84	1,26	1,2
400 V 37 kW	10	400	0,276	0,928	2,69
	50	400	0,432	1,02	1,889
	10	480	0,272	1,17	3,441
	50	480	0,384	1,21	2,521
	10	500	0,288	1,2	3,333
	50	500	0,384	1,27	2,646
400 V 45 kW	10	400	0,3	0,936	2,496
	50	400	0,44	0,924	1,68
	100	400	0,56	0,92	1,314
	150	400	0,8	0,92	0,92
	10	480	0,3	1,19	3,173
	50	480	0,4	1,15	2,3
	100	480	0,48	1,14	1,9
	150	480	0,72	1,14	1,267
	10	500	0,3	1,22	3,253
	50	500	0,38	1,2	2,526
	100	500	0,56	1,16	1,657
	150	500	0,74	1,16	1,254
400 V 55 kW	10	400	0,46	1,12	1,948
		480	0,468	1,3	2,222
400 V 75 kW	10	400	0,502	1,048	1,673
		480	0,52	1,212	1,869
		500	0,51	1,272	1,992
400 V 90 kW	10	400	0,402	1,108	2,155
		400	0,408	1,288	2,529
		400	0,424	1,368	2,585

	Cable length [m]	AC line voltage [V]	Rise time [usec]	V <sub>peak</sub> [kV]	dU/dt [kv/usec]
600 V 7.5 kW	5	525	0,192	0,972	4,083
	50	525	0,356	1,32	2,949
	5	600	0,184	1,06	4,609
	50	600	0,42	1,49	2,976

Table 8.8

### 8.5 Derating according to Ambient Temperature and Switching Frequency

The ambient temperature measured over 24 hours should be at least 5 °C lower than the max. ambient temperature. If the frequency converter is operated at high ambient temperature, the continuous output current should be decreased.

8

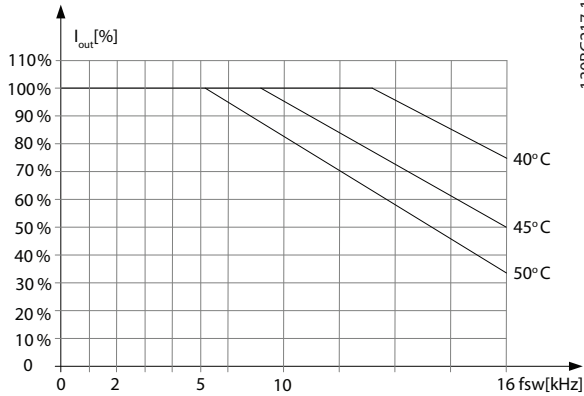

Illustration 8.1 200 V IP20 H1 0.25-0.75 kW

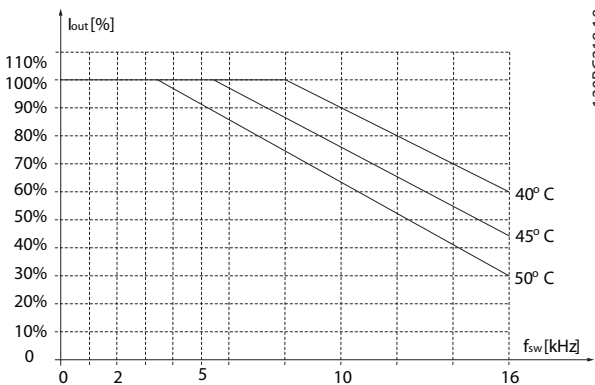

Illustration 8.2 400 V IP20 H1 0.37-1.5 kW

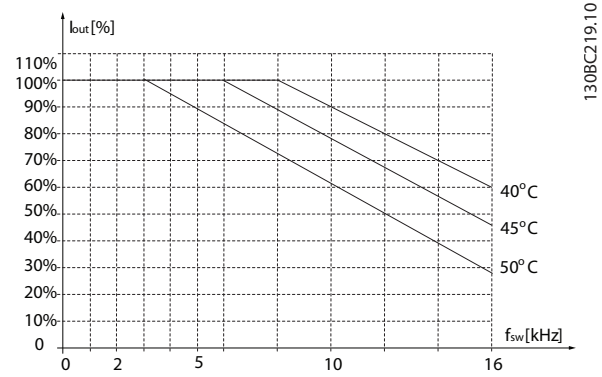

Illustration 8.3 200 V IP20 H2 2.2 kW

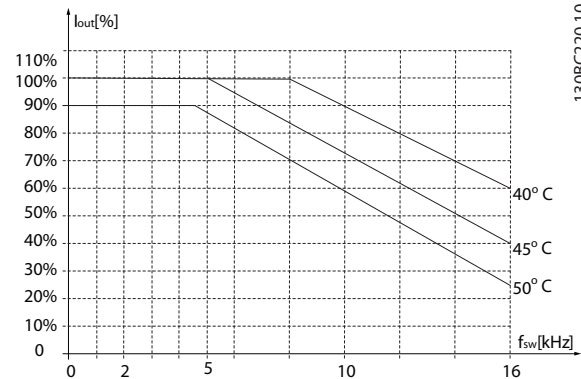

Illustration 8.4 400 V IP20 H2 2.2-4.0 kW

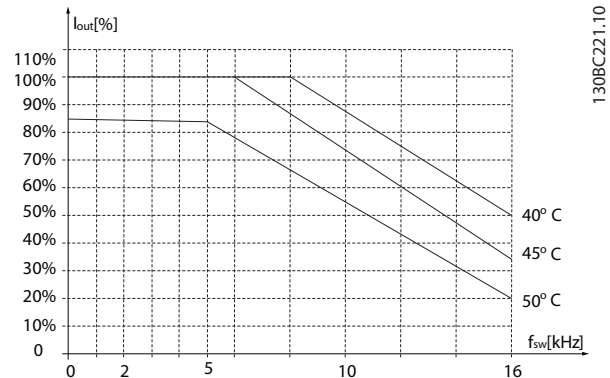

Illustration 8.5 200 V IP20 H3 3.7 kW

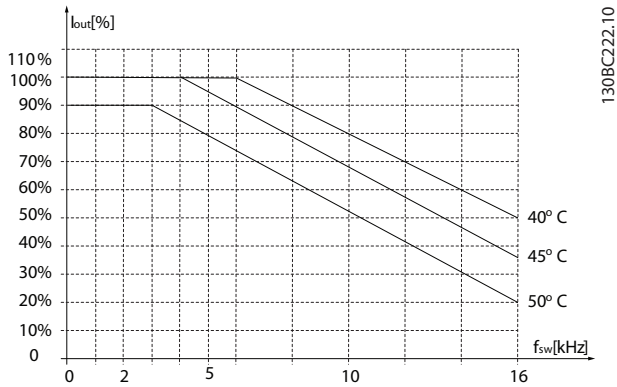

Illustration 8.6 400 V IP20 H3 5.5-7.5 kW

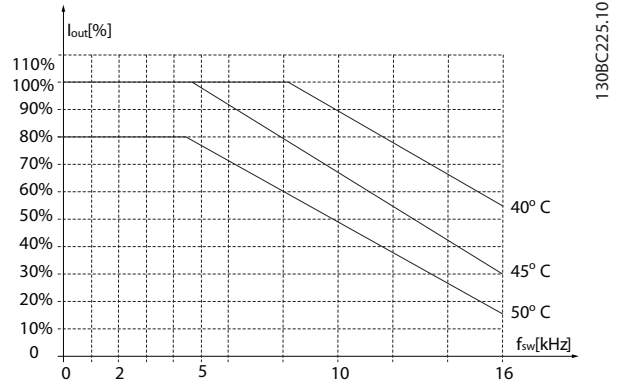

Illustration 8.9 200 V IP20 H5 11 kW

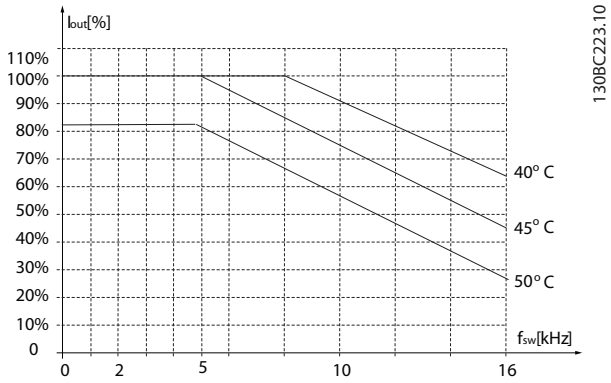

Illustration 8.7 200 V IP20 H4 5.5-7.5 kW

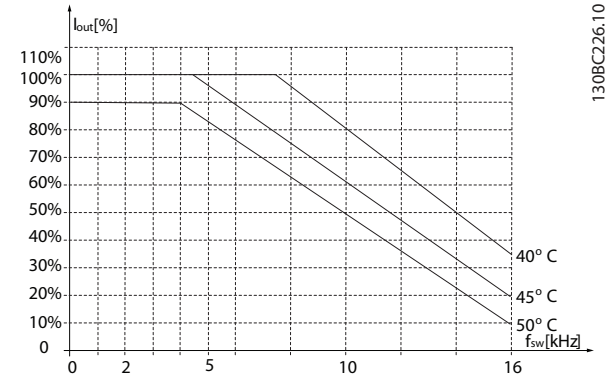

Illustration 8.10 400 V IP20 H5 18.5-22 kW

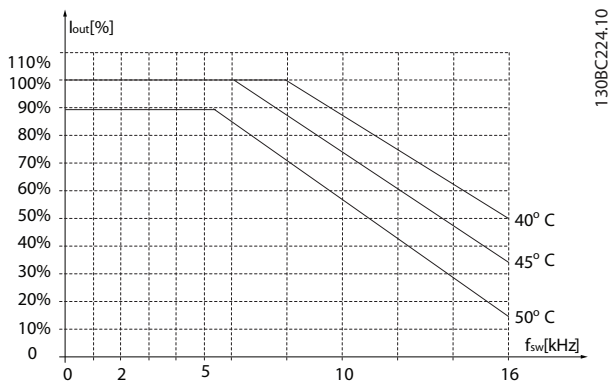

Illustration 8.8 400 V IP20 H4 11-15 kW

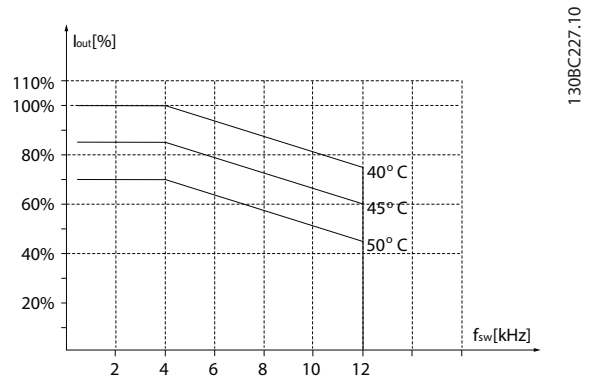

Illustration 8.11 200 V IP20 H6 15-18.5 kW

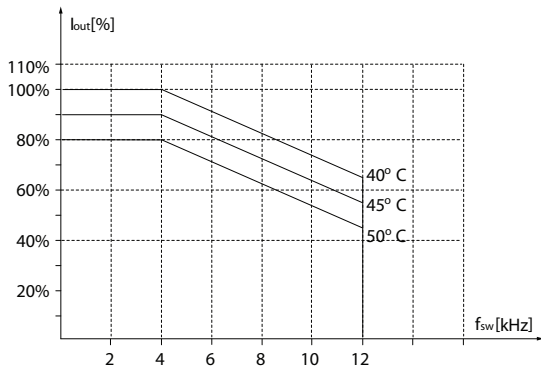

Illustration 8.12 400 V IP20 H6 30-37 kW

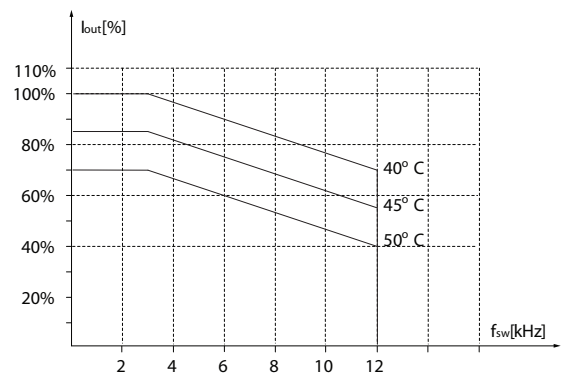

Illustration 8.15 200 V IP20 H7 22-30 kW

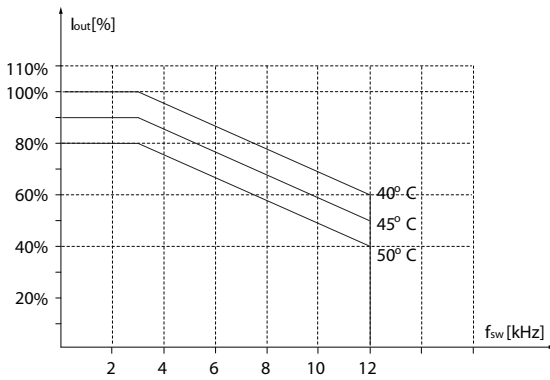

Illustration 8.13 400 V IP20 H6 45 kW

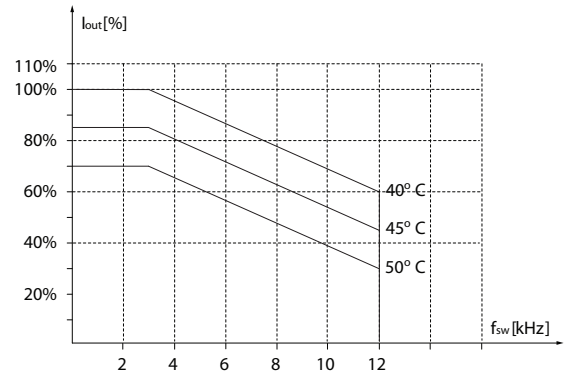

Illustration 8.16 400 V IP20 H7 55-75 kW

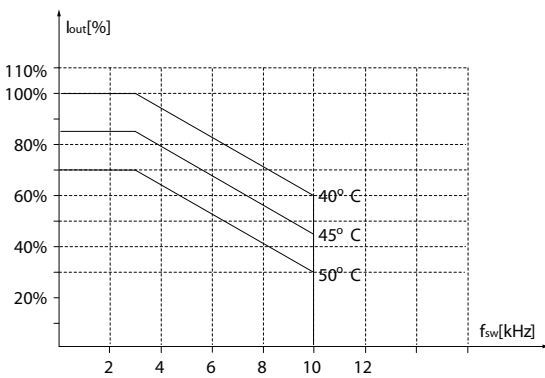

Illustration 8.14 600 V IP20 H6 22-30 kW

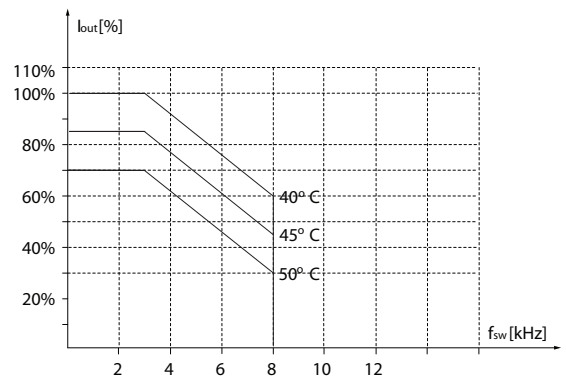

Illustration 8.17 600 V IP20 H7 45-55 kW

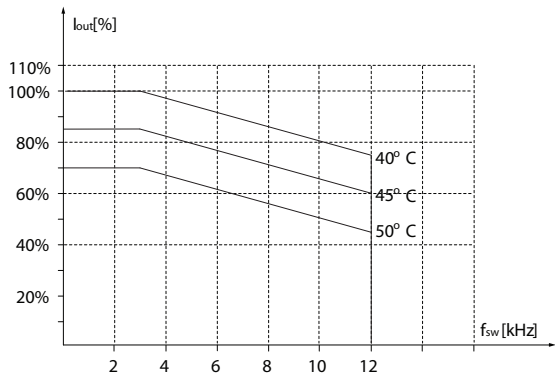

Illustration 8.18 200 V IP20 H8 37-45 kW

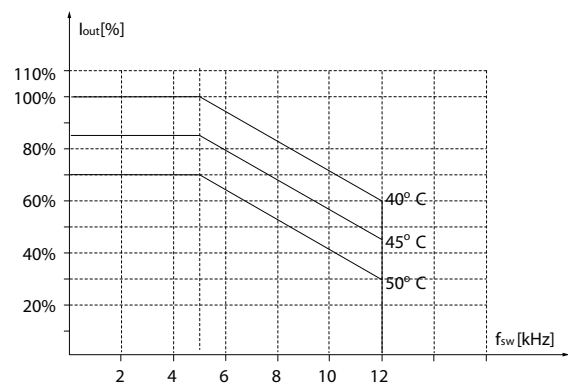

Illustration 8.21 600 V IP20 H9 2.2-3 kW

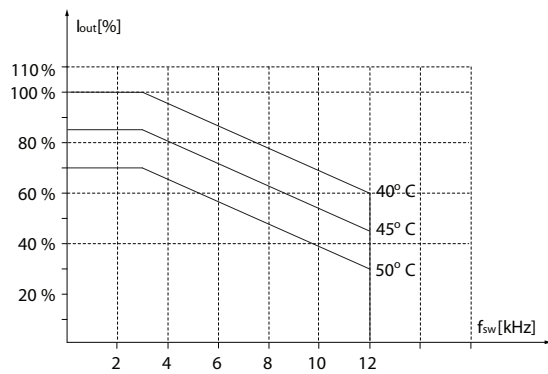

Illustration 8.19 400 V IP20 H8 90 kW

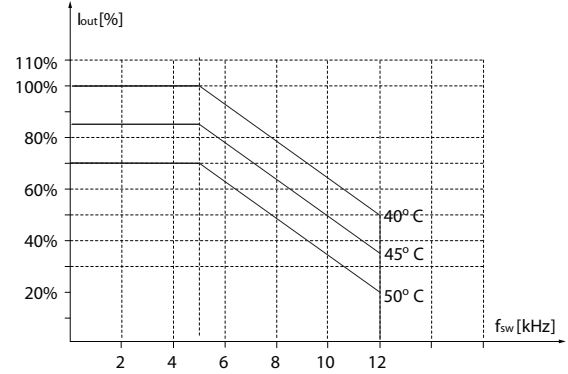

Illustration 8.22 600 V IP20 H9 5.5-7.5 kW

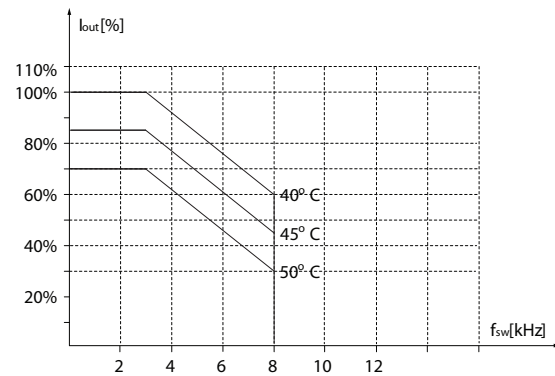

Illustration 8.20 600 V IP20 H8 75-90 kW

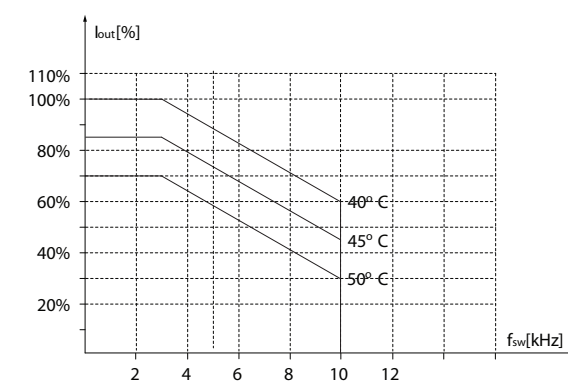

Illustration 8.23 600 V IP20 H10 11-15 kW

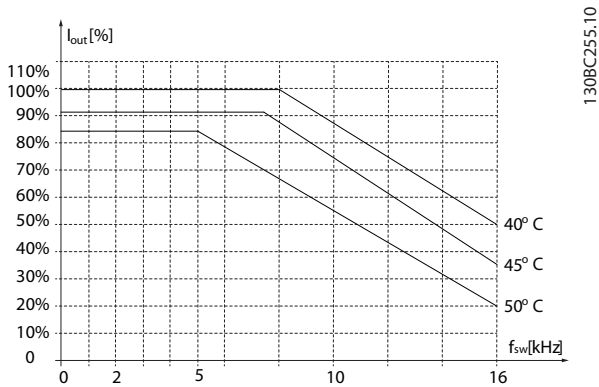

Illustration 8.24 400 V IP54 I2 0.75-4.0 kW

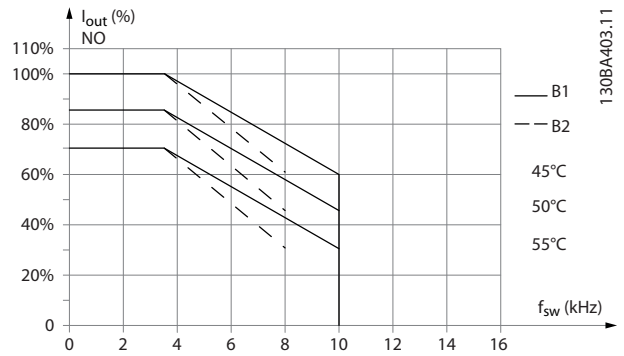

Illustration 8.27 400 V IP54 I5 11-18.5 kW

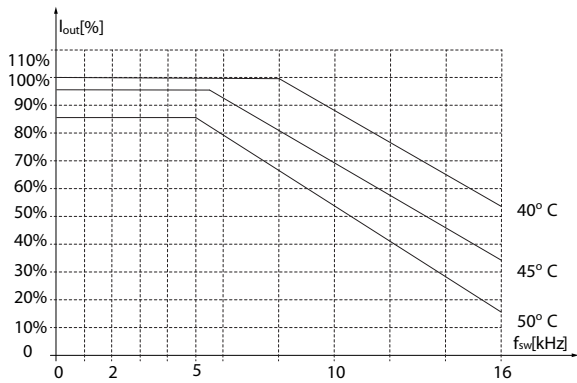

Illustration 8.25 400 V IP54 I3 5.5-7.5 kW

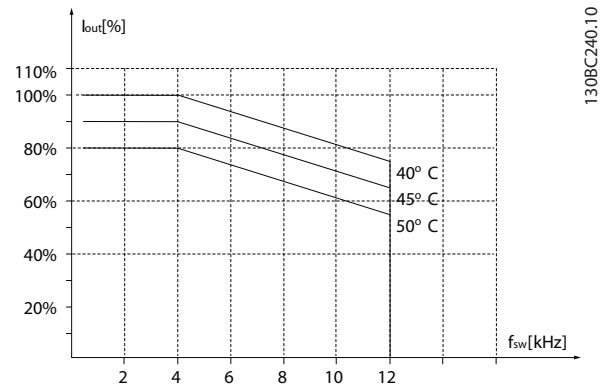

Illustration 8.28 400 V IP54 I6 22-30 kW

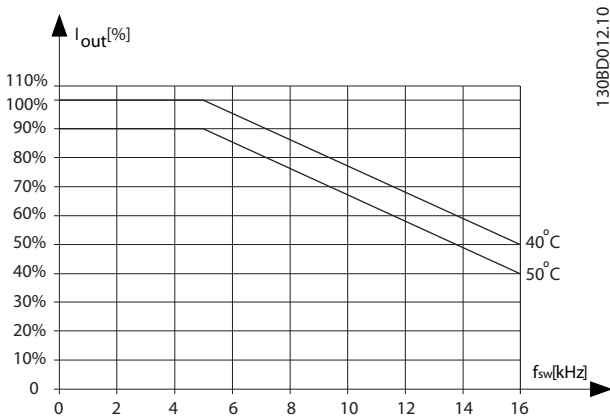

Illustration 8.26 400 V IP54 I4 11-18.5 kW

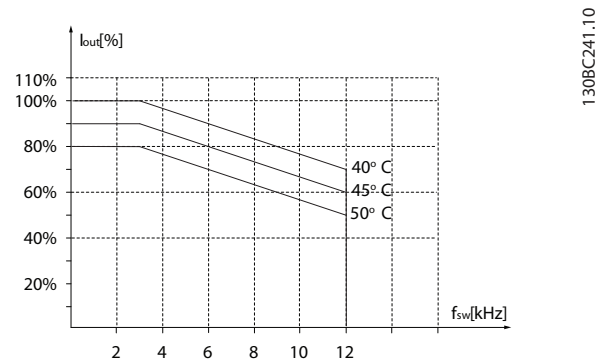

Illustration 8.29 400 V IP54 I6 37 kW

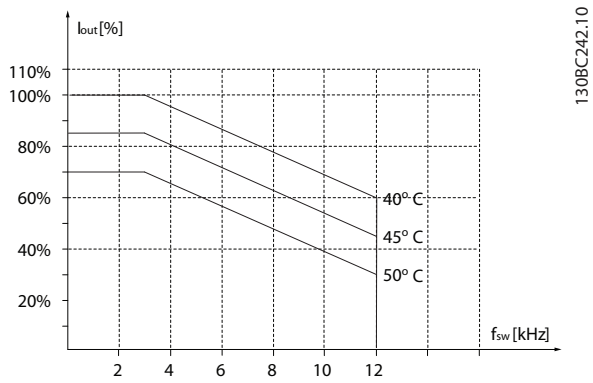

Illustration 8.30 400 V IP54 I7 45-55 kW

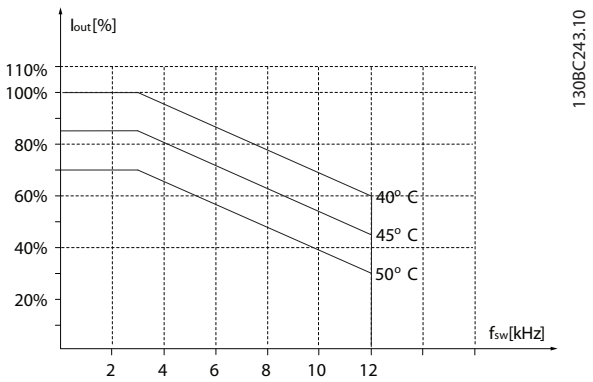

Illustration 8.31 400 V IP54 I8 75-90 kW



**Index**

**A**

Abbreviations..... 5

Acoustic Noise..... 103

Advanced Vector Control..... 6

Aggressive Environments..... 11

Air Humidity..... 11

Alpha Numeric Display..... 65

Analog  
   Inputs..... 6, 102, 6  
   Output..... 102

Application Examples..... 17

**B**

Balancing Contractor..... 22

Better Control..... 15

Break-away Torque..... 6

Building Management System, BMS..... 13

Bypass Frequency Ranges..... 20

**C**

Cable Lengths And Cross Sections..... 101

CAV System..... 19

CE Conformity And Labeling..... 10

Central VAV Systems..... 18

Changes Made..... 66, 75

Closed Loop Set-up Wizard..... 66, 27, 66

CO2 Sensor..... 19

Coasting..... 92, 6, 91

Comparison Of Energy Savings..... 13

Condenser Pumps..... 21

Connecting To Mains And Motor..... 54

Constant Air Volume..... 19

Control  
   Card, 10 V DC Output..... 103  
   Card, 24 V DC Output..... 102  
   Card, RS-485 Serial Communication..... 102  
   Potential..... 23  
   Structure Closed Loop..... 25  
   Structure Open Loop..... 24  
   Terminals..... 64  
   Word..... 91

Controlling Fans And Pumps..... 12

Cooling Tower Fan..... 20

**D**

Dampers..... 18

DANGEROUS VOLTAGE..... 9

Data Types Supported By The Frequency Converter..... 81

DC Brake..... 91

Decoupling Plate..... 42

Definitions..... 6

Differential Pressure..... 23

Digital  
   Inputs..... 101  
   Output..... 102

Discharge Time..... 10

Disposal Instruction..... 10

Drive Configurator..... 43

**E**

Earth Leakage Current..... 37

Electrical  
   Installation In General..... 53  
   Overview..... 52

EMC  
   Directive 89/336/EEC..... 11  
   Precautions..... 78

EMC-Correct Electrical Installation..... 62

Emission Requirements..... 31

Energy Savings..... 14, 12

Evaporator Flow Rate..... 22

Example Of Energy Savings..... 13

Extreme Running Conditions..... 37

**F**

FC  
   Profile..... 91  
   With Modbus RTU..... 78

Feedback Conversion..... 25

Field Mounting..... 51

Flow Meter..... 22

Freeze Output..... 6

Frequency  
   Converter Hardware Set-up..... 77  
   Converter Set-up..... 79  
   Converter With Modbus RTU..... 83

Function Codes Supported By Modbus RTU..... 87

Fuses..... 60

**G**

Galvanic Isolation..... 36

General  
   Aspects Of EMC Emissions..... 31  
   Aspects Of Harmonics Emission..... 34  
   Specifications..... 101

**H**

**Harmonics**

- Emission Requirements..... 34
- Test Results (Emission)..... 34

**Hold Output Frequency**..... 91

**How**

- To Control The Frequency Converter..... 86
- To Order..... 43
- To Programme..... 65

**I**

**IGVs**..... 18

**Immunity Requirements**..... 36

**Index (IND)**..... 81

**Initialise The Frequency Converter**..... 76

**Installation At High Altitudes**..... 9

**Intermediate Circuit**..... 37, 103

**IP21/TYPE 1 Enclosure Kit**..... 41

**J**

**Jog**..... 6, 92

**L**

**Laws Of Proportionality**..... 13

**LCP**

- LCP..... 6, 7, 24
- Copy..... 75

**Leakage Current**..... 37

**Legal Information**..... 4

**Literature**..... 4

**Local**

- (Hand On) And Remote (Auto On) Control..... 24
- Control Panel (LCP)..... 65
- Speed Determination..... 22

**Low Evaporator Temperature**..... 22

**M**

**Main Menu**..... 75

**Mains**

- Drop-out..... 37
- Supply..... 8
- Supply (L1, L2, L3)..... 101
- Supply 3x200-240 V AC..... 95
- Supply 3x380-480 V AC..... 96, 98
- Supply 3x525-600 V AC..... 100

**Manual PI Adjustment**..... 30

**Menu Key**..... 65

**Menus**..... 66

**Modbus**

- Communication..... 78
- Exception Codes..... 87
- RTU Overview..... 82

**Moment Of Inertia**..... 37

**Motor**

- Output (U, V, W)..... 101
- Phases..... 37
- Protection..... 101
- Set-up..... 66
- Thermal Protection..... 93, 37

**Motor-generated Over-voltage**..... 37

**Multiple Pumps**..... 23

**N**

**Navigation Keys And Indicator Lights (LEDs)**..... 65

**Network**

- Configuration..... 83
- Connection..... 77

**O**

**Operation Keys And Indicator Lights (LEDs)**..... 65

**Options And Accessories**..... 40, 45

**Overcurrent Protection**..... 60

**P**

**Parameter**

- Number (PNU)..... 81
- Values..... 88

**Pay Back Period**..... 14

**PELV - Protective Extra Low Voltage**..... 36

**Power Factor**..... 8

**Primary Pumps**..... 22

**Programmable Minimum Frequency Setting**..... 20

**Programming With MCT 10 Setup Software**..... 65

**Protection**

- Protection..... 11, 36, 37, 60
- And Features..... 101

**Protocol Overview**..... 78

**Public Supply Network**..... 34

**Pump Impeller**..... 21

**Q**

**Quick**

- Menu..... 66
- Transfer Of Parameter Settings Between Multiple Frequency Converters..... 75

**R**

**Rated Motor Speed**..... 6

**RCD**..... 6, 37

Read Holding Registers (03 HEX).....	89		
Read-out And Programming Of Indexed Parameters.....	75		
Recommended Initialisation.....	76		
<b>Reference</b>			
Reference.....	10		
Handling.....	26		
Relay Output.....	102		
Residual Current Device.....	37		
<b>RS-485</b>			
RS-485.....	77		
Installation And Set-up.....	77		
<b>S</b>			
<b>Safety</b>			
Note.....	9		
Regulations.....	9		
Secondary Pumps.....	23		
Serial Communication Port.....	6		
Short Circuit (Motor Phase – Phase).....	37		
Side-by-Side Installation.....	51		
Soft-starter.....	15		
Software Version.....	4		
Star/Delta Starter.....	15		
Start-up Wizard For Open Loop Applications.....	66		
<b>Status</b>			
Status.....	66		
Word.....	92		
Surroundings.....	103		
<b>Switching</b>			
On The Input Supply.....	101		
On The Output.....	37		
<b>Symbols</b> .....	5		
<b>T</b>			
Telegram Length (LGE).....	79		
<b>The</b>			
EMC Directive (89/336/EEC).....	10		
Low-voltage Directive (73/23/EEC).....	10		
Machinery Directive (98/37/EEC).....	10		
Thermistor.....	6		
Throttling Valve.....	21		
Tuning The Drive Closed Loop Controller.....	30		
Two Finger Initialization.....	76		
Type Code String.....	44		
<b>U</b>			
UL Compliance.....	60		
UNINTENDED START.....	9		
Using A Frequency Converter Saves Money.....	15		
<b>V</b>			
<b>Variable</b>			
Air Volume.....	18		
Control Of Flow And Pressure.....	15		
Varying Flow Over 1 Year.....	14		
VAV.....	18		
Vibration And Shock.....	12		
Vibrations.....	20		
WC.....	8		
<b>W</b>			
What Is Covered.....	10		
Wizard For Open Loop Applications.....	66		



[www.danfoss.com/drives](http://www.danfoss.com/drives)

---

Danfoss can accept no responsibility for possible errors in catalogues, brochures and other printed material. Danfoss reserves the right to alter its products without notice. This also applies to products already on order provided that such alterations can be made without subsequential changes being necessary in specifications already agreed. All trademarks in this material are property of the respective companies. Danfoss and the Danfoss logotype are trademarks of Danfoss A/S. All rights reserved.

---



