

JM Typhoon Inground Pool Pump

Designed for today's most demanding installations. The medium head pump has been engineered for durability and quiet performance with economy in mind. This all-around, self-priming pump with large pump basket is ideally suited for all above-ground, on-ground and small in-ground pools. Exclusive features such as high efficiency motor, 100% recyclable "environment friendly" plastics, and carbon to ceramic sealing surfaces design will make medium head pump the leading pump choice of all pool professionals.



Features

- Rugged, one-piece strainer housing molded of corrosion-proof reinforced thermoplastic for extra durability and long life
- Exclusive, high-performance motor design for quieter, cooler and more energy efficient operation
- Massive strainer basket for ease of maintenance
- See-through lid makes inspection fast and easy-engineered polymer remains clear and strong. Besides lid is easy to remove and quickly locks in place with a quarter-turn
- American design mechanical seal using carbon to ceramic sealing surfaces

- Stainless steel shaft
- High profile motor mounting base
- Fully factory tested
- Simple servicing
- Self-priming

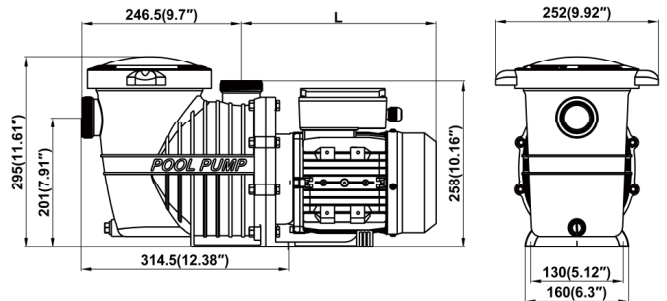

Performance Curves

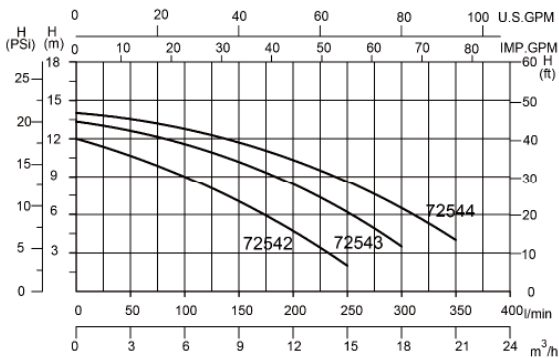

MODEL TECHNICAL DATA

Model Number	H.P.	Voltage	Pipe Size	Dim. "L"	Ctn. Qty.	Net. Weight
Single-Speed						
72542	0.75	220-240	1 1/2"	281	1	21.7 lbs.
72543	1.0	220-240	1 1/2"	316	1	26 lbs.
72544	1.5	220-240	1 1/2"	316	1	29.6 lbs.
Model Number	Description				Ctn. Qty.	Net. Weight
Optional Accessories						
91384	1 1/2" Union Connection Kit-curved				1	0.33 lb.