

[ONLINE HELP](#)

Laser Measurement Systems of the LMS100 Product Family



In full view in all weathers –
compact and economical



Software version described

Software/tool	Function	Status
Device description LMS100/111/151	Device specific software module for SOPAS ET	V 01.10.00 or higher
Device description LMS122/123	Device specific software module for SOPAS ET	V 01.10.00 or higher
SOPAS ET	Configuration software	V 02.18 or higher

Copyright

Copyright © 2008
SICK AG Waldkirch
Auto Ident, Reute Plant
Nimburger Straße 11
79276 Reute
Germany

Trademarks

Windows 2000™, Windows XP™, Windows Vista™ and Internet Explorer™ are registered trademarks of Microsoft Corporation in the USA and other countries.

Acrobat® Reader™ is a trademark of Adobe Systems Incorporated.

Table of contents

1	About this document	6
1.1	Function of this document	6
1.2	Target group	6
1.3	Depth of information	6
1.4	Symbology used	6
2	For your safety	7
2.1	Authorised personnel	7
2.2	General safety notes and protective measures	7
3	Configuration	8
3.1	Preparing the configuration	10
3.2	Basic parameters	10
3.3	Filter	13
3.4	Increment source	14
3.5	Evaluation fields	16
3.6	Evaluation cases	37
3.7	Data processing	41
3.8	Network/interfaces/inputs and outputs	42
4	Monitor	49
4.1	Field evaluation monitor	49
4.2	Field evaluation logging	50
5	Service/system status	51
5.1	LMS status	51
5.2	Contamination	51
5.3	Encoder status	52
5.4	Operating data	52
6	Quickstart mode for the LMS122/123	54
6.1	Monitored areas	54
6.2	Response behaviour	55
6.3	Alarm message	56
6.4	Malfunction message	56
6.5	General	56
6.6	Field evaluation monitor	57
7	Glossary	58
8	Index	59

Abbreviations

BCC	Block character check
CAN	Controller area network = standardised fieldbus system with message-based protocol for exchanging data
CS	Checksum
EEPROM	Electrically erasable programmable read-only memory
HTML	Hypertext markup language = page description language on the Internet
LED	Light Emitting Diode
LMS	SICK AG laser measurement system
RAM	Random access memory = volatile memory with direct access
ROM	Read-only memory (permanent)
SOPAS ET	SICK OPEN PORTAL for APPLICATION and SYSTEMS ENGINEERING TOOL = configuration software for the configuration of the LMS100/LMS111/LMS120

Tables

Tab. 1:	Passwords LMS100/111/151	8
Tab. 2:	Passwords LMS122/123	8
Tab. 3:	Buttons for managing the evaluation fields	16
Tab. 4:	Buttons for changing the field editor view	18
Tab. 5:	Buttons for managing the evaluation cases	37
Tab. 6:	Input combination examples	38
Tab. 7:	Buttons for controlling the field evaluation logging	50
Tab. 8:	Buttons for managing the evaluation fields	55

Figures

Fig. 1:	Starting angle and stopping angle for the measurement	11
Fig. 2:	Effect of the digital filters	13
Fig. 3:	Selection of the method for adding an evaluation field	17
Fig. 4:	Selection of the method for adding an evaluation field for the LMS122/123 ..	17
Fig. 5:	Enlarging the field editor view with the mouse	19
Fig. 6:	Setting end points for a field	19
Fig. 7:	Setting end points – step 1	20
Fig. 8:	Setting end points – step 2	20
Fig. 9:	Moving end points – step 1	21
Fig. 10:	Moving end points – step 2	21
Fig. 11:	Deleting end points – step 1	22
Fig. 12:	Deleting end points – step 2	22
Fig. 13:	Start points for a field	23
Fig. 14:	Moving a rectangular field	24
Fig. 15:	Increasing or reducing the size of a rectangular field	24
Fig. 16:	Rotating a rectangular field	25
Fig. 17:	Editing entries for rectangular evaluation field	25

Fig. 18: View of a dynamic field in the field editor 26

Fig. 19: Moving a dynamic field 26

Fig. 20: Enlarging or reducing the basic field for a dynamic evaluation field 27

Fig. 21: Increasing or decreasing the maximum length of a dynamic evaluation field .. 27

Fig. 22: Editing dynamic evaluation field entry 28

Fig. 23: Start angle and end angle for teaching-in an evaluation field 29

Fig. 24: Radial distance of an evaluation field to the scanned contour 29

Fig. 25: Distance to the start points for a taught-in field 31

Fig. 26: Start angle and end angle during teach-in 32

Fig. 27: Distance to the start points for a taught-in field 33

Fig. 28: Distance to the start points for a manually edited field 34

Fig. 29: Start angle and end angle during teach-in 35

Fig. 30: Distance to the start points for a taught-in field 36

Fig. 31: Distance-dependent pixel evaluation 39

Fig. 32: Distance-dependent evaluation of two objects 40

Fig. 33: Selection of the indication on the monitor 49

1 About this document

Please read this chapter carefully before working with this documentation and the LMS laser measurement system.

1.1 Function of this document

This document provides **technical personnel** information on the configuration and diagnostics on the LMS laser measurement system using the SOPAS ET configuration software.

1.2 Target group

The target group for this document are people such as technicians, service technicians and engineers who configure and perform diagnostics on the LMS.

1.3 Depth of information

This document contains information on the configuration, diagnostics and troubleshooting on the LMS laser measurement system with the aid of the SOPAS ET configuration software.

Planning and using measurement systems such as the LMS also require specific technical skills which are not detailed in this documentation.

When operating the LMS laser measurement system, the national, local and statutory rules and regulations must be observed.

1.4 Symbology used

Reference	Text in <i>italics</i> indicates a reference to more detailed information.
Recommendation	Recommendations are designed to give you assistance in the decision-making process with respect to a certain function or a technical measure.
Important	Sections marked "Important" provide information about special features of the device.
Explanation	Explanations provide background knowledge on technical relationships.
MENU COMMAND	This typeface indicates a term in the SOPAS ET user interface.
Terminal output	This typeface indicates messages that the LMS outputs via its terminal interface.
➤ Take action ...	Instructions for taking action are shown by an arrow. Read carefully and follow the instructions for action.



This symbol refers to additionally available documentation.



WARNING

Warning!

A warning indicates an actual or potential hazard. They are designed to help you to prevent accidents and to protect the device from being damaged.

Read carefully and follow the warning notices!



Software notes show you where the related setting can be made in SOPAS ET.

2 For your safety

This chapter deals with your own safety and the safety of the equipment operators.

- Please read this chapter carefully before configuring the LMS.

2.1 Authorised personnel

The LMS laser measurement system must be configured and commissioned only by adequately qualified personnel.

The following qualifications are necessary for the various tasks:

- knowledge on the use and operation of devices in the related application (e.g. conveyors)
- knowledge on the software and hardware environment in the related application (e.g. conveyors)
- basic knowledge of the Windows operating system
- basic knowledge of an HTML browser (e.g. Internet Explorer)
- basic knowledge of data transmission

2.2 General safety notes and protective measures



WARNING

Safety notes

Please observe the following items in order to ensure the correct and safe use of the LMS laser measurement system.

- The notices in this online help (e.g. on use, mounting, installation or integration into the existing machine controller) must be observed.
- National/international rules and regulations apply to the installation, commissioning, use and periodic technical inspections of the laser measurement system, in particular:
 - the work safety regulations/safety rules
 - other relevant health and safety regulations
- Manufacturers and users of the system are responsible for obtaining and observing all applicable safety regulations and rules.
- The tests must be carried out by specialist personnel or specially qualified and authorised personnel and must be recorded and documented to ensure that the tests can be reconstructed and retraced at any time.

3 Configuration

The LMS laser measurement system is adapted to the on-site measurement situation by means of the configuration. You can configure and test the measurement properties, the analysis behaviour and the output properties of the system as required.

NOTICE

Do not switch off the voltage supply during configuration!

Switching off the voltage supply during configuration causes all parameters already configured to be lost.

Password protection LMS100/111/151

Software access to the LMS100/111/151 is password protected. As supplied the following passwords are defined:

User level	Password
Maintenance personnel	main
Authorised client	client

Tab. 1: Passwords LMS100/111/151

Password protection LMS122/123

Software access to the LMS122/123 is password protected. As supplied the following passwords are defined:

User level	Password
Operator	-
Operator	main
Integrator	client

Tab. 2: Passwords LMS122/123

A password is not defined for the Operator user level as supplied.

- Recommendation**
- Enter a password word for the Operator user level to protect the LMS122/123 against access!

How to login to the LMS:



- From the TOOLS menu select the LOGIN DEVICE... command.
- In the LOGIN dialogue, select the USER LEVEL and enter the PASSWORD.

How to change a password:



Only possible with device switched online.

- In the LMS... menu, select the PASSWORD, CHANGE command.
- Then enter the new PASSWORD.

Expert mode or Quickstart

For the LMS122/123 a Quickstart configuration mode is available with the aid of which the parameters for the LMS122/123 can be configured for the needs of object protection (see [Chapter 6 "Quickstart mode for the LMS122/123" on page 54.](#))

For the LMS100/111/151 only the Expert mode is available. The Expert mode can also be used for the LMS122/123.

Save parameters permanently

The data are initially saved in the RAM of the LMS so that you can check the effect immediately. On completion of the configuration, you must save the parameters permanently in the EEPROM of the LMS.

How to save the parameters permanently in the LMS:



- From the LMS... menu, choose the command PARAMETER, SAVE PERMANENTLY.
In this way the parameters are saved in the EEPROM in the LMS and will also be available after the device is switched off and on again.

Save configuration

The configuration data can be saved in a project file so they can be transferred, for example, to an identical LMS. Additionally, you can save the configuration data as PDF.

How to save the configuration data to a file or as PDF:



- From the PROJECT menu, choose the command SAVE PROJECT.
- From the PROJECT menu, choose the command PRINT, SAVE AS PDF.

Resetting configuration

Recommendation

To reset the LMS to the default delivery status, you should first export the device data to a file from a device that is in the default delivery status. You can then subsequently load these device data into an already configured device to reset its configuration to the default delivery status.

How to reset the configuration of the LMS:



- In the PROJECT menu, choose the command EXPORT DEVICE.
- Save the SOPAS ET device file on a suitable drive, e.g. as BASIC_CONFIGURATION.SDV.
- On an already configured device, choose on the EDIT menu, the LOAD DEVICE DATA TO PROJECT command.
- Choose the device data saved, e.g. as BASIC_CONFIGURATION.SDV.

The parameters for the LMS are overwritten with the parameters from the default delivery status.

3.1 Preparing the configuration

To configure the LMS laser measurement system, you need:

- SOPAS ET configuration software on CD-ROM
- PC/notebook (not in the delivery)
 - with a standard Intel Pentium PC or compatible, at least Pentium III, 500 MHz
 - minimum 256 MB RAM, 512 MB RAM recommended
 - data interface RS-232 or Ethernet
 - operating system: MS Windows 2000, XP or VISTA
 - monitor with 256 colours minimum, 65.536 colours recommended (16 Bit High Color), screen resolution 800 × 600 minimum
 - hard disc: minimum 170 MB free memory
 - CD-ROM drive
 - HTML browser on PC, e.g. Internet Explorer™, for the online help system for SOPAS ET
- connecting cable between PC and LMS

How to prepare the configuration:

- Ensure that the LMS laser measurement system has been correctly assembled and that the electrical connections are also correct.
- Plan all the necessary adjustments.
- Install the provided SOPAS ET configuration software from CD-ROM.

3.2 Basic parameters

3.2.1 Current configuration

The CURRENT CONFIGURATION area indicates the currently set scan frequency and angular resolution.

Important Values are only displayed if you configure a device online, that is the PC is connected to the device.

How to display the current device parameters:

- In the PROJECT TREE, LMS..., PARAMETER, open the device page BASIC PARAMETERS.

The CURRENT CONFIGURATION area indicates the currently set SCAN FREQUENCY and ANGULAR RESOLUTION.



3.2.2 New configuration

In the NEW CONFIGURATION area you can configure the scanning frequency and the angular resolution and transfer these parameters to the LMS.

Scanning frequency

The LMS scans with a scanning frequency of 25 or 50 Hz. At the higher scanning frequency the LMS supplies more measured values per time unit.

Angular resolution

The LMS scans with an angular resolution of 0.25° or 0.50°. At the finer angular resolution, the LMS supplies more measured values per scan.

Valid combinations and return values

There are three valid combinations of scanning frequency and angular resolution:

- 50 Hz and 0.5°
- 25 Hz and 0.5°
- 25 Hz and 0.25°

After the transfer of the values the LMS may return an error value to SOPAS ET in certain circumstances. This situation has the following possible meanings:

- no error, parameters have been accepted by the LMS
 - invalid scanning frequency
 - invalid angular resolution
 - invalid combination
- If an invalid value is returned, then check the scanning frequency or/and angular resolution entry.

Starting angle and stopping angle of the scan area

The LMS can scan a maximum scan area of 270°.

- The starting angle is -45°.
- The stopping angle is 225°.

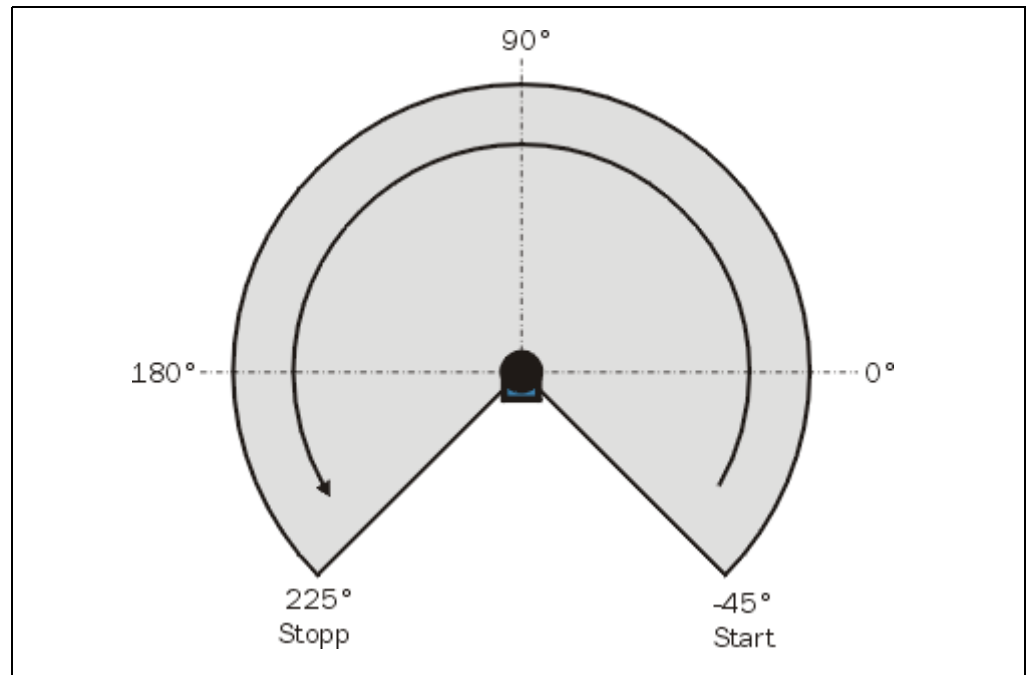

Fig. 1: Starting angle and stopping angle for the measurement

Fig. 1 shows the scan area with starting angle and stopping angle.

Objects outside the scan area are not measured or detected. Evaluation fields can only be configured within the scan area (see [section 3.5.4 "Setting end points for a segmented field" on page 19](#)).

How to change the device parameters:

- In the PROJECT TREE, LMS..., PARAMETER, open the device page BASIC PARAMETERS.
- Enter the new parameters in the NEW CONFIGURATION area and click the TRANSFER button.
The parameters are transferred to the LMS, the result of the transfer is displayed in the RETURN VALUE field as a code.

3.2.3 Measurement

You can start and stop the LMS measurement manually or switch to the stand-by mode. As an alternative you can start the measurement automatically when the LMS is started.

How to start and stop the measurement:

- In the PROJECT TREE, LMS..., PARAMETER, open the device page BASIC PARAMETERS.
- In the MEASUREMENT area, click the START button.
The measurement will be started.
- In the MEASUREMENT area, click the STOP button.
The measurement will be stopped.
- In the MEASUREMENT area, click the STAND BY button.
Measurement is stopped, but the LMS's motor continues to rotate, measurement can be started immediately.

3.2.4 Contamination measurement

The contamination measurement for the optics cover can be configured in SOPAS ET. The result of the measurement can be read from the LMS using a message (see [chapter "Annex" in the operating instructions for the LMS](#)). In addition the contamination is displayed in SOPAS ET on the SERVICE device page (see [section 5.2 "Contamination" on page 51](#)).

To configure the contamination measurement, first define a strategy. The following strategies can be selected:

- inactive
no contamination measurement
- highly available
highest contamination tolerance
- available
medium contamination tolerance
- sensitive
lowest contamination tolerance

For the strategy you must define the response time for the contamination measurement between 0 s and 60 s. If, for instance, you enter 5 s, then the device only switches to the fault state after 5 s. It is therefore possible for contamination, e.g. due to snow, to wipe away.

You can also define the thresholds from which a contamination warning or a contamination error is output.

For the two thresholds you must enter the remaining visibility in %.



How to configure the contamination measurement:

- In the PROJECT TREE, LMS..., PARAMETER, open the device page BASIC PARAMETERS.
- In the CONTAMINATION MEASUREMENT area, define the required parameters.

3.3 Filter

The LMS100 has digital filters for the pre-processing and optimisation of the measured distance values.

The sensitivity of the LMS is basically set such that the reflected pulse produced by the LMS's optics cover is filtered out of the measured result. As a result contamination of the optics cover is also filtered out to a certain extent. The LMS is therefore insensitive in the extreme near range (0 ... 30 cm (0 to 11.81 in)).

In addition you can configure either a fog filter, a hardware blanking window or an n-pulse-to-1-pulse filter.

Which filter is suitable for which application is dependent on the related measurement and evaluation task and the ambient conditions.

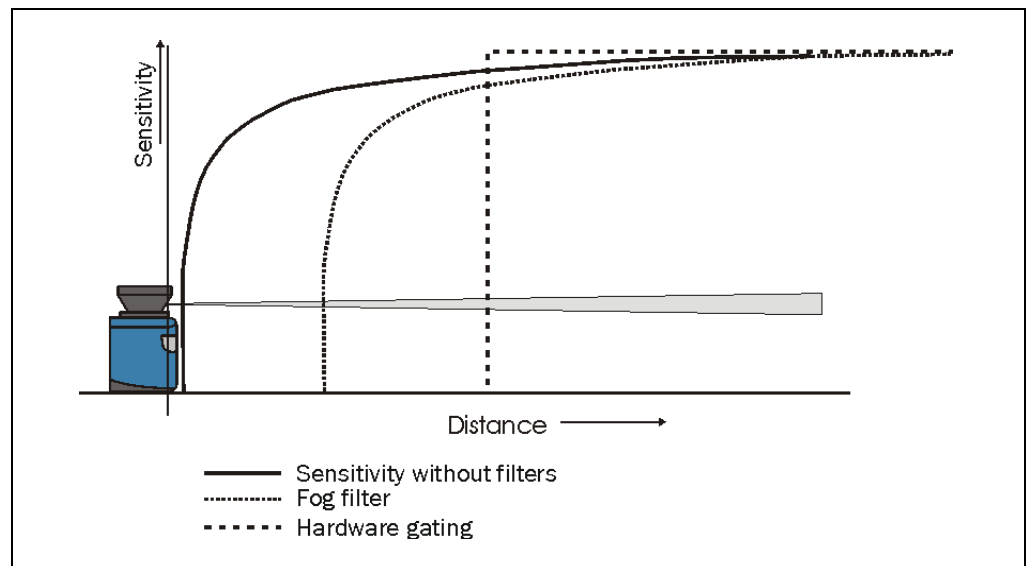

Fig. 2: Effect of the digital filters

Fog filter

The fog filter suppresses possible glare due to fog. The LMS becomes less sensitive in the near range (up to approx. 4 m (13.12 ft)) with the fog filter.

Hardware blanking window

Using the blanking window an area in front of the LMS is completely blanked. As a result the LMS only supplies measured values from a configured distance. You can configure a blanking window from 1 to 15 m (3.28 to 49.21 ft).

N-pulse-to-1-pulse filter

If two pulses are reflected by two objects during a measurement (drops of rain or edges etc.), the filter initially filters out the first reflected pulse. The value for the 2nd reflected pulse is then output as the 1st reflected pulse.



How to configure filters for the measurement:

- In the PROJECT TREE, LMS..., PARAMETER, BASIC PARAMETERS, open the device page FILTER.
- Activate the required filter in the GENERAL FILTER area.

3.3.1 Field evaluation filters

Field evaluation filters act on the field application, not on the measured value output.

Particle filter

The particle filter can be used in dusty surroundings or in case of rain or snow to filter out interference due to particles of dust, rain drops, snow flakes etc.

The filter compares each measured value with the measured value at the same angle in the previous scan and the measured values for the neighbouring angles in the previous scan.

If the difference between the measured value measured and the measured values used for the comparison exceeds a certain threshold, the measured value is evaluated as interference and is not taken into account.

How to configure filters for the field application:



- In the PROJECT TREE, LMS..., PARAMETER, BASIC PARAMETERS, open the device page FILTER.
- Activate the required filter in the FIELD EVALUATION FILTER area.

3.3.2 Scan data output filter

Mean filter

The mean filter acts on the scan data output, not on the field application. With the mean filter active, you can configure the number of scans from which the mean is formed.

The mean filter reduces the scan data output (not a smoothing mean). If the mean from 10 scans is formed, scan data are only output after each 10th scan.

3.4 Increment source

The LMS can be used, e.g. on vehicles, or measurements can be made on moving objects, e.g. on a conveyor system. In these cases the velocity of the vehicle or the object can be configured or measured.

Evaluation fields can also be modified dynamically, e.g. to implement vehicle monitoring (see [3.5.7 on page 26](#)) or the de-bounce times on the digital outputs can be controlled as a function of the track (see [3.8.9 on page 46](#)).

To be able to use these functions, configure ...

- the encoder type
- the increment source parameters

3.4.1 Encoder

The LMS can use the pulses from an encoder to determine the position or velocity.

You can use the following encoders:

- single-channel, is only connected to INC1, no direction detection
 - Dual-channel, is connected to INC1 and INC2, the pulses have a phase offset of 90°, as a result direction detection is possible.
- Then enter the resolution of the encoder in mm/increment in the ENCODER RESOLUTION input field.

How to configure the encoder type:



- In the PROJECT TREE, LMS..., PARAMETER, open the device page INCREMENT CONFIGURATION.
- Choose in the ENCODER area in the ENCODER SETTINGS selection field the encoder connected and enter the necessary parameters.

3.4.2 Increment

Select one of the following increment sources:

- constant velocity
No encoder is connected. The vehicle moves at constant speed. Enter this velocity in SOPAS ET.
- encoder
The pulses from an encoder connected to the inputs on the LMS. You can enter the resolution for this encoder in the configuration for the encoder (see [3.4.1 on page 15](#)).

How to configure the increment source:







- In the PROJECT TREE, LMS..., PARAMETER, open the device page INCREMENT CONFIGURATION.
- Choose in the INCREMENT area in the INCREMENT SOURCE selection field the required source and enter the necessary parameters.

3.5 Evaluation fields

With the aid of the field application integrated into the LMS100, up to ten evaluation fields can be configured. The existing evaluation cases are displayed in a table in the EVALUATION CASES OVERVIEW area.

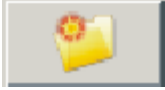
The table shows along with the number and name of the related evaluation field, the evaluation case to which the evaluation field is linked.

You can run the following functions using the buttons above the table:

Symbol	Meaning	Comment
	Create evaluation field	Using this button you can create a new evaluation field. The assistant for adding a new evaluation field is opened (see 3.5.1 on page 17).
	Edit evaluation field	You can edit an existing evaluation field using this button. ➤ For this purpose mark one of the evaluation fields in the table and then click the button.
	Copy evaluation field	You can copy an existing evaluation field using this button. During this process, all parameters in the existing field are copied to the new field. ➤ For this purpose mark one of the evaluation fields in the table and then click the button.
	Delete evaluation field	You can delete an existing evaluation field using this button. ➤ For this purpose mark one of the evaluation fields in the table and then click the button. An evaluation case in which the evaluation field is used is invalid (see 4.1 on page 49)!

Tab. 3: Buttons for managing the evaluation fields

How to configure the fields of the LMS:

- In the PROJECT TREE, LMS..., PARAMETER, open the device page EVALUATION FIELDS.
In the EVALUATION CASES OVERVIEW area you can create, copy, edit or delete fields.



3.5.1 Basic parameters for the field

In the first step of the assistant you define the name of the evaluation field and its type. The type determines how you draw or create the evaluation field in the next step.

- segmented
The evaluation field is added in segments. For this purpose set each separate point for the field using the mouse (see [section 3.5.4 “Setting end points for a segmented field” on page 19](#)).
- rectangular
It only possible to add rectangular evaluation fields. Enter the coordinates of the field (see [section 3.5.6 “Creating and editing a rectangular field” on page 23](#)).
- dynamic
Using dynamic fields you can realise speed-dependent fields, e.g. for vehicle monitoring. It only possible to add rectangular evaluation fields. For this purpose you enter the coordinates of the field, the minimum and the maximum physical size of a field (see [section 3.5.7 “Creating and editing a dynamic field” on page 26](#)).

3.5.2 Using the field editor

Using the field editor you can ...

- create an evaluation field manually using the drawing tools. You have several ways of undertaking this action, see:
 - [section 3.5.4 “Setting end points for a segmented field” on page 19](#)
 - [section 3.5.5 “Setting start points for a field” on page 23](#)
 - [section 3.5.6 “Creating and editing a rectangular field” on page 23](#)
 - [section 3.5.7 “Creating and editing a dynamic field” on page 26](#)
- teach-in an evaluation field with the aid of the LMS (see [section 3.5.8 “Teaching-in an evaluation field” on page 29](#)).
- teach-in the reference contour for an evaluation field (see [section 3.5.9 “Defining the contour as a reference” on page 32](#)).

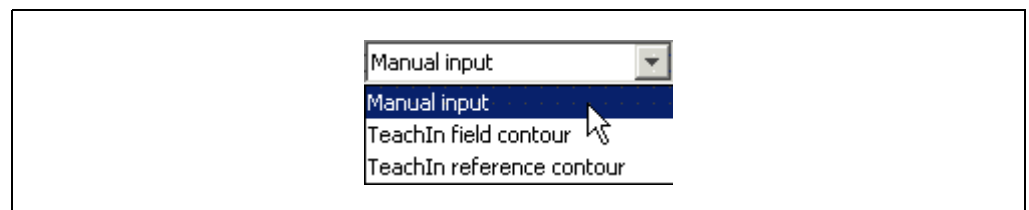

Fig. 3: Selection of the method for adding an evaluation field

- and in addition on the LMS122/123, teach-in the room contour for tamper protection (see [section 3.5.10 “Teach-in tamper protection” on page 35](#)).

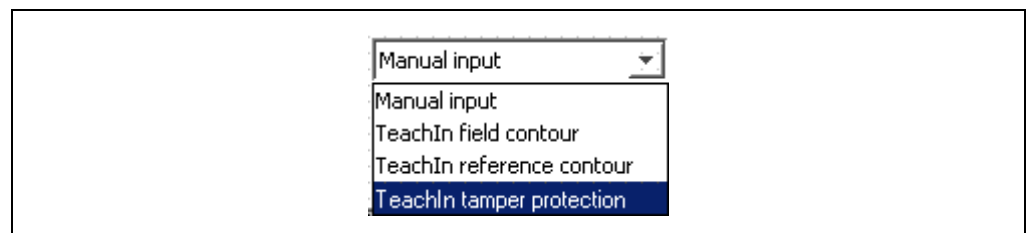





Fig. 4: Selection of the method for adding an evaluation field for the LMS122/123

3.5.3 Adapting the field editor view

To be able to work optimally with the field editor, you can change the screen layout.

Symbol	Meaning	Comment
	Zoom in/zoom out	<p>Using these buttons you can make the following changes to the view.</p> <ul style="list-style-type: none"> • zoom in • zoom out • zoom in/zoom out on all active points of the field or the scanned contour • zoom in/zoom out on the maximum field of view of the LMS
	Rotate view	<p>You can rotate the field editor view using the input field or the buttons beside the input field. In this way you can change the view, for example, to suit your application.</p> <ul style="list-style-type: none"> ➤ Enter the angle of rotation for the view in the input field. Or ➤ Change the angle of rotation of the view in steps using the arrow buttons beside the field on the right.
	Change coordinate system/mirror view	<p>Using these buttons you can make the following changes to the view:</p> <ul style="list-style-type: none"> • change between cartesian and polar view • mirror the view on the LMS, i.e. you no longer see the LMS from above, but from below
	Show	<ul style="list-style-type: none"> • show scan line of the LMS • display measurement contour as a line or as individual points • show other fields, you can then see the existing fields as a contour

Tab. 4: Buttons for changing the field editor view

In addition you can zoom in by dragging a rectangle around the objects on which you want to zoom.

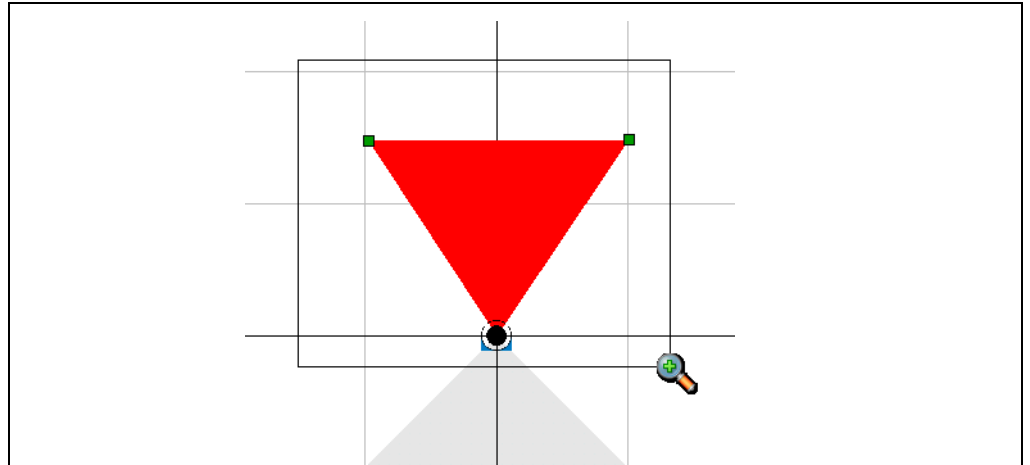

Fig. 5: Enlarging the field editor view with the mouse

3.5.4 Setting end points for a segmented field

First set the end points for a segmented evaluation field. The end points represent the outer limit of the evaluation field. In this step the evaluation field starts at the laser measurement system. If the evaluation field is only to start a certain distance from the laser measurement system, start points must be set in the following step (see [section 3.5.5 "Setting start points for a field" on page 23](#)).

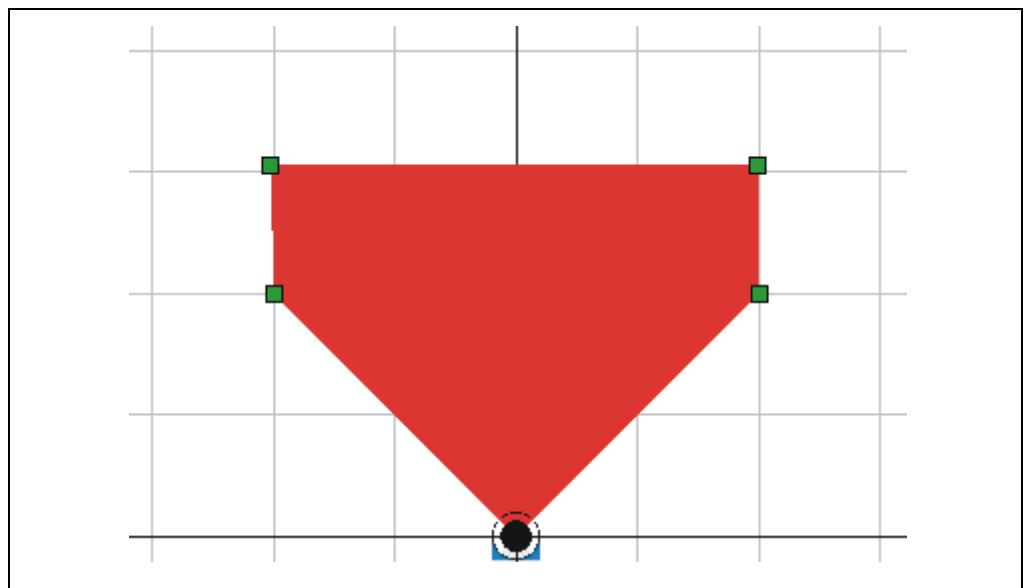

Fig. 6: Setting end points for a field

How to set end points:

Fig. 7: Setting end points – step 1

**Important**

- On the toolbar click the symbol shown.
- Move the mouse pointer over the coordinate field in the evaluation field editor. The possible point is displayed in yellow.
- You can only set points in the measurement area of the LMS (50 m (164.04 ft)).
- Click the position where you want to set the point. The point set is displayed as a green square.
- Move the mouse pointer to the next point on the field. The field you are creating is displayed in yellow.

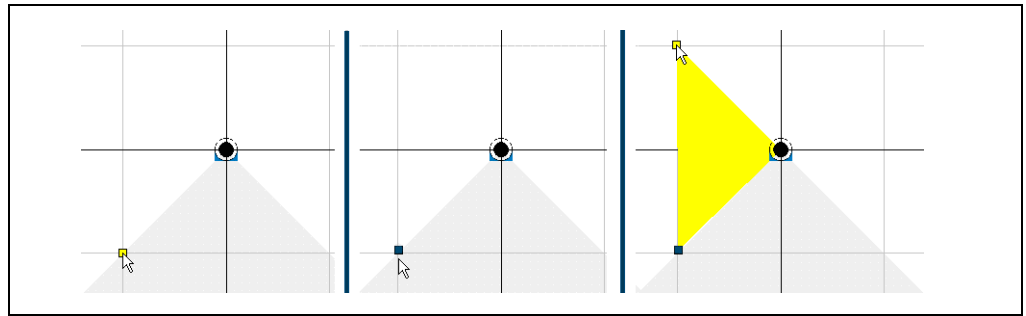
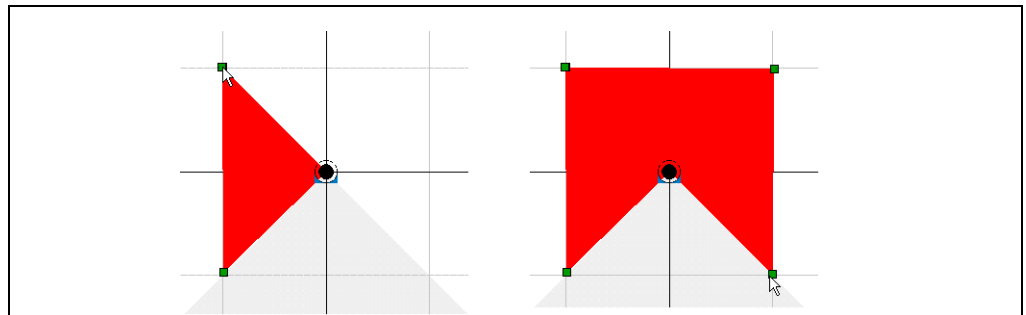

Fig. 8: Setting end points – step 2

- Click the position where you want to set the point. The resulting field is shown in red.
 - Complete the field by setting further points.
- Explanation**
- The coordinates of the mouse pointer are shown in the fields in the COORDINATE area.
 - The coordinates of the points set are shown in the FIELD POINTS area.

How to move end points:

You can move one end point individually or several end points at the same time.

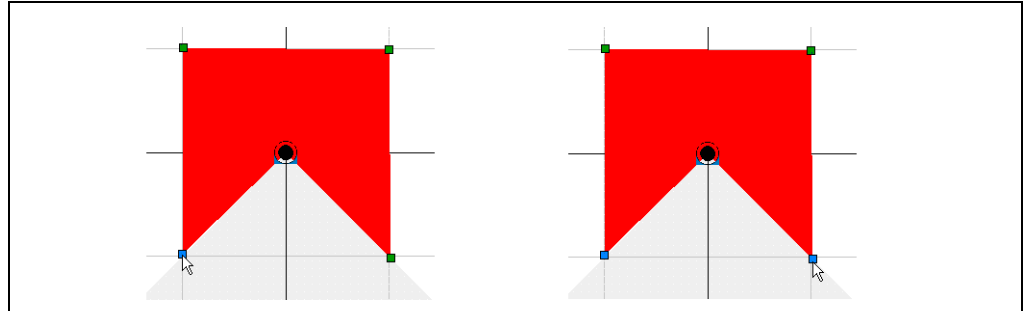

Fig. 9: Moving end points – step 1



- On the toolbar click the symbol shown.
- Click one of the points for the evaluation field.
Or:
- Keep the `Ctrl` key pressed and click on several points of the evaluation field.
Or:
- Drag a rectangle around the required points of the evaluation field using the mouse. The points are marked in blue.

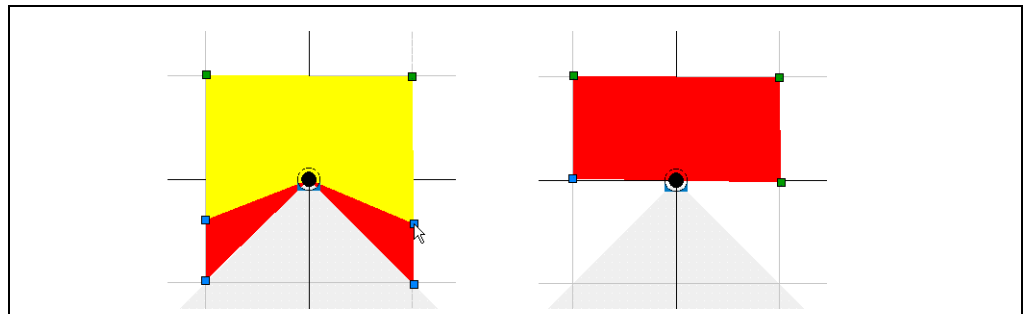

Fig. 10: Moving end points – step 2

- Keep the left mouse button pressed and move the point or points. The field you are creating is displayed in yellow.
- Release the left mouse button at the position where you want to position the points. The field now produced is again shown in red.
Or:
- Move the points of the evaluation field up, down, right or left using the arrow keys. The field you are creating is displayed in yellow.
- Press the Return key. The field now produced is again shown in red.

How to delete end points:

You can delete one end point individually or several end points at the same time.

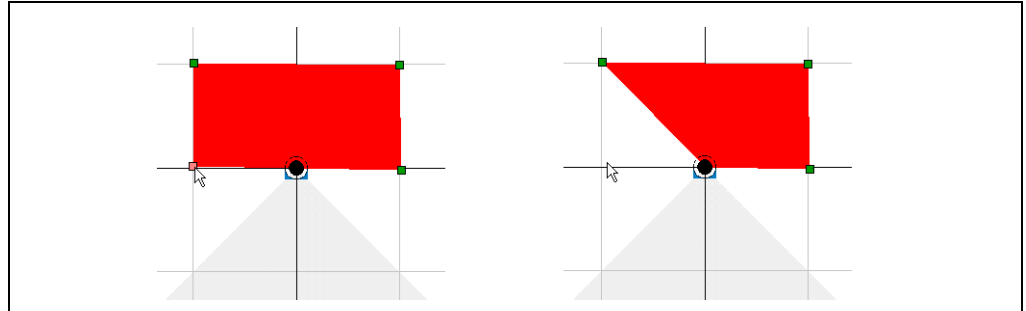

Fig. 11: Deleting end points – step 1



- On the toolbar click the symbol shown.
- Double-click one of the points for the evaluation field.
The point is deleted.

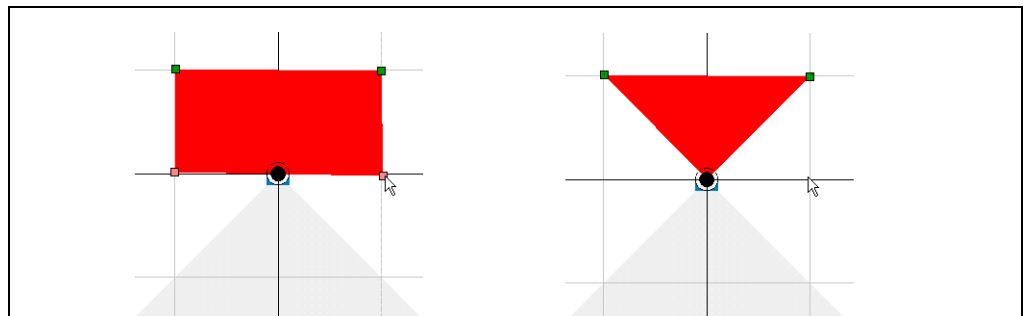

Fig. 12: Deleting end points – step 2

Or:

- Keep the **Ctrl** key pressed and click on several points of the evaluation field.
- Or:
- Drag a rectangle around the required points of the evaluation field using the mouse.
The points are marked in red.
 - Press the **Del** key.
The points are deleted.

3.5.5 Setting start points for a field

By setting start points you can implement fields that only start a certain distance from the laser measurement system. Using such fields it is, for instance, possible, to walk or drive through the area between the laser measurement system and the evaluation field.

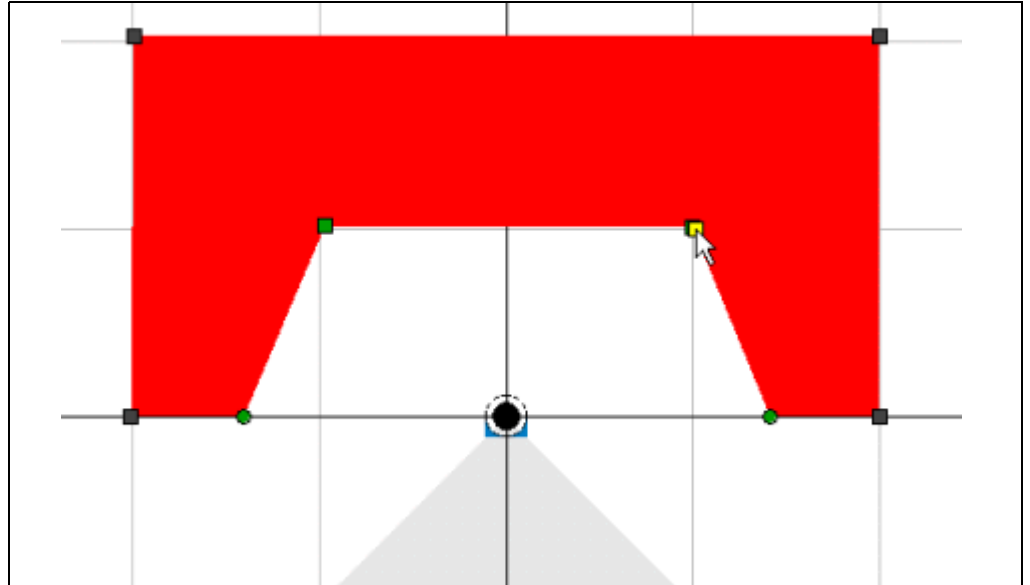

Fig. 13: Start points for a field

For information on how to set, move or delete start points, see [section 3.5.4 “Setting end points for a segmented field” on page 19](#).

When start points are set, the field editor may set points that are required for physical reasons in certain circumstances. You can move or delete these points like any others.

- The points that you have set using the mouse are shown as squares.
- The points that have been set automatically are shown as circles.

Important If you delete a start point, then the related end point will also be deleted in some circumstances.

3.5.6 Creating and editing a rectangular field

If, during the selection of the basic parameters you selected the RECTANGLE option (see [section 3.5.1 “Basic parameters for the field” on page 17](#)), then there is already a rectangular field in the field editor. You can move, increase and reduce in size, and rotate this field.

For a rectangular evaluation field you can define the following parameters:

- position
- angle of rotation
- width
- length

How to move a rectangular evaluation field:

Fig. 14: Moving a rectangular field



- On the toolbar click the symbol shown.
- Click the bottom right point of the field. The point changes to blue.
- Keep the left mouse button pressed and move the field. During the movement the field is shown in yellow. As soon as you release the left mouse button, the field is shown in red again.

How to increase or reduce the size of a rectangular evaluation field:

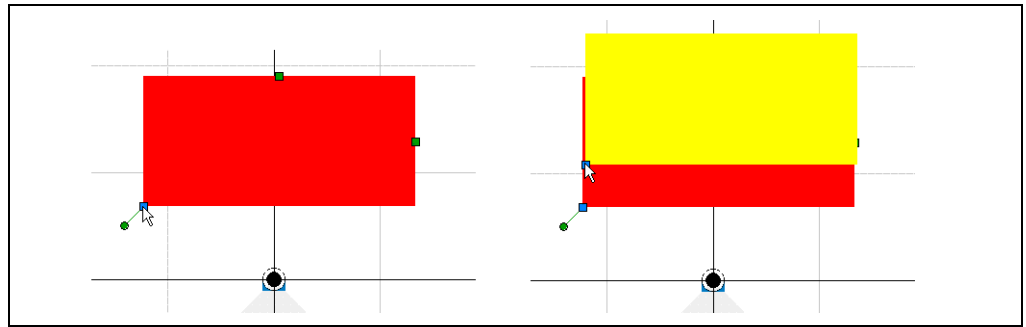
Fig. 15: Increasing or reducing the size of a rectangular field



- On the toolbar click the symbol shown.
- Click the top point or the right point for the field. The point changes to blue.
- Keep the left mouse button pressed and drag to increase or to reduce the size of the field. During the movement the field is shown in yellow. As soon as you release the left mouse button, the field is shown in red again.

How to rotate a rectangular evaluation field:

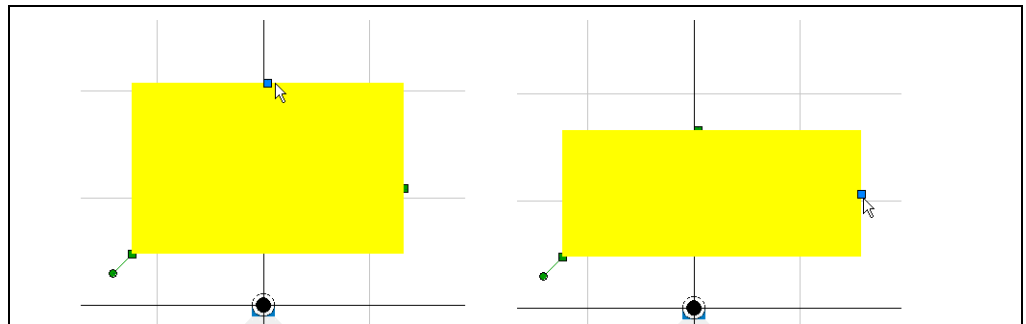
Fig. 16: Rotating a rectangular field



- On the toolbar click the symbol shown.
- Click the round point at the bottom left of the rectangular evaluation field. The point changes to blue.
- Keep the left mouse button pressed and rotate the field about the bottom left point. During the movement the field is shown in yellow. As soon as you release the left mouse button, the field is shown in red again.

How to change the evaluation field by making entries:

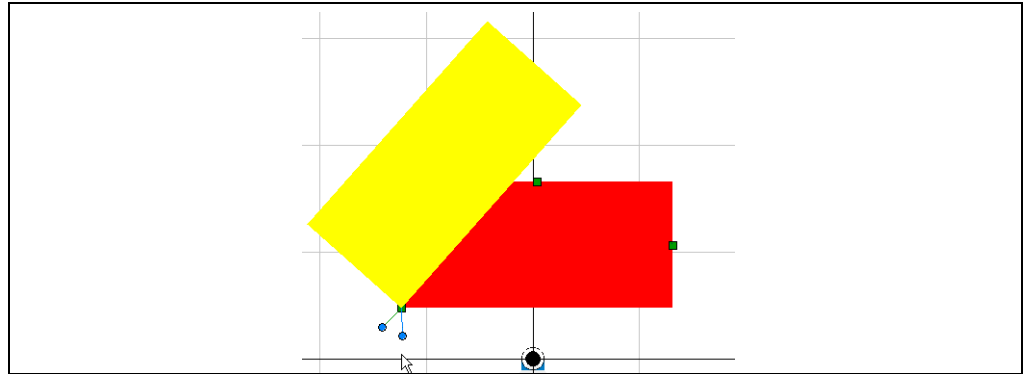
Fig. 17: Editing entries for rectangular evaluation field

- In the FIELD COORDINATES area click the EDIT button. You can now edit the fields in the FIELD COORDINATES area.
 - In the BASE POINT area, enter the X and Y coordinates for the bottom left point of the evaluation field.
 - Enter the angle of rotation in ° in the ROTATION field.
 - Enter the dimensions of the evaluation field in the WIDTH and LENGTH fields.
 - Click the PREVIEW button. The new evaluation field is displayed in yellow.
 - In the CHECK CHANGES dialog box, click the YES button. The changes are applied and the evaluation field is displayed in red.
- Or:
- In the CHECK CHANGES dialog box, click the NO button. The previous field is displayed again.

3.5.7 Creating and editing a dynamic field

If, during the selection of the basic parameters you selected the DYNAMIC option (see [section 3.5.1 "Basic parameters for the field" on page 17](#)), then there is already a dynamic field in the field editor. You can move this field and increase or reduce its size.

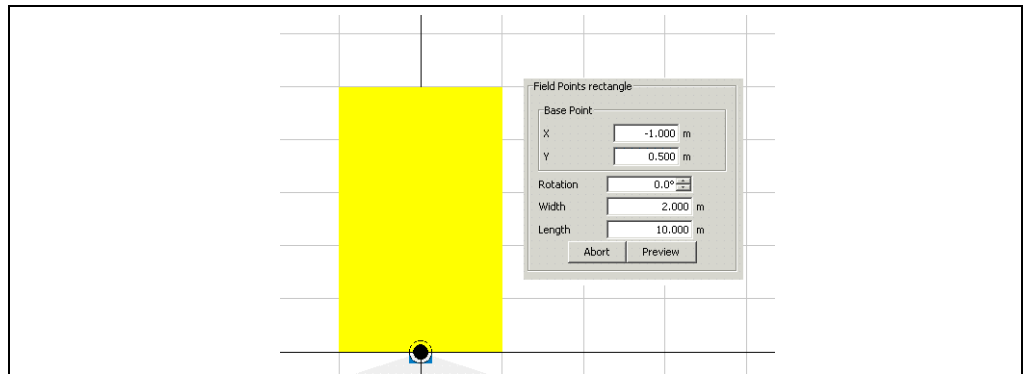
Important A dynamic field is always rectangular and cannot be rotated in the field editor. A dynamic evaluation field is displayed in the field editor with two areas. The area for the basic field (red, 1) and the area for the maximum physical size of the field (light red, 2).

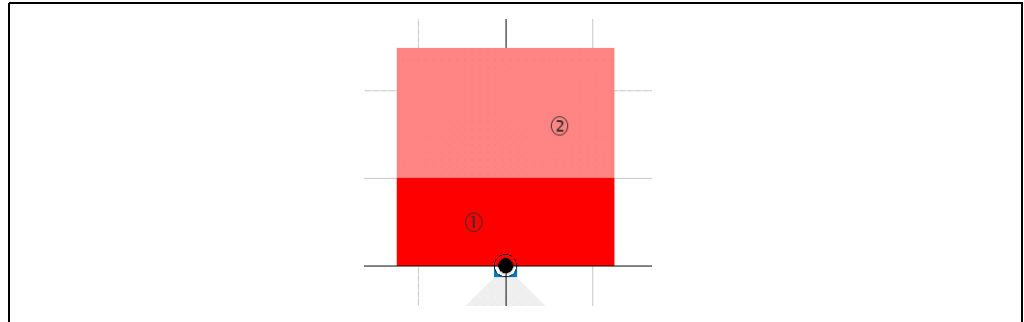

Fig. 18: View of a dynamic field in the field editor

The length of a dynamic field changes with the speed measured, e.g. using an encoder (see [section 3.4 "Increment source" on page 14](#)). When stationary ($V = 0$ m/s) the evaluation field is the same size as the basic field configured. The size increases continuously with increasing speed up to the largest physical size for the field at the maximum speed.

For a dynamic evaluation field you can define the following parameters:

- position
- width
- length at minimum speed
- length at maximum speed
- maximum speed in m/s

How to move a dynamic evaluation field:



- On the toolbar click the symbol shown.
- Click the bottom right point of the field. The point changes to blue.

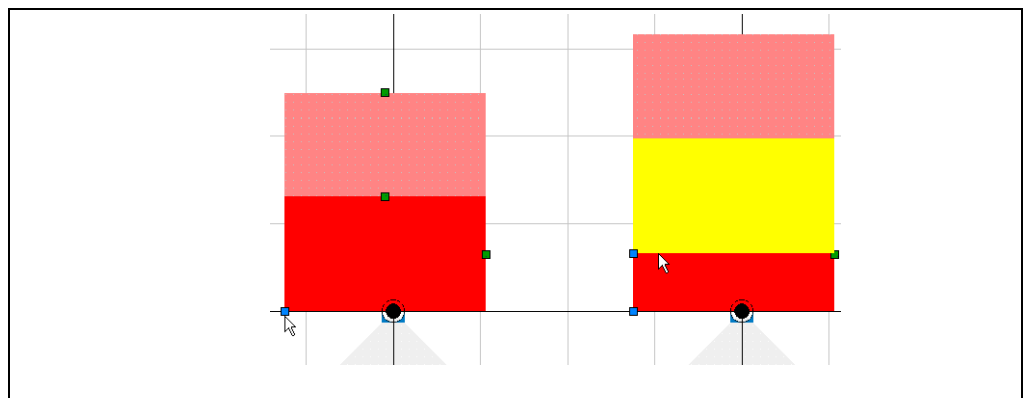

Fig. 19: Moving a dynamic field

- Keep the left mouse button pressed and move the field. During the movement the field is shown in yellow. As soon as you release the left mouse button, the field is shown in red again.

How to increase or decrease the basic field of a dynamic evaluation field:

- On the toolbar click the symbol shown.
- Click the top point or the right point for the basic field.
The point changes to blue.

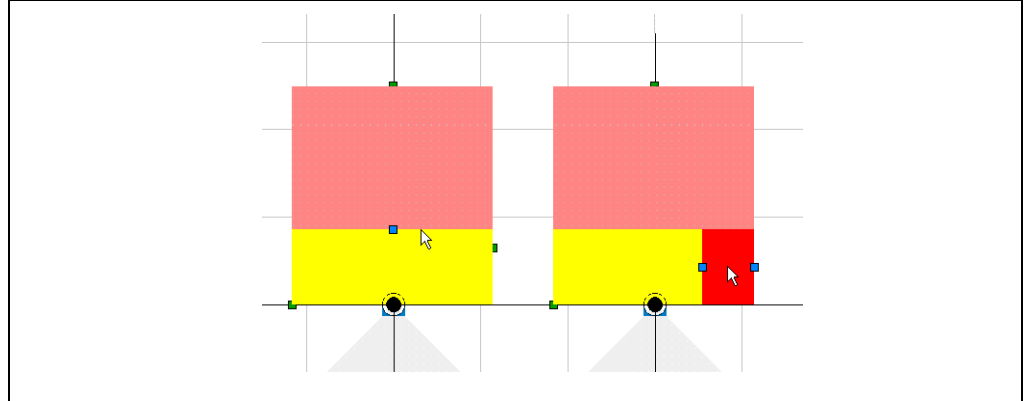

Fig. 20: Enlarging or reducing the basic field for a dynamic evaluation field

- Keep the left mouse button pressed and drag to increase or to reduce the size of the field.
During the movement the field is shown in yellow. As soon as you release the left mouse button, the field is shown in red again.

How to increase or decrease the maximum length of a dynamic evaluation field:

- On the toolbar click the symbol shown.
- Click the top point of the field.
The point changes to blue.

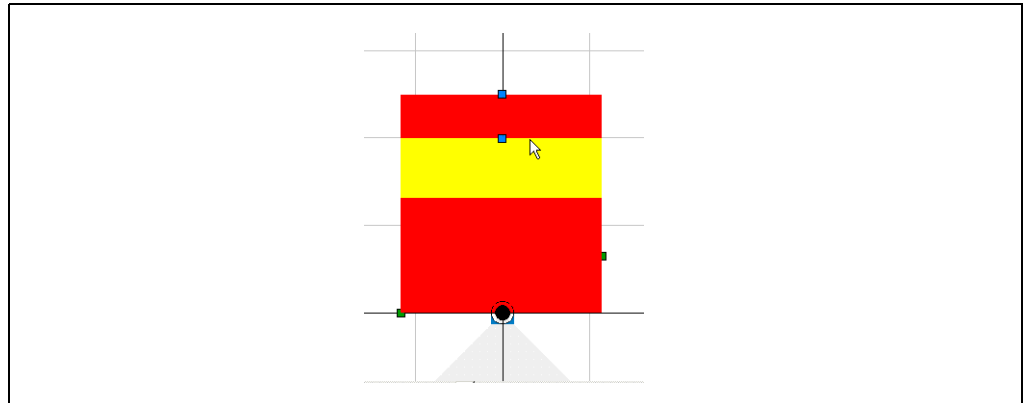

Fig. 21: Increasing or decreasing the maximum length of a dynamic evaluation field

- Keep the left mouse button pressed and drag to increase or to reduce the size of the field.
During the movement the field is shown in yellow. As soon as you release the left mouse button, the field is shown in red again.

How to change the evaluation field by making entries:

- In the FIELD COORDINATES area click the EDIT button.
You can now edit the fields in the FIELD COORDINATES area.

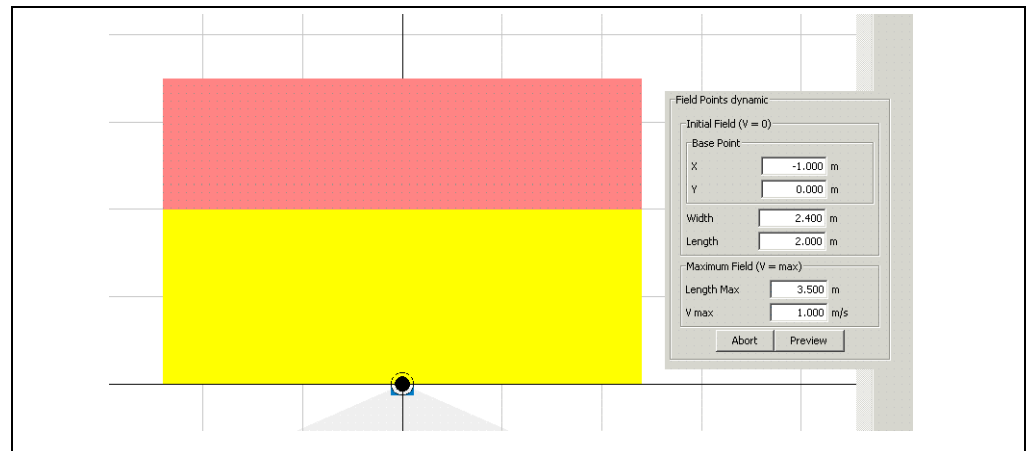

Fig. 22: Editing dynamic evaluation field entry

- In the BASE POINT area, enter the X and Y coordinates for the bottom left point of the evaluation field.
 - Enter the dimensions of the basic field in the WIDTH and LENGTH fields.
 - In the PHYSICAL SIZE (V = MAX) area, enter the MAXIMUM LENGTH and VMAX.
 - Click on the Preview button.
The new evaluation field is displayed in yellow.
 - In the CHECK CHANGES dialog box, click the YES button.
The changes are applied and the evaluation field is displayed in red.
- Or:
- In the CHECK CHANGES dialog box, click the No button.
The previous field is displayed again.

Important

- The X coordinate for the base point must be 0 or negative.
- The field width must be such that the field protrudes at least 0.001 mm (0.0000394 in) to the right of the centre of the LMS (X coordinate + width > 0 mm).
- The Y coordinate for the base point must never be negative.
- The maximum length must be greater than the length of the basic field.
If the length of the basic field exceeds the maximum physical size, then the maximum physical size is increased automatically by SOPAS ET.

3.5.8 Teaching-in an evaluation field

Important An evaluation field can only be taught-in if you have selected the SEGMENTED option in the basic parameters for the field.

The laser measurement system scans the visible room contour several times to teach-in an evaluation field. From the data obtained SOPAS ET determines the contour of the field.

Recommendation Show the scan line for the LMS in the field editor. You can then see the scanned contour and use it to orientate yourself.

You can define the start angle (1) and the end angle (2) used during teach-in and therefore pre-define the size of the field. The field you are creating is displayed in yellow.

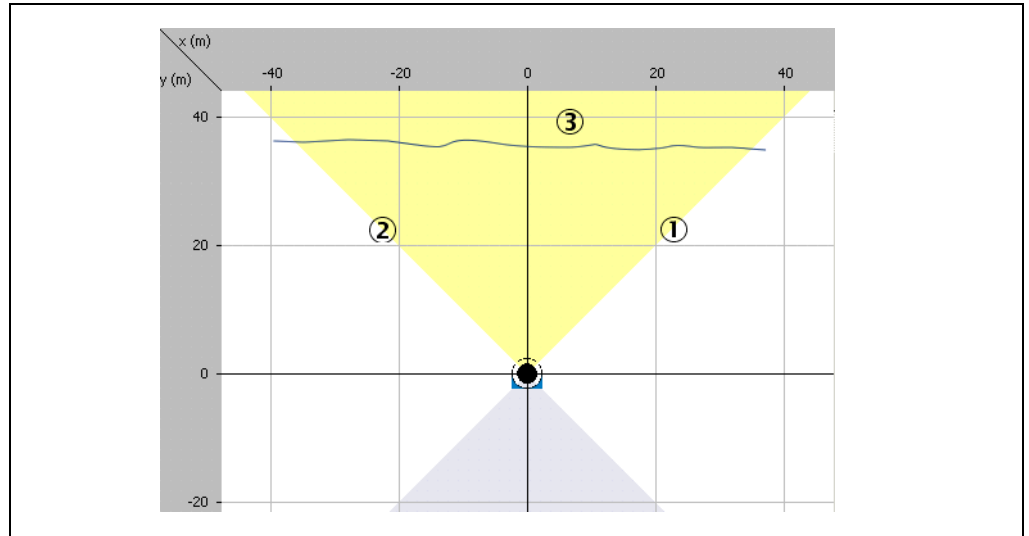

Fig. 23: Start angle and end angle for teaching-in an evaluation field

In addition you must define the distance to the scanned contour (3). The distance should be at least 100 mm (3.94 in), otherwise the evaluation field may be infringed in certain circumstances.

The distance results in positioning of each end point radially separated from the scanned contour by the distance. If a wall is scanned in front of the LMS, the evaluation field is taught-in with a curve.

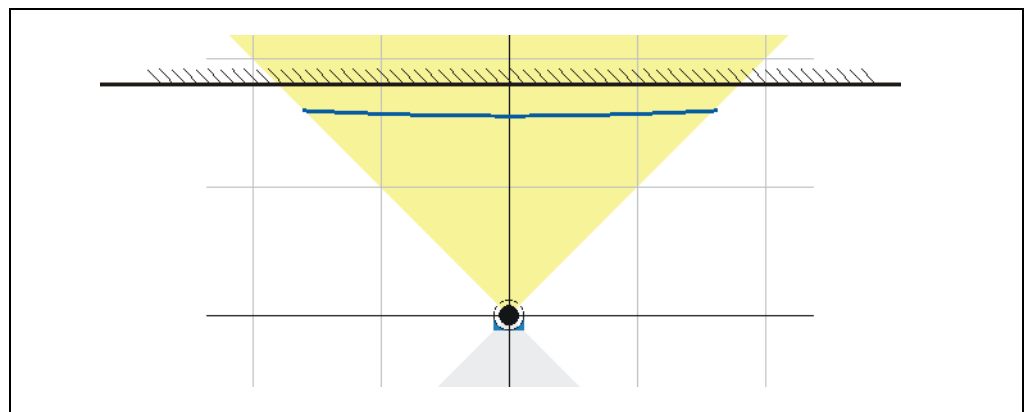

Fig. 24: Radial distance of an evaluation field to the scanned contour

How to teach-in an evaluation field:

- In the selection field on the top right in the field editor choose the TEACH-IN EVALUATION FIELD option.
The TEACH-IN EVALUATION FIELD dialog box is opened.
- Enter the values for the START ANGLE, END ANGLE and DISTANCE TO THE CONTOUR.
- Click the START button.
The contour will be scanned.
- Then, click the STOP button.
The evaluation field with its end points will be displayed.
Or:
- Walk along the field boundary required and during this process hold up a so-called target board (for example a piece of cardboard at least 10 × 10 cm) at the boundary required for the protective field.
SOPAS ET records the values for the objects scanned next. You can also define the size of the evaluation field by walking at a specific distance.
- Then, click the STOP button.
The evaluation field with its end points will be displayed.

Editing taught-in evaluation field

You can edit a taught-in evaluation field by moving or deleting the individual points for the field until the field has the required shape and size (see [section “How to move end points:” on page 21](#) and [section “How to delete end points:” on page 22](#)).

This action is however limited by the fact that an end point is set for each angular step on teaching-in a field.

- Important**
- Independent of the angular resolution configured, during teach-in points are taught-in at a spacing of 0.5°.
 - You can **only** add points manually to a taught-in field if the angular resolution configured is 0.25° (see [section 3.2.1 “Current configuration” on page 10](#)).
 - Points set manually are deleted by renewed teach-in.

Defining start points for a taught-in evaluation field

In the next step of the assistant you can teach-in the start points for an evaluation field.

Important If you do not want to teach-in any start points, then click EXIT in the assistant. The evaluation field then reaches right up to the LMS.

A start point must be set for each end point. For this reason the same values for the start and end angle are pre-defined as for teaching-in the end points.

The distance to the scanned contour must be larger (2) when teaching-in the start points than when teaching-in the end points (1).

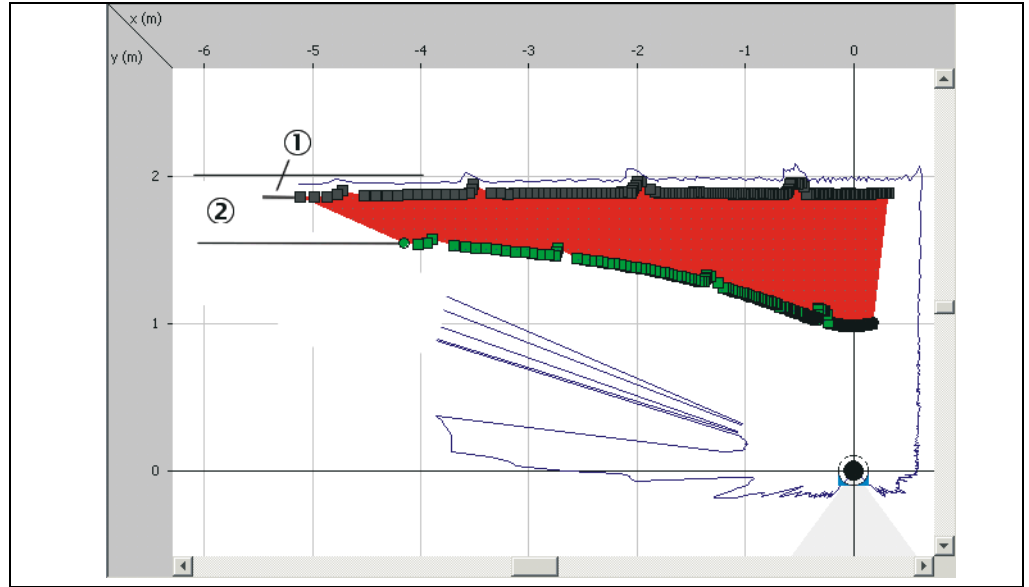

Fig. 25: Distance to the start points for a taught-in field

How to teach-in the start points of an evaluation field:

- In the selection field on the top right in the field editor choose the TEACH-IN EVALUATION FIELD option.
The TEACH-IN EVALUATION FIELD dialog box is opened.
- Enter the value for the DISTANCE TO THE CONTOUR.
The distance must be larger than when teaching-in the end points.
- Click the START button.
- Then, click the STOP button.
The evaluation field with its start points will be displayed.

3.5.9 Defining the contour as a reference

With the contour as reference function an evaluation field is placed around the scanned contour of an object.

The actual function is activated by the strategy for the evaluation case. Evaluation case and evaluation field must therefore match (see [section 3.6.4 "Evaluation strategy" on page 38](#)).

For the evaluation of the field, the contour of an object (e.g. a house wall) must always be present inside the field, i.e. an object must always be present (the scanned contour is used as a reference).

You can either teach-in or set manually an evaluation field for the contour as reference.

Teaching-in evaluation field for contour as reference

Important An evaluation field can only be taught-in for the contour as reference function if you have selected the SEGMENTED option in the basic parameters for the field.

Recommendation Show the scan line for the LMS in the field editor. You can then see the scanned contour and use it to orientate yourself.

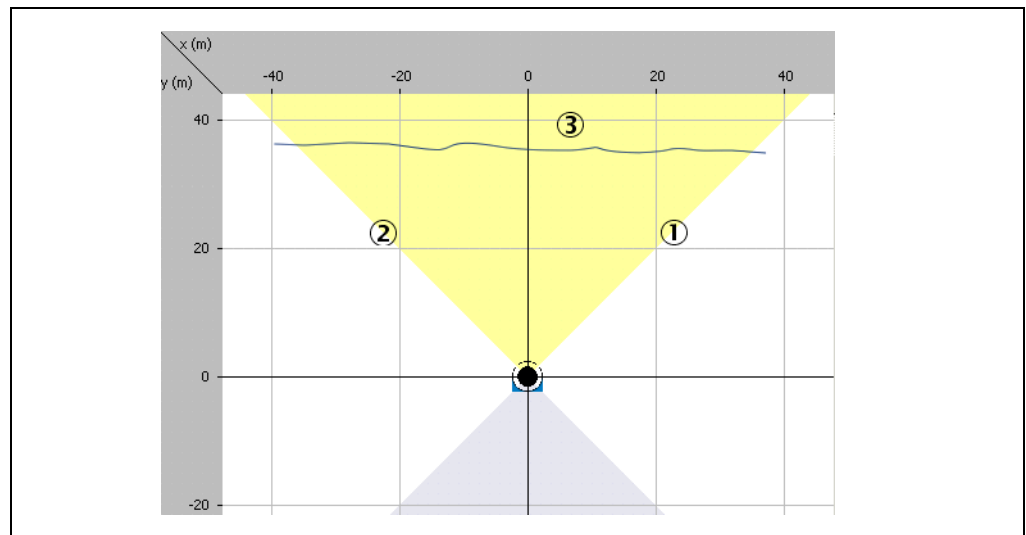

Fig. 26: Start angle and end angle during teach-in

You can define the start angle (1) and the end angle (2) used during teach-in and therefore pre-define the size of the field. The field you are creating is displayed in yellow.

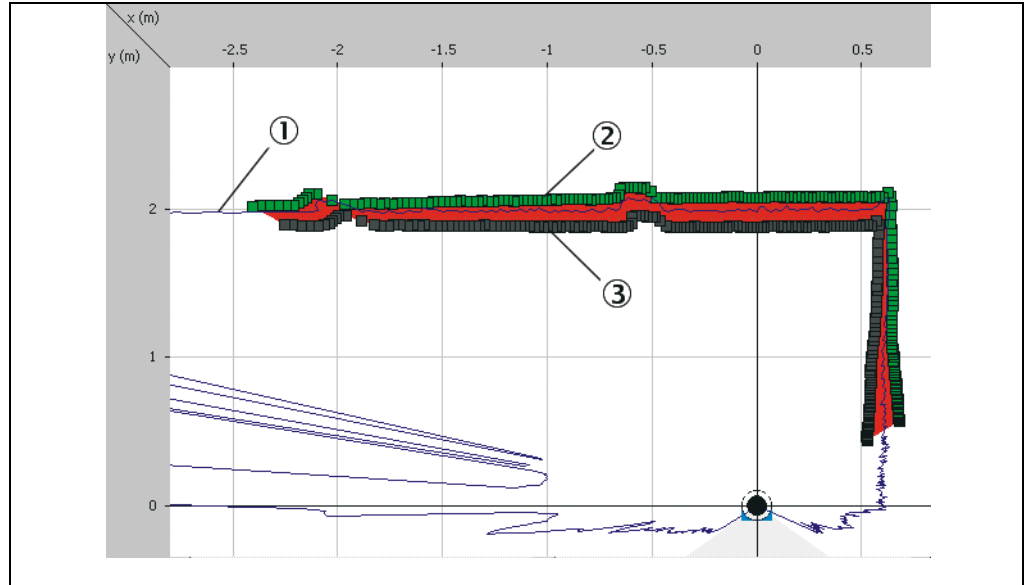

Fig. 27: Distance to the start points for a taught-in field

For the contour you must define the positive (2) and the negative (3) distance in relation to the scanned contour (1). The distance should be at least 100 mm (3.94 in), otherwise the contour will be continuously infringed.

How to teach-in an evaluation field for the contour as reference function:

- In the selection field on the top right in the field editor choose the TEACH-IN CONTOUR option.
The TEACH-IN CONTOUR dialog box is opened.
- Enter the values for START ANGLE and END ANGLE as well as for the POSITIVE DISTANCE and the NEGATIVE DISTANCE.
- Click the START button.
The contour will be scanned.
- Then, click the STOP button.
The evaluation field with its end points and start points is placed around the contour and displayed.

Manually editing evaluation field for contour as reference

Recommendation Show the scan line for the LMS in the field editor. You can then see the scanned contour and use it to orientate yourself.

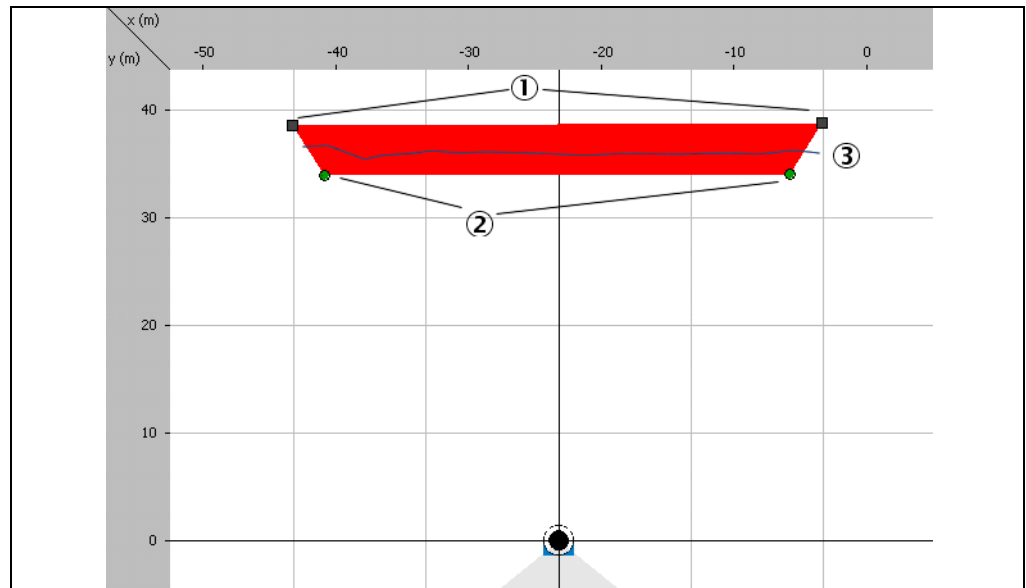

Fig. 28: Distance to the start points for a manually edited field

With end points (1) and start points (2) you can define the size of the field that you want to place around the contour of the object (3).

How to manually edit an evaluation field for the contour as reference:

- In the selection field on the top right in the field editor choose the **MANUAL** option.
- Set the end points of the evaluation field (see [“Setting end points for a segmented field” on page 19](#)).
- Set the start points of the evaluation field (see [section 3.5.5 “Setting start points for a field” on page 23](#)).
- Ensure the positive and negative distance to the scanned contour for the field is sufficient ($> 100 \text{ mm}$ (3.94 in)).

3.5.10 Teach-in tamper protection

Important The tamper protection function is already pre-defined on the LMS122/123 as the 10th evaluation field. If the function is used for the fields 1 to 9, then the LMS will switch the alarm output continuously. If you want to use other fields also for tamper protection, then you must change the pre-defined evaluation cases using the Expert mode.

With the tamper protection function an evaluation field is placed around the scanned contour. During the evaluation of the field, the contour of an object (e.g. the floor) must always be within the field.

If the LMS122/123 is moved or rotated (tampered with), the distance from the contour to the LMS increases and the LMS switches its alarm output. If, on the other hand, a person enters the field, although the contour can no longer be seen, the tamper protection function does not evaluate this situation as a contour infringement.

Recommendation Show the scan line for the LMS in the field editor (3). You can then see the scanned contour and use it to orientate yourself.

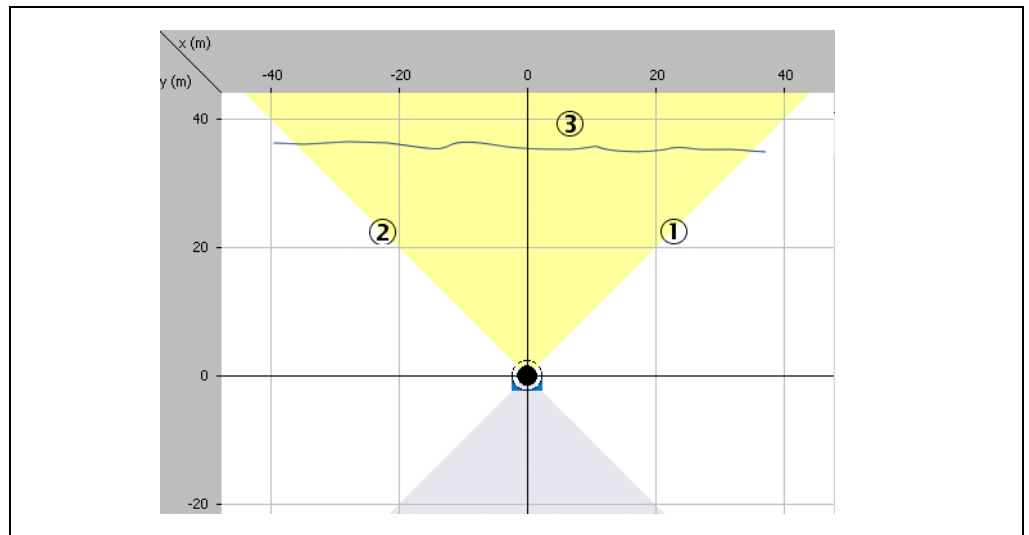

Fig. 29: Start angle and end angle during teach-in

You can define the start angle (1) and the end angle (2) used during teach-in and therefore pre-define the size of the field. The field you are creating is displayed in yellow.

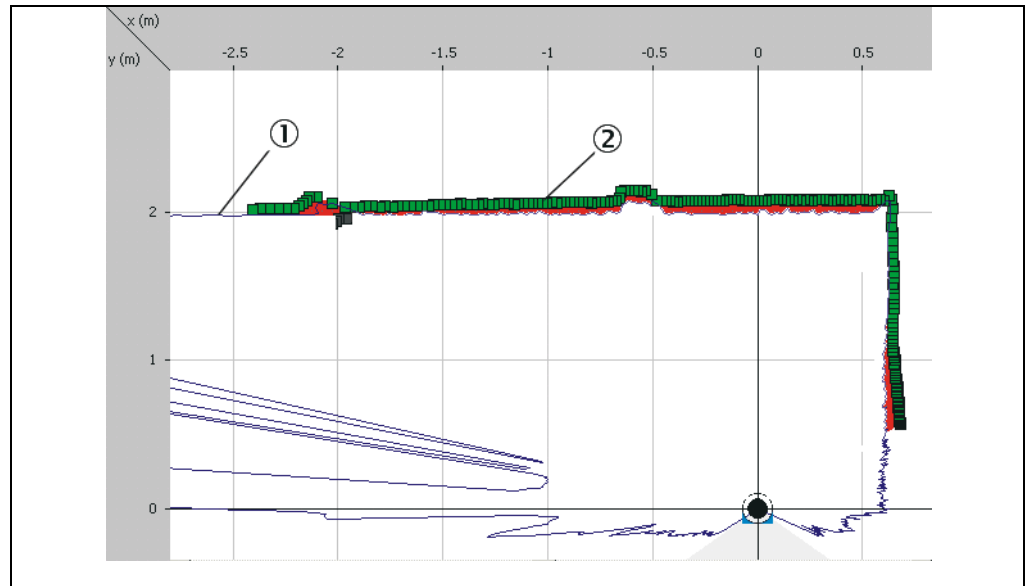

Fig. 30: Distance to the start points for a taught-in field



For the contour you must define the distance (2) in relation to the scanned contour (1). The distance should be at least 100 mm (3.94 in), otherwise the contour will be continuously infringed.

How to teach-in an evaluation field for the tamper protection function:

- In the selection field on the top right in the field editor choose the TAMPER PROTECTION option.
The TEACH-IN TAMPER PROTECTION dialog box is opened.
- Enter the values for the START ANGLE and END ANGLE as well as for the DISTANCE TO THE CONTOUR.
- Click the START button.
The contour will be scanned.
- Then, click the STOP button.
The evaluation field with its start points and end points is placed around the contour and displayed.

3.6 Evaluation cases

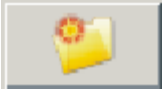
The existing evaluation cases are displayed in a table in the EVALUATION CASES OVERVIEW area. You can run the following functions using the buttons above the table:

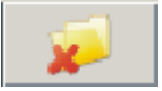
Symbol	Meaning	Comment
	Create evaluation case	You can create a new evaluation case using this button. The CREATE EVALUATION CASE dialog box is opened (see 3.6.1 on page 37).
	Edit evaluation case	You can edit an existing evaluation case using this button. ➤ For this purpose mark one of the evaluation cases in the table and then click the button.
	Copy evaluation case	You can copy an existing evaluation case using this button. During this process, all parameters for the existing evaluation case are copied to the new evaluation case. ➤ For this purpose mark one of the evaluation cases in the table and then click the button.
	Delete evaluation case	You can delete an existing evaluation case using this button. ➤ For this purpose mark one of the evaluation cases in the table and then click the button.

Tab. 5: Buttons for managing the evaluation cases

How to configure the evaluation cases of the LMS:



- In the PROJECT TREE, LMS..., PARAMETER, open the device page EVALUATION CASES. In the EVALUATION CASES OVERVIEW area you can create, copy, edit or delete evaluation cases.

3.6.1 Name of the evaluation case

In SOPAS ET each evaluation case is given a name as well as its number.

- In the BASIC PARAMETERS area enter a name for the evaluation case in the NAME field.
- Use meaningful names that describe the evaluation case (such as forward movement, slow movement, day configuration, night configuration, etc.).

3.6.2 Inputs

If the evaluation case is not to be permanently active, then choose an input combination to activate the evaluation case. You can configure whether the input must be active low or active high to activate the evaluation case.

You can also configure a combination of two input states to activate the evaluation case. As a result up to four combinations for activating different evaluations cases are possible.

Input 1	Input 2	Evaluation case
Active high	Active high	Evaluation case 1
Active high	Active low	Evaluation case 2
Active low	Active high	Evaluation case 3
Active low	Active low	Evaluation case 4

Tab. 6: Input combination examples

- Important**
- An input combination can also be defined for several evaluation cases, e.g. two evaluation cases will then be active simultaneously.
 - If you choose NOT RELEVANT for both inputs, the evaluation case is always active.
 - Choose whether and which input is to have the state active high or active low to activate the evaluation case.

3.6.3 Evaluation area

For each evaluation case, you can define which field is to be used. You can only select fields for an evaluation case if you have first created at least one field (see [section 3.5 “Evaluation fields” on page 16](#)).

- Important** If you have previously selected the contour evaluation strategy, then only segmented fields are available (rectangular and dynamic fields are hidden).
- In the FIELD NAME selection field choose the required evaluation field.
The number of the evaluation field is displayed in the NUMBER field.

3.6.4 Evaluation strategy

The evaluation strategy defines how the evaluation field is evaluated.

- Important** The different strategies will produce different results. For this reason the evaluation strategy must exactly match the type of evaluation case.

Pixel evaluation

The LMS evaluates the entire area of the field. If an object enters the field, this result is sent to the related output.

For the LMS to detect an object, the object must be detected in one place for at least the duration of the RESPONSE TIME. The response time means that the presence of objects in the evaluation field will not immediately trigger the evaluation case. Objects must therefore be scanned several times if a response time is configured (for a scanning frequency of 25 Hz and a response time of 1,000 ms for example 25 times).

The DISTANCE-DEPENDENT option means that an object that moves radially towards or away from the LMS is also evaluated as an object.

The value in the OBJECT SEPARATION field defines the depth within which two detections are interpreted as one object.

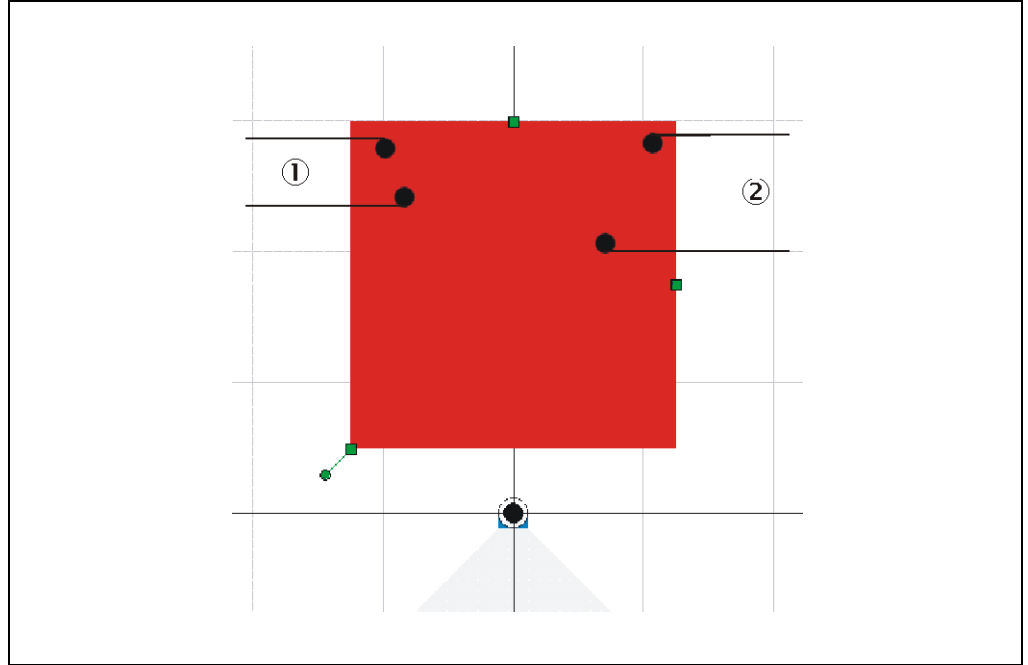

Fig. 31: Distance-dependent pixel evaluation

In **Fig. 31** the detections in example (1) are so close together (distance \leq value in the OBJECT SEPARATION field) that they are considered as one object. The evaluation field is considered infringed.

In example (2) the detections are far enough apart (distance $>$ value in the OBJECT SEPARATION field) that they are considered as two separate objects. The evaluation field is not considered infringed.

Blanking

The LMS evaluates the entire area of the field. However, using blanking objects of a specific size can be blanked. An object is only detected if it is larger than the blanking size configured.

For the LMS to detect an object, the object must be detected in one place for at least the duration of the RESPONSE TIME. The response time means that the presence of objects in the evaluation field will not immediately trigger the evaluation case. Objects must therefore be scanned several times if a response time is configured (for a scanning frequency of 25 Hz and a response time of 1,000 ms for example 25 times).

With the DISTANCE-DEPENDENT option, overlapping objects within a certain distance are regarded as one object.

The value in the OBJECT SEPARATION field defines the depth within which the two objects are combined.

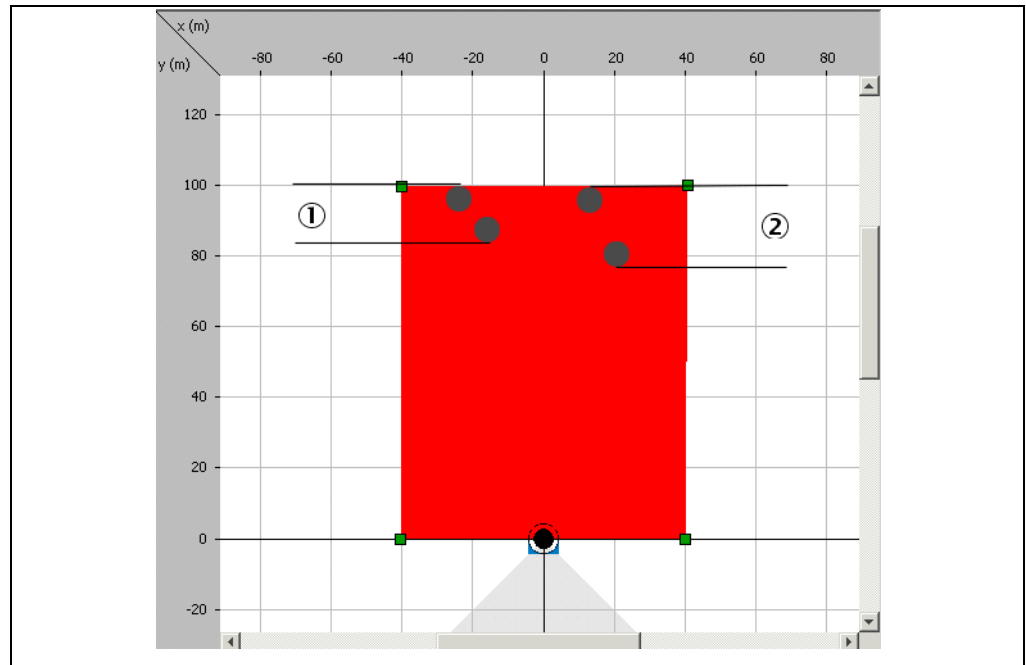

Fig. 32: Distance-dependent evaluation of two objects

In [Fig. 32](#) the objects in example (1) are so close together (distance \leq value in the OBJECT SEPARATION field) that they are considered as one object. As a result the objects are not blanked and the evaluation field is considered infringed.

In example (2) the objects are far enough apart (distance $>$ value in the OBJECT SEPARATION field) that they are considered as two separate objects. As a result the objects are blanked and the evaluation field is considered to not be infringed.

Contour monitoring with blanking

The LMS evaluates the presence of a contour that must always be in the evaluation field (see [section 3.5.9 "Defining the contour as a reference" on page 32](#)). As a result the LMS can detect, e.g., that a door is opening or that the position of the LMS is being changed. Also the crawling beneath a vertical evaluation field or the deflection of the laser beam by a mirror can be detected.

Using blanking the lack of part of a contour can be blanked up to a certain size.

For the LMS to detect a contour infringement, the infringement must be detected in one place for at least the duration of the RESPONSE TIME. The response time means that contour infringements will not immediately trigger the evaluation case. Contour infringements must therefore be scanned several times if a response time is configured (for a scanning frequency of 25 Hz and a response time of 1.000 ms for example 25 times).

I/O operator

Using the I/O operator evaluation strategy you can link the inputs on the LMS with its outputs. The result of this operator depends on ...

- whether the inputs are configured as active high or active low (see [section 3.6.2 "Inputs" on page 37](#)).
- which output the result of the evaluation acts upon and whether it is inverted (see [section 3.6.5 "Evaluation result" on page 41](#)).
- whether the output is switched by the field application (see [section 3.8.9 "Digital outputs" on page 46](#)).
- how the results of the monitoring cases are linked at the output (see [section 3.8.10 "Digital outputs of the application" on page 46](#)).

Manipulation prevention

If pixel evaluation is configured, glare may result in it no longer being possible for the LMS to monitor a field. If blanking is configured, small objects in the near range of the LMS can cause large shadows.

To prevent this situation arising, you can configure the TAMPER PROTECTION option. This feature switches the evaluation field if ...

- an object that is smaller than or equal to the blanked object size is in front of the laser output aperture on the LMS for the configured EXPANDED RESPONSE TIME.
- if the LMS is dazzled for longer than the EXPANDED RESPONSE TIME configured.

3.6.5 Evaluation result

The used evaluation field and the evaluation strategy for the evaluation case produce an evaluation result as soon as the field is infringed or the contour is interrupted.

- Choose the physical output on which the result of the evaluation case is to act.
- Also choose whether the evaluation result is to be inverted.
- If necessary, enter a response time for the output.

Important Take into account this response time if you use a downstream system, e.g. for stopping a vehicle or plant. You must then, e.g., increase the stopping distance accordingly.

3.7 Data processing

In the OUTPUT FORMAT area you can configure which data are to be output in which format when the measured data are requested.

The measured data message contains two channels for the output of distance values and, if necessary, remission values.

The values for the first pulse received are transferred in channel 1, and the values for a 2nd pulse, if received, in channel 2. You can decide whether one of the channels or both of the channels are to be transferred.

Important If only one pulse is received, its values are always transferred in channel 1. If only channel 2 is activated, the measured value will be lost in such a case.

You can also configure whether remission values are to be transferred in addition to the distance values. For the remission values you can also decide whether the transfer is with a resolution of 8 bits (0 to 255) or 16 bits (0 to 65,535).

In addition you can configure whether data from an incremental encoder connected, the device name configured for the LMS and a time stamp for the scan are output in the measured data message.

How to configure the data processing:



- In the PROJECT TREE, LMS..., PARAMETER, open the device page DATA PROCESSING.
- In the OUTPUT FORMAT area choose the necessary parameters.

3.8 Network/interfaces/inputs and outputs

3.8.1 Network options

You must assign a device ID for the LMS. By default this ID is used as the CAN device number for the CAN bus (see [3.8.7 on page 45](#)).

Important You must assign a unique device number from 1 to 127 for each device on the CAN bus. In addition you can assign a device name. For example, use the device name to be able to identify the LMS more easily in a project with several devices.

How to configure the network options:



- In the PROJECT TREE, LMS..., PARAMETER, open the device page NETWORK/INTERFACES/IOs.
- In the NETWORK OPTIONS area, fill in the fields DEVICE ID and DEVICE NAME.

3.8.2 Monitoring

The LMS can monitor other devices over its interfaces. For this purpose a heartbeat message must be sent by these devices.

Choose the interface over which the other devices are to be monitored.

Enter the IDs for the devices to be monitored. Separate the IDs for several devices using commas (1,34,102).

Enter a maximum power up time for the monitored devices. This setting will result in the LMS only expecting the heartbeat message after this power time has elapsed. As a result there will not be any error messages during the power up time for the devices monitored.

How to configure the monitoring of the LMS:



- In the PROJECT TREE, LMS..., PARAMETER, open the device page NETWORK/INTERFACES/IOs.
- In the MONITORING area enter the necessary parameters.

3.8.3 Serial host interface

The serial host interface is an RS-232 interface. The host interface permits the configuration of the LMS and only limited measured value output.

The factory setting for the host interface is as follows:

- 57,600 Baud
- 8 data bits
- 1 stop bit
- no parity

Important If you change the parameters for the host interface over the host interface, the connection to the device will be lost. You must then scan for the LMS again in SOPAS ET.

Heartbeat message

The heartbeat message enables the connected application to cyclically check the device status even if it is idle. The message is always output if it is not possible to measure an object.

- Activate the ENABLE HEARTBEAT MESSAGE option so that the LMS generates the related message.
- In the HEARTBEAT INTERVAL field enter the duration of the interval in seconds.
 - If the RESTART THE INTERVAL ON SENDING option is activated, the interval is restarted immediately after sending. The time between two messages is exactly the duration of the interval in seconds.
 - If the RESTART THE INTERVAL ON SENDING option is inactive, the interval is only restarted after the message has been sent successfully. The time between two messages is therefore longer than the duration of the interval in seconds.

How to configure the serial host interface:



- In the PROJECT TREE, LMS..., PARAMETER, NETWORK/INTERFACES/IOs, open the device page SERIAL.
- Make the necessary settings for the configuration in the SERIAL HOST INTERFACE area.

3.8.4 Serial auxiliary interface

The serial auxiliary interface is an RS-232 interface. The auxiliary interface permits the configuration of the LMS.

The factory setting for the host interface is as follows:

- 57,600 Baud
- 8 data bits
- 1 stop bit
- no parity

Important If you change the parameters for the auxiliary interface over the auxiliary interface, the connection to the device will be lost. You must then scan for the LMS again in SOPAS ET.

Heartbeat message

The heartbeat message enables the connected application to cyclically check the device status even if it is idle. The message is always output if it is not possible to measure an object.

- Activate the ENABLE HEARTBEAT MESSAGE option so that the LMS generates the related message.
- In the HEARTBEAT INTERVAL field enter the duration of the interval in seconds.
 - If the RESTART THE INTERVAL ON SENDING option is activated, the interval is restarted immediately after sending. The time between two messages is exactly the duration of the interval in seconds.
 - If the RESTART THE INTERVAL ON SENDING option is inactive, the interval is only restarted after the message has been sent successfully. The time between two messages is therefore longer than the duration of the interval in seconds.

How to configure the serial auxiliary interface:



- In the PROJECT TREE, LMS..., PARAMETER, NETWORK/INTERFACES/IOs, open the device page SERIAL.
- Make the necessary settings for the configuration in the SERIAL AUXILIARY INTERFACE area.

3.8.5 General parameters for the Ethernet interface

The Ethernet interface has a data transmission rate of 10/100 MBit. The interface is a TCP/IP interface. Full duplex and half duplex are supported.

The RS-Ethernet interface allows the configuration of the LMS as well as the output of measured values.

Important If you change the parameters for the Ethernet interface, to apply the parameters you must first save the data in the LMS in non-volatile memory and then restart the LMS. The RESTART button is available for this action. If your PC/notebook is connected to the LMS using the Ethernet interface, the connection to the device will be lost. You must then scan for the LMS again in SOPAS ET.

How to configure the Ethernet interface:



- In the PROJECT TREE, LMS..., PARAMETER, NETWORK/INTERFACES/IOs, open the device page ETHERNET.
- In the ETHERNET area enter the necessary parameters for the operation of the Ethernet interface.

3.8.6 Parameters for the host port and the aux ports for the Ethernet interface

The Ethernet interface has two ports, the host port and the aux port. You can configure the LMS and communicate with the LMS using messages over both ports.

As a result you can setup the interface as follows:

- The configuration and the message communication are realised using a common port.
- The configuration is realised using one port, the message communication via the other port.

Heartbeat message

The heartbeat message enables the connected application to cyclically check the device status even if it is idle. The message is always output if it is not possible to measure an object.

- Activate the ENABLE HEARTBEAT MESSAGE option so that the LMS generates the related message.
- In the HEARTBEAT INTERVAL field enter the duration of the interval in seconds.
 - If the RESTART THE INTERVAL ON SENDING option is activated, the interval is restarted immediately after sending. The time between two messages is exactly the duration of the interval in seconds.
 - If the RESTART THE INTERVAL ON SENDING option is inactive, the interval is only restarted after the message has been sent successfully. The time between two messages is therefore longer than the duration of the interval in seconds.

3.8.7 CAN bus

Important The LMS supports the CAN standard 2.0A.

For data communication using CAN (Controller Area Network) you must ...

- set the correct operating mode for the CAN bus on the LMS.
 - SICK network (for communication with SICK devices via CAN)
 - CANopen (for communication with devices supporting the CANopen standard)
- set identical baud rate parameters on all devices on the bus.

In addition you must define a device ID between 1 and 127 that is unique on the CAN bus. The device ID for the LMS is entered by default (see [section 3.8.1 “Network options” on page 42](#)).

Deactivate the USE DEVICE ID AS CAN ID option. Then a CAN ID that is different to the device ID can be entered in the CAN ID field.

How to configure the CAN interface:



- In the PROJECT TREE, LMS..., PARAMETER, NETWORK/INTERFACES/IOs, open the device page CAN.
- In the CAN area in the MODE and BAUD RATE fields enter the valid values for the CAN bus.

3.8.8 Digital inputs

In CONTROL field choose whether you want to set the de-bounce as a function of time or track.

- In case of time-dependent control, enter the debounce in ms.
- In case of track-dependent control, enter the debounce in mm.

Important For track-dependent control an encoder must be connected and configured. The LMS can then calculate a distance based on the encoder pulses (e.g. for a vehicle). The de-bounce can be defined as a function of a distance, speed fluctuations have no effect.

Logic

For switches or sensors connected to the inputs, choose whether these are to be active high or active low.

Debounce

To bridge bounce times on external switches, you can configure a debounce for the inputs.

- In the DEBOUNCE input field enter the time in ms that is necessary to debounce the switches or sensors connected.

Or

- In the DEBOUNCE input field enter the track in mm that is necessary to debounce the switches or sensors connected.

3.8.9 Digital outputs

For the output 1 to output 3 outputs on the LMS, first choose the function that the output is to perform.

- no function
- application
The output is available for the field application. Infringements of the evaluation fields or contour infringements are signalled by the output.
- Device Ready
The output is used to signal the status “Device Ready”.
The output is maintained for at least 200 ms.
- SOPAS command
The output is controlled using messages from a host (see [chapter “Annex” in the operating instructions](#) for the LMS).

For the outputs you can select whether they are to switch active high or active low.

How to configure the function of the outputs:



- In the PROJECT TREE, LMS..., PARAMETER, NETWORK/INTERFACES/IOs, open the device page DIGITAL OUTPUTS.
In the OUTPUT 1...3 areas you can undertake the necessary configuration steps for the outputs.

3.8.10 Digital outputs of the application

If several monitoring cases act on an output, you must define how the results of the monitoring cases are linked. The related results can be linked using an AND or an OR operator.

Explanation The LOGIC selection field is only active if you have configured at least two evaluation cases that act on the output (see [section 3.6.1 “Name of the evaluation case” on page 37](#)).

By default the related output is reset immediately.

However, you can configure a delay (e.g. to activate a horn or to forward the signal to a PLC) or reset the output using an input.

- In the RESET field select the option TIME. Configure in the RETENTION TIME field a time in ms for which the output remains in this active output state. Adjust the retention time to the input electronics on the downstream system.
- Or
- In the RESET field select the option INPUT. In the NUMBER field choose the number of the input that is to reset the output. In the SENSITIVITY field choose what the input is to react to.



How to configure the function of the outputs:

- In the PROJECT TREE, LMS..., PARAMETER, NETWORK/INTERFACES/IOs, open the device page DIGITAL OUTPUTS.

In the OUTPUT 1...3 APPLICATION areas you can undertake the necessary configuration steps for the outputs.

3.8.11 External switching outputs

A CAN module can be supplied to expand the switching outputs. With this module additional external switching outputs are made available.

The external switching outputs have the same functionality as the digital switching outputs on the LMS (see [section 3.8.9 “Digital outputs” on page 46](#) and [section 3.8.10 “Digital outputs of the application” on page 46](#)).

You can define whether the module is active. If you activate the module, the external outputs 1 to n are available for the evaluation cases.

You can also define which ID the module has on the CAN bus. For information on the ID and configuration of the module, see the operating instructions for the CAN module.

If you activate the MONITORING option, the external CAN module will be monitored via CAN bus. Only if the CAN module is functioning error-free, the LMS will change to the “Device Ready” status.

How to configure the function of the outputs:



- In the PROJECT TREE, LMS..., PARAMETER, NETWORK/INTERFACES/IOs, open the device page EXTERNAL DIGITAL OUTPUTS.

- Select the option ACTIVE.

The EXTERNAL OUTPUT 1...N APPLICATION areas are displayed. You can undertake the necessary configuration steps for the outputs in these areas.

Important If you deactivate the CAN module in SOPAS and have used the external switching outputs for evaluation cases (see [section 3.6.5 “Evaluation result” on page 41](#)), these evaluation cases will be invalid.

3.8.12 Display

In SOPAS ET you can define which functions the LEDs and the 7-segment display are to have.

LED Q1 and Q2

- no function
The two LEDs never illuminate.
- application
The two LEDs are controlled by the field application.
 - Q1 illuminates if an evaluation field is infringed or a reference contour is interrupted.
 - Q2 never illuminates.
- SOPAS command
The LEDs are controlled by a SOPAS ET message (see [chapter “Annex” in the operating instructions](#) for the LMS).

LED OK and Stop

- application
The two LEDs are controlled by the field application.
 - OK illuminates if no evaluation field is infringed and no reference contour is interrupted.
 - Stop illuminates if an evaluation field is infringed or a reference contour is interrupted.
- SOPAS command
The LEDs are controlled by a SOPAS ET message (see [chapter “Annex” in the operating instructions](#) for the LMS).

7-segment display

- no function
The 7-segment display never indicates anything.
- application
The 7-segment display is controlled by the field application and indicates the status and error messages from the LMS (see [section “Troubleshooting” in the operating instructions](#) for the LMS).
- SOPAS command
The 7-segment display is controlled by a SOPAS ET message (see [chapter “Annex” in the operating instructions](#) for the LMS).



- In the PROJECT TREE, LMS..., PARAMETER, NETWORK/INTERFACES/IOs, open the device page DISPLAY.

In the DISPLAY area you can undertake the necessary configuration steps for the LEDs and the 7-segment display.

4 Monitor

4.1 Field evaluation monitor

In the field evaluation monitor you can use the same tools to configure the view as in the field editor (see [section 3.5.3 “Adapting the field editor view” on page 18](#)).

Using the field evaluation monitor, you can analyse whether and how evaluation fields are infringed and how the outputs on the LMS behave.

Important The indication of events, such as field or contour infringements, appears on the monitor with a slight delay.

- In the top right selection field, choose whether you want to monitor the outputs or the evaluation cases.

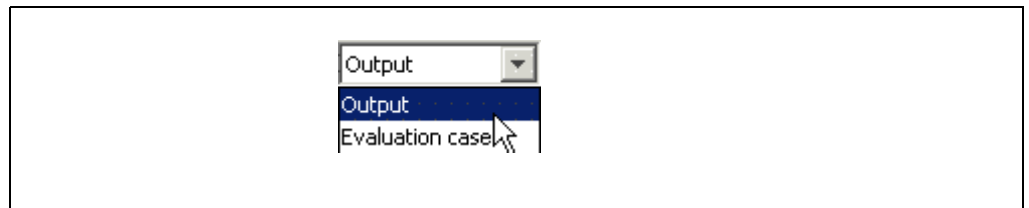

Fig. 33: Selection of the indication on the monitor

Display of the evaluation cases

- In the EVALUATION CASE area, choose the evaluation case to be monitored.
 - Under the name of the evaluation case, the configured strategy, the field allocated and the status of the field are displayed in different colours.
 - Green: The evaluation field for the evaluation case has not been infringed.
 - Yellow: The evaluation field for the evaluation case has been infringed.
 - Grey: The evaluation case is invalid, for instance because the evaluation field allocated has been deleted.

The evaluation field allocated to the evaluation case is displayed in the actual Diagnostics window.

In the OUTPUTS area the states and the number of switching actions since switching on are displayed for outputs 1 to 3.

The 7-segment display for the LMS is displayed in the DEVICE STATUS area.

Display of the outputs

- In the OUTPUT area, choose the switching output to be monitored.
 - Under the name of the output, the name and number of the evaluation cases on which the output acts are displayed.
 - The evaluation fields allocated to the output are displayed in different colours in the actual Diagnostics window.
 - Green: The evaluation field has not been infringed.
 - Yellow: The evaluation field has been infringed.

In the OUTPUTS area the states and the number of switching actions since switching on are displayed for outputs 1 to 3.

The 7-segment display for the LMS is displayed in the DEVICE STATUS area.

Important To display the external outputs, you must close the field evaluation monitor and re-start it after activation.









How to open the field evaluation monitor:

- In the PROJECT TREE, LMS..., MONITOR, open the device page FIELD EVALUATION MONITOR. In the FIELD EVALUATION MONITOR area you can see the configured fields for the LMS in operation.

4.2 Field evaluation logging

Using the field evaluation logging you can log, save and subsequently play back the operation of LMS. It is used for diagnostics over extended periods, the analysis of malfunctions or the optimisation of processes.

You can operate the field evaluation logging using the buttons on the user interface.

Symbol	Meaning	Comment
	Select events	Using this button you can open a dialog box in which you can select the events to be logged. Possible events are: <ul style="list-style-type: none"> • the evaluation cases 1-10 • the digital outputs 1-3 • the external outputs 1-n
	Open/save recording	Using this button you can open an existing log or save a log.
	Measure	Using this button you can measure the time or the delta for the incremental states between two events.
	Control logging	Using this button you can playback a log, and pause or stop the playback.
	Record to file	Using this button you can save a log direct to a file.
	Resize view	Using this button you can change the size of the view.
	Time/increment axis	Using this button you can define whether the X axis is displayed as a time axis or increment axis.
	Show grid/values	Using this button you can show the background grid and the measured values on the diagram.
	Forward/back	Using this button fast forward or rewind the log or jump to the start of the end of the log.

Tab. 7: Buttons for controlling the field evaluation logging

How to open the field evaluation logging:

- In the PROJECT TREE, LMS..., MONITOR, open the device page FIELD EVALUATION LOGGING.

5 Service/system status



WARNING

Cease operation if the cause of the malfunction has not been clearly identified!

Stop the machine/system if you cannot clearly identify or allocate the error and if you cannot safely rectify the malfunction.

5.1 LMS status

The CURRENT STATUS field shows the current device status.

- undefined = the device is not online
- idle
- set speed
- stand by
- measurement active

With the aid of the TARGET STATUS indication you can see which device status will be achieved.

If, for instance, on an LMS at idle you start the measurement (see [section 3.2.3 “Measurement” on page 12](#)), then the target status immediately changes to “Measurement active”. The motor must first reach the set speed, the current status will only change after a delay.

The CURRENT TEMPERATURE field also indicates the operating temperature in °C.

The DEVICE field shows whether the LMS100 is ready (“Device Ready” status) or not.

How to display the LMS status:



- In the PROJECT TREE, LMS..., SERVICE, open the device page SYSTEM STATUS.

If the device is connected and switched online, information is displayed in the LMS STATUS area on the LMS status, the status of the temperature range and the operating temperature of the LMS.

5.2 Contamination

The LMS determines the amount of contamination on the optics cover using internal tests. The STATE field shows the current device status.

- not contaminated = optics cover clean (or device not online)
- contamination warning = device still ready for operation, optics cover should be cleaned
- contamination error = device not ready for operation, optics cover must be cleaned

How to display the contamination measurement:



- In the PROJECT TREE, LMS..., SERVICE, open the device page SYSTEM STATUS.

In the CONTAMINATION area the contamination status is displayed if a device is connected and online.

5.3 Encoder status

In the ENCODER STATUS area the CURRENT SPEED is displayed if an encoder is connected. In addition the CURRENT DIRECTION OF ROTATION is displayed.

- upward = positive direction of rotation (the increment count increases)
- downward = negative direction of rotation (the increment count decreases)

How to display the encoder status:



- In the PROJECT TREE, LMS..., SERVICE, open the device page SYSTEM STATUS. In the ENCODER STATUS area the CURRENT SPEED and the CURRENT DIRECTION OF ROTATION are displayed.

5.4 Operating data

5.4.1 Device information

In the DEVICE INFORMATION area you will find, with the device online, the MANUFACTURER, DEVICE TYPE, SOFTWARE VERSION, ORDER NUMBER and SERIAL NUMBER for the LMS. Keep this information at hand if, for example, you have questions for SICK support.

How to display the device information:



- In the PROJECT TREE, LMS..., SERVICE, open the device page OPERATING DATA. In the DEVICE INFORMATION area when the device is online you will see information on the LMS.

5.4.2 Operating data

In the OPERATING DATA area in the POWER-ON COUNTER read-only field the number of times the device has been switched on since initial commissioning is displayed.

In the OPERATING HOURS field the total number of operating hours since the initial commissioning of the device is displayed.

In the DAILY OPERATING HOURS field the number of operating hours the device has been running since the last power on is displayed.

How to display the operating data:



- In the PROJECT TREE, LMS..., SERVICE, open the device page OPERATING DATA. In the OPERATING DATA area when the device is online you will see the operating data of the LMS.

5.4.3 Service information

In the SERVICE INFORMATION area you will find, with the device switched online, information on service and configuration:

The name of the user account entered in Windows for configuration is displayed in the LAST USER NAME field.

The date of the last configuration is displayed in the LAST CONFIGURATION field.

You can enter the date of the last maintenance performed in the LAST MAINTENANCE field.

You can enter the date of the next maintenance in the NEXT MAINTENANCE field.

How to display the service information:



- In the PROJECT TREE, LMS..., SERVICE, open the device page OPERATING DATA.
In the SERVICE INFORMATION area when the device is online you will see service information on the LMS.

6 Quickstart mode for the LMS122/123

For the LMS122/123 a Quickstart configuration mode is available with the aid of which the parameters for the LMS122/123 can be easily configured for the needs of object protection.

How to open the Quickstart mode:



- On the PROJECT TREE, open LMS12X_SECURITY, QUICKSTART.
In the MODE selection field, select the STANDARD configuration mode.

How to change to the Expert mode:



- On the PROJECT TREE, open LMS12X_SECURITY, QUICKSTART.
In the MODE selection field, select the EXPERT configuration mode.

6.1 Monitored areas

As supplied nine evaluation fields with pre-configured parameters are available. Evaluation field 1 is configured 0.4 × 0.4 m long, the evaluation fields 2 to 9 are configured 0.05 × 0.05 m long.

You can change and adapt the size and shape of all nine evaluation fields to suit your needs.

NOTICE

Do not delete evaluation fields 2 to 9!

Even if you only need one evaluation field for your application, you should not delete the fields 2 to 9. These are configured so that they are so small, they will not interfere with your application.

If you have nevertheless deleted the fields, you can easily add the fields again, but you should check the related evaluation cases in the Expert mode.

As an alternative you can reset the LMS122/123 to its default values.

Warning: As a result any configuration made will be lost!

Tamper protection

You can configure a 10th field. This field is used for tamper protection (see [Chapter 3.5.10 "Teach-in tamper protection" on page 35](#)).

Important The tamper protection function is only possible with the 10th field. The 10th field cannot be used as a monitoring field.



Working with monitored areas

The fields are displayed in a table in the MONITORED AREAS OVERVIEW area. The field number as well as the name are displayed.

In the ACTIVE column it is indicated when the field is active and the alarm output switches.

- ALWAYS signifies that the field is always active (day configuration and night configuration)
- NIGHT CONFIGURATION signifies that the field is active when the input IN3 is active high
- DAY CONFIGURATION signifies that the field is active when the input IN3 is active low

You can run the following functions using the buttons above the table:

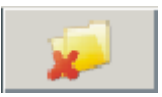
Symbol	Meaning	Comment
	Create evaluation field	Using this button you can create a new evaluation field. The assistant for adding a new evaluation field is opened (see 3.5.1 on page 17).
	Edit evaluation field	You can edit an existing evaluation field using this button. ➤ For this purpose mark one of the evaluation fields in the table and then click the button.
	Copy evaluation field	You can copy an existing evaluation field using this button. During this process, all parameters in the existing field are copied to the new field. ➤ For this purpose mark one of the evaluation fields in the table and then click the button.
	Delete evaluation field	You can delete an existing evaluation field using this button. ➤ For this purpose mark one of the evaluation fields in the table and then click the button.

Tab. 8: Buttons for managing the evaluation fields

6.2 Response behaviour

Object size

The configured object size defines from which object size the evaluation field is considered infringed and the alarm output switches.

Default setting is an object size of 40 mm, the sizes 3, 30, 40, 100 and 300 mm are available.

Here 30, 40 and 300 mm correspond to the object sizes in accordance with VdS test class C.

Tripping time

The configured tripping time defines how long an object must be in the evaluation field until the field is considered infringed and the alarm output switches.

Default setting is 240 ms, the tripping times 120, 240, 500 and 1000 ms are available.

6.3 Alarm message

Output

The alarm message is set on the alarm output. This feature cannot be changed in the Quickstart mode.

Duration of response

After the field infringement (alarm message) has been removed, the alarm output retains its status for the time configured.

Default setting is 3 s, the durations of response of 1, 3, 7 and 10 s are available.

6.4 Malfunction message

If there are malfunctions due to an incorrect connection layout on the inputs, due to cables being pulled off, or due to errors on the LMS, this situation is signalled on the error output on the LMS122/123. The output switches to low.

Output

The malfunction message is set on the error output. This feature cannot be changed in the Quickstart mode.

Duration of response

After the end of the malfunction, the error output remains set for the time configured.

Default setting is 3 s, the durations of response of 1, 3, 7 and 10 s are available.

6.5 General

In the GENERAL area the parameters for the Ethernet interface can be configured.

The Ethernet interface has a data transmission rate of 10/100 MBit. The interface is a TCP/IP interface. Full duplex and half duplex are supported.

The Ethernet interface allows the configuration of the LMS as well as the output of measured values.

Important If you change the parameters for the Ethernet interface, to apply the parameters you must first save the data in the LMS in non-volatile memory and then restart the LMS. The APPLY button is available for this action. If your PC/notebook is connected to the LMS using the Ethernet interface, the connection to the device will be lost. You must then scan for the LMS again in SOPAS ET.

How to configure the Ethernet interface:

- In the GENERAL area enter the necessary parameters for the operation of the Ethernet interface.



6.6 Field evaluation monitor

In the field evaluation monitor you can use the same tools to configure the view as in the field editor (see [section 3.5.3 “Adapting the field editor view” on page 18](#)).

Using the field evaluation monitor, you can analyse whether and how evaluation fields are infringed and how the outputs on the LMS behave.

Important The indication of events, such as field or contour infringements, appears on the monitor with a slight delay.

Evaluation fields

The status of the fields is displayed in different colours:

- Green: The evaluation field has not been infringed.
- Yellow: The evaluation field has been infringed.

Outputs

In the OUTPUTS area the status of the relay outputs is displayed:

- Grey: The output is not switched (closed).
- Yellow: The output is switched (open).

Inputs

In the INPUTS area the level on the digital inputs is displayed:

- Grey: 0 V are present (low active).
- Yellow: 24 V are present (high active).

7 Glossary

Note For other terms, see also the online help for the SOPAS ET configuration software.

Auxiliary interface

Auxiliary interface (RS-232) on the LMS with fixed measured data output format. Using this interface it is always possible to access the LMS using the SOPAS ET configuration software. Is used, among other tasks, for the output of system messages and error messages. Can be used with various functions.

Download

Transmission of the parameter set that has been modified offline in the SOPAS ET configuration software from the PC to the LMS. SOPAS ET transmits either always a complete copy to the memory (RAM) of the LMS (menu COMMUNICATION, DOWNLOAD ALL PARAMETERS TO DEVICE) or only the parameter that has just been edited with the aid of the context menu opened using the right mouse button (menu COMMUNICATION, DOWNLOAD MODIFIED PARAMETERS TO DEVICE). With the menu LMS_FIELD EVAL, PARAMETER, SAVE PERMANENT, the parameter set is saved permanently in the EEPROM of the LMS.

Line scanner

Scanner that very rapidly deflects its focused laser beam with the aid of a polygon mirror wheel with mirrors parallel to the axis. In this way the scanner generates a dot of light in the measuring plane that repeatedly runs along a straight line and appears to be a "stationary" scan line due to the relative slow response of the human eye.

Parameter set

Data set using which the functions implemented in the LMS are initialised and activated. Is transmitted from the LMS to SOPAS ET and in the reverse direction using UPLOAD or DOWNLOAD respectively.

SOPAS ET

Configuration software, can be used with Windows 2000/XP/Vista. Is used for the offline configuration (adaptation to the read situation on-site) and the online operation of the LMS in the dialog box.

SOPAS ET setup help

Online help that supports the usage of the SOPAS ET configuration software. The functions of the parameters for the LMS are explained in the help and the related value ranges are given. Can be used with an HTML browser, e.g. Internet Explorer and can be opened from SOPAS ET setup.

Upload

Transmission of the parameter set from the LMS to the PC into the SOPAS ET configuration software. The values for the parameters are displayed on the file cards of the configuration software. Prerequisite for the modification of the current parameter set.

8 Index

Numerics

7-segment display 48

A

Abbreviations 4

Activation of an evaluation case 38

Alarm message 56

Angular resolution 10

Auxiliary interface 43

Available 12

B

Baud rate 45

Blanking 39

Blanking window 13

C

CAN 45

CAN baud rate 45

CAN device number 42

CAN ID 42

CAN operating mode 45

Configuration 8

Configuration date 53

Contamination 51

Contamination measurement 12

Contour as reference 32, 35

Contour monitoring with blanking 40

D

Data recording 50

Day configuration and night configuration 55

Debounce 46

Device ID 42

Device information 52

Device name 42

Device Ready 46

Device type 52

Duration of response 56

Dynamic field 26

E	
Ethernet interface	44
Ethernet interface LMS122/123	56
Evaluation cases	37
Evaluation field	
Dynamic.....	17
Rectangular.....	17
Segmented.....	17
Teach-in	29
Evaluation fields.....	16
Evaluation strategy	38
Expanded response time.....	41
Expert mode	54
External switching outputs	47
F	
Field editor view	18
Field evaluation logging.....	50
Field evaluation monitor LMS122/123	57
Filter	13
Fog filter	13
G	
Glare.....	41
H	
Heartbeat message	43, 44, 45
Highly available	12
Host interface.....	43
I	
I/O operator	41
Increment source.....	14
Inputs.....	37, 45
L	
LEDs.....	48
Logging of the field evaluation	50

M

Maintenance date	53
Malfunction message.....	56
Manipulation prevention	41
Mean filter.....	14
Monitor	49
Monitored areas	54
Monitoring devices	42

N

N-pulse-to-1-pulse filter.....	13
--------------------------------	----

O

Object size.....	55
Operating data	52
Operating hours	52
Operating mode	45
Output format	41
Outputs.....	46

P

Password.....	8
Pixel evaluation.....	38

Q

Quickstart mode	54
-----------------------	----

R

Rectangular field	23
Reference.....	32
Resetting configuration.....	9
Response time with blanking	39
Response time with contour monitoring.....	40
Response time with pixel evaluation	38

S

Save as PDF 9

Save configuration permanently 58

Save parameters 9

Save parameters permanently 58

Scanning frequency 10

Sensitive 12

Serial number for the device 52

Setting end points 19

Setting start points 23

Shading 41

Software version 2

Starting angle 11

Status 51

Stopping angle 11

Switching outputs 46

Switching outputs external, outputs external 47

T

Tamper protection 54

Tripping time 55

Australia

Phone +61 3 9497 4100
1800 33 48 02 – tollfree
E-Mail sales@sick.com.au

Belgium/Luxembourg

Phone +32 (0)2 466 55 66
E-Mail info@sick.be

Brasil

Phone +55 11 3215-4900
E-Mail sac@sick.com.br

Ceská Republika

Phone +420 2 57 91 18 50
E-Mail sick@sick.cz

China

Phone +852-2763 6966
E-Mail ghk@sick.com.hk

Danmark

Phone +45 45 82 64 00
E-Mail sick@sick.dk

Deutschland

Phone +49 211 5301-301
E-Mail kundenservice@sick.de

España

Phone +34 93 480 31 00
E-Mail info@sick.es

France

Phone +33 1 64 62 35 00
E-Mail info@sick.fr

Great Britain

Phone +44 (0)1727 831121
E-Mail info@sick.co.uk

India

Phone +91-22-4033 8333
E-Mail info@sick-india.com

Israel

Phone +972-4-999-0590
E-Mail info@sick-sensors.com

Italia

Phone +39 02 27 43 41
E-Mail info@sick.it

Japan

Phone +81 (0)3 3358 1341
E-Mail support@sick.jp

Nederlands

Phone +31 (0)30 229 25 44
E-Mail info@sick.nl

Norge

Phone +47 67 81 50 00
E-Mail austefjord@sick.no

Österreich

Phone +43 (0)22 36 62 28 8-0
E-Mail office@sick.at

Polska

Phone +48 22 837 40 50
E-Mail info@sick.pl

Republic of Korea

Phone +82-2 786 6321/4
E-Mail kang@sickkorea.net

Republika Slovenija

Phone +386 (0)1-47 69 990
E-Mail office@sick.si

România

Phone +40 356 171 120
E-Mail office@sick.ro

Russia

Phone +7 495 775 05 34
E-Mail info@sick-automation.ru

Schweiz

Phone +41 41 619 29 39
E-Mail contact@sick.ch

Singapore

Phone +65 6744 3732
E-Mail admin@sicksgp.com.sg

Suomi

Phone +358-9-25 15 800
E-Mail sick@sick.fi

Sverige

Phone +46 10 110 10 00
E-Mail info@sick.se

Taiwan

Phone +886 2 2375-6288
E-Mail sales@sick.com.tw

Türkiye

Phone +90 216 587 74 00
E-Mail info@sick.com.tr

United Arab Emirates

Phone +971 4 8865 878
E-Mail info@sick.ae

USA/Canada/México

Phone +1(952) 941-6780
1 800-325-7425 – tollfree
E-Mail info@sickusa.com

More representatives and agencies
in all major industrial nations at
www.sick.com