

Flexi Loop

Safe Series Connection hardware

SICK
Sensor Intelligence.



Described product

Flexi Loop

Manufacturer

SICK AG
Erwin-Sick-Str. 1
79183 Waldkirch
Germany

Legal information

This work is protected by copyright. Any rights derived from the copyright shall be reserved for SICK AG. Reproduction of this document or parts of this document is only permissible within the limits of the legal determination of Copyright Law. Any modification, abridgment or translation of this document is prohibited without the express written permission of SICK AG.

The trademarks stated in this document are the property of their respective owner.

© SICK AG. All rights reserved.

Original document

This document is an original document of SICK AG.



Contents

1	About this document.....	6
1.1	Function of this document.....	6
1.2	Scope.....	6
1.3	Target groups of these operating instructions.....	6
1.4	Additional information.....	7
1.5	Symbols and document conventions.....	7
2	Safety information.....	8
2.1	General safety notes.....	8
2.2	Intended use.....	8
2.3	Improper use.....	8
2.4	Requirements for the qualification of personnel.....	9
3	Product description.....	10
3.1	Structure and function.....	10
3.1.1	System requirements.....	10
3.1.2	Safety by means of Flexi Loop.....	11
3.1.3	Subdivision into a segment, section, and line.....	12
3.1.4	Supply of power.....	13
3.2	Principle of operation.....	14
3.2.1	Operating principle of Flexi Loop on a programmable SICK safety controller.....	14
3.2.2	Operating principle of Flexi Loop on a Flexi Classic.....	15
3.2.3	Protection against tampering.....	19
3.3	Device components.....	19
3.3.1	Flexi Loop node.....	19
3.3.2	Flexi Loop terminator.....	20
3.3.3	Flexi Loop accessories.....	20
3.3.4	Status indicators.....	22
4	Project planning.....	24
4.1	Total current.....	24
4.1.1	Permissible total current of a section.....	24
4.1.2	Permissible inrush current.....	24
4.1.3	Other limits.....	24
4.1.4	Connection facilities.....	25
4.1.5	Division into sections.....	27
4.2	Voltage drop via cables, Flexi Loop nodes and Flexi Loop accessories	28
4.2.1	Examples for the voltage drop.....	28
4.3	Supply of OSSD devices.....	31
4.4	Integration in the electrical control system.....	31
4.4.1	Implementation of reset.....	31
4.4.2	Implementation of a safety locking device.....	33
4.5	Testing plan.....	36

5	Mounting.....	37
5.1	Mounting in a cable channel.....	37
5.2	Mounting with cable tie.....	37
5.3	Mounting the C-Fix bracket and Flexi Loop nodes.....	38
6	Electrical installation.....	39
6.1	Notes on cULus.....	39
6.2	Connecting.....	39
6.2.1	Connection to programmable SICK safety controller.....	39
6.2.2	Connection to Flexi Classic.....	41
6.2.3	Connections of the Flexi Loop nodes.....	42
6.2.4	Connecting the Flexi Loop nodes.....	42
6.2.5	Connections of the EMSS Flexi Loop node.....	43
6.2.6	Connections of the OSSD Flexi Loop node.....	44
6.2.7	Connections of the PWRI power supply accessory.....	45
6.2.8	Connections of the MSTR1 Flexi Loop accessory.....	46
6.2.9	Connections of the MSTR2 Flexi Loop accessory.....	47
6.2.10	Connections of the DIAG Flexi Loop accessory.....	48
6.2.11	Connection of Flexi Loop YCON1 and YCON2 adapters.....	48
6.2.12	Connections of the Flexi Loop YCON1 adapter.....	49
6.2.13	Connections of the Flexi Loop YCON2 adapter.....	50
7	Configuration.....	52
7.1	Manipulation protection using the Flexi Loop MSTR accessory.....	52
7.1.1	Configuring the manipulation protection.....	52
7.1.2	Deactivating the manipulation protection.....	53
7.2	Security.....	53
7.3	Configuration with a standard controller.....	53
7.3.1	Prerequisites.....	54
7.3.2	Configuring the hardware.....	54
7.3.3	Options for application design in the PLC.....	58
8	Commissioning.....	63
8.1	Switching on.....	63
8.2	Commissioning with the Flexi Loop DIAG or MSTR accessory.....	63
8.3	Check during commissioning and modifications.....	63
9	Troubleshooting.....	64
9.1	In the event of faults or errors.....	64
9.2	Indications of the LEDs.....	64
9.2.1	MS LED.....	64
9.2.2	LEDs of the EMSS Flexi Loop nodes.....	66
9.2.3	LEDs of the OSSD Flexi Loop nodes.....	67
9.2.4	LEDs of the PWRI power supply accessory.....	67
9.2.5	LEDs of the MSTR1 Flexi Loop accessory.....	68
9.2.6	LEDs of the MSTR2 Flexi Loop accessory.....	69

9.2.7	LEDs of the DIAG Flexi Loop accessory.....	71
9.3	Extended diagnostics.....	72
9.3.1	Diagnostics using the MSTR2 Flexi Loop accessory.....	72
9.3.2	Test tools for the configuration.....	74
10	Decommissioning.....	76
10.1	Disposal.....	76
11	Technical data.....	77
11.1	Data sheet.....	77
11.1.1	Overall system.....	77
11.1.2	All Flexi Loop nodes and Flexi Loop accessories.....	77
11.1.3	Flexi Loop EMSS nodes.....	79
11.1.4	Flexi Loop OSSD nodes.....	80
11.1.5	Terminator.....	80
11.1.6	PWRI power supply accessory.....	80
11.1.7	MSTR Flexi Loop accessory.....	81
11.2	Dimensional drawings.....	82
11.2.1	Flexi Loop node dimensional drawing.....	82
11.2.2	PWRI power supply accessory dimensional drawing.....	83
11.2.3	Terminator dimensional drawing.....	83
11.2.4	C-Fix bracket dimensional drawing.....	84
11.2.5	MSTR Flexi Loop accessory dimensional drawing.....	85
11.2.6	DIAG Flexi Loop accessory dimensional drawing.....	86
11.2.7	YCON Flexi Loop adapter dimensional drawing.....	86
11.3	Compatibility.....	87
12	Ordering information.....	88
12.1	Scope of delivery.....	88
12.2	Flexi Loop node.....	88
12.3	Flexi Loop accessories.....	88
13	Accessories.....	90
13.1	Plug connectors.....	90
13.2	Pre-assembled cables.....	90
13.3	Mounting accessories.....	91
14	Annex.....	92
14.1	Conformities and certificates.....	92
14.1.1	EU declaration of conformity.....	92
14.1.2	UK declaration of conformity.....	92
14.2	Checklists.....	92
14.2.1	Checklist for initial commissioning and commissioning.....	92
15	List of figures.....	94
16	List of tables.....	96

1 About this document

1.1 Function of this document

These operating instructions contain the information required during the life cycle of the Flexi Loop safe series connection.

These operating instructions are to be made available to all those who work with the Flexi Loop safe series connection.

1.2 Scope

Product

This document applies to the following products:

- Product code: Flexi Loop
- “Operating instructions” type label entry: 8015834

Document identification

Document part number:

- This document: 8015836
- Available language versions of this document: 8015834

You can find the current version of all documents at www.sick.com.

Other documents relevant for the product

Table 1: Available documents

Document	Title	Part number
Operating instructions	Flexi Loop in the Flexi Soft Designer Software	8014521
Operating instructions	Flexi Loop in the Safety Designer Software	8018174
Operating instructions	Flexi Soft modular safety controller hardware	8012999
Operating instructions	Flexi Compact safety controller	8024573
Operating instructions	Flexi Classic Modular Safety Controller	8011562
Additional Information on IO-Link	FLA-MSTR00002	8017450
Competence brochure	Guide for Safe Machinery	8008007

1.3 Target groups of these operating instructions

Some sections of these operating instructions are intended for certain target groups. However, the entire operating instructions are relevant for intended use of the product.

Table 2: Target groups and selected sections of these operating instructions

Target group	Sections of these operating instructions
Project developers (planners, developers, designers)	"Project planning", page 24 "Configuration", page 52 "Technical data", page 77
Installers	"Mounting", page 37
Electricians	"Electrical installation", page 39

Target group	Sections of these operating instructions
Safety experts (such as CE authorized representatives, compliance officers, people who test and approve the application)	"Project planning", page 24 "Configuration", page 52 "Commissioning", page 63 "Technical data", page 77 "Checklists", page 92
Operators	"Troubleshooting", page 64
Maintenance personnel	"Troubleshooting", page 64

1.4 Additional information

www.sick.com

The following information is available on the Internet:

- Data sheets and application examples
- CAD data and dimensional drawings
- Certificates (e.g. EU declaration of conformity)
- Guide for Safe Machinery Six steps to a safe machine

1.5 Symbols and document conventions

Warnings and other notes



DANGER

Indicates a situation presenting imminent danger, which will lead to death or serious injuries if not prevented.



WARNING

Indicates a situation presenting possible danger, which may lead to death or serious injuries if not prevented.



CAUTION

Indicates a situation presenting possible danger, which may lead to moderate or minor injuries if not prevented.



NOTICE

Indicates a situation presenting possible danger, which may lead to property damage if not prevented.



NOTE

Highlights useful tips and recommendations as well as information for efficient and trouble-free operation.

Instructions to action

- ▶ The arrow denotes instructions to action.
- 1. The sequence of instructions for action is numbered.
- 2. Follow the order in which the numbered instructions are given.
- ✓ The check mark denotes the result of an instruction.

2 Safety information

2.1 General safety notes

Integrating the product

**DANGER**

The product can not offer the expected protection if it is integrated incorrectly.

- ▶ Plan the integration of the product in accordance with the machine requirements (project planning).
 - ▶ Implement the integration of the product in accordance with the project planning.
-

Mounting and electrical installation

**DANGER**

Death or severe injury due to electrical voltage and/or an unexpected startup of the machine

- ▶ Make sure that the machine is (and remains) disconnected from the voltage supply during mounting and electrical installation.
 - ▶ Make sure that the dangerous state of the machine is and remains switched off.
-

Repairs and modifications

**DANGER**

Improper work on the product

A modified product may not offer the expected protection if it is integrated incorrectly.

- ▶ Apart from the procedures described in this document, do not repair, open, manipulate or otherwise modify the product.
-

2.2 Intended use

The Flexi Loop safe series connection is an expansion for the Flexi Classic safety controller and the programmable SICK Flexi Soft and Flexi Compact safety controller.

The Flexi Loop safe series connection must only be used within the limits of the prescribed and specified technical data and operating conditions at all times.

The product may be used in safety functions.

The product must only be used within the limits of the prescribed and specified technical specifications and operating conditions at all times.

Incorrect use, improper modification or manipulation of the product will invalidate any warranty from SICK; in addition, any responsibility and liability of SICK for damage and secondary damage caused by this is excluded.

2.3 Improper use

Among others, the Flexi Loop safe series connection is not suitable for the following applications:

- outdoors
- under water
- in explosive environments

2.4 Requirements for the qualification of personnel

The product must be configured, installed, connected, commissioned, and serviced by qualified safety personnel only.

Project planning

You need safety expertise to implement safety functions and select suitable products for that purpose. You need expert knowledge of the applicable standards and regulations.

Mounting, electrical installation and commissioning

You need suitable expertise and experience. You must be able to assess if the machine is operating safely.

Configuration

You need suitable expertise and experience. You must be able to assess if the machine is operating safely.

Operation and maintenance

You need suitable expertise and experience. You must be instructed in machine operation by the machine operator. For maintenance, you must be able to assess if the machine is operating safely.

3 Product description

3.1 Structure and function

A safe series connection consists of individual Flexi Loop nodes that are connected with the safety controller. The Flexi Loop nodes enable information to be collected from safety sensors and safety switches distributed within a space.

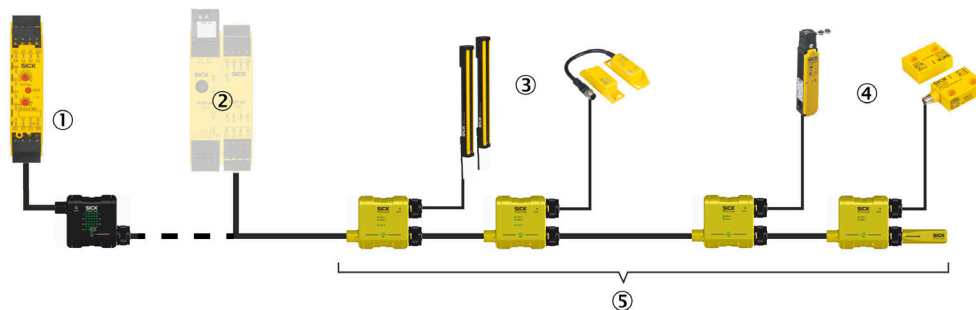

Figure 1: Flexi Loop safe series connection

- ① Safety controller: Flexi Classic
- ② Programmable SICK safety controller: Flexi Soft or Flexi Compact
- ③ Safety sensors with monitored semiconductor output (OSSD)
- ④ Electro-mechanical safety switch (EMSS)
- ⑤ Flexi Loop

Dual-channel, equivalent switching electro-mechanical safety switches (e.g. reed switches) or safety sensors with monitored semiconductor output (OSSD) (e.g. safety light curtains or safety laser scanners) can be connected to Flexi Loop nodes.

The primary function of the Flexi Loop nodes is to safely and quickly monitor the connected switches and sensors in order to transmit a mutual switching criterion to the safety controller.

Diagnostic functions make it possible to localize which safety sensor or safety switch has switched off for what reason. Testing detects discrepancy or sequence errors as well as cross- and short-circuit of the sensors or switches.

Non-safe inputs and outputs also make it possible to evaluate situations (e.g. contamination) on the monitored system or to trigger functions (e.g. lighting up lamps and activating door locks).

3.1.1 System requirements

Programmable SICK safety controller: Flexi Soft

The Flexi Loop safe series connection can be connected to a main module or to a Flexi Soft safety controller extension module. The following prerequisites apply:

- one main module
 - FX3-CPUx with firmware V3.xx or higher
- one or more expansion modules
 - FX3-XTIO with firmware V3.xx or higher
 - FX3-XTDI with firmware V3.xx or higher
 - FX3-XTDS with firmware V3.xx or higher

Programmable SICK safety controller: Flexi Compact

The Flexi Loop safe series connection can be connected to a main module or a Flexi Compact safety controller extension module. The following prerequisites apply:

- A main module
 - FLX3-CPUx
- one or more expansion modules
 - FLX3-XTIO
 - FLX3-XTDI

Flexi Classic safety controller

The Flexi Loop safe series connection is connected to the main module or a Flexi Classic safety controller extension module with a Flexi Loop MSTR accessory. The following prerequisites apply:

- one main module
 - UE410-MU version 13.45 or higher
- one Flexi Loop MSTR1 or MSTR2 accessory
- one or more extension modules (optional)
 - UE410-XU version 13.45 or higher
 - UE410-8DI version 13.45 or higher

3.1.2 Safety by means of Flexi Loop

Fault masking

If tested dual-channel equivalent safety switches are connected in series, errors cannot be detected reliably. The following example shows such a situation.

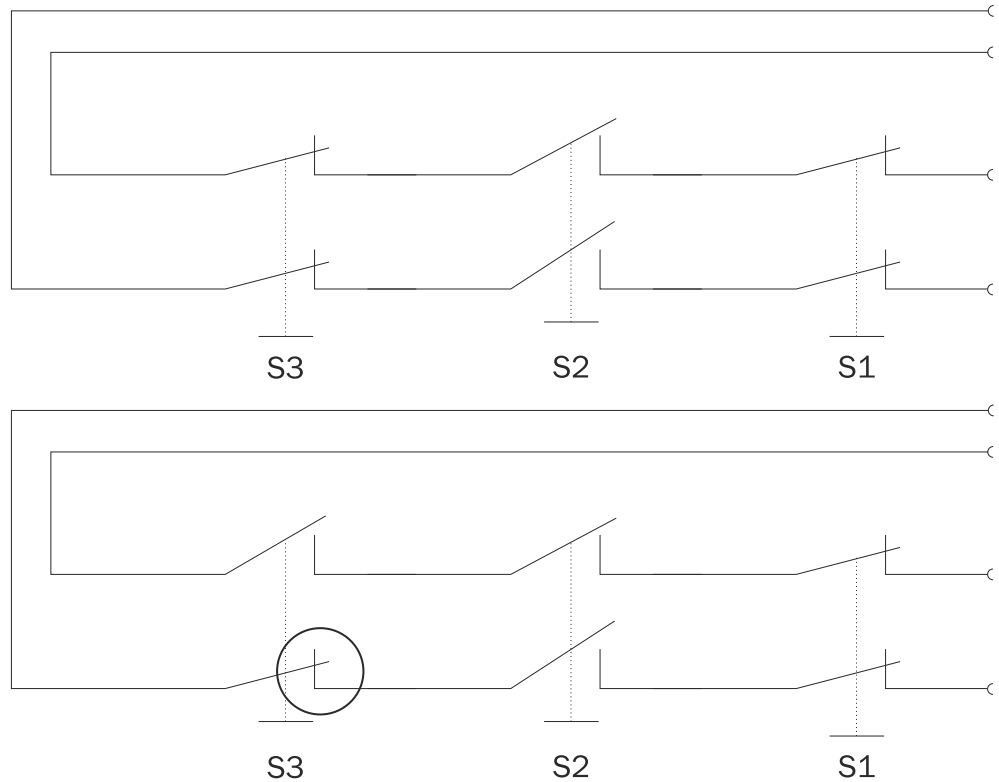

Figure 2: Error masking

If the S2 switch is opened correctly, the system, for example, will be switched off. If the S3 switch is now also opened, the fault in S3 cannot be identified (fault masking). If the S3 switch is closed before S2, the fault remains undiscovered. This problem is called fault masking.

Safety thanks to the Flexi Loop

Flexi Loop has no fault masking because the connected sensors are monitored individually. Flexi Loop therefore achieves a performance level up to PL e.

3.1.3 Subdivision into a segment, section, and line

The Flexi Loop safe series connection is subdivided into a segment, section and line:

- **Segment**
A segment starts at the safety controller or the FL_OUT female connector of the upstream Flexi Loop node and ends at the FL_OUT female connector of the Flexi Loop node (see "Connections of the Flexi Loop nodes", page 42). A segment also includes the connection cable and the supply line to the device connected to the Flexi Loop node .
- **section**
A section extends from a supply of power to the next accessory for the supply of power or to the terminator.
- **Line**
A line consists of the complete safe series connection from the connection to the safety controller to the terminal.

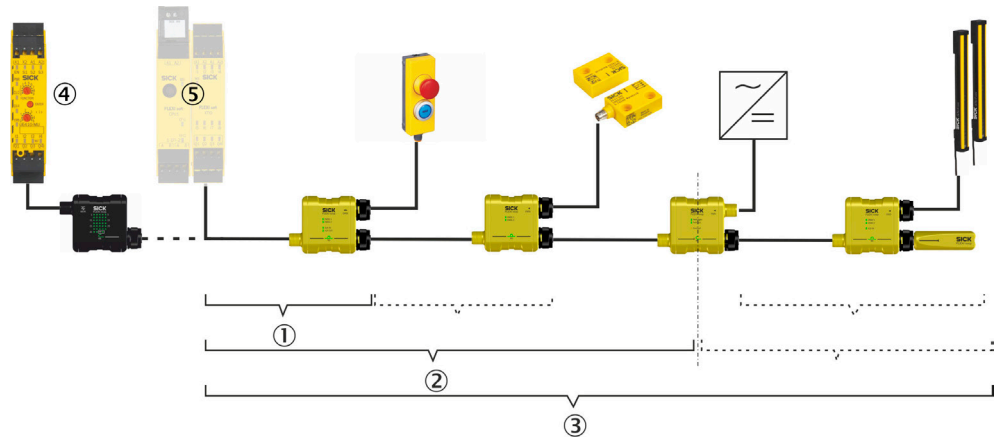

Figure 3: Subdivision of the safe series connection

- ① Segment
- ② Section
- ③ String
- ④ Flexi Classic safety controller
- ⑤ Programmable SICK safety controller: Flexi Soft or Flexi Compact

The Flexi Loop safe series connection is structured as a line topology. It must always be terminated with an FLT-TERM00001 terminal after the last Flexi Loop node.



NOTE

The terminator must be connected directly to the Flexi Loop node, it is not allowed to be connected via a cable.

Power supply and diagnostic accessories can be installed between the Flexi Loop nodes.

Within Flexi Loop, the connection is made with standard 5-pin unshielded cables. Cables up to 100 m in length can be laid between the individual Flexi Loop nodes.

Sensors or switches are connected with 5-pin or 8-pin unshielded cables with M12 male connectors (see "Pre-assembled cables", page 90). A series of SICK sensors or switches can be connected with 1:1 cables (male/female connector).

The Flexi Loop YCON1 and YCON2 adapters can be used to decouple the non-safe inputs and outputs of the 8-pin Flexi Loop EMSS nodes and the 8-pin Flexi Loop OSSD nodes. The cables for the sensors or switches must not exceed a length of 10 m ¹⁾.

3.1.4 Supply of power



NOTICE

If multiple power supply units in a Flexi Loop section are connected in parallel, the loss of the GND connection can lead to overcurrent and cable fires.

- ▶ Connected OSSD devices should always be supplied with power via the OSSD female connector of the Flexi Loop node FLN-OSSD1000105 or FLN-OSSD1100108.
- ▶ OSSD devices must always be connected to the same voltage supply as the Flexi Loop node to which they are connected.
- ▶ Always use the power supply accessory to connect additional power supply units.
- ▶ **Never** use a separate power supply unit to supply power directly to a connected OSSD device.

The power supply accessory is characterized by:

- Voltage supply to the Flexi Loop safe series connection and connection of additional voltage supply units ([see "Connection facilities", page 25](#))
- electrical isolation in individual sections
- Disconnection of the line or the section in the event of overcurrent

Depending on the number of Flexi Loop nodes, the length of the cables, and the power consumption of the connected sensors or actuators, a voltage supply from a single power supply unit might not be sufficient. Should this be the case, additional power supply units can be connected with the power supply accessory.

¹⁾ Including the connection cables for the Flexi Loop YCON1 and YCON2 adapters, if used

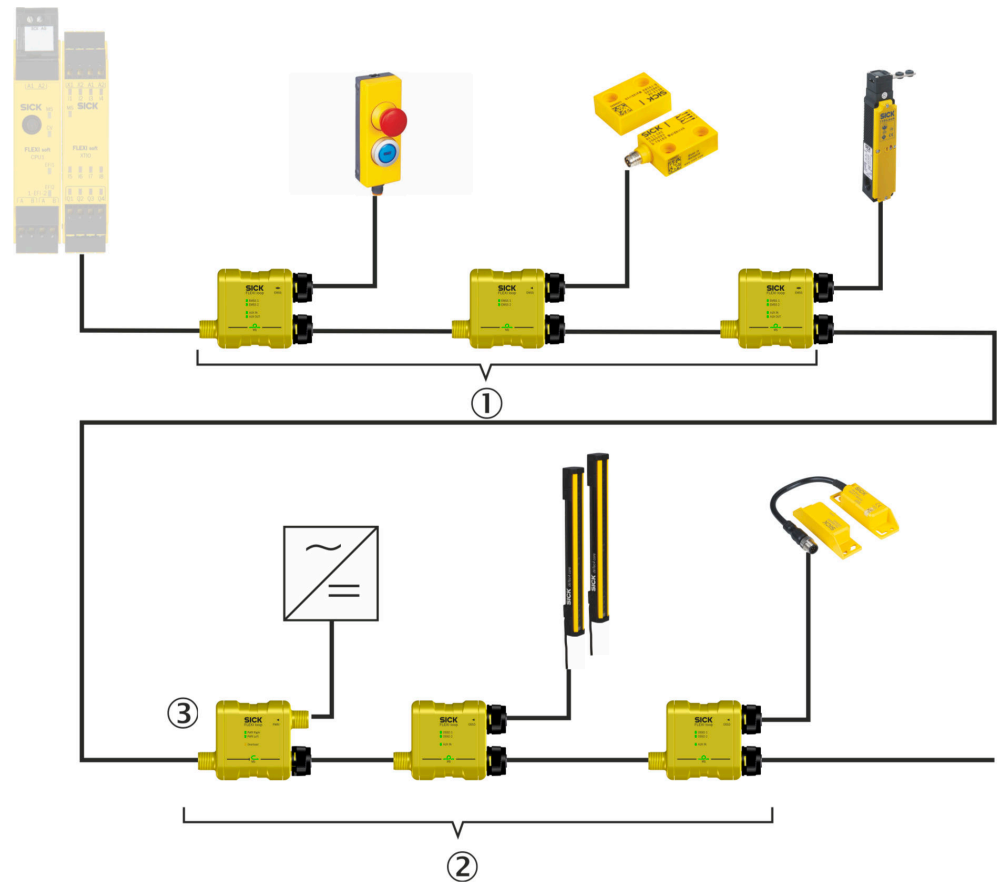

Figure 4: Supply of power

- ① Section 1
- ② Section 2
- ③ Supply of power for section 2

3.2 Principle of operation

3.2.1 Operating principle of Flexi Loop on a programmable SICK safety controller

Overview

The safe I/O modules form the interface to the safety controller. The data traffic of the safe series connection is integrated into the data traffic of the safety controller.

Safe cut-off path

The safety information of the connected switches and sensors is summed and transmitted quickly and safely to the safety controller.

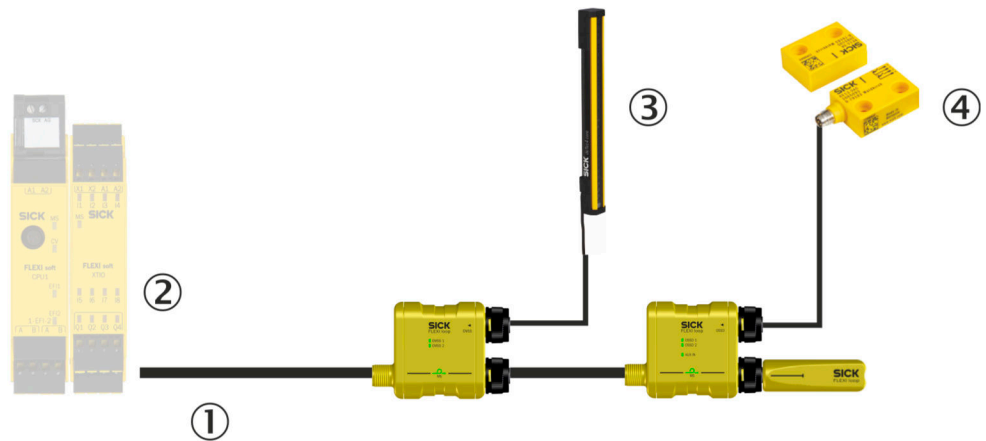

Figure 5: Safe cut-off path

- ① Safe cut-off path
- ② I/O module of the programmable SICK safety controller: Flexi Soft or Flexi Compact
- ③ Safety sensors with monitored semiconductor output (OSSD)
- ④ Electro-mechanical safety switch (EMSS)

Diagnostic information

In addition, non-safe diagnostic information about the states within the safe series connection and the Flexi Loop nodes is transmitted to the safety controller.

Further processing of information in the logic editor

The safety information and the non-safe diagnostic information can be processed further in the logic of the safety controller or, for example, forwarded to a PLC via a gateway.

3.2.2 Operating principle of Flexi Loop on a Flexi Classic

Flexi Loop MSTR1 or MSTR2 accessory

The safe series connection is connected to the Flexi Classic safety controller using the Flexi Loop MSTR1 or MSTR2 accessory. The Flexi Loop accessory enables the safe series connection to function as a dual-channel equivalent opening safety switch. The safety information from the connected switches and sensors is collated and sent quickly and securely to the inputs of the safety controller.

In the example Flexi Loop is connected to the input control circuit A. Program 1 is selected.

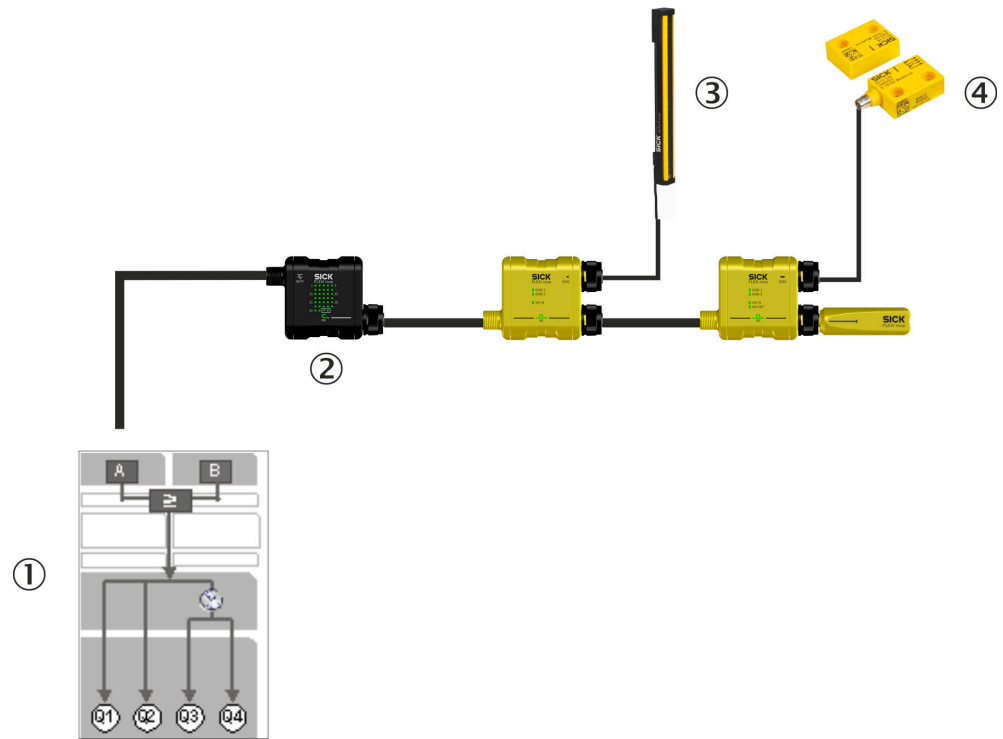

Figure 6: Flexi Loop MSTR1 accessory on the Flexi Classic safety controller

- ① Program in Flexi Classic
- ② MSTR1 Flexi Loop accessory
- ③ Safety sensors with monitored semiconductor output (OSSD)
- ④ Electro-mechanical safety switch (EMSS)

If a safety sensor or a safety switch at a Flexi Loop node switches to the OFF state, the Flexi Loop MSTR1 or MSTR2 accessory can be relied upon to forward this cut-off information.

In the example, program 1 is cutting off the Q1 and Q2 OSSDs of the safety controller. You can find detailed information about the safety controller programs in the “Flexi Classic Modular Safety Controller” operating instructions (SICK part no. 8011737).

I/O functions of the Flexi Loop MSTR2 accessory

The Flexi Loop MSTR2 accessory supports non-safe I/O functions in addition to the functions of the Flexi Loop MSTR1 accessory.

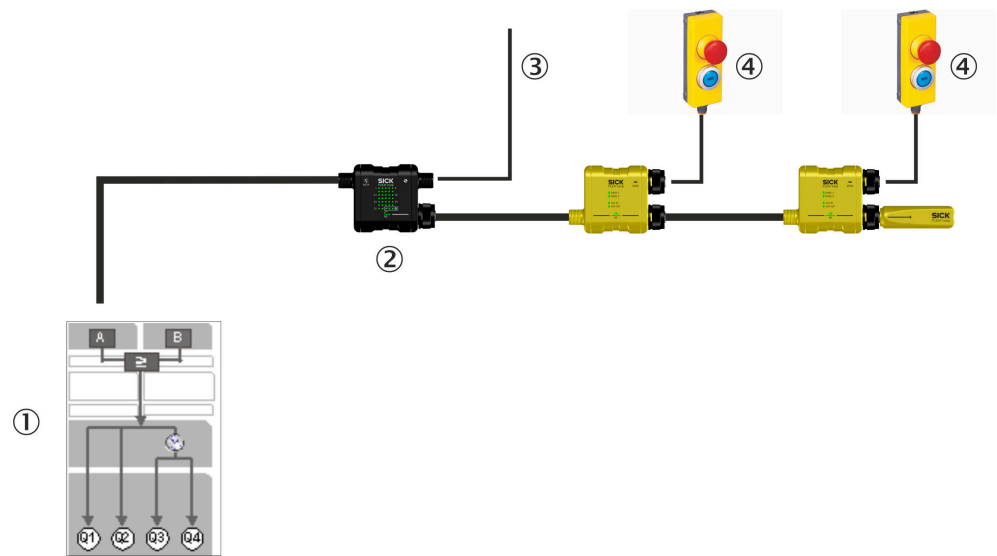

Figure 7: I/O functions of the Flexi Loop MSTR2 accessory

- ① Program in Flexi Classic
- ② MSTR2 Flexi Loop accessory
- ③ I/O functions
- ④ Emergency stop pushbutton with reset button and light for reset required

In the configuration from the factory the AUX_IN of the MSTR2 Flexi Loop accessory switches all AUX_OUT of the Flexi Loop nodes. The AUX_IN of the Flexi Loop nodes switch the AUX_OUT of the MSTR2 Flexi Loop accessory.

The non-safe input of the Flexi Loop MSTR2 accessory switches non-safe outputs of the Flexi Loop nodes. You can use this function, for example, to control lamps or to implement a lock.

The non-safe output of the Flexi Loop MSTR2 accessory collects the statuses of the non-safe inputs of the Flexi Loop nodes. The statuses are linked with a logical OR operation prior to delivery (factory setting). You can use this function, for example, for a group reset signal.

The factory settings for the MSTR2 Flexi Loop accessory can be configured via IO-Link.

IO-Link functions of the MSTR2 Flexi Loop accessory

If the IO-Link is connected, for example, to a PLC, then the MSTR2 Flexi Loop accessory and the PLC exchange data via this interface.

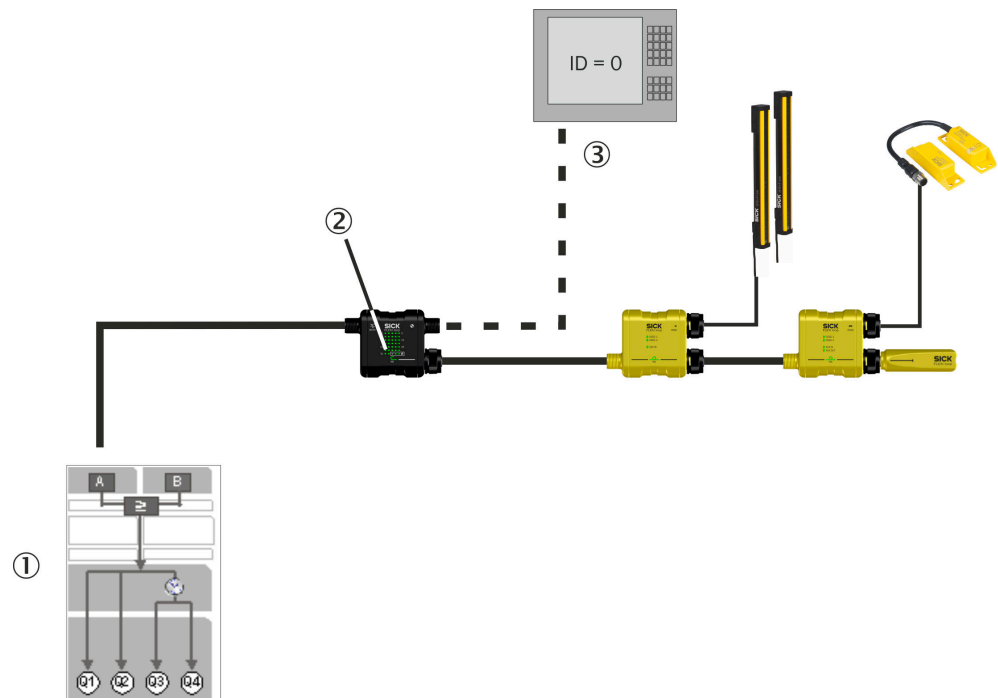

Figure 8: IO-Link functions of the MSTR2 Flexi Loop accessory

- ① Program in Flexi Classic
- ② LED display
- ③ Diagnostics information on the PLC

The parameter list with all data that can be read and written is available as a separate document (SICK part number 8017450).

Process data

The PLC and the MSTR2 Flexi Loop accessory communicate cyclically in a data frame for process data:

- Flexi Loop transmits 4 bytes of input data to the PLC. These bytes contain the status of the non-safe inputs AUX_IN of the Flexi Loop nodes.
- Flexi Loop receives 4 byte of output data from the PLC. These bytes contain the commands for the non-safe outputs AUX_OUT of the Flexi Loop nodes.

Service data

The PLC communicates acyclically with the MSTR2 Flexi Loop accessory for service data. The service data offer the following options:

- execution of commands
- configuration of the parameters for the Flexi-Loop string and the individual Flexi Loop nodes
- reading the parameter values and statuses of the Flexi Loop string and the Flexi Loop nodes

Events

Different system events can be tracked during operation. The following events are available:

- Status of the cut-off path
- Safety controller synchronization
- Flexi Loop not in operation
- cable connection
- dynamic error

- static error
- critical error
- configuration difference

3.2.3 Protection against tampering

Programmable SICK safety controller

The safety controller stores the node type and number of nodes within a safe series connection.

This prevents Flexi Loop nodes from being replaced with other types of nodes as well as preventing them from being removed, added, or jumpered. In specific cases, this protection against manipulation can be disabled (see the “Flexi Loop in the Flexi Soft Designer” operating instructions, part no. 8014522, or “Flexi Loop in the Safety Designer, part no. 8018174).

Flexi Classic safety controller with Flexi Loop MSTR accessories

The Flexi Loop MSTR accessory stores the number of nodes within a safe series connection.

In this way it is ensured Flexi Loop nodes are not removed or added, or Flexi Loop nodes jumpered.



If you wish, you can configure IO-Link so that the Flexi Loop MSTR2 accessory also saves the node type. If you do this, the Flexi Loop MSTR2 accessory is able to prevent Flexi Loop nodes from being replaced with other types of nodes. In specific cases, this protection against tampering can be disabled.



Further topics

- ["Manipulation protection using the Flexi Loop MSTR accessory", page 52](#)

3.3 Device components

3.3.1 Flexi Loop node



Flexi Loop node	Description
 <p>EMSS, 5-pin</p> <p>Figure 9: FLN-EMSS0000105</p>	<p>The 5-pin Flexi Loop EMSS node is suitable for connecting dual-channel, equivalent switching, electro-mechanical safety switches, e.g., magnetic safety switches or emergency stop pushbuttons. The system tests the connected safety switches for cross- and short-circuits, and also for discrepancy and sequence errors.</p>
 <p>EMSS, 8-pin</p> <p>Figure 10: FLN-EMSS1100108</p>	<p>The 8-pin Flexi Loop EMSS node has one more non-safe input and one more non-safe output than the 5-pin Flexi Loop EMSS node. Control switches (e.g., pushbuttons) or actuators (e.g., lamps or locks) can be connected to them.</p>





Flexi Loop node	Description
<p>OSSD, 5-pin</p>  <p>Figure 11: FLN-OSSD1000105</p>	<p>The 5-pin Flexi Loop OSSD node is suitable for connecting safety sensors with a monitored semiconductor output (OSSD) (e.g., safety light curtains or RFID safety switches). It also has a non-safe input. Signal outputs of the sensors (e.g., for weak signals) can be connected to it. The system tests the connected safety sensors for discrepancy and sequence errors.</p>
<p>OSSD, 8-pin</p>  <p>Figure 12: FLN-OSSD1100108</p>	<p>The 8-pin Flexi Loop OSSD node has one more non-safe output than the 5-pin Flexi Loop OSSD node. Signal outputs of the sensors (e.g., for weak signals) or signal lamps (e.g., for reset required) can be connected to it.</p>

3.3.2 Flexi Loop terminator

Terminator	Description
<p>Terminator</p>  <p>Figure 13: FLT-TERM00001</p>	<p>The terminal is used to terminate the Flexi Loop safe series connection at the last Flexi Loop node. The terminator must be connected directly to the FL_OUT connection of the last Flexi Loop node (see "Connections of the Flexi Loop nodes", page 42).</p>

3.3.3 Flexi Loop accessories

Accessories	Description
<p>PWRI power supply accessory</p>  <p>Figure 14: FLA-PWRI00001</p>	<p>The power supply accessory is used to connect a +24 V power supply unit for galvanic separation of individual Flexi Loop sections and for overcurrent shutdown.</p>
<p>Flexi Loop MSTR1 accessory</p>  <p>Figure 15: FLA-MSTR00001</p>	<p>The Flexi Loop MSTR1 accessory connects a Flexi Loop safe series connection with a Flexi Classic safety controller. Two test pulse outputs (X) and two Flexi Classic module safe inputs (I) are required. The Flexi Loop MSTR1 accessory is also used for system monitoring when commissioning / during operation.</p>

Accessories	Description
<p data-bbox="459 216 646 268">Flexi Loop MSTR2 accessory</p>  <p data-bbox="459 464 619 516">Figure 16: FLA-MSTR0002</p>	<p data-bbox="708 216 1433 352">The MSTR2 Flexi Loop accessory connects a Flexi Loop safe series connection with a Flexi Classic safety controller. Two test pulse outputs (X) and two Flexi Classic module safe inputs (I) are required. The Flexi Loop MSTR2 accessory is also used for system monitoring when commissioning / during operation.</p> <p data-bbox="708 359 1437 443">The Flexi Loop MSTR2 accessory has one more non-safe input and one more non-safe output. The non-safe output also serves as an IO-Link interface.</p> <p data-bbox="708 449 1374 590">The non-safe input of the Flexi Loop MSTR2 accessory is used to control actuators at the non-safe outputs of the Flexi Loop nodes. The non-safe output of the Flexi Loop MSTR2 accessory is used to transmit switching signals at the non-safe inputs of the Flexi Loop nodes to a standard controller.</p> <p data-bbox="708 596 1422 648">The Flexi Loop MSTR2 accessory exchanges process data and service data with a PLC via the IO-Link interface.</p>
<p data-bbox="459 663 694 716">Flexi Loop DIAG accessory</p>  <p data-bbox="459 911 619 963">Figure 17: FLA-DIAG00001</p>	<p data-bbox="708 663 1374 695">The Flexi Loop DIAG accessory is used for the following purposes:</p> <ul data-bbox="708 701 1406 795" style="list-style-type: none"> • Status indicator during operation • System monitoring during a wiring test without a safety controller configured
<p data-bbox="459 984 651 1037">Flexi Loop adapter YCON1</p>  <p data-bbox="459 1232 619 1285">Figure 18: FLA-YCON00001</p>	<p data-bbox="708 984 1426 1037">The Flexi Loop YCON1 adapter is used to decouple the non-safe inputs and outputs of the Flexi Loop EMSS8 node.</p>
<p data-bbox="459 1306 651 1358">Flexi Loop adapter YCON2</p>  <p data-bbox="459 1554 619 1606">Figure 19: FLA-YCON00002</p>	<p data-bbox="708 1306 1426 1358">The Flexi Loop YCON2 adapter is used to decouple the non-safe inputs and outputs of the Flexi Loop OSSD8 node.</p>

3.3.4 Status indicators

LEDs of the Flexi Loop EMSS nodes

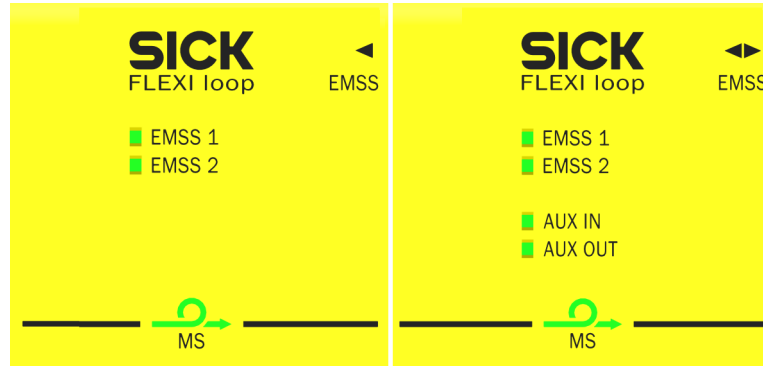

Figure 20: LEDs of the Flexi Loop EMSS nodes

Table 3: Indicators of the Flexi Loop EMSS nodes

Labeling	Color	Function
MS	Green/Red	Communication status / Flexi Loop node status ¹
EMSS 1 EMSS 2	Green	Switching contacts 1 and 2 respectively of the connected safety switch
AUX IN AUX OUT	Green	Non-safe input Non-safe output

¹ The only exception is the Flexi Loop YCON adapter

LEDs of the Flexi Loop OSSD nodes

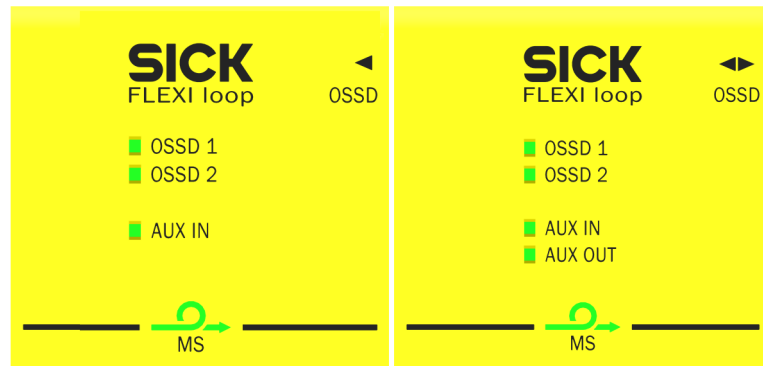

Figure 21: LEDs of the Flexi Loop OSSD nodes

Table 4: Indicators of the Flexi Loop OSSD nodes

Labeling	Color	Function
MS	Green/Red	Communication status / Flexi Loop node status ¹
OSSD 1 OSSD 2	Green	Connected OSSDs
AUX IN AUX OUT	Green	Non-safe input Non-safe output

¹ The only exception is the Flexi Loop YCON adapter

LEDs of the Flexi Loop PWRI accessory

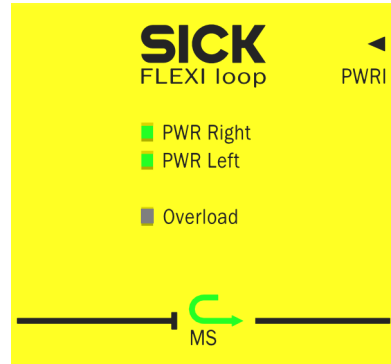

Figure 22: LEDs of the PWRI power supply accessory

Table 5: Indicators of the PWRI Flexi Loop accessory

Labeling	Color	Function
MS	Green/Red	Communication status / Flexi Loop node status ¹
PWR Right PWR Left	Green	Right / left input voltage of the PWRI power supply accessory
Overload	Red	Output overload

¹ The only exception is the Flexi Loop YCON adapter

LEDs for the Flexi Loop MSTR2 and DIAG accessories

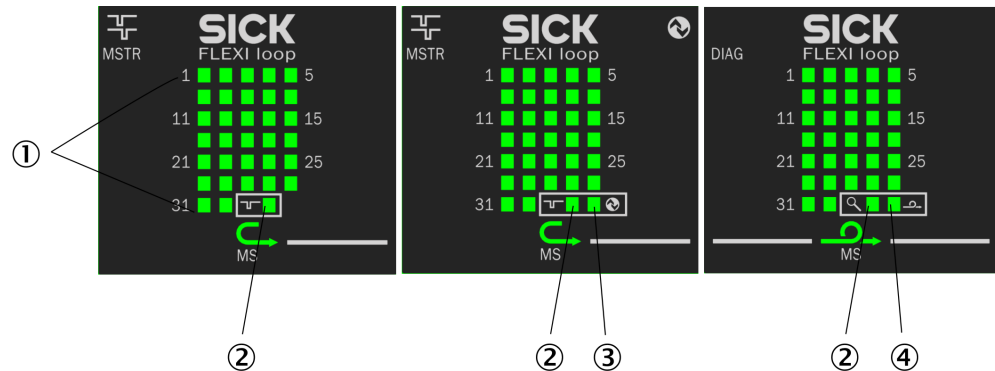

Figure 23: LEDs for the Flexi Loop MSTR2 and DIAG accessories

- ① Node LEDs 1 ... 32
- ② Operating mode LED
- ③ IO-Link LED
- ④ Loop integrity LED

Table 6: Indicators of the Flexi Loop MSTR and DIAG accessory

Labeling	Color	Function
Node LEDs 1 ... 32	Green	Status of the connected Flexi Loop nodes
Operating mode LED	Green	Status of the Flexi Loop MSTR and DIAG accessory
IO-Link LED	Green	Communication status to the IO-Link Master
Loop integrity LED	Green	Communication status within Flexi Loop

Further topics

["Indications of the LEDs", page 64](#)

4 Project planning

4.1 Total current



NOTICE

The Flexi Loop safe series connection permits a maximum total current of 4 A. An overcurrent can lead to a cable fire.

- ▶ Limit the total current in a section to 4 A.
- ▶ Use suitable fuse protection or current limiting devices to ensure that the input current does not exceed 4 A.

The magnitude of the total current is dependent on the following factors:

- number of nodes
- current consumption of the sensors and actuators connected

4.1.1 Permissible total current of a section

The permissible total current within a section is dependent upon the ambient temperature (see "Division into sections", page 27).

Table 7: Permissible total current within a section

Ambient temperature	Permissible total current ¹⁾
40 °C	4.0 A
55 °C	3.19 A

¹⁾ At UL/CSA applications only 3.2 A.

4.1.2 Permissible inrush current

Limit the inrush current flowing through the PWRI connection of the PWRI power supply accessory to less than 40 A. Failure to do this may cause the short-circuit limiter associated with the power supply accessory to trip.

Possible solutions:

- Use a suitable current-limited power supply unit.
- Increase the electrical resistance between the power supply unit and the first Flexi Loop node downstream of the PWRI power supply accessory to 0.75 Ω (e.g., by reducing the wire cross-section or increasing the length of the cable).

Tip: Minimum length of the cable between power supply unit and Flexi Loop node = wire cross-section × 25 m/mm² (e.g., 8.5 m for 0.34 mm²).

4.1.3 Other limits

It is possible to connect sensors with a maximum current consumption of 3.9 A to the OSSD device connection on the FLN-OSSD1000105 Flexi Loop node.

A maximum current of 2 A is allowed to flow through the 8-pin M12 female connectors on the Flexi Loop nodes (AUX_OUT + VDC). ²⁾

It is possible to connect loads with a maximum current consumption of 0.5 A in relation to ground to the non-safe outputs (AUX_OUT) on the FLN-OSSD1100108 and FLN-EMSS1100108 Flexi Loop nodes.

²⁾ Make sure the current drawn via VDC and AUX_OUT flows back via the GND pin.

A maximum total current of 2 A is allowed to flow through the VDC pins (1 and 2) of the 8-pin M12 female connector on the MSTR Flexi Loop accessory. Use both power supply pins (1 and 2) and both GND pins (5 and 6) on the MSTR Flexi Loop accessory for the power supply.

A maximum current of 2 A is permitted to flow through the pins of each of the Flexi Loop YCON1 and YCON2 adapters.

4.1.4 Connection facilities



NOTICE

If the connection cables for the Flexi Loop nodes are disconnected, e.g. to power them directly using a separate voltage supply unit, then several voltage supply units are connected in parallel. In this instance, the loss of a GND connection can lead to overcurrent and cable fires.

- ▶ Never disconnect the connection cables of the Flexi Loop nodes.

4.1.4.1 Connection to the voltage source of the safety controller

Important information



NOTICE

The Flexi Loop safe series connection permits a maximum total current of 4 A. An overcurrent can lead to a cable fire.

- ▶ Limit the total current in a section to 4 A.
- ▶ Use suitable fuse protection or current limiting devices to ensure that the input current does not exceed 4 A.

Connection to the voltage source of the programmable SICK safety controller

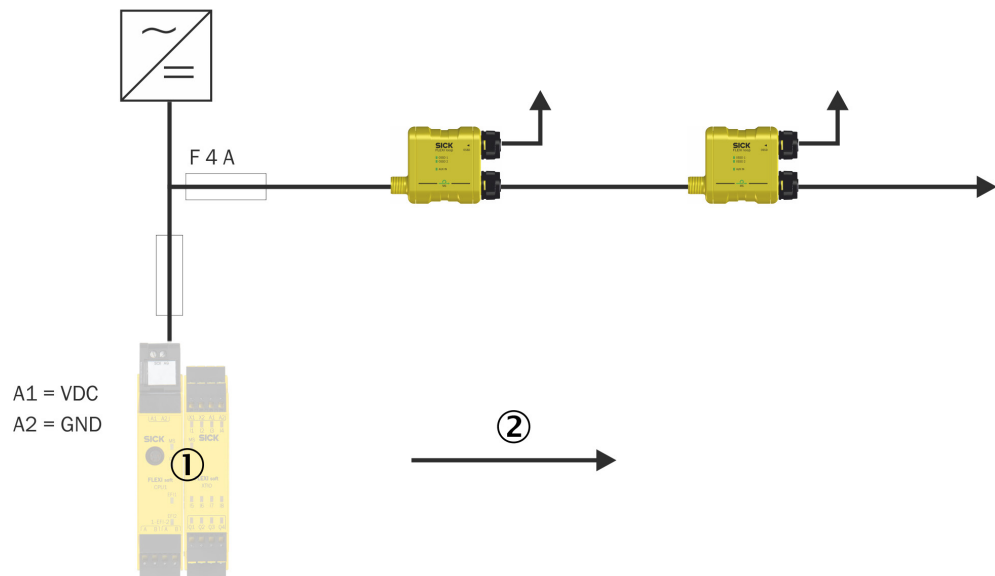

Figure 24: Direct connection to the voltage source of the programmable SICK safety controller

- ① Programmable SICK safety controller: Flexi Soft or Flexi Compact
- ② Current flow

Connection to the voltage source of the Flexi Classic safety controller

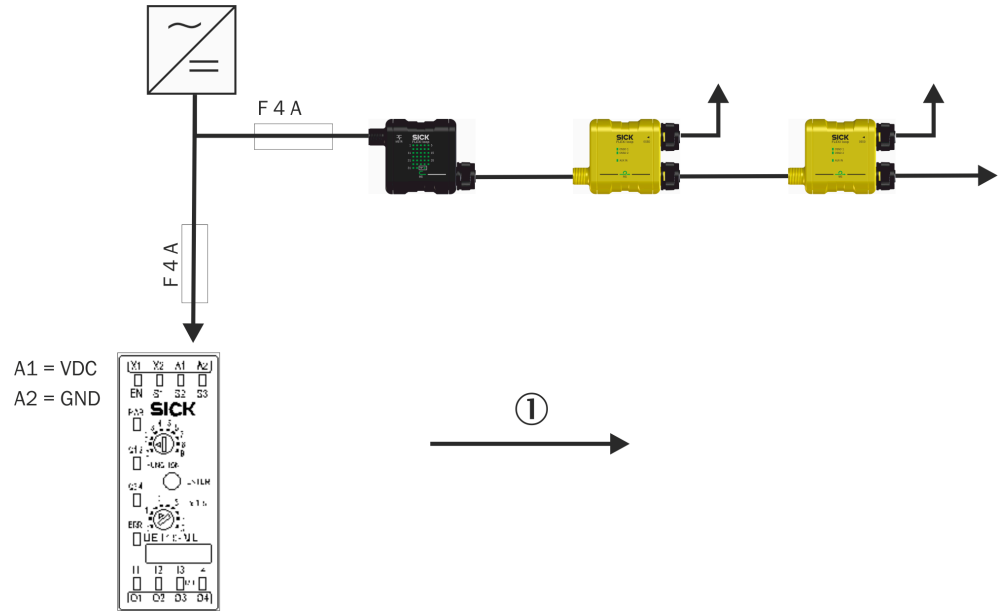

Figure 25: Direct connection to the voltage source of the Flexi Classic safety controller

① Power flow

4.1.4.2 Connection via the PWRI power supply accessory (recommended)

If you power a Flexi Loop safe series connection using the PWRI energy infed accessory, this monitors the current and shuts down in the event of overcurrent. The supply voltage is also monitored within each section.

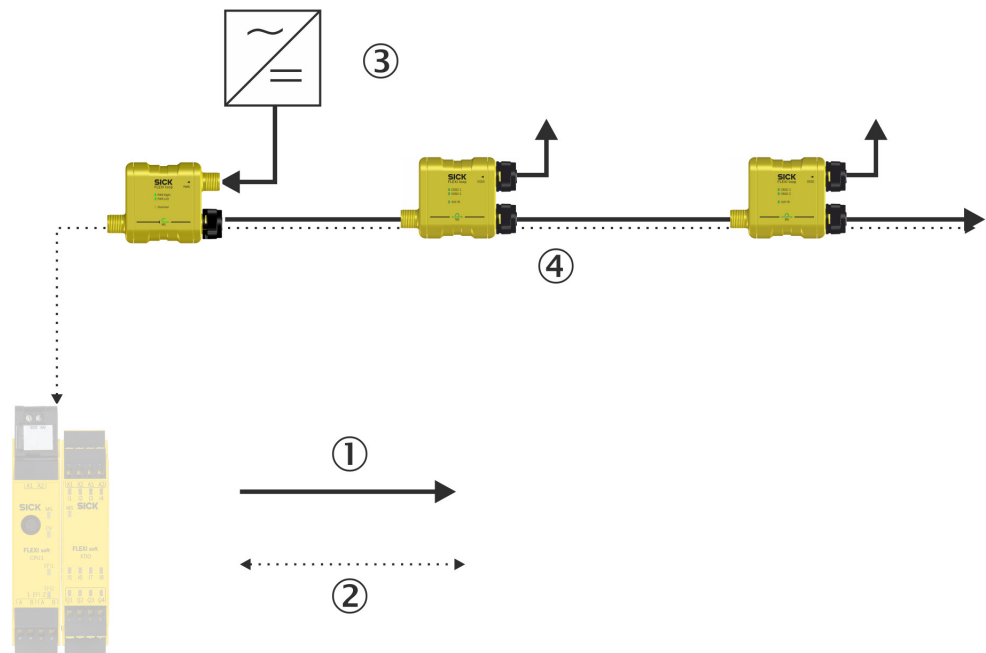

Figure 26: Connection via the PWRI power supply accessory for the programmable SICK Flexi Soft or Flexi Compact safety controller

① Current flow
② Data flow
③ Power supply unit

④ Max. 4 A

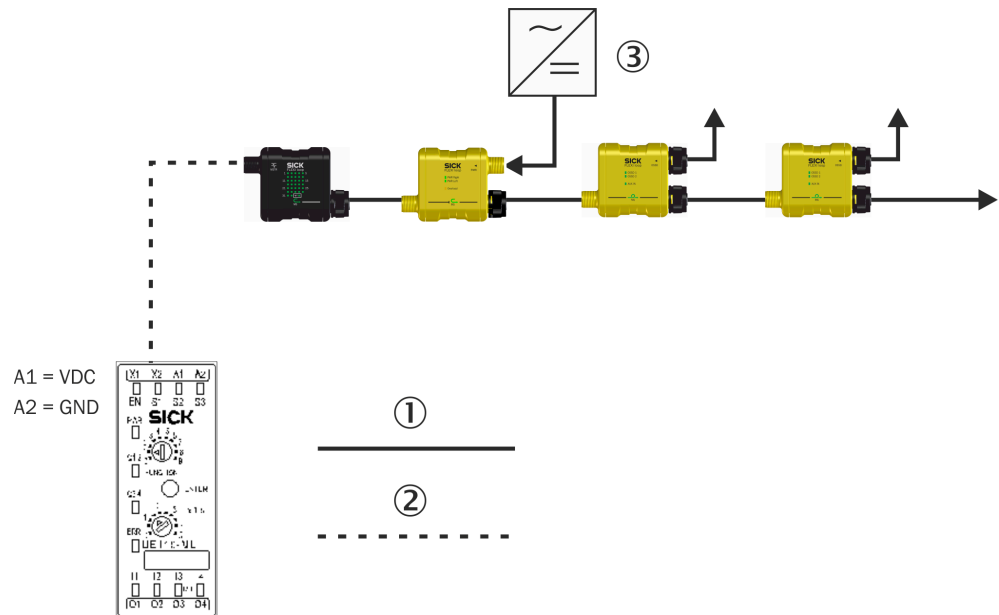

Figure 27: Connection via the PWRI power supply accessory for the Flexi Classic safety controller

- ① Flexi Loop power flow
- ② MSTR power supply
- ③ Power supply

4.1.5 Division into sections

If higher currents are required, the Flexi Loop safe series connection can be subdivided into individual sections (see "Subdivision into a segment, section, and line", page 12).

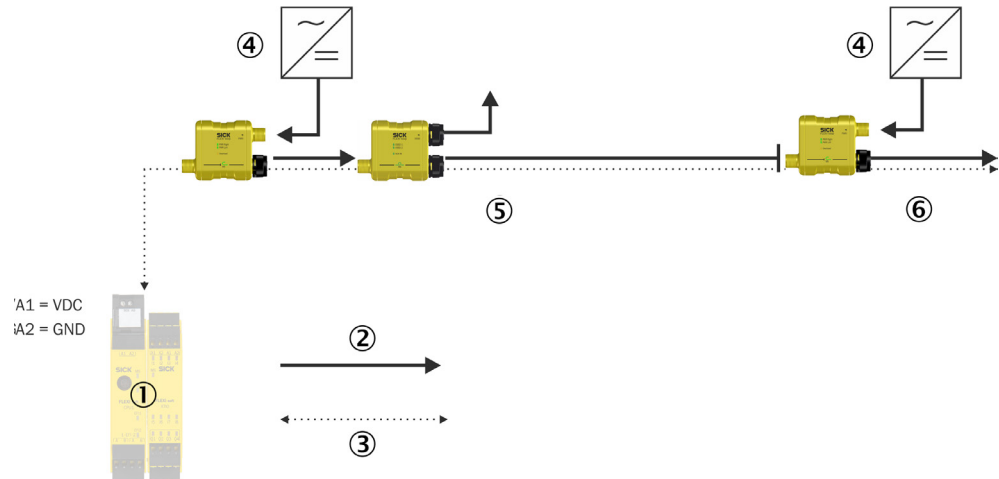

Figure 28: Division into sections

- ① Programmable SICK safety controller: Flexi Soft or Flexi Compact
- ② Power flow
- ③ Data flow
- ④ Power supplies
- ⑤ Section 1 max. 4 A
- ⑥ Section 2 max. 4 A

The PWRI power supply accessory monitors the current in the individual Flexi Loop sections and shuts down in case of overcurrent. In addition the operating voltage in each section is monitored.

The voltage supply of the following Flexi Loop nodes and the connected sensor is electrically isolated from the upstream Flexi Loop nodes by the power supply accessory.

4.2 Voltage drop via cables, Flexi Loop nodes and Flexi Loop accessories

Voltage drop

The VDC voltage has to be in the range of 16.8 ... 30 V DC at each input of a Flexi Loop node and a Flexi Loop accessory.

The voltage drop depends on the following factors:

- Number of Flexi Loop nodes (own current consumption)
- Current consumption of the connected sensors and actuators
- Length of the cables
- Cross section of the conductors
- Ambient temperature

Measures to avoid a voltage drop

If the voltage drop over a Flexi Loop section or a Flexi Loop section becomes too large, i.e. if the input voltage at a node is too low, this can be corrected by one of the following means.

- Increase the wire cross-section
- Shorten the cables, if possible
- Install the PWRI power supply accessory



NOTE

The configuration software supports an option for the offline calculation or online measuring of the voltage drop (see the “Flexi Loop in the Flexi Soft Designer” operating instructions, part no. 8014522, or “Flexi Loop in the Safety Designer, part no. 8018174).

4.2.1 Examples for the voltage drop

In the following examples an input voltage of 24 V DC is assumed.

Number of nodes

The first examples show how the voltage drop behaves in relation to the number of Flexi Loop nodes. The examples assume that there are no devices connected to the Flexi Loop nodes, instead that power only flows due to internal consumption of the nodes (e.g. on exclusive operation with Flexi Loop nodes of type FLN-EMSS0000105).

The following table shows that although the voltage reduces at the individual Flexi Loop nodes due to the voltage drop, it is still high enough at the 10th Flexi Loop node.

Table 8: Example voltage drop on 10 Flexi Loop nodes

Segment	Wire cross-section [mm ²]	Cable length [m]	Voltage VDC [V]	Current consumption of connected devices [A]
1	0.34	15.00	23.10	0.00
2	0.34	15.00	22.29	0.00
...				
9	0.34	15.00	18.98	0.00
10	0.34	15.00	18.85	0.00

However, if 15 Flexi Loop nodes are used in the same conditions, the input voltage drops below the permissible value from the 7th Flexi Loop node.

Table 9: Example voltage drop on 15 Flexi Loop nodes

Segment	Wire cross-section [mm ²]	Cable length [m]	Voltage VDC [V]	Current consumption of connected devices [A]
1	0.34	15.00	22.68	0.00
2	0.34	15.00	21.44	0.00
...				
6	0.34	15.00	17.33	0.00
7	0.34	15.00	16.52	0.00
...				
15	0.34	15.00	13.08	0.00

Solution example with PWRI power supply accessory

By using a PWRI power supply accessory after the 11th Flexi Loop node, the input voltage is adequate at all Flexi Loop nodes.

Table 10: Example voltage drop on 15 Flexi Loop nodes with PWRI

Segment	Wire cross-section [mm ²]	Cable length [m]	Voltage VDC [V]	Current consumption of connected devices [A]
1	0.34	15.00	23.02	0.00
2	0.34	15.00	22.12	0.00
...				
11	0.34	15.00	17.86	0.00
FLA-PWRI				
1	0.34	15.00	23.02	0.00
...				
4	0.34	15.00	20.58	0.00

Solution example with increased wire cross-section

Using a wire cross-section of 0.75 mm² will ensure that a sufficient input voltage is available even at the 15th Flexi Loop node.

Table 11: Example voltage drop on 15 Flexi Loop nodes with wire cross-section 0.75 mm²

Segment	Wire cross-section [mm ²]	Cable length [m]	Voltage VDC [V]	Current consumption of connected devices [A]
1	0.75	15.00	23.38	0.00
2	0.75	15.00	22.80	0.00
...				
14	0.75	15.00	18.96	0.00
15	0.75	15.00	18.89	0.00

Devices with current consumption

If devices with a current consumption are connected to the Flexi Loop node (in the example with 0.5 A and with 1.5 A), the input voltage drops below the permissible value from the 2nd Flexi Loop node.

Table 12: Example voltage drop due to current consumption of connected devices

Segment	Wire cross-section [mm ²]	Cable length [m]	Voltage VDC [V]	Current consumption of connected devices [A]
1	0.34	15.00	20.00	0.50
2	0.34	15.00	16.86	1.50
3	0.34	15.00	16.14	0.00
...				
10	0.34	15.00	13.42	0.00

Solution example with PWRI power supply accessory

By using a PWRI power supply accessory after the 5th Flexi Loop node, the input voltage is adequate at all 10 Flexi Loop nodes.

Table 13: Example voltage drop on 10 Flexi Loop nodes with PWRI

Segment	Wire cross-section [mm ²]	Cable length [m]	Voltage VDC [V]	Current consumption of connected devices [A]
1	0.34	15.00	23.02	0.50
2	0.34	15.00	22.12	1.50
...				
5	0.34	15.00	17.07	0.00
FLA-PWRI				
1	0.34	15.00	23.97	0.00
...				
5	0.34	15.00	22.93	0.00

Solution example with increased wire cross-section

Using a wire cross-section of 0.75 mm² will ensure that a sufficient input voltage is available even at the 10th Flexi Loop node.

Table 14: Example voltage drop at 10 Flexi Loop nodes with wire cross-section 0.75 mm²

Segment	Wire cross-section [mm ²]	Cable length [m]	VoltageVDC [V]	Current consumption of connected devices [A]
1	0.75	15.00	23.84	0.50
2	0.75	15.00	22.37	1.50
...				
9	0.75	15.00	20.82	0.00
10	0.75	15.00	20.76	0.00

4.3 Supply of OSSD devices



NOTICE

If multiple power supply units in a Flexi Loop section are connected in parallel, the loss of the GND connection can lead to overcurrent and cable fires.

- ▶ Connected OSSD devices should always be supplied with power via the OSSD female connector of the Flexi Loop node FLN-OSSD1000105 or FLN-OSSD1100108.
- ▶ OSSD devices must always be connected to the same voltage supply as the Flexi Loop node to which they are connected.
- ▶ Always use the power supply accessory to connect additional power supply units.
- ▶ **Never** use a separate power supply unit to supply power directly to a connected OSSD device.

4.4 Integration in the electrical control system

4.4.1 Implementation of reset

4.4.1.1 Reset using the programmable SICK safety controller

Important information



WARNING

Unexpected machine start-up by using the same inputs

If this is not observed, a system or machine may start unexpectedly.

- ▶ Do not connect the restart command device input to the same safe series connection as the reset button input.

Procedure

The reset function must be implemented in the logic editor of the configuration software (see the “Flexi Loop in the Flexi Soft Designer” operating instructions, part no. 8014522, or “Flexi Loop in the Safety Designer, part no. 8018174).

1. Connect one or more reset buttons to the non-safe inputs (AUX_IN) of the Flexi Loop nodes FLN-EMSS1100108 or FLN-OSSD1100108.
2. If necessary, connect one or more signal lamps to the non-safe outputs (AUX_OUT) of the Flexi Loop nodes FLN-EMSS1100108 or FLN-OSSD1100108.

3. If you use other non-safe inputs (AUX_IN) of the Flexi Loop nodes for purposes other than resetting, ensure that they do not meet any reset condition ³⁾.

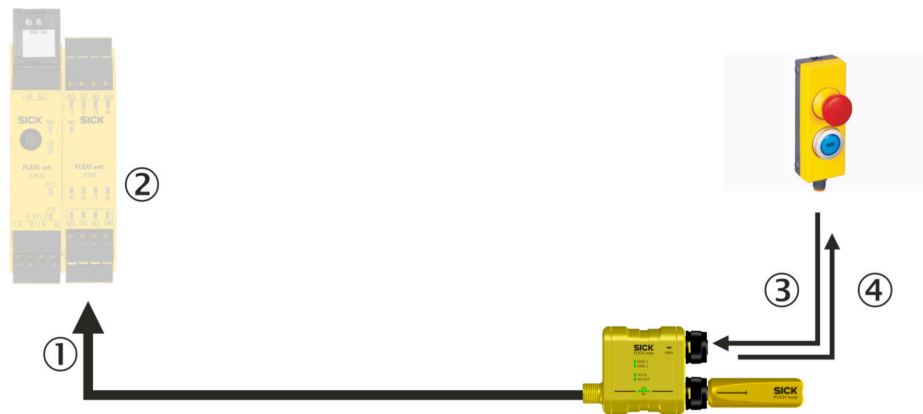

Figure 29: Reset using the programmable SICK safety controller

- ① Safe cut-off path
- ② Programmable SICK safety controller: Flexi Soft or Flexi Compact
- ③ Reset signal
- ④ Activation of lamps

4.4.1.2 Reset using the Flexi Classic safety controller

Important information



WARNING

Hazard due to unexpected starting of the machine

- Use an additional control switch for the purpose of restarting the machine downstream of and external to the system configuration consisting of Flexi Loop and Flexi Classic safety controller.



WARNING

Hazard due to unexpected starting of the machine

If other non-safe inputs (AUX_IN) of the Flexi Loop nodes are used for purposes other than a reset, they must not fulfill a reset condition.

- For example, mask the nodes using the IO link so that the AUX_IN TO MSTR AUX_OUT parameter is switched off (see ["Configuration of the Flexi Loop nodes", page 55](#))

Prerequisites

- If you connect reset buttons to the Flexi Loop safe series connection and wish to integrate them into a Flexi Classic safety controller, you must use the Flexi Loop MSTR2 accessory.
- Use its standard I/O functions with factory settings without data communication via IO-Link (see ["Operating principle of Flexi Loop on a Flexi Classic", page 15](#)).

³⁾ Reset is achieved by pressing and releasing the reset button. This action generates a high-active pulse lasting at least 100 ms but no longer than 30 s

Procedure

- ▶ Connect one or more reset buttons to the non-safe inputs of the Flexi Loop nodes FLN-EMSS1100108 or FLN-OSSD1100108. All of the non-safe inputs (AUX_IN) influence the Flexi Loop MSTR2 accessory non-safe output (AUX_OUT).
- ▶ Integrate this signal into the reset function of the Flexi Classic safety controller. Follow the instructions for resets and external device monitoring in the “Flexi Classic Modular Safety Controller” operating instructions, part no. 8011737.

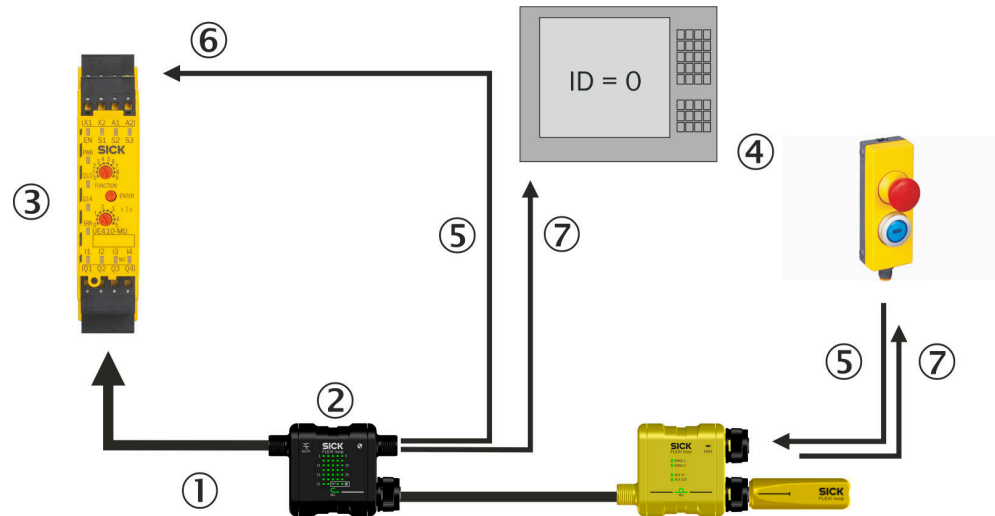

Figure 30: Reset using the Flexi Classic safety controller

- ① Safe cut-off path
- ② Flexi Loop MSTR2 accessory
- ③ Flexi Classic safety controller
- ④ Application (e.g., in a PLC)
- ⑤ Reset signal
- ⑥ Reset using Flexi Classic
- ⑦ Activation of lamps

Complementary information

Signal propagation times via Flexi Loop communication always result in longer pulse durations during signal transmission. An input signal from the non-safe input (AUX_IN) of a Flexi Loop node therefore has a longer pulse duration at the output (AUX_OUT) of the Flexi Loop MSTR2 accessory.

4.4.2 Implementation of a safety locking device

4.4.2.1 Connection to EMSS node

The safety switching contacts of a spring-locked safety locking device are connected to the EMSS connections of the Flexi Loop node. Guard position monitoring for the protective device and the interlocking device must be implemented with the same switching element. If output monitoring of the Flexi Loop node is deactivated, the actuator signal for the lock can be connected at the AUX_IN input. The interlocking device for the safety locking device is connected at the AUX_OUT output.

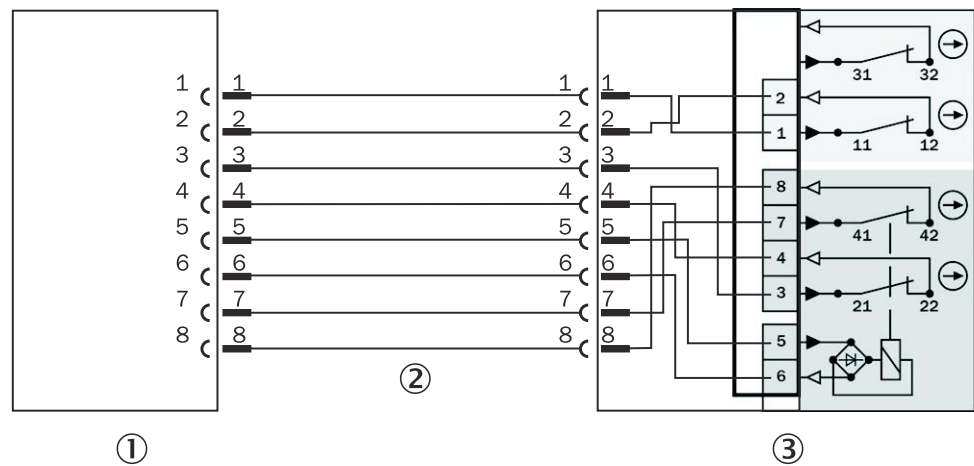

Figure 31: Connection of a safety locking device to the EMSS node

- ① EMSS node
- ② Connecting cable M12, 8-pin, male/female connector
- ③ Safety locking device i10 Lock, i10-M0454

Table 15: Pin assignment safety locking device to EMSS node

8-pin EMSS pin (female connector)	Signal	i10 lock pin, i10-M0454 (male connector)
1	VDC	1
2	AUX_IN	2
3	EMSS1_A	3
4	EMSS1_B	4
5	AUX_OUT	5
6	GND	6
7	EMSS2_A	7
8	EMSS2_B	8

4.4.2.2 Lock using the programmable SICK safety controller

The lock function must be implemented in the logic editor of the configuration software (see the “Flexi Loop in the Flexi Soft Designer” operating instructions, part no. 8014522, or “Flexi Loop in the Safety Designer, part no. 8018174).

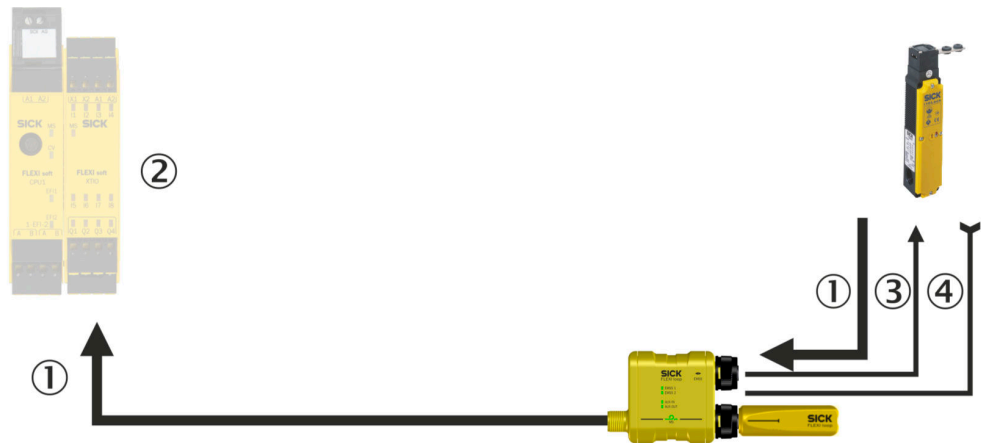

Figure 32: Lock using the programmable SICK safety controller

- ① Safe cut-off path (guard position monitoring of the protective device and the interlocking device)
- ② Programmable SICK safety controller: Flexi Soft or Flexi Compact
- ③ Signal for interlocking device
- ④ Actuator status signal

4.4.2.3 Lock using the Flexi Classic safety controller

Prerequisites

- If you connect locks to the Flexi Loop safe series connection and wish to integrate them into a Flexi Classic safety controller, you must use the Flexi Loop MSTR2 accessory.
- Use its standard I/O functions with factory settings without data communication via IO-Link (see "Operating principle of Flexi Loop on a Flexi Classic", page 15).

Procedure

- ▶ Connect the signal for interlocking your application to the AUX_IN non-safe input of the Flexi Loop MSTR2 accessory. .
- ✓ The safe series connection forwards the signal to the non-safe outputs of the Flexi Loop nodes, where it deactivates the lock's connected interlocking device.

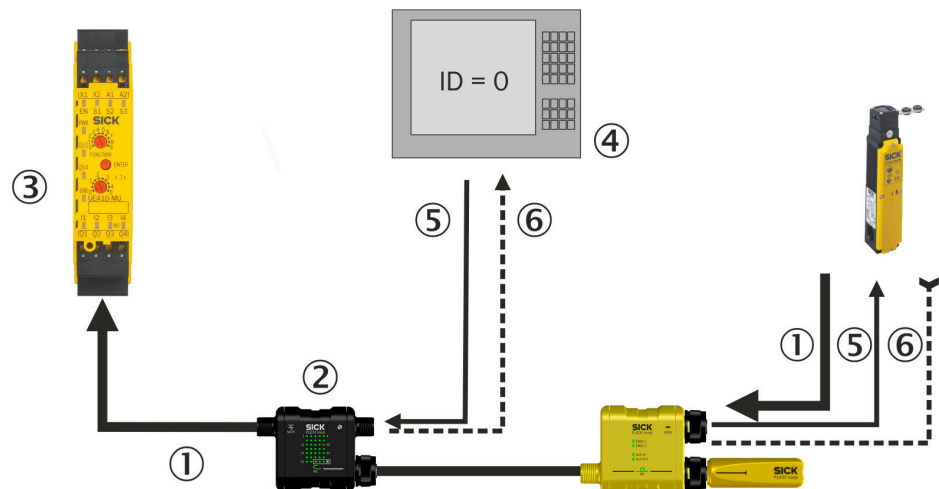

Figure 33: Lock using the Flexi Classic safety controller

- ① Safe cut-off path (guard position monitoring of the protective device and the interlocking device)

- ② Flexi Loop MSTR2 accessory
- ③ Flexi Classic safety controller
- ④ Lock application (e.g., in a PLC)
- ⑤ Signal for interlocking device
- ⑥ Optional: actuator status signal

Complementary information

The AUX_IN non-safe input of the Flexi Loop MSTR2 accessory is factory-set to affect all AUX_OUT non-safe outputs of the Flexi Loop nodes. If you wish to use AUX_OUT non-safe outputs of individual Flexi Loop nodes for purposes other than to connect a lock, then switch off the **AUX_OUT from MSTR AUX_IN** parameter for this Flexi Loop node via IO-Link (see ["Configuration of the Flexi Loop nodes"](#), page 55).



NOTE

For all FLN-EMSS1100108 Flexi Loop nodes with a connected lock, leave the non-safe AUX_IN input unassigned or connect it to GND ⑥. The factory-activated output monitoring for all Flexi Loop nodes will otherwise interfere with the switching behavior of the non-safe AUX_OUT outputs.

Actuator status signal

You can connect the status signals from the actuator of a lock to AUX_IN of the Flexi Loop EMSS8 node and forward them to your application.

Use IO-Link to deactivate output monitoring for all Flexi Loop nodes with a connected lock (see ["Configuration of the Flexi Loop nodes"](#), page 55).

Use IO-Link to select the link logic of the status signals at the non-safe output of the Flexi Loop MSTR2 accessory with the **MSTR AUX_OUT LOGIC** parameter (see ["Configuration of the Flexi Loop string"](#), page 57).

Connect the signal of the actuator to the non-safe input AUX_IN of the Flexi Loop nodes. The safe series connection forwards the signal to the non-safe output of the Flexi Loop MSTR2 accessory. Connect this signal with your application ⑥.

4.5 Testing plan

The manufacturer of the machine and the operating entity must define all required thorough checks. The definition must be based on the application conditions and the risk assessment and must be documented in a traceable manner.

The following tests must be planned:

- A thorough check must be carried out during commissioning and following modifications.
- The regular tests of the device must fulfill certain minimum requirements.

5 Mounting

5.1 Mounting in a cable channel

You can mount the Flexi Loop nodes in a ≥ 40 mm-wide cable channel.

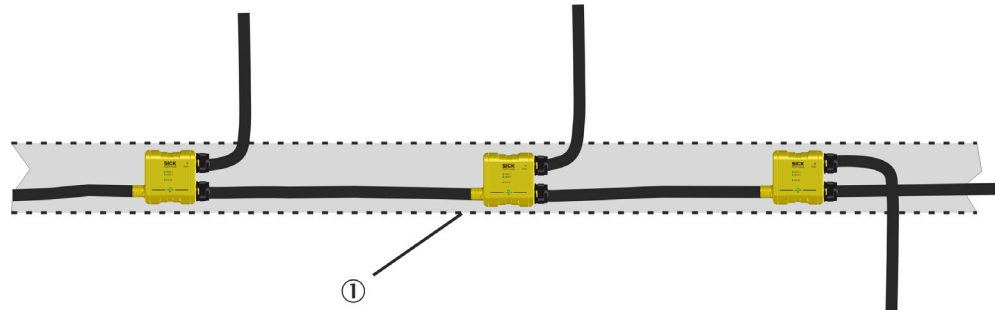

Figure 34: Mounting in a cable channel

① Cable channel

5.2 Mounting with cable tie

The Flexi Loop nodes have a slot at the top and bottom. These slots enable them to be secured with a cable tie.

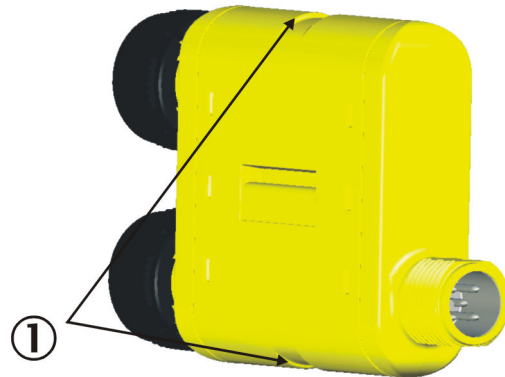

Figure 35: Mounting with cable tie

① Slot for cable tie

5.3 Mounting the C-Fix bracket and Flexi Loop nodes

Procedure

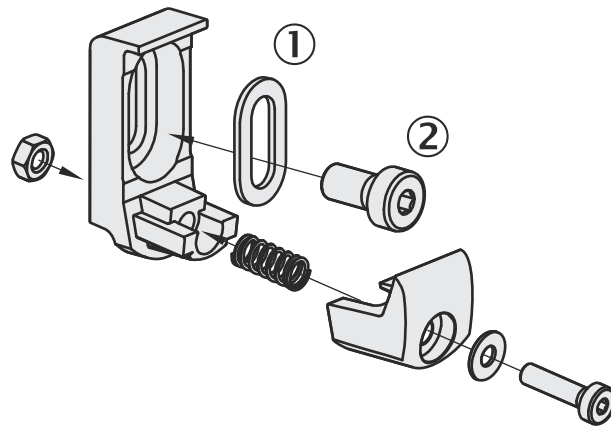

Figure 36: C-Fix bracket

- ① Washer
- ② Fixing screws M5 (not included)

1. Fasten the C-Fix bracket with washer and M5 fixing screw to a flat surface. Tighten the M5 screw with a torque of approx. 3 Nm.



Figure 37: Mounting the Flexi Loop node using a C-Fix bracket

2. Insert the Flexi Loop node into the C-Fix bracket and gently press it downward (②).
3. Rotate the Flexi Loop node towards the back (③) until the C-Fix bracket engages with the slot in the Flexi Loop node housing (④).
4. To secure the Flexi Loop node, tighten the M3 screw of the C-Fix bracket with a torque of approx. 1.5 Nm (⑤).

Complementary information

The C-Fix brackets are suitable for mounting the Flexi Loop nodes on mounting profiles with T-slots.

6 Electrical installation

6.1 Notes on cULus

If the product is being used in accordance with ANSI / UL 508 or CSA 22.2 No. 142, the following conditions must also be met:

- Protection of the device's 24-volt voltage supply with a fuse with a maximum DC voltage of 4A and a minimum of 30 V in accordance with UL 248
- Wiring with UL listed connecting cables (CYJV/7), min. 30 V DC, 4 A, 55 °C



NOTE

The safety functions have not be tested by UL. Authorization is in accordance with UL 508, general applications.

6.2 Connecting

Important information



NOTE

- The Flexi Loop safe series connection complies with the Radio Safety Requirements (EMC) for the industrial sector (Radio Safety Class A). It may cause radio interference if used in a residential area.

Prerequisites

- Dangerous condition of the machine is and remains off during the electrical installation.
- Carry out the electrical installation work in conformity with EN 60204-1.
- The device voltage supply must be capable of buffering brief power failures of 20 ms, for example, as specified in EN 60204-1.
- The voltage supply and all connected signals must meet the requirements for extra-low voltages with safe separation (SELV/PELV) as specified in EN 60664.
- All connected safety sensors and actuators as well as wiring and routing must comply with the required characteristic safety values.
- When exchanging a Flexi Loop node, the correct pin assignment must be ensured, for instance with marks or suitable routing.

6.2.1 Connection to programmable SICK safety controller

Connection to programmable SICK safety controller

The Flexi Loop safe series connection is connected to one test output (X) and two safe inputs (I) of an I/O module. The terminal pin assignments are listed in the operating instructions of the safety controller. Use 5-pin cables with M12 female connector and open cable ends to connect the safe series connection (see ["Pre-assembled cables"](#), page 90).

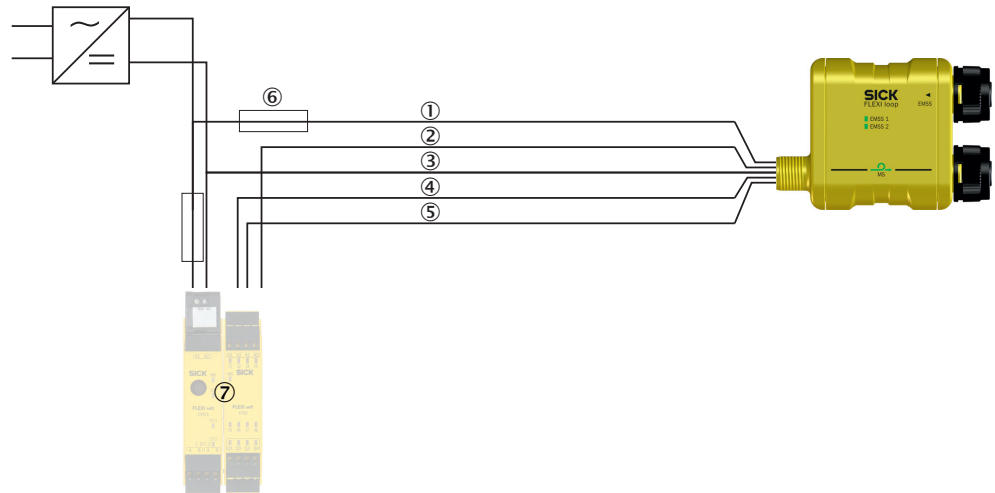

Figure 38: Connection to programmable SICK safety controller

- ① VDC
- ② DATA_OUT
- ③ GND
- ④ SAFE_OUT
- ⑤ DATA_IN
- ⑥ Fuse with 4 A
- ⑦ Programmable SICK safety controller: Flexi Soft or Flexi Compact

Connection example with Flexi Soft



NOTE

The output for the DATA_OUT signal and the input for the SAFE_IN signal must match on the safety controller.

- When X1 is used, I1 must be used.
- When X2 is used, I2 must be used.
- Etc.

You can select any input for the DATA_IN data return path.

Table 16: Connection example with Flexi Soft

Flexi Loop pin	Flexi Loop signal	FX3-XTDI terminal	Flexi Soft signal
1	VDC	A1	VDC
2	DATA_OUT	I2	DATA_IN
3	GND	A2	GND
4	SAFE_OUT	I1	SAFE_IN
5	DATA_IN	X1	DATA_OUT

Further topics

- ["Connection to the voltage source of the safety controller", page 25](#)

6.2.2 Connection to Flexi Classic

Connection to Flexi Classic

Connect the Flexi Loop MSTR accessory to two test outputs (X) and two safe inputs (I) of the safety controller. The terminal pin assignments are listed in the “Flexi Classic Modular Safety Controller” operating instructions. Use 8-pin cables with M12 female connector and open cable ends to connect the safe series connection (see "Pre-assembled cables", page 90).



NOTE

Use both supply voltage pins (1 and 2) and both GND pins (5 and 6) of the Flexi Loop MSTR accessory as the power supply.

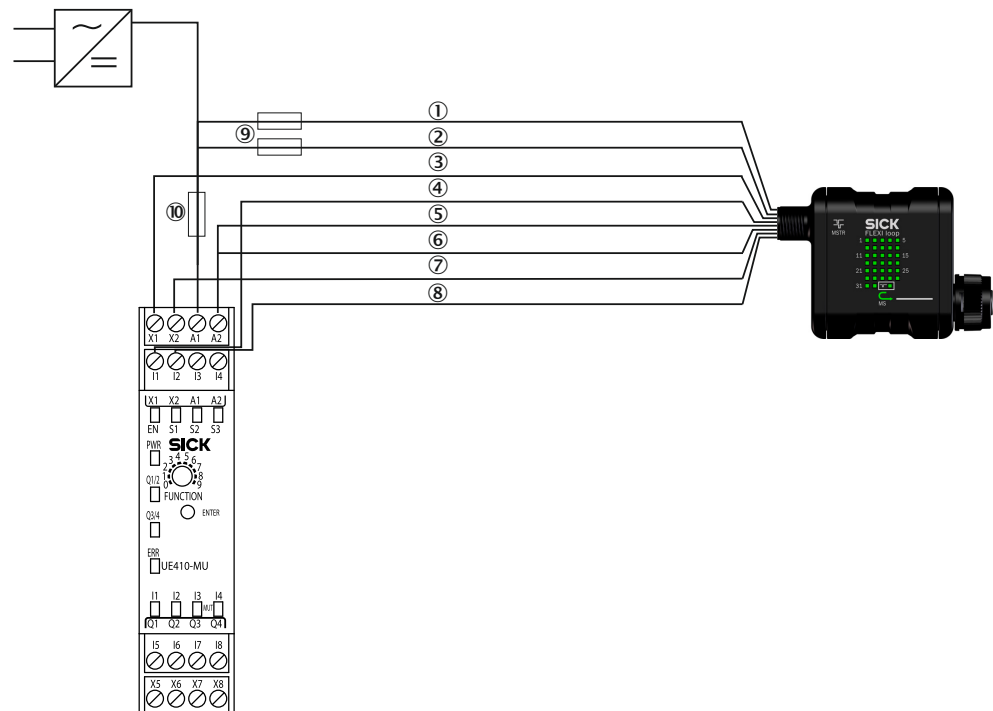

Figure 39: Connection example with Flexi Classic

- ① VDC
- ② VDC
- ③ FC_A1
- ④ FC_A2
- ⑤ GND
- ⑥ GND
- ⑦ FC_B1
- ⑧ FC_B2
- ⑨ 2 fuses with 2 A
- ⑩ Fuse with 4 A

Connection example with Flexi Classic

Table 17: Connection example with Flexi Classic

MSTR Flexi Loop accessory pin	Signal	Flexi Classic terminal (UE410-MU)
1 and 2	VDC	A1
3	FC_A1	X1

MSTR Flexi Loop accessory pin	Signal	Flexi Classic terminal (UE410-MU)
4	FC_A2	I1
5 and 6	GND	A2
7	FC_B1	X2
8	FC_B2	I2

Further topics

- ["Connection to the voltage source of the safety controller", page 25](#)

6.2.3 Connections of the Flexi Loop nodes



Figure 40: Connections of the Flexi Loop nodes

- ① FL_IN (male connector)
- ② FL_OUT (female connector)

FL_IN 5-pin

The pin assignment is required to connect the first Flexi Loop node to a programmable SICK safety controller.

Table 18: Pin assignment FL_IN (male connector)

Male connector	Pin	Signal	Meaning	Color ¹⁾
	1	VDC	24 V supply voltage	Brown
	2	DATA_OUT	Output to the safety controller input In + 1	White
	3	GND	GND supply voltage	Blue
	4	SAFE_OUT	Safe cut-off signal Output to the safety controller input In	Black
	5	DATA_IN	Input from the safety controller output Xn	Gray

¹⁾ The stated colors apply on the usage of pre-assembled cables (should be checked).

6.2.4 Connecting the Flexi Loop nodes

The Flexi Loop nodes are connected to one another with 1:1 cables (male connector / female connector) via FL_OUT and FL_IN.



NOTE

- ▶ Only use cables with straight male or female connectors.
- ▶ **Never** connect two Flexi Loop nodes directly by plugging the male connector of one into the female connector of the other.

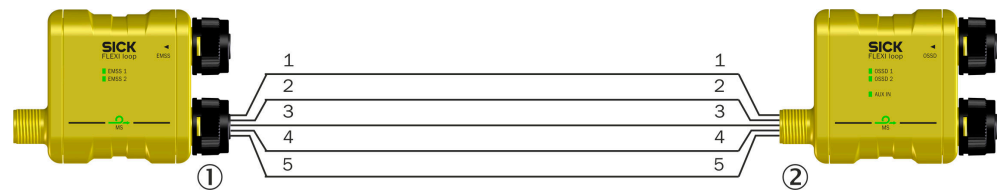

Figure 41: Connecting the Flexi Loop nodes

- ① FL_OUT (female connector)
- ② FL_IN (male connector)



NOTICE

If the connection cables for the Flexi Loop nodes are disconnected, e.g. to power them directly using a separate voltage supply unit, then several voltage supply units are connected in parallel. In this instance, the loss of a GND connection can lead to overcurrent and cable fires.

- ▶ Never disconnect the connection cables of the Flexi Loop nodes.

6.2.5 Connections of the EMSS Flexi Loop node



Figure 42: Connections of the EMSS Flexi Loop node

- ① EMSS (female connector)

EMSS 5-pin

Table 19: Pin assignment EMSS 5-pin (female connector)

Female connector	Pin	Signal	Meaning	Color ¹⁾
	1	EMSS1_A	Switching contact 1, connection A	Brown
	2	EMSS1_B	Switching contact 1, connection B	White
	3	EMSS2_A	Switching contact 2, connection A ²⁾	Blue
	4	EMSS2_B	Switching contact 2, connection B	Black
	5	EMSS2_A	Switching contact 2, connection A ²⁾	Gray

¹⁾ The stated colors apply on the usage of pre-assembled cables (should be checked).

²⁾ You can either use Pin 3 or Pin 5 as connection A of switching contact 2.

EMSS 8-pin

Table 20: Pin assignment EMSS 8-pin (female connector)

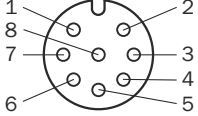
Female connector	Pin	Signal	Meaning	Color ¹⁾
	1	VDC	24 V supply voltage	White
	2	AUX_IN	Non-safe input	Brown
	3	EMSS1_A	Switching contact 1, connection A	Green
	4	EMSS1_B	Switching contact 1, connection B	Yellow
	5	AUX_OUT	Non-safe output	Gray
	6	GND	GND supply voltage	Pink
	7	EMSS2_A	Switching contact 2, connection A	Blue
	8	EMSS2_B	Switching contact 2, connection B	Red

¹⁾ The stated colors apply on the usage of pre-assembled cables (should be checked).

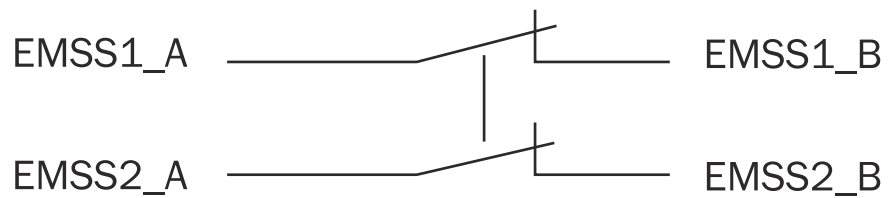

Figure 43: Connection sketch dual-channel equivalent switch

An example application for the connection of a lock: [see "Implementation of a safety locking device", page 33.](#)

6.2.6 Connections of the OSSD Flexi Loop node

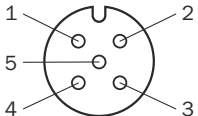

Figure 44: Connections of the OSSD Flexi Loop node

① OSSD (female connector)

OSSD 5-pin

Table 21: Pin assignment OSSD 5-pin (female connector)

Female connector	Pin	Signal	Meaning	Color ¹⁾
	1	VDC	24 V supply voltage for safety device	Brown
	2	OSSD1	Input OSSD1	White
	3	GND	GND supply voltage for safety device	Blue
	4	OSSD2	Input OSSD2	Black
	5	AUX_IN	Non-safe input	Gray

¹⁾ The stated colors apply on the usage of pre-assembled cables (should be checked).

OSSD 8-pin

Table 22: Pin assignment OSSD 8-pin (female connector)

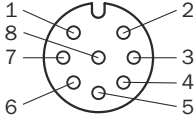
Female connector	Pin	Signal	Meaning	Color ¹⁾
	1	AUX_IN	Non-safe input	White
	2	VDC	24 V supply voltage for safety device	Brown
	3	AUX_OUT	Non-safe output	Green
	4	VDC	24 V supply voltage for safety device	Yellow
	5	OSSD1	Input OSSD1	Gray
	6	OSSD2	Input OSSD2	Pink
	7	GND	GND supply voltage for safety device	Blue
	8	VDC	24 V supply voltage for safety device	Red

¹⁾ The stated colors apply on the usage of pre-assembled cables (should be checked).

**NOTICE**

If multiple power supply units in a Flexi Loop section are connected in parallel, the loss of the GND connection can lead to overcurrent and cable fires.

- ▶ Connected OSSD devices should always be supplied with power via the OSSD female connector of the Flexi Loop node FLN-OSSD1000105 or FLN-OSSD1100108.
- ▶ OSSD devices must always be connected to the same voltage supply as the Flexi Loop node to which they are connected.
- ▶ Always use the power supply accessory to connect additional power supply units.
- ▶ **Never** use a separate power supply unit to supply power directly to a connected OSSD device.

6.2.7 Connections of the PWRI power supply accessory

Figure 45: Connections of the PWRI power supply accessory

- ① PWRI (male connector)

PWRI 5-pin

Table 23: Pin assignment PWRI 5-pin (male connector)

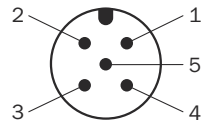
Male connector	Pin	Signal	Meaning	Color ¹⁾
	1	VDC	24 V supply voltage of the power supply connected	Brown
	2	VDC		White
	3	GND	GND from the power supply connected	Blue
	4	GND		Black
	5	NC	Not connected	Gray

¹⁾ The stated colors apply on the usage of pre-assembled cables (should be checked).

6.2.8 Connections of the MSTR1 Flexi Loop accessory

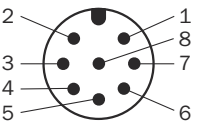

Figure 46: Connections of the MSTR1 Flexi Loop accessory

① FC_IN (male connector)

FC_IN 8-pin

Table 24: Pin assignment FC_IN 8-pin (male connector)

Male connector	Pin	Signal	Meaning	Color ¹⁾
	1	VDC	24 V supply voltage	White
	2	VDC	24 V supply voltage	Brown
	3	FC_A1	Test input 1	Green
	4	FC_A2	Safe output 1	Yellow
	5	GND	GND supply voltage	Gray
	6	GND	GND supply voltage	Pink
	7	FC_B1	Test input 2	Blue
	8	FC_B2	Safe output 2	Red

¹⁾ The stated colors apply on the usage of pre-assembled cables (should be checked).

6.2.9 Connections of the MSTR2 Flexi Loop accessory

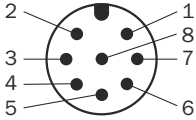

Figure 47: Connections of the MSTR2 Flexi Loop accessory

- ① FC_IN (male connector)
- ② IO-Link or AUX_IN/AUX_OUT (male connector)

FC_IN 8-pin

Table 25: Pin assignment FC_IN 8-pin (male connector)

Male connector	Pin	Signal	Meaning	Color ¹⁾
	1	VDC	24 V supply voltage	White
	2	VDC	24 V supply voltage	Brown
	3	FC_A1	Test input 1	Green
	4	FC_A2	Safe output 1	Yellow
	5	GND	GND supply voltage	Gray
	6	GND	GND supply voltage	Pink
	7	FC_B1	Test input 2	Blue
	8	FC_B2	Safe output 2	Red

¹⁾ The stated colors apply on the usage of pre-assembled cables (should be checked).

5-pin IO-Link or AUX_IN/AUX_OUT

Table 26: Pin assignment for IO-Link or AUX_IN / AUX_OUT 5-pin (male connector)

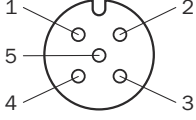
Male connector	Pin	Signal	Meaning	Color ¹⁾
	1	VDC	24 V IO-Link supply voltage ²⁾	Brown
	2	AUX_IN	Non-safe input	White
	3	GND	GND supply voltage	Blue
	4	C/Q or AUX_OUT	IO-Link interface/non-safe output	Black
	5	NC	Not connected	Gray

¹⁾ The stated colors apply on the usage of pre-assembled cables (should be checked).

²⁾ IO-Link and Flexi Loop must have separate supply voltages.

6.2.10 Connections of the DIAG Flexi Loop accessory



Figure 48: Connections of the DIAG Flexi Loop accessory

- ① FL_IN (male connector)
- ② FL_OUT (female connector)

FL_IN 5-pin

Table 27: Pin assignment FL_IN (male connector)

Male connector	Pin	Signal	Meaning	Color ¹⁾
	1	VDC	24 V supply voltage	Brown
	2	DATA_OUT	Output to the safety controller input In + 1	White
	3	GND	GND supply voltage	Blue
	4	SAFE_OUT	Safe cut-off signal Output to the safety controller input In	Black
	5	DATA_IN	Input from the safety controller output Xn	Gray

¹⁾ The stated colors apply on the usage of pre-assembled cables (should be checked).

6.2.11 Connection of Flexi Loop YCON1 and YCON2 adapters

The Flexi Loop YCON1 and YCON2 adapters are used to decouple the non-safe inputs and outputs of the Flexi Loop EMSS8 or OSSD8 nodes.

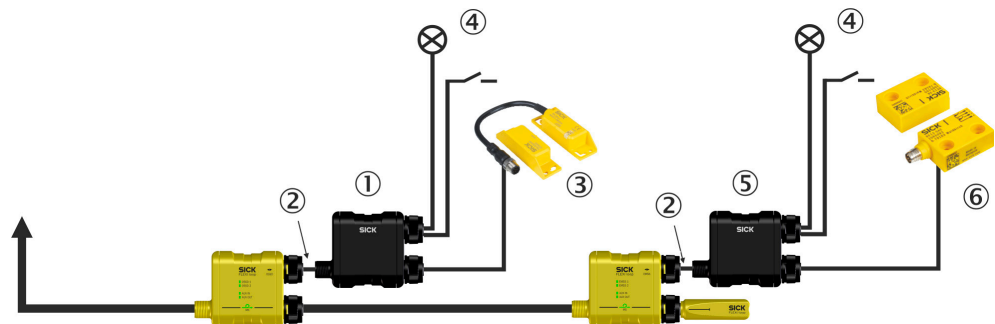

Figure 49: Connection of Flexi Loop adapters

- ① Flexi Loop YCON2 adapter
- ② Connecting cable
- ③ Switch with OSSD
- ④ Lamp at AUX_OUT, non-safe normally open at AUX_IN
- ⑤ Flexi Loop YCON1 adapter
- ⑥ Electro-mechanical safety switch (EMSS)

**NOTE**

Always connect the Flexi Loop YCON1 and YCON2 adapters to the Flexi Loop EMSS8 or OSSD8 node with a connecting cable. Do **not** plug the male connector on the Flexi Loop adapter directly into the female connector on the Flexi Loop node.

6.2.12 Connections of the Flexi Loop YCON1 adapter



Figure 50: Connections of the Flexi Loop YCON1 adapter

- ① 8-pin EMSS
- ② 5-pin AUX
- ③ 5-pin EMSS

8-pin EMSS

**NOTE**

Always use a connecting cable to connect the Flexi Loop YCON1 adapter to the Flexi Loop EMSS8 node. Do **not** plug the male connector on the Flexi Loop adapter directly into the female connector on the Flexi Loop node.

Table 28: Pin assignment 8-pin EMSS (male connector)

Male connector	Pin	Signal	Meaning	Color ¹⁾
	1	VDC	24 V supply voltage	White
	2	AUX_IN	Non-safe input	Brown
	3	EMSS1_A	Switching contact 1, connection A	Green
	4	EMSS1_B	Switching contact 1, connection B	Yellow
	5	AUX_OUT	Non-safe output	Gray
	6	GND	GND supply voltage	Pink
	7	EMSS2_A	Switching contact 2, connection A	Blue
	8	EMSS2_B	Switching contact 2, connection B	Red

¹⁾ The colors listed apply when using pre-assembled cables (no guarantee).

5-pin AUX

Table 29: 5-pin AUX pin assignment (female connector)

Female connector	Pin	Signal	Meaning
	1	VDC	24 V supply voltage
	2	AUX_IN	Non-safe input
	3	AUX_OUT	Non-safe output
	4	GND	GND supply voltage
	5	NC	Not connected

EMSS 5-pin

Table 30: Pin assignment EMSS 5-pin (female connector)

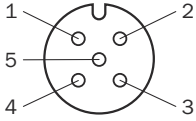
Female connector	Pin	Signal	Meaning	Color ¹⁾
	1	EMSS1_A	Switching contact 1, connection A	Brown
	2	EMSS1_B	Switching contact 1, connection B	White
	3	EMSS2_A	Switching contact 2, connection A ²⁾	Blue
	4	EMSS2_B	Switching contact 2, connection B	Black
	5	EMSS2_A	Switching contact 2, connection A ²⁾	Gray

1) The stated colors apply on the usage of pre-assembled cables (should be checked).
 2) You can either use Pin 3 or Pin 5 as connection A of switching contact 2.

6.2.13 Connections of the Flexi Loop YCON2 adapter



Figure 51: Connections of the Flexi Loop YCON2 adapter

- ① 8-pin OSSD
- ② 5-pin AUX
- ③ 5-pin OSSD

8-pin OSSD



NOTE

Always use a connecting cable to connect the Flexi Loop YCON2 adapter to the Flexi Loop OSSD8 node. Do **not** plug the male connector on the Flexi Loop adapter directly into the female connector on the Flexi Loop node.

Table 31: Pin assignment 8-pin OSSD (male connector)

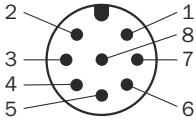
Male connector	Pin	Signal	Meaning	Color ¹⁾
	1	AUX_IN	Non-safe input	White
	2	VDC	24 V supply voltage for safety device	Brown
	3	AUX_OUT	Non-safe output	Green
	4	VDC	24 V supply voltage for safety device	Yellow
	5	OSSD1	Input OSSD1	Gray
	6	OSSD2	Input OSSD2	Pink
	7	GND	GND supply voltage for safety device	Blue
	8	VDC	24 V supply voltage for safety device	Red

¹⁾ The colors listed apply when using pre-assembled cables (no guarantee).

5-pin AUX

Table 32: 5-pin AUX pin assignment (female connector)

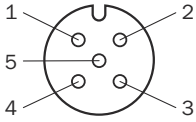
Female connector	Pin	Signal	Meaning
	1	VDC	24 V supply voltage
	2	AUX_IN	Non-safe input
	3	AUX_OUT	Non-safe output
	4	GND	GND supply voltage
	5	NC	Not connected

OSSD 5-pin

Table 33: Pin assignment OSSD 5-pin (female connector)

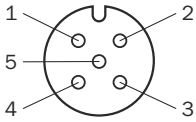
Female connector	Pin	Signal	Meaning	Color ¹⁾
	1	VDC	24 V supply voltage for safety device	Brown
	2	OSSD1	Input OSSD1	White
	3	GND	GND supply voltage for safety device	Blue
	4	OSSD2	Input OSSD2	Black
	5	AUX_IN	Non-safe input	Gray

¹⁾ The stated colors apply on the usage of pre-assembled cables (should be checked).



NOTICE

Never use a separate voltage supply unit to supply power directly to a connected OSSD device. If multiple voltage supply units are connected in parallel in a Flexi Loop section, the loss of the GND connection can lead to overcurrent and cable fires.

- ▶ Connected OSSD devices should always be supplied with power via the OSSD female connector of the Flexi Loop YCON2 adapter.
- ▶ OSSD devices must always be connected to the same voltage supply as the Flexi Loop node to which they are connected.
- ▶ Always use the power supply accessory to connect additional power supply units.

7 Configuration

7.1 Manipulation protection using the Flexi Loop MSTR accessory

If you are using the Flexi Loop safe series connection on a Flexi Classic safety controller, teach in the number of Flexi Loop nodes in the Flexi Loop MSTR accessory.

If you also want to specify the type of node, use the Flexi Loop MSTR2 accessory and configure it with a standard controller (see "Configuration of the Flexi Loop nodes", page 55).

7.1.1 Configuring the manipulation protection

Prerequisites

- Electrical and mechanical installation of the Flexi Loop line is complete.
- The X1 output of the Flexi Classic safety controller is connected to the FC_A1 connection of the Flexi Loop MSTR accessory, and the X2 output with the FC_B1 connection.
- **No** IO-Link connection has been established between the Flexi-Loop MSTR2 accessory and the IO-Link Master.
- The voltage supply is switched on, the operating mode LED is flashing red (1 Hz).

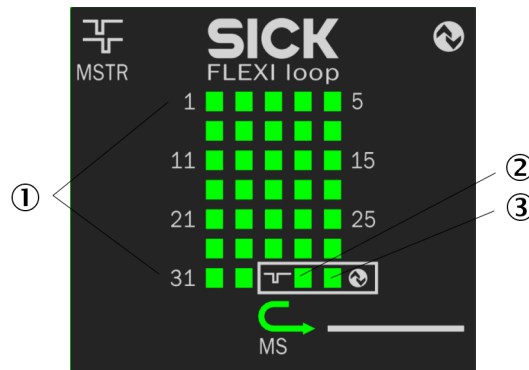

Figure 52: Flexi Loop MSTR accessory with operating mode LED

- ① Node LEDs 1 to 32
- ② Operating mode LED
- ③ IO-Link LED

Procedure

1. Switch off the Flexi Loop voltage supply and the IO-Link controller voltage supply.
2. Remove the wiring of the X1 output and wire the X2 output to the FC_A1 and FC_B1 connections.
3. Switch on the voltage supply.
- ✓ The configuration is saved, the operating mode LED flashes red/green in alternation.
- ✓ After successful saving, the operating mode LED flashes green (1 Hz).
4. Switch off the voltage supply.
5. Wire the X1 output to the FC_A1 connection again, and the X2 output exclusively to the FC_B1 connection.
6. Switch on the voltage supply.
- ✓ The Flexi Loop line is operational.
- ✓ The Flexi Loop MSTR accessory now checks at every switch on whether the correct the number of Flexi Loop nodes are connected.

Complementary information

To teach in a new configuration, carry out a new teach-in operation. This will irrevocably overwrite the existing configuration.

To delete in a configuration, carry out a new teach-in operation without terminal. The LED operating mode flashes red with 1 Hz after the teach-in operation has been completed (configuration required).

7.1.2 Deactivating the manipulation protection**Important information****WARNING**

Ineffectiveness of the protective device due to removal or bridging of Flexi Loop nodes
In the case of non-compliance, it is possible that the dangerous state of the machine may not be stopped or not stopped in a timely manner.

- ▶ Only deactivate manipulation protection when it is absolutely necessary to realize the application.
- ▶ In this case, take other steps (e.g. protected cable laying) to prevent possible manipulation.

Procedure

1. Connect a terminator to the Flexi Loop MSTR accessory.
 2. Perform a teach in.
- ✓ The Flexi Loop MSTR accessory will no longer check the number of nodes or the node types.

7.2 Security**WARNING**

Ineffectiveness of the protective device due to incorrect configuration

In the case of non-compliance, it is possible that the dangerous state of the machine may not be stopped or not stopped in a timely manner.

- ▶ Check the effectiveness of the protective device after any change to the configuration.

7.3 Configuration with a standard controller**Overview**

This chapter describes the key functions that can be set by IO-Link. The parameter list for all readable and writable data is available as a separate document (SICK part number 8017450).

Important information**WARNING**

Ineffectiveness of the protective device due to incorrect configuration

In the case of non-compliance, it is possible that the dangerous state of the machine may not be stopped or not stopped in a timely manner.

- ▶ Check the effectiveness of the protective device after any change to the configuration.

7.3.1 Prerequisites

Hardware

An IO-Link master, fulfilling the following requirements:

- IO-Link V1.1
- Communication mode COM1 (4.8 kBaud)
- TimeStamp function on the IO-Link master deactivated ⁴⁾

Software

All configuration notes relate to the configuration tool TwinCAT™ from Beckhoff.

Use the IO-Link device description (IODD) or the function block from the SICK library to integrate the Flexi Loop MSTR2 accessory into the hardware configuration of the project.

Use an IO-Link terminal or an IO-Link master to connect the standard controller and the Flexi Loop MSTR2 accessory (the rest of this document describes connection with an IO-Link master only).

When replacing the Flexi Loop MSTR2 accessory, you can easily restore the configuration of a Flexi Loop line if you use the **Data storage** function (supported by MSTR2 firmware version V1.02 and higher).

7.3.2 Configuring the hardware

1. Log into the configuration software for the standard controller as **Specialist**.
 2. Change to **Parameter** on the IO-Link port used.
 3. Open the **Parameter Menu** branch.
- ✓ The commands and parameters contained in the IODD are displayed.

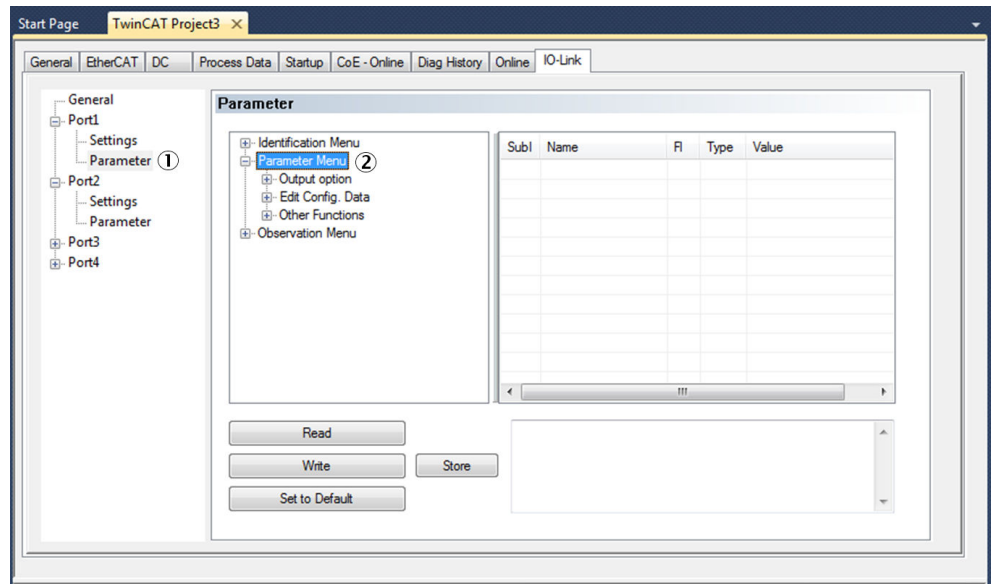

Figure 53: IODD commands and parameters

- ① Parameter
- ② Parameter Menu

4) If supported by the PLC.

7.3.2.1 Configuration of the Flexi Loop nodes

A safe series connection can contain up to 32 Flexi Loop nodes. The logical assignment of numbers ② begins after the Flexi Loop MSTR2 ① accessory at the first connected Flexi Loop node and ends with the terminator ③. Flexi Loop accessories (PWRI in the example) ④ can be installed between the Flexi Loop nodes. Flexi Loop accessories are not assigned a logical number.

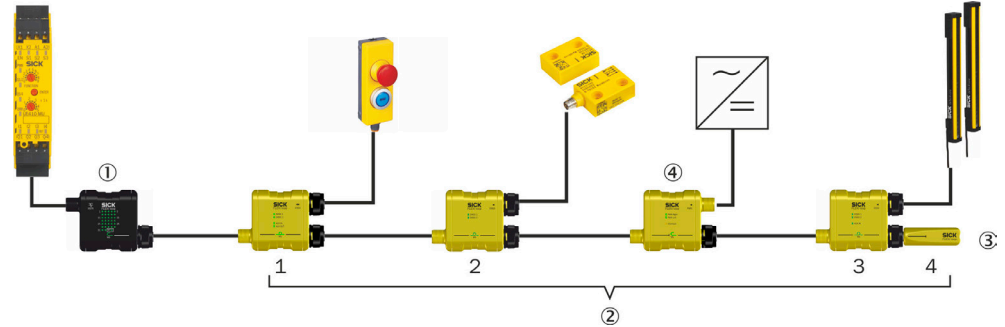

Figure 54: Logical numbering of the Flexi Loop nodes

- ① MSTR Flexi Loop accessory
- ② Logical numbering of the Flexi Loop nodes and the terminator
- ③ Terminator
- ④ Flexi Loop accessories (in the example PWRI)

7.3.2.1.1 Defining the number and types

Procedure

1. Open the **Edit Config. Data** branch.
- ✓ A subbranch is provided for every possible Flexi Loop node and the terminator (**Edit configuration data -Node 01 ... 33**).
2. Expand the **Edit configuration data -Node 01** branch.
- ✓ The system displays the configuration options for the Flexi Loop node.
3. In the **Node Type** menu, select the Flexi-Loop node type.
4. Repeat these steps for all Flexi Loop nodes of the Flexi Loop line.
5. Select Terminator for the last Flexi Loop node.
6. If there are any unused node positions, select the **Empty** type in the **Node Type** menu.
7. Save the configuration using Store ⁵⁾.

Complementary information

In the factory-set configuration, the first position is assigned to a Flexi Loop node FLN-EMSS1100108 and the second position to a Terminator

7.3.2.1.2 Deactivating output monitoring

Important information



WARNING

Incorrect reset signal due to deactivation of output monitoring
If this is not observed, a system or machine may start unexpectedly.

- If the AUX_IN input is used for resetting, **never** deactivate the output monitoring.

⁵⁾ Applies to TwinCAT™, alternatively use Store all User Data (SystemCommand 03h ParamDownloadStart - IO-Link Interface and System Specification V.1.1 Table B.9)

Procedure

For a Flexi Loop node with AUX_OUT and AUX_IN, the output status and input status are coupled by default. This means the status of the output cannot change while the input is switched (this suppresses any flashing mode that might be set).

Deactivate output monitoring if you want to use the AUX_OUT output independently of the status of the AUX_IN input. This may be necessary, for example, for safety locking devices.

1. Open the **Edit Config. Data** branch.
- ✓ A subbranch is provided for every possible Flexi Loop node and the terminator (**Edit configuration data -Node 01 ... 33**).
2. Expand the **Edit configuration data -Node [n]** branch of the desired Flexi Loop node.
- ✓ The system displays the configuration options for the Flexi Loop node.
3. Set the **Output monitoring** parameter to **Deactivated**.
4. Save the configuration using Store ⁶⁾.
- ✓ Output monitoring is inactive.

7.3.2.1.3 Deactivating AUX_IN to MSTR AUX_OUT

Procedure

If you are using several inputs to reset the protective device, the hazardous area must be visible from every reset button!

Flexi Loop is factory-set with a logical OR operation that links all inputs of Flexi Loop nodes. The result is output by the Flexi Loop MSTR2 accessory at the AUX_OUT output. You can use this function for a group reset signal in standard I/O mode, for example.

1. Set the **AUX_IN to MSTR AUX_OUT** parameter to **Off**.
2. Save the configuration using Store ⁶⁾.
- ✓ The Flexi Loop node will no longer forward the status of its AUX_IN to the AUX_OUT output of the Flexi Loop MSTR2 accessory.

7.3.2.1.4 Deactivating AUX_OUT from MSTR AUX_IN

Procedure

Flexi Loop links the status of the AUX_IN input of the Flexi Loop MSTR2 accessory with all AUX_OUT outputs of the Flexi Loop nodes. You can use this function, for example, to implement lock applications.

The process data for the AUX_OUT outputs of the individual Flexi Loop nodes and the logic states of the **AUX_OUT from MSTR AUX_IN** parameter are linked with a logical OR operation.

1. Set the **AUX_OUT from MSTR AUX_IN** parameter to **Off**.
2. Save the configuration using Store ⁶⁾.
- ✓ The AUX_OUT output of the Flexi Loop node is no longer linked to the AUX_IN of the Flexi Loop MSTR2 accessory.

7.3.2.1.5 Activating flashing mode 1 or 2

Procedure

Flash modes 1 and 2 can be used to have lamps at the non-safe outputs of the Flexi Loop nodes flash at a frequency of 1 Hz or 2 Hz.

1. Set the **Flashing mode 1** or **Flashing mode 2** parameter to **On**.
2. Save the configuration using Store ⁶⁾.
- ✓ When the AUX_OUT output of the Flexi-Loop node is activated, the output will be

⁶⁾ Applies to TwinCAT™, alternatively use Store all User Data (SystemCommand 03h ParamDownloadStart - IO-Link Interface and System Specification V.1.1 Table B.9)

controlled at 1 Hz or 2 Hz.

7.3.2.2 Configuration of the Flexi Loop string

7.3.2.2.1 Setting commissioning mode

Procedure

You can deactivate a taught-in configuration if you wish by placing the Flexi Loop MSTR2 accessory in commissioning mode.

1. Open the **Edit Config. Data** branch.
2. Expand the **Edit MSTR settings** branch.
- ✓ The system displays the configuration options for the Flexi Loop MSTR2 accessory.
3. In the **Commissioning mode** menu, select the **True** option.
4. Save the configuration using Store ⁷⁾.
- ✓ The Flexi Loop MSTR2 accessory goes into **Waiting for configuration** mode.

7.3.2.2.2 Deactivating the manipulation protection

Important information



WARNING

Ineffectiveness of the protective device due to removal or bridging of Flexi Loop nodes

In the case of non-compliance, it is possible that the dangerous state of the machine may not be stopped or not stopped in a timely manner.

- ▶ Only deactivate manipulation protection when it is absolutely necessary to realize the application.
- ▶ In this case, take other steps (e.g. protected cable laying) to prevent possible manipulation.

Procedure

You specify whether the number and type of Flexi Loop nodes should be checked when the device is switched on.

1. Open the **Edit Config. Data** branch.
2. Expand the **Edit MSTR settings** branch.
- ✓ The system displays the configuration options for the Flexi Loop MSTR2 accessory.
3. In the **Ignore node count** menu, select the **True** option.
4. Save the configuration using Store ⁷⁾.
- ✓ The number of Flexi Loop nodes will **not be checked** from now on.
5. In the **Ignore node types** menu, select the **True** option.
6. Save the configuration using Store ⁷⁾.
- ✓ The types of Flexi Loop nodes will **not be checked** from now on.

7.3.2.2.3 Changing the logic of the common input

Procedure

Flexi Loop is factory-set with a logical OR operation that links all inputs of the Flexi Loop nodes to a common input. The result is output by the Flexi Loop MSTR2 accessory at the AUX_OUT output. The link can be changed from OR to AND.

1. Open the **Edit Config. Data** branch.
2. Expand the **Edit MSTR settings** branch.
- ✓ The system displays the configuration options for the Flexi Loop MSTR2 accessory.

⁷⁾ Applies to TwinCAT™, alternatively use Store all User Data (SystemCommand 03h ParamDownloadStart - IO-Link Interface and System Specification V.1.1 Table B.9)

3. In the **MSTR AUX_OUT Logic** menu, select the **True** option.
4. Save the configuration using Store ⁸⁾.
- ✓ The inputs are linked with a logical AND operation.
5. In the **MSTR AUX_OUT Logic** menu, select the **False** option.
6. Save the configuration using Store ⁸⁾.
- ✓ The inputs are linked with a logical OR operation.

7.3.3 Options for application design in the PLC



WARNING

Ineffectiveness of the protective device due to the use of IO-Link information for safety-related applications

The intended safety level may not be achieved in the event of non-compliance.

- ▶ Only use the individual safety-related bit of the cut-off path for safety-related applications.
-

When the safe series connection is in operation and the sensors, switches, and actuators are connected, the safe series connection can be used in the process image of the standard controller.

The following information is available:

- cut-off path as IO-Link event
- non-safe inputs and outputs in the process data
- diagnostics information to the Flexi Loop string in the service data
- diagnostics information on the individual Flexi Loop nodes in the service data

The parameter list with all data that can be read and written is available as a separate document (SICK part number 8017450).

7.3.3.1 Cut-off path

The status of the cut-off path is available to the standard controller as an IO-Link event (code 6144, 1800h).

- If there is no shutdown and no error has occurred on any of the Flexi Loop nodes, the event is not present.
- If there has been a shutdown or an error has occurred on one of the sensors or switches, then the event is present.

7.3.3.2 Non-safe inputs and outputs

Process data

The non-safe inputs AUX_IN and outputs AUX_OUT are polled or set cyclically (IO-Link process data). The input or output signals are therefore available quickly in the process image or on the output.

The PLC and the MSTR2 Flexi Loop accessory communicate cyclically in a data frame for process data:

Flexi Loop transmits 4 bytes of input data to the PLC. These bytes contain the status of the non-safe inputs AUX_IN of the Flexi Loop nodes.

Flexi Loop receives 4 byte of output data from the PLC. These bytes contain the commands for the non-safe outputs AUX_OUT of the Flexi Loop nodes.

⁸⁾ Applies to TwinCAT™, alternatively use Store all User Data (SystemCommand 03h ParamDownloadStart - IO-Link Interface and System Specification V.1.1.1 Table B.9)

- Flexi Loop transmits 4 bytes of input data to the PLC. The 32 bits contain the status of the non-safe inputs AUX_IN of the Flexi Loop nodes.
bit 0 = Flexi Loop node 32, bit 31 = Flexi Loop node 1
bit = 1 = non-safe input active, bit = 0 = non-safe input inactive
- Flexi Loop receives 4 byte of output data from the PLC. The 32 bits contain the commands for the non-safe outputs AUX_OUT of the Flexi Loop nodes.
bit 0 = Flexi Loop node 32, bit 31 = Flexi Loop node 1
bit = 1 = non-safe output becomes active, bit = 0 = non-safe output becomes inactive

Response times

The pulse durations of the input signals from AUX_IN and the output signals on AUX_OUT are longer than the original signals due to the signal propagation times in the process image. The response time for the inputs and outputs comprise the following components:

- Propagation times for bits of non-safe inputs and outputs (see "[All Flexi Loop nodes and Flexi Loop accessories](#)", page 77).
- + transfer time IO-Link (cycle time x 2)
- + PLC process propagation time

7.3.3.3 Diagnostic information on the Flexi Loop safe series connection

The standard controller uses service data to poll non-safe diagnostic information.

Flexi Loop connection status

The value in index 275 (113h) displays the communication status within the safe series connection.

- The value is 0 if communication has been interrupted.
- The value is 1 or 2 if communication has been initialized.
- The value is 3 or 4 if communication is running.
- The value is 6 if the line is not connected (missing terminal, open line).
- The value is 7 if a configuration error (e. g. wrong number of nodes) is present.

Overall number of nodes

The value in index 276 (114h) corresponds with the number of nodes.

Safety controller status

The value in index 277 (115 h) indicates whether the signal from the connected safety controller has been recognized.

- The value is 0 if there is no supply voltage on FC_IN.
- The value is 1 if no safety controller was found on FC_IN.
- The value is 2 if a safety controller was found on FC_IN and the compatibility test is running.
- The value is 3 if a compatible safety controller was found on FC_IN and the Flexi Loop safe series connection is ready for use.

7.3.3.4 Diagnostics information on the individual Flexi Loop nodes

The indices 285 (11Dh) to 288 (120h) contain diagnostics information on the individual Flexi Loop nodes.

Each index is 4 bytes long. The 32 bits are each allocated to one of the Flexi Loop nodes:

- bit 0 = Flexi Loop node 32
- bit 31 = Flexi Loop node 1

Shutdown information

The value in index 285 (11Dh) indicates the output state of the safety sensors or safety switches connected to the Flexi Loop nodes. Bit 0 to 31 correspond to the Flexi Loop nodes 32 to 1.

- The bit is 1 if there is no shutdown on the Flexi Loop node.
- The bit is 0 if there is a shutdown.

Static testing

The value in index 286 (11Eh) indicates static errors (cross-circuit or short-circuit) on the safety sensors or safety switches connected to the Flexi Loop nodes. Bit 0 to 31 correspond to the Flexi Loop nodes 32 to 1.

- The bit is 1 if no error occurred.
- The bit is 0 if there is a cross-circuit or short-circuit.

Dynamic testing

The value in index 287 (11Fh) indicates dynamic errors (discrepancy or sequence error) on the safety sensors or safety switches connected to the Flexi Loop nodes. Bit 0 to 31 correspond to the Flexi Loop nodes 32 to 1.

- The bit is 1 if no error occurred.
- The bit is 0 if there is a discrepancy or sequence error.

Node detected

The value in index 288 (120h) indicates which of the Flexi Loop nodes is physically present. Bit 0 to 31 correspond to the Flexi Loop nodes 32 to 1.

- The bit is 1 if the Flexi Loop node is present.
- The bit is 0 if the Flexi Loop node is missing.

7.3.3.5 Output options

The output options for the Flexi Loop nodes can be changed in a volatile manner using the service data. Volatile parameters can only be used if the corresponding parameter in the configuration has been set to the value logical 0.

Each index is 4 bytes long. The 32 bits are each allocated to one of the Flexi Loop nodes:

- bit 0 = Flexi Loop node 32
- bit 31 = Flexi Loop node 1

Flashing mode 1 or 2

The index 281 (119h) sets the flashing mode 1 (1 Hz flashing) for the related Flexi Loop node.

The index 282 (11Ah) sets the flashing mode 2 (2 Hz flashing) for the related Flexi Loop node.

Bit 0 to 31 of the index correspond to the Flexi Loop nodes 32 to 1.

- If the bit is set to 1, flashing mode 1 or 2 becomes active.
- If the bit is set to 0, flashing mode 1 or 2 becomes inactive.

If the process data switch the output AUX_OUT on a Flexi Loop node, the output is operated at 1 Hz or 2 Hz (a lamp connected flashes).

Deactivate output monitoring

The index 283 (11Bh) sets the output monitoring for the related Flexi Loop node. Bit 0 to 31 of the index correspond to the Flexi Loop nodes 32 to 1.

- If the bit is set to 1, the output monitoring becomes inactive.
- If the bit is set to 0, the output monitoring becomes active.

7.3.3.6 Standard commands

Using standard commands you can trigger the pre-defined functions.

Factory settings

Using the command **Restore Factory Settings** you can reset the MSTR2 Flexi Loop accessory to the default delivery status.

Read voltages

You can read the operating voltage at the individual Flexi Loop nodes using the command **Read node voltage**.

- ▶ Enter the number of the Flexi Loop node in the index 472 (1D8h).
- ▶ Enter the value 192 in the index 2.
- ✓ The node voltage is then available in indices 401 (191h) through 433 (1B1h) depending on the node selection. The supply voltage is also available under Observation in the menu on the Flexi Loop MSTR accessory (see ["Diagnostics using the MSTR2 Flexi Loop accessory"](#), page 72).



NOTE

The Flexi Loop communication is interrupted while the node voltage is read. It is not possible to exchange process data during this time.

Restarting

With the command **Application Reset**, restart the safe series connection.

7.3.3.7 Events

When an event occurs, the safe series connection sends a signal to the IO-Link Master. The IO-Link master then reads the event.

State of the cut-off path

Event 6144 (1800h) **Flexi Loop interrupted** indicates whether the Flexi Loop safe series connection has been disabled.

- If there is no shutdown and no error has occurred on any of the Flexi Loop nodes, the event is **not present**.
- If there has been a shutdown or an error has occurred on one of the sensors or switches, then the event is **present**.

Safety controller synchronization

The event 6145 (1,801h) **Safety controller synchronization** indicates whether a safety controller was found.

- If a safety controller was detected, then the event is **not present**.
- If the connection to a safety controller has been interrupted, then the event is **present**.

Flexi Loop not in operation

Event 6152 (1808h) **Flexi Loop not operational** indicates whether communication within the Flexi Loop safe series connection is active.

- If communication is running, then the event is **not present**.
- If communication has been interrupted, then the event is **present**.

Cable connection

Event 6153 (1809h) **Cabling problem identified** indicates that the internal cable monitoring system has identified a problem with the Flexi Loop safe series connection's cabling.

- If the line is connected correctly and terminated with a terminal, then the event is **not present**.
- If the cables in the line are disconnected or not terminated with a terminal, then the event is **present**.

Dynamic error

The event 6146 (1802h) **Dynamic testing failed** indicates whether the dynamic testing of the safety sensors and safety switches connected was free of errors.

- If the dynamic testing on all the safe sensors and safety switches connected to the Flexi Loop nodes was successful, then the event is **not present**.
- If a dynamic error has occurred on one of the sensors or switches, then the event is **present**.

Static error

The event 6147 (1803h) **Static testing failed** indicates whether the static testing of the safety sensors and safety switches connected was free of errors.

- If the static testing on all the safety sensors and safety switches connected to the Flexi Loop nodes was successful, then the event is **not present**.
- If a static error has occurred on one of the sensors or switches, then the event is **present**.

Critical error

Event 6148 (1804h) **Critical error (hardware)** indicates whether damage to the Flexi Loop safe series connection or the Flexi Loop MSTR accessory hardware has been identified (damaged Flexi Loop node, short-circuits on connection cables, defective safety switch or safety sensor etc.).

- If the status of all hardware components is free from errors, then the event is **not present**.
- If a hardware error was identified, then the event is **present**.

Configuration difference

Event 6149 (1805h) **Configuration deviation** indicates whether the current physical structure of the Flexi Loop safe series connection corresponds with the anticipated configuration.

- If there is no deviation between the current structure and the anticipated configuration, then the event is **not present**.
- If the current structure deviates from the anticipated configuration, then the event is **present**.

8 Commissioning

8.1 Switching on

Prerequisites

- The machine has been inspected and released by qualified safety personnel.
- Protective device works properly.

Switching on

An LED test is run after switching on. Each LED lights up briefly in every available color during this test. The LED test is displayed simultaneously on all Flexi Loop nodes.

Synchronization of the Flexi Loop nodes then gets underway. After this, the LEDs indicate the corresponding operational status.

Further topics

- ["Status indicators", page 22](#)

8.2 Commissioning with the Flexi Loop DIAG or MSTR accessory

Commissioning mode

In the commissioning mode, the node LEDs 1 to 32 indicate the status of all Flexi Loop nodes connected to the right of the accessory.

The Flexi Loop DIAG accessory operates in commissioning mode if:

- Pin 1 (VDC) was connected to pin 5 (DATA_IN) at connection FL_IN before switching on the supply voltage.

The Flexi Loop MSTR accessory operates in commissioning mode if:

- No safety controller is connected.
- A valid configuration has not been taught in / is not available on the Flexi Loop MSTR1 or MSTR2 accessory.

Transparent mode of the Flexi Loop DIAG accessory

If the safety controller has been connected or commissioned, then the Flexi Loop DIAG accessory operates in transparent mode.

In the transparent mode the node LEDs 1 to 32 indicate the status of all Flexi Loop nodes connected. This statement applies to nodes connected both the left and right of the DIAG Flexi Loop accessory.

There is no restriction on the number of Flexi Loop DIAG accessories that can be used in a Flexi Loop line. This means that you can have diagnostic points virtually anywhere in your application.

8.3 Check during commissioning and modifications

The thorough check is intended to ensure that the safety functions are fulfilling their planned purpose and whether persons are being adequately protected.

- ▶ Carry out the checks specified in the test plan of the manufacturer of the machine and the operating entity.

9 Troubleshooting

9.1 In the event of faults or errors

Important information



WARNING

Cease operation if the cause of the malfunction has not been clearly identified!

- ▶ Immediately put the machine out of operation if you cannot clearly identify the error and if you cannot safely remedy the problem.



NOTICE

- ▶ Disconnect from the voltage supply before making any changes.
- ▶ Restart the system after restoring a lost connection or repairing a cable break.

9.2 Indications of the LEDs

9.2.1 MS LED

Indicators of the MS LEDs

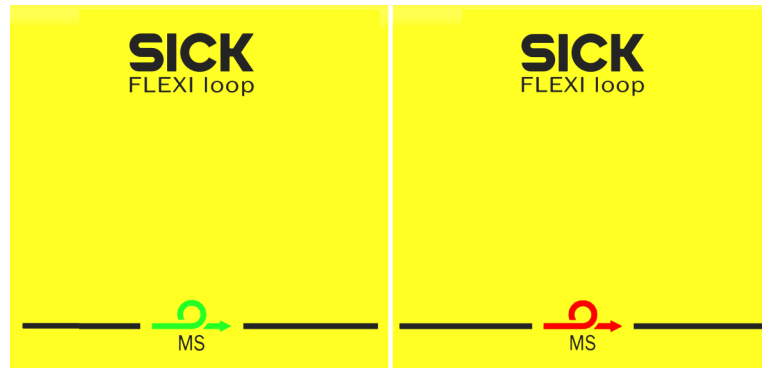

Figure 55: MS LED

Table 34: Displays of the MS LEDs

MS	Meaning
● Green	The safe series connection is in operation at this and all downstream Flexi Loop nodes and at all Flexi Loop accessories. No errors have occurred. On the FLN-EMSS0000105, FLN-EMSS1100108, FLN-OSSD1000105 and FLN-OSSD1100108 Flexi Loop nodes: If both EMSS LEDs or both OSSD LEDs at this node are not showing a steady green light, the safe series connection has been cut off by this node.
○	No operating voltage, or voltage too low
● Green (1 Hz)	A downstream Flexi Loop node has shut down or a discrepancy or sequence error has occurred on a downstream Flexi Loop node.
● Green (0.5 Hz)	Connection to Flexi Loop communication driver (e.g., Flexi Soft) exists but communication with the safe series connection has been interrupted. Or: More than 32 Flexi Loop nodes are connected to a line.
● Green (2 Hz)	Initialization phase, establishing communication.
● Green (1 Hz)	Communication interrupted, no communication with Flexi Loop communication driver (e.g., Flexi Soft)

MS	Meaning
● Red/green (2 Hz)	Configuration error <ul style="list-style-type: none"> Too many or too few nodes are connected to the safe series connection. Or: <ul style="list-style-type: none"> This node is not configured in this location (incorrect type or incorrect number).
● Red (1 Hz)	An error has occurred at this Flexi Loop node. The nature of the error is indicated by the combination of EMSS LEDs or OSSD-LEDs (see "LEDs of the EMSS Flexi Loop nodes", page 66 or see "LEDs of the OSSD Flexi Loop nodes", page 67).
● Red (2 Hz)	A critical error has occurred on a downstream node.
● Red	A critical error has occurred at this node. It may be possible to clear the error by shutting down and restarting.

○ LED off. ● LED flashes. ● LED illuminates.

Flexi Loop nodes with cutoff or error

The safe series connection is capable of covering long distances. The MS LEDs flash to indicate the Flexi Loop node that has been cut off or is affected by the error.

Start at the control cabinet and head toward the terminator until you find the Flexi Loop node whose LED is no longer flashing green at a frequency of 1 Hz. The cutoff or error has occurred at this Flexi Loop node.

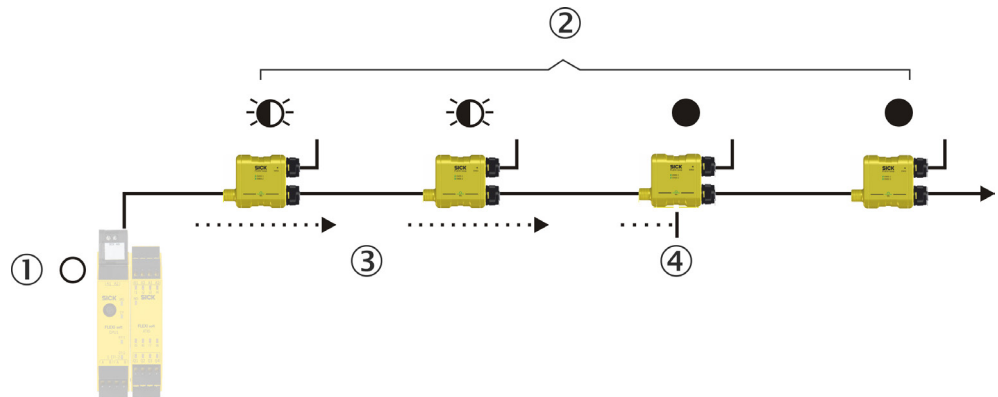

Figure 56: MS LEDs direction indicator

- ① I-LED of the safety controller
- ② MS-LEDs of the Flexi Loop nodes
- ③ Direction to the cutoff
- ④ Flexi Loop node with cutoff

9.2.2 LEDs of the EMSS Flexi Loop nodes

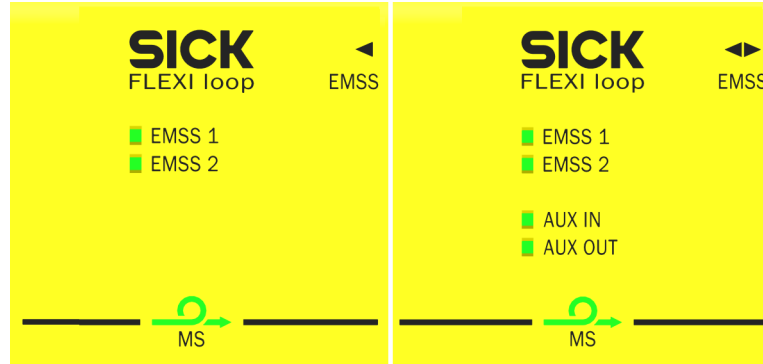

Figure 57: LEDs of the EMSS Flexi Loop nodes

Table 35: EMSS LEDs and MS LED of the EMSS Flexi Loop nodes

EMSS1/2	MS	Meaning
● Green	–	Switch contact 1 or 2 on the safety switch closed, no error
○	–	Switch contact 1 or 2 on the safety switch open, no error
◐ Green	◐ Red	Discrepancy or sequence error, related switch contact is closed.
◑ Green	◑ Red	Discrepancy or sequence error, related switch contact is open.

○ LED off. ◐ LED flashes. ● LED illuminates.

- If an error is only indicated on one of the LEDs EMSS1 or EMSS2 (the other is either illuminated green or is off), then there is a discrepancy error.
- If an error is indicated on both LEDs EMSS1 and EMSS2, there is a sequence error.

Table 36: AUX_IN LED of the EMSS Flexi Loop nodes

AUX_IN (8-pin variant only)	Meaning
● Green	Non-safe input is active.
○	Non-safe input is inactive.

○ LED off. ◐ LED flashes. ● LED illuminates.

Table 37: AUX_OUT LED of the EMSS Flexi Loop nodes

AUX_OUT (8-pin variant only)	Meaning
● Green	Non-safe output is active.
○	Non-safe output is inactive.

○ LED off. ◐ LED flashes. ● LED illuminates.

9.2.3 LEDs of the OSSD Flexi Loop nodes

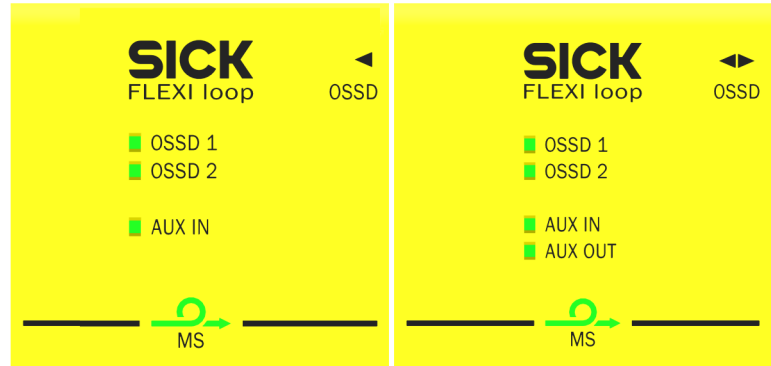

Figure 58: LEDs of the OSSD Flexi Loop nodes

Table 38: OSSD LEDs and MS LED of the OSSD Flexi Loop nodes

OSSD1/2	MS	Meaning
● Green	–	Connected OSSD in the ON state, no error
○	–	Connected OSSD in the OFF state, no error
◐ Green	◐ Red	Discrepancy or sequence error, related connection is high.
◑ Green	◑ Red	Discrepancy or sequence error, related connection is low.

○ LED off. ◐ LED flashes. ● LED illuminates.

Table 39: AUX_IN LED of the OSSD Flexi Loop nodes

AUX_IN	Meaning
● Green	Non-safe input is active.
○	Non-safe input is inactive.

○ LED off. ◐ LED flashes. ● LED illuminates.

Table 40: AUX_OUT LED of the OSSD Flexi Loop nodes

AUX_OUT (8-pin variant only)	Meaning
● Green	Non-safe output is active.
○	Non-safe output is inactive.

○ LED off. ◐ LED flashes. ● LED illuminates.

9.2.4 LEDs of the PWRI power supply accessory

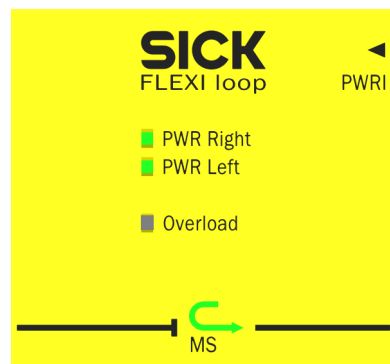

Figure 59: LEDs of the PWRI power supply accessory

Table 41: PWR Right LED of the PWRI power supply accessory

PWR Right	Meaning
● Green	Input voltage on the right side (on the male connector PWRI) is in the stipulated range
○	No or excessively low input voltage on the right side (on the male connector PWRI)

○ LED off. ● LED flashes. ● LED illuminates.

Table 42: PWR Left LED of the PWRI power supply accessory

PWR Left	Meaning
● Green	Operating voltage in the left section in the stipulated range
○	No or excessively low operating voltage in the left section

○ LED off. ● LED flashes. ● LED illuminates.

Table 43: Overload LED of the PWRI power supply accessory

Overload	Meaning
○	Output current in the normal range
● Red (1 Hz)	Output load is critical but not yet cut off. If this continues, cut-off will occur (see "PWRI power supply accessory", page 80).
● Red	Overload, all sections to the right of the power supply accessory are shut down. If the load drops below the re-enable value, the power supply accessory switches back on.
● Red (2 Hz)	Emergency shutdown, this error can only be cleared by switching off and on again.

○ LED off. ● LED flashes. ● LED illuminates.

9.2.5 LEDs of the MSTR1 Flexi Loop accessory

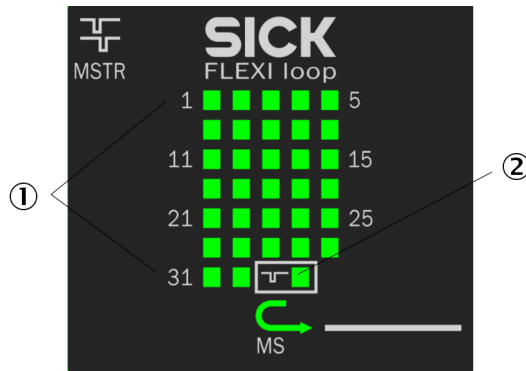

Figure 60: LEDs of the MSTR1 Flexi Loop accessory

- ① Node LEDs 1 to 32
- ② Operating mode LED

Table 44: Node LEDs of the MSTR1 and MSTR2 Flexi Loop accessory

Node LEDs 1 to 32	MS LED	Meaning
○	-	Node not found (not connected, not in operation)
● Green	-	OSSD or EMSS in the ON state
● Green	-	OSSD or EMSS in the OFF state
● Red	-	Sequence error occurred on the node

Node LEDs 1 to 32	MS LED	Meaning
◐ Red	–	Discrepancy error occurred on the node
◑ Green (2 Hz)	◑ Red/green (2 Hz)	Node found, corresponds to expected configuration
◑ Red/green (2 Hz)	◑ Red/green (2 Hz)	Node found, but does not correspond to the configured type or the number of nodes configured has been exceeded.
◐ Red (2 Hz)	◑ Red/green (2 Hz)	Configured node not found
◑ Red/green (1 Hz)	◑ Green (0.5 Hz)	Node found, but safe series connection interrupted (cable break detected). If multiple LEDs are flashing: The connection has probably been interrupted downstream of the Flexi Loop node whose LED is the last one flashing.
● Red (node 1)	◑ Green (0.5 Hz)	Number of Flexi Loop nodes allowed not reached
● Red (node 32)	◑ Green (0.5 Hz)	Number of Flexi Loop nodes allowed exceeded

○ LED off. ◑ LED flashes. ● LED illuminates.

Table 45: Operating mode LED of the MSTR1 and MSTR2 Flexi Loop accessories

Operating mode LED	Meaning
○	No operating voltage, or voltage too low
● Green	Compatible safety controller detected, safe series connection operational
● Orange	Safety controller found, compatibility test running
● Red	No safety controller found
◑ Red	Configuration required
◑ Red/green	Configuration process in progress, please wait
◑ Green	Configuration saved successfully, reboot required

○ LED off. ◑ LED flashes. ● LED illuminates.

9.2.6 LEDs of the MSTR2 Flexi Loop accessory

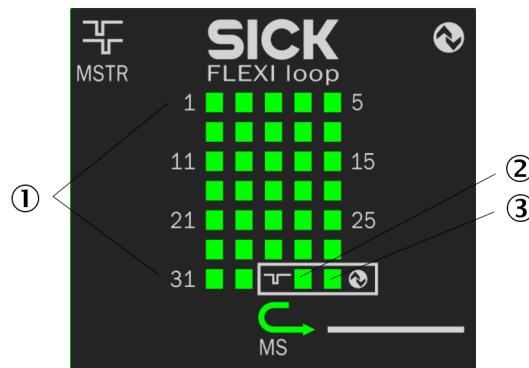

Figure 61: LEDs of the MSTR2 Flexi Loop accessory

- ① Node LEDs 1 to 32
- ② Operating mode LED
- ③ IO-Link LED

Table 46: Node LEDs of the MSTR1 and MSTR2 Flexi Loop accessory

Node LEDs 1 to 32	MS LED	Meaning
○	–	Node not found (not connected, not in operation)
● Green	–	OSSD or EMSS in the ON state
◐ Green	–	OSSD or EMSS in the OFF state
● Red	–	Sequence error occurred on the node
◐ Red	–	Discrepancy error occurred on the node
◐ Green (2 Hz)	◐ Red/green (2 Hz)	Node found, corresponds to expected configuration
◐ Red/green (2 Hz)	◐ Red/green (2 Hz)	Node found, but does not correspond to the configured type or the number of nodes configured has been exceeded.
◐ Red (2 Hz)	◐ Red/green (2 Hz)	Configured node not found
◐ Red/green (1 Hz)	◐ Green (0.5 Hz)	Node found, but safe series connection interrupted (cable break detected). If multiple LEDs are flashing: The connection has probably been interrupted downstream of the Flexi Loop node whose LED is the last one flashing.
● Red (node 1)	◐ Green (0.5 Hz)	Number of Flexi Loop nodes allowed not reached
● Red (node 32)	◐ Green (0.5 Hz)	Number of Flexi Loop nodes allowed exceeded

○ LED off. ◐ LED flashes. ● LED illuminates.

Table 47: Operating mode LED of the MSTR1 and MSTR2 Flexi Loop accessories

Operating mode LED	Meaning
○	No operating voltage, or voltage too low
● Green	Compatible safety controller detected, safe series connection operational
● Orange	Safety controller found, compatibility test running
● Red	No safety controller found
◐ Red	Configuration required
◐ Red/green	Configuration process in progress, please wait
◐ Green	Configuration saved successfully, reboot required

○ LED off. ◐ LED flashes. ● LED illuminates.

Table 48: IO-Link LED of the MSTR2 Flexi Loop accessory

IO-Link LED	Meaning
○	Standard IO mode
● Green	IO-Link mode, connection established to the IO-Link master
● Orange	IO-Link in Pre-operate modus
● Red	Error occurred in the IO-Link communication or: IO-Link output stage overloaded

○ LED off. ◐ LED flashes. ● LED illuminates.

9.2.7 LEDs of the DIAG Flexi Loop accessory

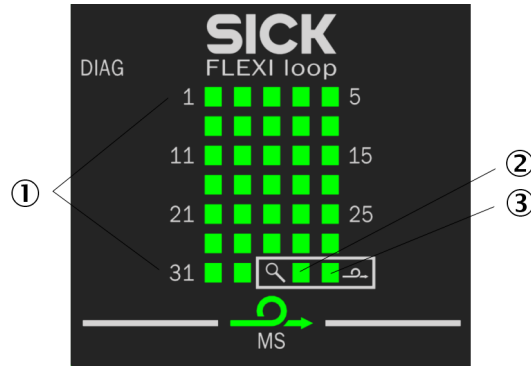

Figure 62: LEDs of the DIAG Flexi Loop accessory

- ① Node LEDs 1 to 32
- ② Operating mode LED
- ③ Loop integrity LED

Table 49: Node LEDs for the Flexi Loop DIAG accessory

Node LEDs 1 through 32	MS LED	Meaning
○	–	Node not found (not connected, not in operation)
● Green	–	OSSD or EMSS ON
◐ Green	–	OSSD or EMSS OFF
● Red	–	Sequence error has occurred at node
◐ Red	–	Discrepancy error has occurred at node
◐ Green (2 Hz)	◐ Red/green (2 Hz)	Node found, corresponds to expected configuration. ¹⁾
◐ Red/green (2 Hz)	◐ Red/green (2 Hz)	Node found but does not correspond to configured type or number of configured nodes has been exceeded. ²⁾
◐ Red (2 Hz)	◐ Red/green (2 Hz)	Configured node not found ³⁾
◐ Red/green (1 Hz)	◐ Green (0.5 Hz)	Node found, but safe series connection interrupted (cable break detected). If multiple LEDs are flashing: The connection has probably been interrupted downstream of the Flexi Loop node whose LED is the last one flashing.
● Red (node 1)	◐ Green (0.5 Hz)	Permissible number of Flexi Loop nodes under-shot
● Red (node 32)	◐ Green (0.5 Hz)	Permissible number of Flexi Loop nodes exceeded

○ LED off. ◐ LED flashes. ● LED illuminates.

- 1) Possible as of main module firmware 4.00 and MSTR firmware 1.03.
- 2) Possible as of main module firmware 4.00 and MSTR firmware 1.03.
- 3) Possible as of main module firmware 4.00 and MSTR firmware 1.03.

Table 50: Operating mode LED of the DIAG Flexi Loop accessory

Operating mode LED	Meaning
○	Detection of operating mode (initialization) Or: No supply voltage or supply voltage too low

Operating mode LED	Meaning
● Green	Safety controller found and synchronized, Flexi Loop DIAG accessory in transparent mode
● Orange	Flexi Loop DIAG accessory in commissioning mode
● Red	No valid input signal detected, critical error (restart required)

○ LED off. ● LED flashes. ● LED illuminates.

Table 51: Loop integrity LED on the DIAG Flexi Loop accessory

Loop integrity LED	Meaning
○	No operating voltage, or voltage too low
● Green	Flexi Loop communication is running
● Red	Flexi Loop communication interrupted (cable break detected) The connection has probably been interrupted downstream of the Flexi Loop node whose LED is flashing.
● Orange	Flexi Loop communication interrupted (cable break detected) The connection has probably been interrupted upstream of the Flexi Loop node whose LED is flashing.

○ LED off. ● LED flashes. ● LED illuminates.

9.3 Extended diagnostics

Use on programmable SICK safety controller

The software for configuring the programmable SICK safety controller supports advanced diagnostic options. These options allow you to further isolate the problem if the error situation is unclear or if there are availability issues.

Usage on the MSTR2 Flexi Loop accessory

The PLC uses service data to read out parameter values or statuses of Flexi Loop nodes.

The parameter list with all data that can be read and written is available as a separate document (SICK part number 8017450).

9.3.1 Diagnostics using the MSTR2 Flexi Loop accessory

If you have connected the Flexi Loop MSTR2 accessory to a programmable logic controller via the IO-Link, then you can retrieve diagnostic information for the safe series connection.

- ▶ Login to the configuration software for the standard controller as **Observer**.
- ▶ Change to **Parameter** on the IO-Link port used.
- ▶ Open there the **Observation Menu** branch.
- ✓ The test options contained in the IODD are displayed.

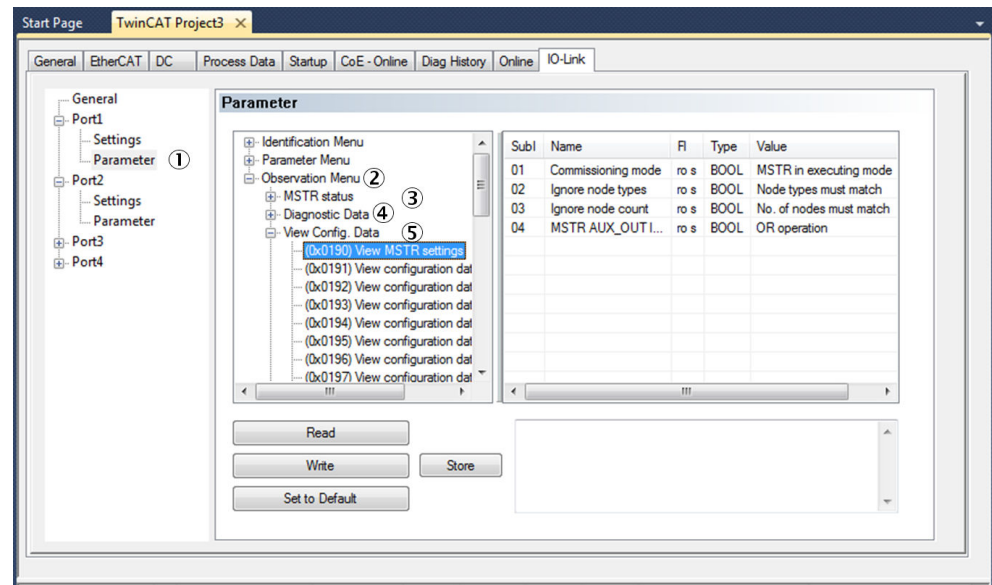

Figure 63: Observation Menu

- ① Parameter
- ② Observation Menu
- ③ MSTR status
- ④ Diagnostic Data
- ⑤ View Config. Data

Flexi Loop string

- ▶ Open the **MSTR Status** branch.
- ✓ The **Flexi Loop communication status** branch indicates the status of communication in the Flexi Loop safe series connection:
 - The value is 0 if communication has been interrupted.
 - The value is 1 or 2 if communication has been initialized.
 - The value is 3 or 4 if communication is running.
 - The value is 6 if the line is not connected (missing terminal, open line).
 - The value is 7 if a configuration error (e. g. wrong number of nodes) is present.
- ✓ The **Total node count** branch indicates the number of Flexi Loop nodes.
- ✓ The **Safety controller status** branch indicates whether the signal from the connected safety controller has been recognized:
 - The value is 0 if there is no supply voltage on FC_IN.
 - The value is 1 if no safety controller was found on FC_IN.
 - The value is 2 if a safety controller was found on FC_IN and the compatibility test is running.
 - The value is 3 if a compatible safety controller was found on FC_IN and the Flexi Loop safe series connection is ready for use.
- ✓ The **MSTR voltage** branch indicates the voltage on FC_IN.

Diagnostics information

- ▶ Open the **Diagnostic Data** branch.
- ✓ The branch shows the currently applicable status of the diagnostic data.

MSTR2 Flexi Loop accessory and Flexi Loop node

- ▶ Open the **View Config Data** branch.
- ✓ The **View MSTR settings** branch indicates the expected configuration for the MSTR2 Flexi Loop accessory.

- ✓ The **View configuration data [n]** branch indicates the anticipated configuration for all Flexi Loop node positions. It also displays information on the Flexi Loop nodes located at this position.

9.3.2 Test tools for the configuration

You can use the PLC to read information out from the Flexi Loop MSTR2 accessory.

- ▶ Login to the configuration software for the standard controller as **Observer**.
- ▶ Change to **Parameter** on the IO-Link port used.
- ▶ Change to **Observation Menu** in the command tree.
- ▶ Open the **Config. Check** branch.
- ✓ Test operations for the configuration are displayed.

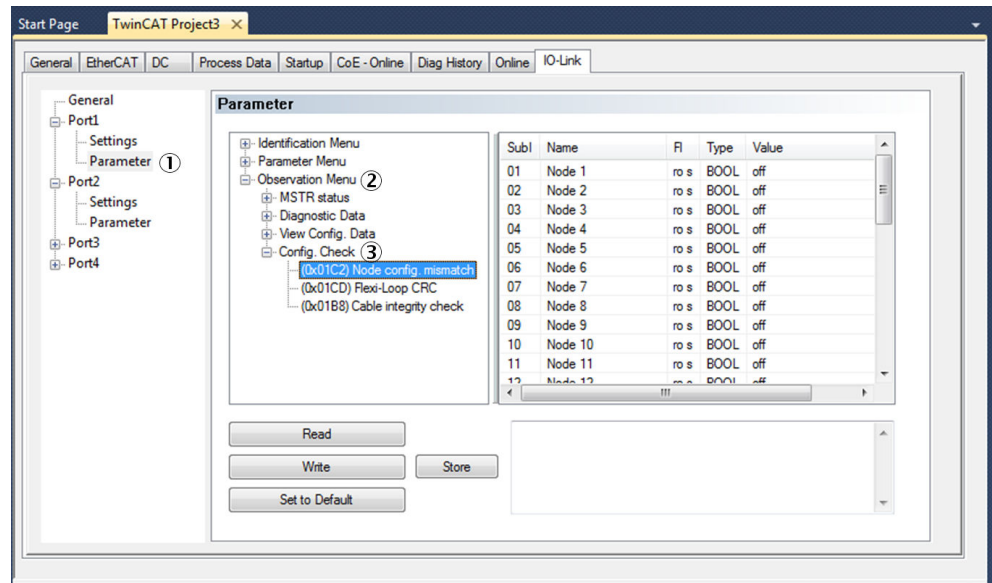

Figure 64: Test operations for the configuration

- ① Parameter
- ② Observation Menu
- ③ Config. Check

Config Error

Open an overview of incorrectly configured Flexi Loop nodes using the **Node config. mismatch** command.

The index is 4 bytes long. The 32 bits are each allocated to one of the Flexi Loop nodes. Bit 0 to 31 correspond to the Flexi Loop nodes 32 to 1.

- The bit is 1 if there is a different Flexi Loop node configuration.
- The bit is 0 if there is no difference.

Checksum

Using the **Flexi Loop CRC** command you can read the checksum for the currently valid configuration.

Cable connection

You can open information on possible cable breaks using the **Cable integrity check** command.

The subindex **Status** contains the status of the cables.

- 0: Cable connection OK, safe series connection connected
- 1: communication cable with short-circuit to GND
- 2: communication cable with short-circuit to VDC
- 3: More nodes than permitted and safe series connection disconnected
- 4: More nodes than permitted and safe series connection connected

The subindex **Position** contains the node position after which an interruption has been detected.

10 Decommissioning

10.1 Disposal

Procedure

- ▶ Always dispose of unusable devices in accordance with national waste disposal regulations.



Complementary information

SICK will be glad to help you dispose of these devices on request.

11 Technical data

11.1 Data sheet

11.1.1 Overall system

Safety-related parameters

The data apply to an ambient temperature of +40 °C.

Table 52: Safety-related parameters

Safety integrity level (IEC 61508)	SIL 3
Safety integrity level (IEC 62061)	
Category (ISO 13849)	Category 4
Performance level (ISO 13849)	PL e
PFH _D (mean probability of a dangerous failure per hour) For Flexi Loop safe series connection	0.76 × 10 ⁻⁹
T _M (mission time, ISO 13849)	20 years

Complementary information

For detailed information on the safety configuration of your machine/system, please consult your SICK subsidiary.

11.1.2 All Flexi Loop nodes and Flexi Loop accessories

Table 53: Flexi Loop nodes and Flexi Loop accessories data sheet

	Flexi Loop nodes and Flexi Loop accessories
General data	
Protection class (IEC 61140)	III
Enclosure rating (IEC 60529)	IP 65 and IP 67 UL type 1
Ambient operating temperature (UL/CSA: surrounding air temperature)	-25 °C ... +55 °C
Storage temperature	-25 °C ... +70 °C
Air humidity	≤ 95%, non-condensing
Shock resistance, continuous shock	10 g, 16 ms (EN 60068-2-64)
Shock resistance, single shock	30 g, 11 ms (EN 60068-2-27)
Electromagnetic compatibility	Class A (EN 61000-6-2, EN 55011)
Dimensions ¹⁾ (W × H × D)	68.15 × 48 × 18 mm
Weight ¹⁾	28 g (± 5%)
Housing material	Polycarbonate (PC) Acrylonitrile butadiene styrene (ABS) Polyester
M12 plug connector torque	Max. 0.2 Nm
Response time with Flexi Soft	For the response time of the Flexi Soft safety controller (see section "Calculating response times" in the Flexi Soft hardware operating instructions), the following value must be added to the total E1 (case b = type 4 testable sensors): 10 ms

Flexi Loop nodes and Flexi Loop accessories	
Response time with Flexi Compact	For the response time of the Flexi Compact safety controller (see section “Technical data” in the Flexi Compact operating instructions) consider the response time for processing incoming and outgoing process data (Flexi Loop diagnostic data).
Response time with Flexi Classic	For the response time of the Flexi Classic safety controller (see section “Technical data” in the Flexi Classic operating instructions), the following value must be added to the “response time when Flexi Loop is connected” value: 10 ms
Minimum cut-off time	
FLN-OSSD ⁷⁾	10 ms
FLN-EMSS ⁸⁾	40 ms
Minimum restart time ²⁾	120 ms
Max. power-up delay after the supply voltage is switched on	
FLN-OSSD, FLN-EMSS, and FLA-DIAG	5 s
FLA-PWRI	10 s
FLA-MSTR	30 s
Propagation times for diagnostic bits and bits of non-safe inputs and outputs	
AUX_IN ³⁾	
1 ... 8 Flexi Loop nodes	404 ms
9 ... 16 Flexi Loop nodes	540 ms
17 ... 24 Flexi Loop nodes	668 ms
25 ... 32 Flexi Loop nodes	796 ms
AUX_OUT ³⁾	
1 ... 8 Flexi Loop nodes	305 ms
9 ... 16 Flexi Loop nodes	441 ms
17 ... 24 Flexi Loop nodes	569 ms
25 ... 32 Flexi Loop nodes	697 ms
DIAG_IN ^{3) 4)}	
1 ... 8 Flexi Loop nodes	712 ms
9 ... 16 Flexi Loop nodes	1,400 ms
17 ... 24 Flexi Loop nodes	2,288 ms
25 ... 32 Flexi Loop nodes	3,376 ms
DIAG_OUT ^{3) 4)}	
1 ... 8 Flexi Loop nodes	708 ms
9 ... 16 Flexi Loop nodes	1,396 ms
17 ... 24 Flexi Loop nodes	2,284 ms
25 ... 32 Flexi Loop nodes	3,372 ms
Electrical data	
Supply voltage (U _V)	16.8 ... 30 V DC
Supply voltage for UL / CSA applications	24 V DC
Type of supply voltage	SELV or PELV
Overvoltage cut-off	At 34.5 V DC ±2 V DC
Undervoltage cut-off	At 15.5 V DC ±1 V DC
Maximum current at 40 °C	4 A ⁵⁾
Maximum current at 55 °C	3.19 A

Flexi Loop nodes and Flexi Loop accessories	
Current in Flexi Loop communication inputs	3 ... 6.2 mA
Maximum short-circuit currents (Flexi Loop communication and test outputs)	13.5 mA
Current consumption	
FLN-OSSD	45 mA
FLN-EMSS	55 mA
FLA-PWRI	30 mA (PWR left) / 55 mA (PWR right)
FLT-TERM	30 mA
FLA-DIAG	60 mA
FLA-MSTR	60 mA
System connection	M12 male/female connector ⁶⁾

- 1) Not terminator.
- 2) Minimum time which must elapse following switching off before a restart.
- 3) Applies for a runtime within the logic of 4 ms.
- 4) Applies when an event occurs.
- 5) The current for the power supply unit used for the Flexi Loop must be limited externally to max. 4 A either by the power supply unit itself or using a fuse.
- 6) Terminator, male connector only.
- 7) Time without sensor; the data from the connected sensors also applies.
- 8) Included automatically in the calculation of the overall response time for the safety controller and the Flexi Loop safe series connection.

11.1.3 Flexi Loop EMSS nodes

Table 54: Data sheet for Flexi Loop EMSS nodes

FLN-EMSS0000105 FLN-EMSS1100108	
EMSS inputs/outputs	
Test pulse width	12 ms
Test pulse interval	40 ms
Current due to test pulses via switching contacts	3 ... 6.2 mA AC ¹⁾ at U _v -3 V
Discrepancy time monitoring	3 s

- 1) Alternating current pulsating with test gaps.

Table 55: Additional data for 8-pin variant FLN-EMSS1100108

FLN-EMSS1100108	
Non-safe input (AUX_IN)	
Logic level switching points	
HIGH	> 13 V / 3.5 mA
LOW	< 5 V / 2.5 mA
Maximum input current	6.2 mA
Debouncing	100 ms
Non-safe output (AUX_OUT)	
Type of output	High-side driver, short-circuit protected
Output current	Max. 500 mA
Permissible capacitive load	Max. 1 µF
Internal discharging resistance	Typically 200 kOhm

11.1.4 Flexi Loop OSSD nodes

Table 56: Data sheet OSSD Flexi Loop node

FLN-OSSD1000105 FLN-OSSD1100108	
OSSD inputs	
Input voltage HIGH	13 V DC ... 30 V DC
Input voltage LOW	-5 V DC ... +5 V DC
Input current HIGH	3.5 mA ... 6.2 mA
Input current LOW	-2.5 mA ... +2.5 mA
Test pulse width ¹⁾	<1 ms
Discrepancy time monitoring	3 s
Voltage supply for OSSD devices	
Supply voltage	16.8 V DC ... 30 V DC
Maximum current	
FLN-OSSD1000105 at 40 °C	3.9 A
FLN-OSSD1100108 at 40 °C	2 A
FLN-OSSD1000105 at 55 °C	3.1 A
FLN-OSSD1100108 at 55 °C	1.5 A
Non-safe input (AUX_IN)	
Logic level switching points	
HIGH	>13 V/3.5 mA
LOW	<5 V/2.5 mA
Maximum input current	6.2 mA
Debouncing	100 ms

¹⁾ Is defined by the OSSD device.

Table 57: Additional data for 8-pin FLN-OSSD1100108 variant

FLN-OSSD1100108	
Non-safe output (AUX_OUT)	
Type of output	Highside driver, short-circuit protected
Output current	Max. 500 mA
Permissible capacitive load	Max. 1 µF
Internal discharging resistance	Typical 200 kOhm

11.1.5 Terminator

Table 58: Data sheet FLT-TERM00001 terminator

FLT-TERM00001	
Dimensions terminator (W × H × D)	54 mm × 13.6 mm × 13.6 mm
Weight terminator	8 g (±5 %)
Current consumption	30 mA

11.1.6 PWRI power supply accessory

Table 59: Data sheet PWRI power supply accessory

FLA-PWRI00001	
Electrical data	

	FLA-PWRI00001
Internal resistance	Approx. 50 mΩ
Output current monitoring	
Permissible capacitive load	Max. 4.7 mF
Permissible inductive load	Max. $L = 0.74 \text{ J/I}^2$ e.g.: 0.18 H @ 2.0 A 2.90 H @ 0.5 A
Overcurrent monitoring	
Inrush current within 20 ms	Max. 40 A
Surge when switched on with capacitive load change	Max. 20 A

Characteristic curve

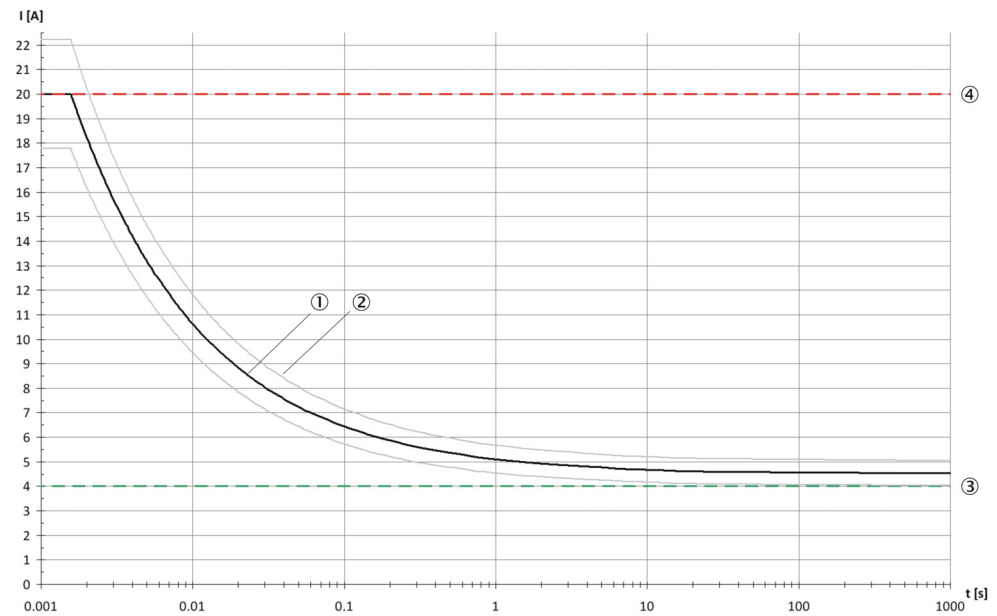

Figure 65: Characteristic curve for PWRI power supply accessory

- ① Current characteristic at 40 °C
- ② Tolerance
- ③ Permissible continuous current
- ④ Emergency shutdown

11.1.7 MSTR Flexi Loop accessory

Table 60: Data sheet MSTR Flexi Loop accessory

	FLA-MSTR00001 FLA-MSTR00002
Test inputs for the Flexi Classic connection layout (FC_A1 and FC_B1)	
Input voltage HIGH	13 V DC ... 30 V DC
Input voltage LOW	-5 V DC ... +5 V DC
Input current HIGH	3.5 mA ... 6.2 mA
Input current LOW	-2.5 mA ... +2.5 mA
Test outputs for the Flexi Classic connection layout (FC_A2 and FC_B2)	
Maximum short-circuit currents	13.5 mA

Table 61: Additional data for FLA-MSTRO0002 variant with IO-Link interface

FLA-MSTRO0002	
General electrical data	
Supply voltage (V _S) on usage of IO-Link	18 V DC ... 30 V DC
Non-safe output (C/Q or AUX_OUT)	
Type of output	Highside driver, short-circuit protected, or IO-Link
Output current	Max. 50 mA
Permissible capacitive load	Max. 100 nF
Debouncing	100 ms
Non-safe input (AUX_IN)	
Logic level switching points	
HIGH	>13 V/3.5 mA
LOW	<5 V/2.5 mA
Maximum input current	6.2 mA
Debouncing	100 ms

11.2 Dimensional drawings

11.2.1 Flexi Loop node dimensional drawing

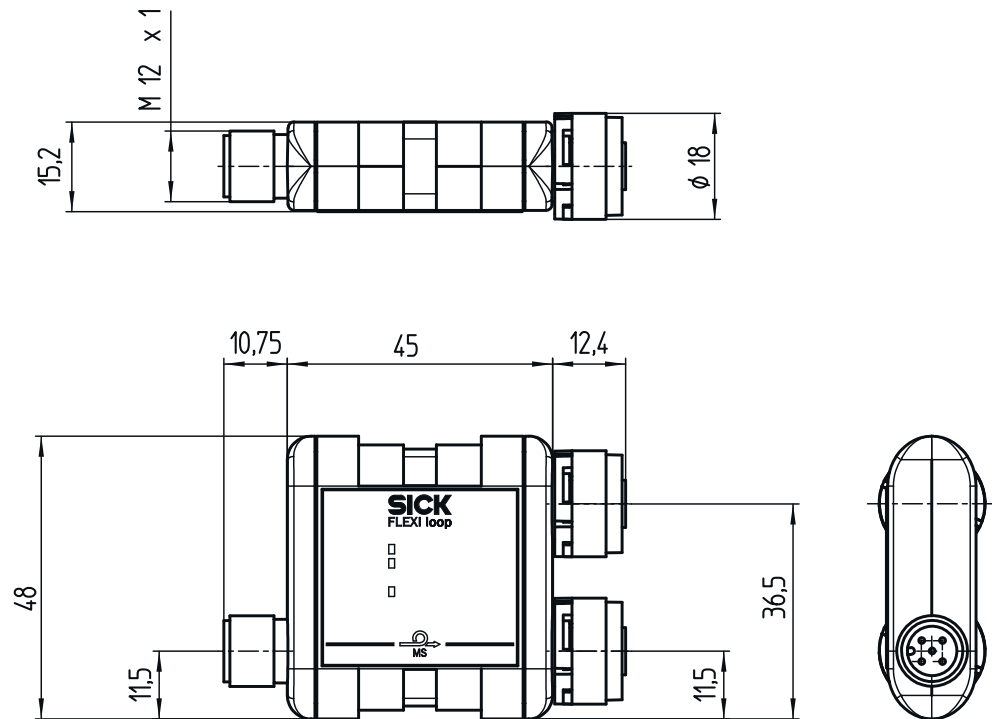

Figure 66: Flexi Loop node dimensional drawing (mm)

11.2.2 PWRI power supply accessory dimensional drawing

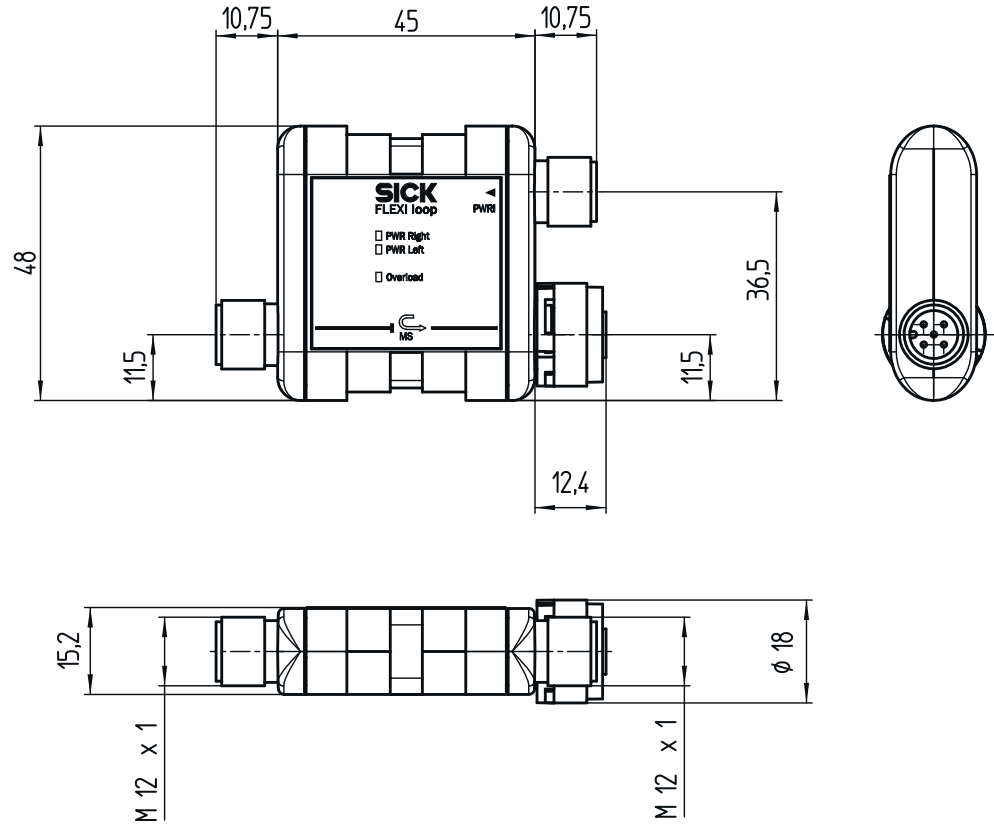

Figure 67: PWRI power supply accessory dimensional drawing (mm)

11.2.3 Terminator dimensional drawing

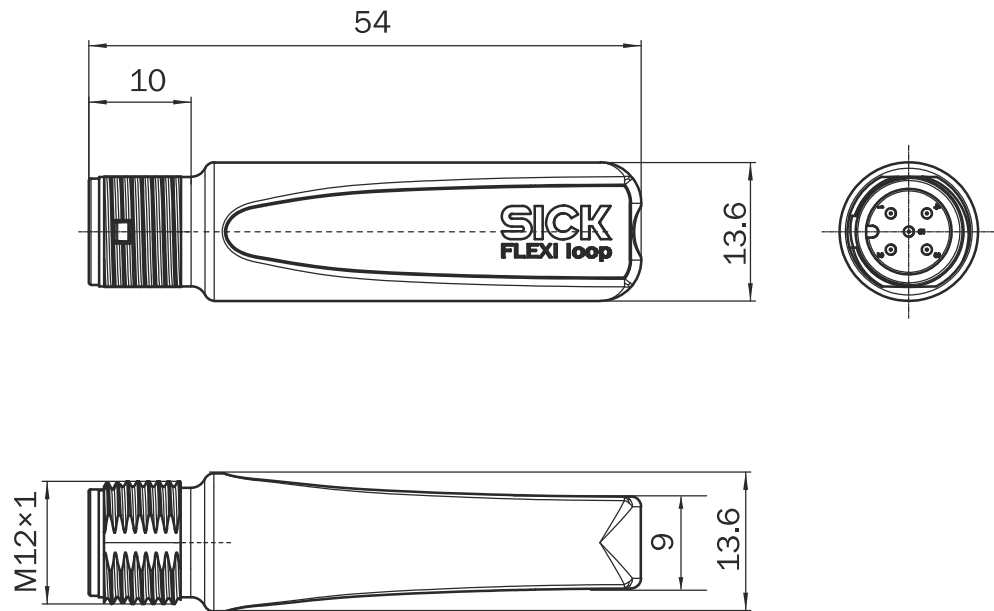

Figure 68: Terminator dimensional drawing (mm)

11.2.4 C-Fix bracket dimensional drawing

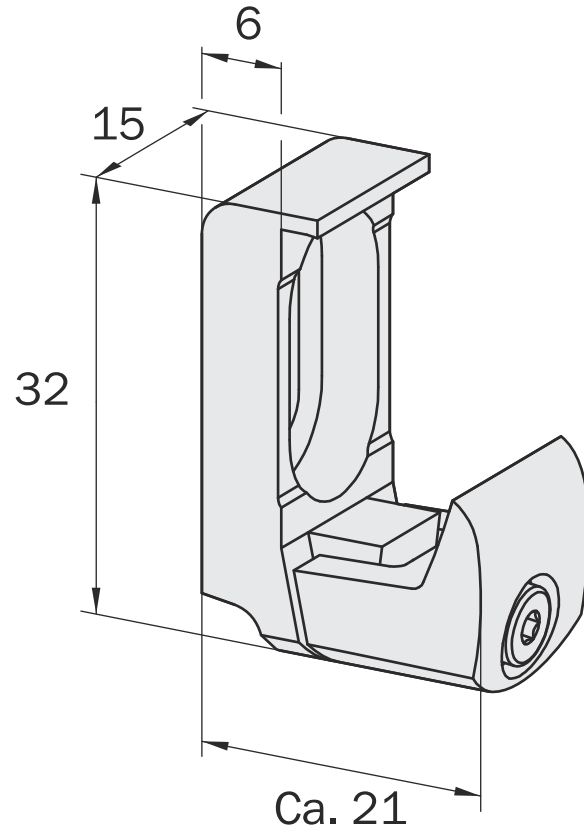

Figure 69: C-Fix bracket dimensional drawing (mm)

11.2.5 MSTR Flexi Loop accessory dimensional drawing

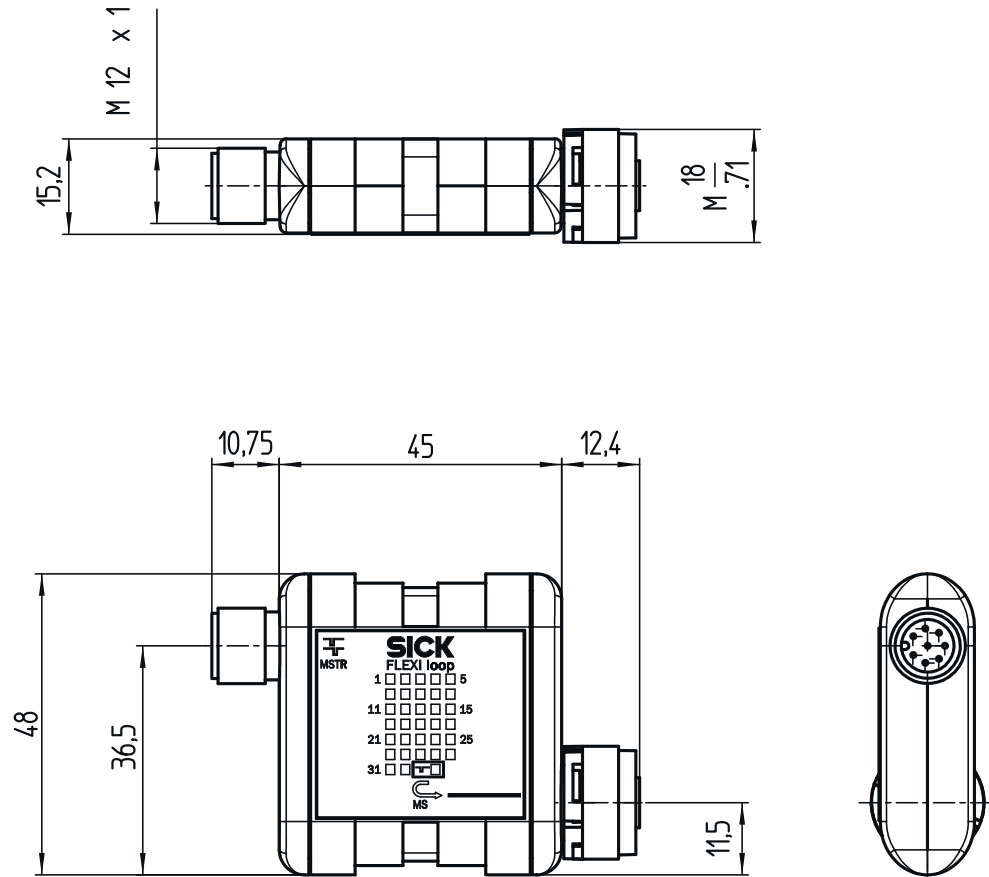

Figure 70: FLA-MSTR00001 Flexi Loop accessory dimensional drawing (mm)

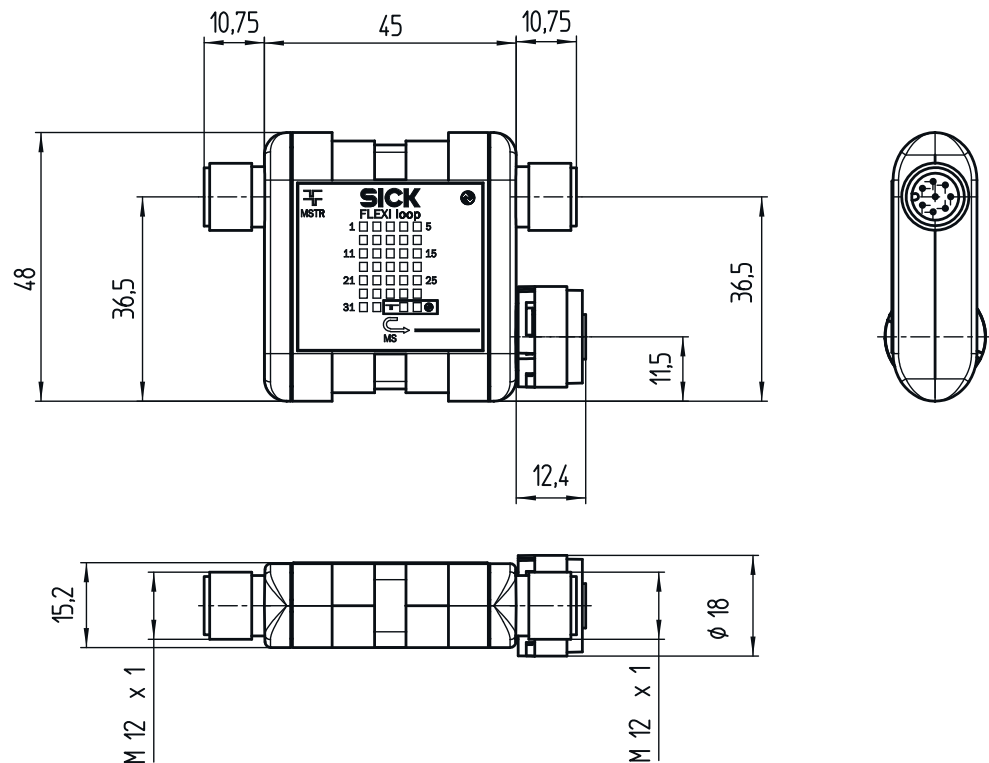

Figure 71: FLA-MSTR00002 Flexi Loop accessory dimensional drawing (mm)

11.2.6 DIAG Flexi Loop accessory dimensional drawing

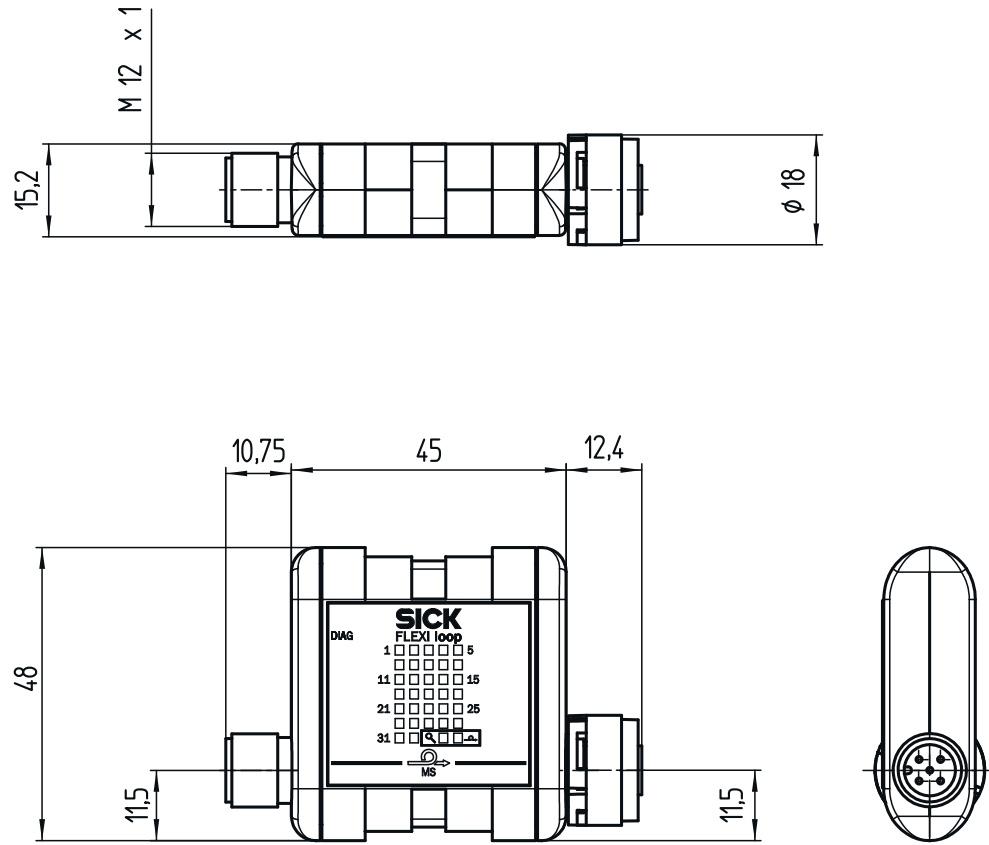

Figure 72: DIAG Flexi Loop accessory dimensional drawing (mm)

11.2.7 YCON Flexi Loop adapter dimensional drawing

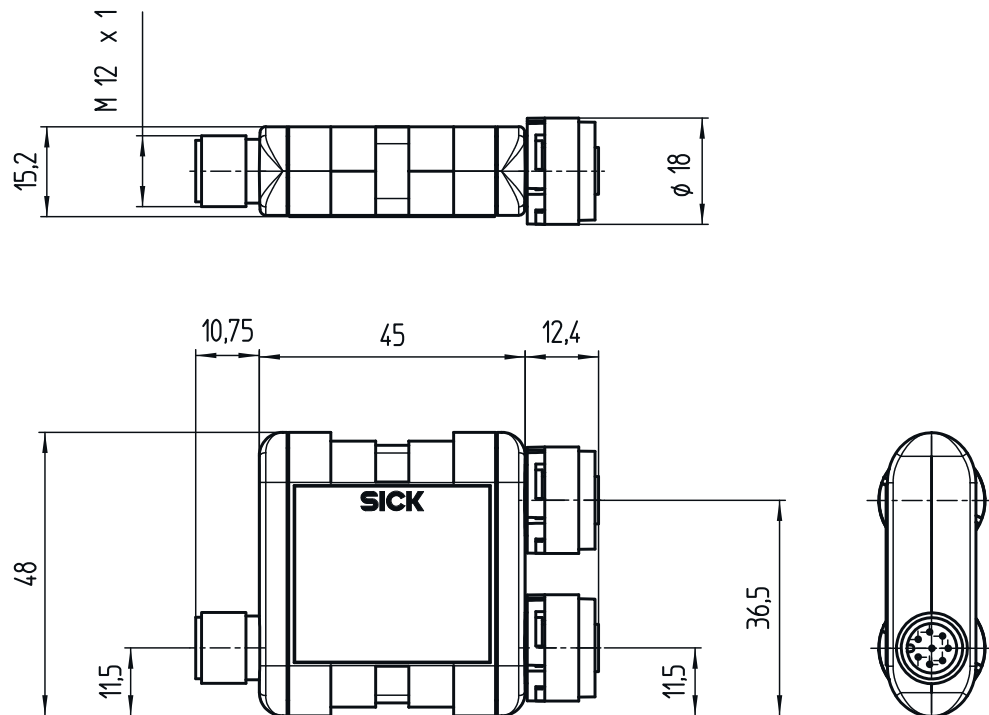

Figure 73: FLA-YCON Flexi Loop connection adapter dimensional drawing (EMSS/OSSD)

11.3 Compatibility

Table 62: Compatibility

Function	Supported as of module with firmware
Flexi Loop general	FX3-CPUx with firmware V3.xx or higher In addition: FX3-XTIO with firmware V3.xx or higher FX3-XTDI with firmware V3.xx or higher FX3-XTDS with firmware V3.xx or higher
Flexi Loop DIAG accessory	FX3-CPUx with firmware V3.01 or MSTR1/MSTR2 with firmware V1.01
Automatic cable break detection Display of configuration errors with the Flexi Loop DIAG accessory	FX3-CPUx with firmware V4.00 or MSTR1 / MSTR2 with firmware V1.02

12 Ordering information

12.1 Scope of delivery

- Flexi Loop node or Flexi Loop accessory depending on order
- general safety notes

12.2 Flexi Loop node

Table 63: Ordering information for Flexi Loop nodes

Part	Type code	Part number
Flexi Loop node for a safety sensor with monitored semiconductor output (OSSD) with one non-safe input	FLN-OSSD1000105	1061709
Flexi Loop node for a safety sensor with monitored semiconductor output (OSSD) with one non-safe input with one non-safe output	FLN-OSSD1100108	1061710
Flexi Loop node for a dual-channel, equivalent switching, electro-mechanical safety switch	FLN-EMSS0000105	1061711
Flexi Loop node for a dual-channel, equivalent switching, electro-mechanical safety switch with one non-safe input with one non-safe output	FLN-EMSS1100108	1061712

12.3 Flexi Loop accessories

Table 64: Ordering information for Flexi Loop accessories

Part	Type code	Part number
Flexi Loop accessories for supply of power for electrical isolation for overcurrent shutdown	FLA-PWRI00001	1061715
Flexi Loop termination element	FLT-TERM00001	1061716
Flexi Loop accessories for connection to Flexi Classic or to safe relay for system monitoring during commissioning/in operation	FLA-MSTRO0001	1061713
Flexi Loop accessories for connection to Flexi Classic or to safe relay for system monitoring during commissioning/in operation IO-Link interface for diagnostics and standard IO controller	FLA-MSTRO0002	1067650
Flexi Loop accessories for system monitoring during commissioning/in operation	FLA-DIAG00001	1061714

Part	Type code	Part number
Flexi Loop adapter (EMSS) <ul style="list-style-type: none"> • FLN: male connector, M12, 8-pin • AUX: female connector, M12, 5-pin • EMSS: female connector, M12, 5-pin 	FLA-YCON00001	2074733
Flexi Loop adapter (OSSD) <ul style="list-style-type: none"> • FLN: male connector, M12, 8-pin • AUX: female connector, M12, 5-pin • OSSD: female connector, M12, 5-pin 	FLA-YCON00002	2074734

13 Accessories

13.1 Plug connectors

Table 65: Part numbers plug connectors

Part	Type code	Part number
Male connector, M12, IP 67, 5-pin, I _{max} 4 A	STE-1205-G	6022083
Male connector, M12, IP 67, 8-pin, I _{max} 2 A	STE-1208-G	6033269
Female connector, M12, IP 67, 5-pin, I _{max} 4 A	DOS-1205-G	6009719
Female connector, M12, IP 67, 8-pin, I _{max} 2 A	DOS-1208-G	6028422

13.2 Pre-assembled cables

Table 66: Part numbers pre-assembled cables

Part	Type code	Part number
Male connector, M12, 5-pin, straight, A-coded, flying leads, 5 x 0.34 mm ² , 1 m	YM2A15-010UB5XLEAX	2095104
Male connector, M12, 5-pin, straight, A-coded, flying leads, 5 x 0.34 mm ² , 2 m	YM2A15-020UB5XLEAX	2095840
Male connector, M12, 5-pin, straight, A-coded, flying leads, 5 x 0.34 mm ² , 5 m	YM2A15-050UB5XLEAX	2095842
Male connector, M12, 5-pin, straight, A-coded, flying leads, 5 x 0.34 mm ² , 10 m	YM2A15-100UB5XLEAX	2095843
Male connector, M12, 8-pin, straight, A-coded, flying leads, 8 x 0.25 mm ² , 1 m	YM2A18-010UA5XLEAX	2095871
Male connector, M12, 8-pin, straight, A-coded, flying leads, 8 x 0.25 mm ² , 2 m	YM2A18-020UA5XLEAX	2095868
Male connector, M12, 8-pin, straight, A-coded, flying leads, 8 x 0.25 mm ² , 5 m	YM2A18-050UA5XLEAX	2095869
Male connector, M12, 8-pin, straight, A-coded, flying leads, 8 x 0.25 mm ² , 10 m	YM2A18-100UA5XLEAX	2095870
Female connector, M12, 5-pin, straight, A-coded, male connector, M12, 5-pin, straight, A-coded, 5 x 0.34 mm ² , 0.15 m	YF2A15-C15UB5M2A15	2096004
Female connector, M12, 5-pin, straight, A-coded, male connector, M12, 5-pin, straight, A-coded, 5 x 0.34 mm ² , 0.6 m	YF2A15-C60UB5M2A15	2096006
Female connector, M12, 5-pin, straight, A-coded, male connector, M12, 5-pin, straight, A-coded, 5 x 0.34 mm ² , 1 m	YF2A15-010UB5M2A15	2096007
Female connector, M12, 5-pin, straight, A-coded, male connector, M12, 5-pin, straight, A-coded, 5 x 0.34 mm ² , 1.5 m	YF2A15-015UB5M2A15	2096008
Female connector, M12, 5-pin, straight, A-coded, male connector, M12, 5-pin, straight, A-coded, 5 x 0.34 mm ² , 2 m	YF2A15-020UB5M2A15	2096009
Female connector, M12, 5-pin, straight, A-coded, male connector, M12, 5-pin, straight, A-coded, 5 x 0.34 mm ² , 5 m	YF2A15-050UB5M2A15	2096010
Female connector, M12, 5-pin, straight, A-coded, male connector, M12, 5-pin, straight, A-coded, 5 x 0.34 mm ² , 10 m	YF2A15-100UB5M2A15	2096011

Part	Type code	Part number
Female connector, M12, 5-pin, straight, A-coded, male connector, M12, 5-pin, straight, A-coded, 5 x 0.34 mm ² , 15 m	YF2A15-150UB5M2A15	2096171
Female connector, M12, 5-pin, straight, A-coded, male connector, M12, 5-pin, straight, A-coded, 5 x 0.34 mm ² , 20 m	YF2A15-200UB5M2A15	2095844
Female connector, M12, 5-pin, straight, A-coded, male connector, M12, 5-pin, straight, A-coded, 5 x 0.34 mm ² , 30 m	YF2A15-300UB5M2A15	2095845
Female connector, M12, 8-pin, straight, A-coded, male connector, M12, 8-pin, straight, A-coded, 8 x 0.25 mm ² , 0.6 m	YF2A18-C60UA5M2A18	2096031
Female connector, M12, 8-pin, straight, A-coded, male connector, M12, 8-pin, straight, A-coded, 8 x 0.25 mm ² , 1 m	YF2A18-010UA5M2A18	2096032
Female connector, M12, 8-pin, straight, A-coded, male connector, M12, 8-pin, straight, A-coded, 8 x 0.25 mm ² , 1.5 m	YF2A18-015UA5M2A18	2096012
Female connector, M12, 8-pin, straight, A-coded, male connector, M12, 8-pin, straight, A-coded, 8 x 0.25 mm ² , 2 m	YF2A18-020UA5M2A18	2096033
Female connector, M12, 8-pin, straight, A-coded, male connector, M12, 8-pin, straight, A-coded, 8 x 0.25 mm ² , 5 m	YF2A18-050UA5M2A18	2096034
Female connector, M12, 8-pin, straight, A-coded, male connector, M12, 8-pin, straight, A-coded, 8 x 0.25 mm ² , 10 m	YF2A18-100UA5M2A18	2096035
Female connector, M12, 5-pin, straight, A-coded, flying leads, 5 x 0.34 mm ² , 5 m	YF2A15-050UB5XLEAX	2095618
Female connector, M12, 5-pin, straight, A-coded, flying leads, 5 x 0.34 mm ² , 10 m	YF2A15-100UB5XLEAX	2095619
Female connector, M12, 5-pin, straight, A-coded, flying leads, 5 x 0.34 mm ² , 15 m	YF2A15-150UB5XLEAX	2095620
Female connector, M12, 5-pin, straight, A-coded, flying leads, 5 x 0.34 mm ² , 20 m	YF2A15-200UB5XLEAX	2095614
Male connector, M12, 5-pin, straight, A-coded, flying leads, 5 x 0.34 mm ² , 30 m	YF2A15-300UB5XLEAX	2095621
Adapter cable for male/female connector, male connector, M12, 5-pin to female connector, M26, 12-pin, 1 m	DSL-6182G01M034KM1	2072829

13.3 Mounting accessories

Table 67: Part numbers mounting accessories

Part	Part number
C-Fix bracket	2068830

14 Annex

14.1 Conformities and certificates

You can obtain declarations of conformity, certificates and the current documentation for the product at www.sick.com. To do so, enter the product part number in the search field (part number: see the entry in the “P/N” or “Ident. no.” field on the type label).

14.1.1 EU declaration of conformity

Excerpt

The undersigned, representing the manufacturer, herewith declares that the product is in conformity with the provisions of the following EU directive(s) (including all applicable amendments), and that the standards and/or technical specifications stated in the EU declaration of conformity have been used as a basis for this.

- ROHS DIRECTIVE 2011/65/EU
- EMC DIRECTIVE 2014/30/EU
- MACHINERY DIRECTIVE 2006/42/EC

14.1.2 UK declaration of conformity

Excerpt

The undersigned, representing the following manufacturer herewith declares that this declaration of conformity is issued under the sole responsibility of the manufacturer. The product of this declaration is in conformity with the provisions of the following relevant UK Statutory Instruments (including all applicable amendments), and the respective standards and/or technical specifications have been used as a basis.

- Restriction of the Use of Certain Hazardous Substances in Electrical and Electronic Equipment Regulations 2012
- Electromagnetic Compatibility Regulations 2016
- Supply of Machinery (Safety) Regulations 2008

14.2 Checklists

14.2.1 Checklist for initial commissioning and commissioning

Checklist for manufacturers/installers when installing the product

The details relating to the items listed below must be available no later than when the system is commissioned for the first time. However, these depend on the specific application (the requirements of which must be reviewed by the manufacturer or installer).

This checklist should be retained and kept with the machine documentation to serve as a reference during recurring thorough checks.

This checklist is not a substitute for initial commissioning or periodic thorough checks by qualified safety personnel.

Have the safety rules and regulations been observed in compliance with the directives and standards applicable to the machine?	Yes <input type="checkbox"/> No <input type="checkbox"/>
Are the applied directives and standards listed in the declaration of conformity?	Yes <input type="checkbox"/> No <input type="checkbox"/>
Does the protective device correspond to the required PL/SIL and PFHd in accordance with ISO 13849 / IEC 62061 and the required type in accordance with IEC 61496?	Yes <input type="checkbox"/> No <input type="checkbox"/>
Are the required protective measures against electric shock in effect (protection class)?	Yes <input type="checkbox"/> No <input type="checkbox"/>

Has the safety function been checked in compliance with the test notes of this documentation?	Yes <input type="checkbox"/> No <input type="checkbox"/>
Is it ensured that a complete test of the safety functions is done after any configuration change of the product?	Yes <input type="checkbox"/> No <input type="checkbox"/>

15 List of figures

1.	Flexi Loop safe series connection.....	10
2.	Error masking.....	11
3.	Subdivision of the safe series connection.....	12
4.	Supply of power.....	14
5.	Safe cut-off path.....	15
6.	Flexi Loop MSTR1 accessory on the Flexi Classic safety controller.....	16
7.	I/O functions of the Flexi Loop MSTR2 accessory.....	17
8.	IO-Link functions of the MSTR2 Flexi Loop accessory.....	18
9.	FLN-EMSS0000105.....	19
10.	FLN-EMSS1100108.....	19
11.	FLN-OSSD1000105.....	20
12.	FLN-OSSD1100108.....	20
13.	FLT-TERM00001.....	20
14.	FLA-PWRI00001.....	20
15.	FLA-MSTRO00001.....	20
16.	FLA-MSTRO00002.....	21
17.	FLA-DIAG00001.....	21
18.	FLA-YCON00001.....	21
19.	FLA-YCON00002.....	21
20.	LEDs of the Flexi Loop EMSS nodes.....	22
21.	LEDs of the Flexi Loop OSSD nodes.....	22
22.	LEDs of the PWRI power supply accessory.....	23
23.	LEDs for the Flexi Loop MSTR2 and DIAG accessories.....	23
24.	Direct connection to the voltage source of the programmable SICK safety controller.....	25
25.	Direct connection to the voltage source of the Flexi Classic safety controller.....	26
26.	Connection via the PWRI power supply accessory for the programmable SICK Flexi Soft or Flexi Compact safety controller.....	26
27.	Connection via the PWRI power supply accessory for the Flexi Classic safety controller.....	27
28.	Division into sections.....	27
29.	Reset using the programmable SICK safety controller.....	32
30.	Reset using the Flexi Classic safety controller.....	33
31.	Connection of a safety locking device to the EMSS node.....	34
32.	Lock using the programmable SICK safety controller.....	35
33.	Lock using the Flexi Classic safety controller.....	35
34.	Mounting in a cable channel.....	37
35.	Mounting with cable tie.....	37
36.	C-Fix bracket.....	38
37.	Mounting the Flex Loop node using a C-Fix bracket.....	38
38.	Connection to programmable SICK safety controller.....	40
39.	Connection example with Flexi Classic.....	41
40.	Connections of the Flexi Loop nodes.....	42
41.	Connecting the Flexi Loop nodes.....	43
42.	Connections of the EMSS Flexi Loop node.....	43
43.	Connection sketch dual-channel equivalent switch.....	44
44.	Connections of the OSSD Flexi Loop node.....	44
45.	Connections of the PWRI power supply accessory.....	45
46.	Connections of the MSTR1 Flexi Loop accessory.....	46
47.	Connections of the MSTR2 Flexi Loop accessory.....	47
48.	Connections of the DIAG Flexi Loop accessory.....	48
49.	Connection of Flexi Loop adapters.....	48
50.	Connections of the Flexi Loop YCON1 adapter.....	49
51.	Connections of the Flexi Loop YCON2 adapter.....	50

52.	Flexi Loop MSTR accessory with operating mode LED.....	52
53.	IODD commands and parameters.....	54
54.	Logical numbering of the Flexi Loop nodes.....	55
55.	MS LED.....	64
56.	MS LEDs direction indicator.....	65
57.	LEDs of the EMSS Flexi Loop nodes.....	66
58.	LEDs of the OSSD Flexi Loop nodes.....	67
59.	LEDs of the PWRI power supply accessory.....	67
60.	LEDs of the MSTR1 Flexi Loop accessory.....	68
61.	LEDs of the MSTR2 Flexi Loop accessory.....	69
62.	LEDs of the DIAG Flexi Loop accessory.....	71
63.	Observation Menu.....	73
64.	Test operations for the configuration.....	74
65.	Characteristic curve for PWRI power supply accessory.....	81
66.	Flexi Loop node dimensional drawing (mm).....	82
67.	PWRI power supply accessory dimensional drawing (mm).....	83
68.	Terminator dimensional drawing (mm).....	83
69.	C-Fix bracket dimensional drawing (mm).....	84
70.	FLA-MSTRO0001 Flexi Loop accessory dimensional drawing (mm).....	85
71.	FLA-MSTRO0002 Flexi Loop accessory dimensional drawing (mm).....	85
72.	DIAG Flexi Loop accessory dimensional drawing (mm).....	86
73.	FLA-YCON Flexi Loop connection adapter dimensional drawing (EMSS/OSSD)....	86

16 List of tables

1.	Available documents.....	6
2.	Target groups and selected sections of these operating instructions.....	6
3.	Indicators of the Flexi Loop EMSS nodes.....	22
4.	Indicators of the Flexi Loop OSSD nodes.....	22
5.	Indicators of the PWRI Flexi Loop accessory.....	23
6.	Indicators of the Flexi Loop MSTR and DIAG accessory.....	23
7.	Permissible total current within a section.....	24
8.	Example voltage drop on 10 Flexi Loop nodes.....	28
9.	Example voltage drop on 15 Flexi Loop nodes.....	29
10.	Example voltage drop on 15 Flexi Loop nodes with PWRI.....	29
11.	Example voltage drop on 15 Flexi Loop nodes with wire cross-section 0.75 mm ²	29
12.	Example voltage drop due to current consumption of connected devices.....	30
13.	Example voltage drop on 10 Flexi Loop nodes with PWRI.....	30
14.	Example voltage drop at 10 Flexi Loop nodes with wire cross-section 0.75 mm ²	30
15.	Pin assignment safety locking device to EMSS node.....	34
16.	Connection example with Flexi Soft.....	40
17.	Connection example with Flexi Classic.....	41
18.	Pin assignment FL_IN (male connector).....	42
19.	Pin assignment EMSS 5-pin (female connector).....	43
20.	Pin assignment EMSS 8-pin (female connector).....	44
21.	Pin assignment OSSD 5-pin (female connector).....	44
22.	Pin assignment OSSD 8-pin (female connector).....	45
23.	Pin assignment PWRI 5-pin (male connector).....	46
24.	Pin assignment FC_IN 8-pin (male connector).....	46
25.	Pin assignment FC_IN 8-pin (male connector).....	47
26.	Pin assignment for IO-Link or AUX_IN / AUX_OUT 5-pin (male connector).....	47
27.	Pin assignment FL_IN (male connector).....	48
28.	Pin assignment 8-pin EMSS (male connector).....	49
29.	5-pin AUX pin assignment (female connector).....	49
30.	Pin assignment EMSS 5-pin (female connector).....	50
31.	Pin assignment 8-pin OSSD (male connector).....	51
32.	5-pin AUX pin assignment (female connector).....	51
33.	Pin assignment OSSD 5-pin (female connector).....	51
34.	Displays of the MS LEDs.....	64
35.	EMSS LEDs and MS LED of the EMSS Flexi Loop nodes.....	66
36.	AUX_IN LED of the EMSS Flexi Loop nodes.....	66
37.	AUX_OUT LED of the EMSS Flexi Loop nodes.....	66
38.	OSSD LEDs and MS LED of the OSSD Flexi Loop nodes.....	67
39.	AUX_IN LED of the OSSD Flexi Loop nodes.....	67
40.	AUX_OUT LED of the OSSD Flexi Loop nodes.....	67
41.	PWR Right LED of the PWRI power supply accessory.....	68
42.	PWR Left LED of the PWRI power supply accessory.....	68
43.	Overload LED of the PWRI power supply accessory.....	68
44.	Node LEDs of the MSTR1 and MSTR2 Flexi Loop accessory.....	68
45.	Operating mode LED of the MSTR1 and MSTR2 Flexi Loop accessories.....	69
46.	Node LEDs of the MSTR1 and MSTR2 Flexi Loop accessory.....	70
47.	Operating mode LED of the MSTR1 and MSTR2 Flexi Loop accessories.....	70
48.	IO-Link LED of the MSTR2 Flexi Loop accessory.....	70
49.	Node LEDs for the Flexi Loop DIAG accessory.....	71
50.	Operating mode LED of the DIAG Flexi Loop accessory.....	71
51.	Loop integrity LED on the DIAG Flexi Loop accessory.....	72
52.	Safety-related parameters.....	77
53.	Flexi Loop nodes and Flexi Loop accessories data sheet.....	77
54.	Data sheet for Flexi Loop EMSS nodes.....	79

55. Additional data for 8-pin variant FLN-EMSS1100108.....	79
56. Data sheet OSSD Flexi Loop node.....	80
57. Additional data for 8-pin FLN-OSSD1100108 variant.....	80
58. Data sheet FLT-TERM00001 terminator.....	80
59. Data sheet PWRI power supply accessory.....	80
60. Data sheet MSTR Flexi Loop accessory.....	81
61. Additional data for FLA-MSTR00002 variant with IO-Link interface.....	82
62. Compatibility.....	87
63. Ordering information for Flexi Loop nodes.....	88
64. Ordering information for Flexi Loop accessories.....	88
65. Part numbers plug connectors.....	90
66. Part numbers pre-assembled cables.....	90
67. Part numbers mounting accessories.....	91

Australia

Phone +61 (3) 9457 0600
1800 33 48 02 – tollfree
E-Mail sales@sick.com.au

Austria

Phone +43 (0) 2236 62288-0
E-Mail office@sick.at

Belgium/Luxembourg

Phone +32 (0) 2 466 55 66
E-Mail info@sick.be

Brazil

Phone +55 11 3215-4900
E-Mail comercial@sick.com.br

Canada

Phone +1 905.771.1444
E-Mail cs.canada@sick.com

Czech Republic

Phone +420 234 719 500
E-Mail sick@sick.cz

Chile

Phone +56 (2) 2274 7430
E-Mail chile@sick.com

China

Phone +86 20 2882 3600
E-Mail info.china@sick.net.cn

Denmark

Phone +45 45 82 64 00
E-Mail sick@sick.dk

Finland

Phone +358-9-25 15 800
E-Mail sick@sick.fi

France

Phone +33 1 64 62 35 00
E-Mail info@sick.fr

Germany

Phone +49 (0) 2 11 53 010
E-Mail info@sick.de

Greece

Phone +30 210 6825100
E-Mail office@sick.com.gr

Hong Kong

Phone +852 2153 6300
E-Mail ghk@sick.com.hk

Hungary

Phone +36 1 371 2680
E-Mail ertekebsites@sick.hu

India

Phone +91-22-6119 8900
E-Mail info@sick-india.com

Israel

Phone +972 97110 11
E-Mail info@sick-sensors.com

Italy

Phone +39 02 27 43 41
E-Mail info@sick.it

Japan

Phone +81 3 5309 2112
E-Mail support@sick.jp

Malaysia

Phone +603-8080 7425
E-Mail enquiry.my@sick.com

Mexico

Phone +52 (472) 748 9451
E-Mail mexico@sick.com

Netherlands

Phone +31 (0) 30 204 40 00
E-Mail info@sick.nl

New Zealand

Phone +64 9 415 0459
0800 222 278 – tollfree
E-Mail sales@sick.co.nz

Norway

Phone +47 67 81 50 00
E-Mail sick@sick.no

Poland

Phone +48 22 539 41 00
E-Mail info@sick.pl

Romania

Phone +40 356-17 11 20
E-Mail office@sick.ro

Singapore

Phone +65 6744 3732
E-Mail sales.gsg@sick.com

Slovakia

Phone +421 482 901 201
E-Mail mail@sick-sk.sk

Slovenia

Phone +386 591 78849
E-Mail office@sick.si

South Africa

Phone +27 10 060 0550
E-Mail info@sickautomation.co.za

South Korea

Phone +82 2 786 6321/4
E-Mail infokorea@sick.com

Spain

Phone +34 93 480 31 00
E-Mail info@sick.es

Sweden

Phone +46 10 110 10 00
E-Mail info@sick.se

Switzerland

Phone +41 41 619 29 39
E-Mail contact@sick.ch

Taiwan

Phone +886-2-2375-6288
E-Mail sales@sick.com.tw

Thailand

Phone +66 2 645 0009
E-Mail marcom.th@sick.com

Turkey

Phone +90 (216) 528 50 00
E-Mail info@sick.com.tr

United Arab Emirates

Phone +971 (0) 4 88 65 878
E-Mail contact@sick.ae

United Kingdom

Phone +44 (0)17278 31121
E-Mail info@sick.co.uk

USA

Phone +1 800.325.7425
E-Mail info@sick.com

Vietnam

Phone +65 6744 3732
E-Mail sales.gsg@sick.com

Detailed addresses and further locations at www.sick.com

