

OPERATING INSTRUCTIONS

M4000 Standard and  
M4000 Standard A/P

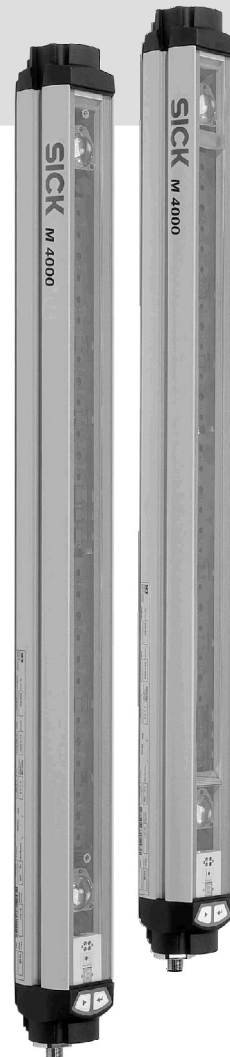

Multiple Light Beam Safety Device



en

**SICK**  
Sensor Intelligence.

This document is protected by the law of copyright, whereby all rights established therein remain with the company SICK AG. Reproduction of this document or parts of this document is only permissible within the limits of the legal determination of Copyright Law. Alteration or abridgement of the document is not permitted without the explicit written approval of the company SICK AG.



**Contents**

<b>1</b>	<b>About this document.....</b>	<b>6</b>
1.1	Function of this document.....	6
1.2	Target group .....	6
1.3	Depth of information.....	6
1.4	Scope .....	7
1.5	Abbreviations and terms.....	7
1.6	Symbols used .....	8
<b>2</b>	<b>On safety.....</b>	<b>9</b>
2.1	Qualified safety personnel.....	9
2.2	Applications of the device.....	9
2.3	Correct use .....	10
2.4	General safety notes and protective measures .....	10
2.5	Environmental protection .....	11
2.5.1	Disposal .....	11
2.5.2	Separation of materials .....	11
<b>3</b>	<b>Product description.....</b>	<b>12</b>
3.1	Special features .....	12
3.2	Operating principle of the device .....	13
3.2.1	The principle of the multiple light beam safety device .....	13
3.2.2	Device components .....	13
3.3	Application examples.....	15
3.3.1	Access protection.....	15
3.3.2	Access protection on several sides with the aid of deflector mirrors .....	16
3.4	Controls and status indicators .....	17
3.4.1	Configuration buttons .....	17
3.4.2	End cap with integrated LED (optional, only on receiver).....	18
3.4.3	Status indicators of the sender.....	19
3.4.4	Status indicators of the receiver or of the M4000 Standard A/P .....	20
<b>4</b>	<b>Configurable functions .....</b>	<b>21</b>
4.1	Restart interlock.....	21
4.2	Beam coding.....	23
4.3	Application diagnostic output (ADO) .....	24
4.4	Scanning range .....	24
4.4.1	Scanning range of the M4000 Standard.....	25
4.4.2	Scanning range of the M4000 Standard A/P .....	26
4.5	External device monitoring (EDM).....	27
4.6	Sender test .....	28
4.7	M4000 with integrated interface for AS-Interface Safety at Work (optional).....	29
4.7.1	The principle of the AS-Interface Safety at Work.....	29
4.7.2	Principle of operation of the M4000 with integrated AS-Interface .....	30
4.7.3	Functions that can be configured on the use of the M4000 with integrated interface for AS-Interface Safety at Work .....	30
4.7.4	Replacing a M4000 with integrated AS-Interface .....	30

<b>5</b>	<b>Mounting</b> .....	<b>31</b>
5.1	Calculation of the minimum distance .....	31
5.1.1	Minimum distance to the hazardous area .....	32
5.1.2	Minimum distance to reflective surfaces.....	35
5.1.3	Minimum distance for the M4000 with integrated AS-Interface.....	37
5.2	Steps for mounting the device.....	38
5.2.1	Mounting with Omega bracket.....	39
5.2.2	Mounting with swivel mount bracket.....	40
5.2.3	Mounting with side bracket.....	42
5.2.4	Mounting with rigid mounting bracket .....	44
5.2.5	Mounting with pivoting mounting bracket.....	46
<b>6</b>	<b>Electrical installation</b> .....	<b>48</b>
6.1	System connection M12 × 7 + FE .....	50
6.2	Optional connections.....	51
6.2.1	AS-Interface connection M12 × 4.....	51
6.2.2	Connection Reset M12 × 5 .....	51
6.3	External device monitoring (EDM) .....	52
6.4	Reset button/restart button.....	52
6.5	Application diagnostic output (ADO).....	54
6.6	Test input (sender test) .....	55
<b>7</b>	<b>Commissioning</b> .....	<b>56</b>
7.1	Display sequence during start-up.....	56
7.2	Commissioning the M4000 with integrated AS-Interface Safety at Work in AS-Interface network .....	56
7.3	Alignment of the M4000 .....	57
7.3.1	Meaning of the 7-segment display during alignment .....	58
7.3.2	Aligning sender and receiver .....	60
7.3.3	Special aspects of alignment with deflector mirrors .....	60
7.3.4	Alignment of the M4000 Standard with integrated laser alignment aid (optional) .....	61
7.4	Test notes.....	66
7.4.1	Pre-commissioning test notes.....	66
7.4.2	Regular inspection of the protective device by qualified safety personnel .....	66
7.4.3	Daily functional checks of the protective device .....	67
<b>8</b>	<b>Configuration</b> .....	<b>69</b>
8.1	Default delivery status.....	69
8.2	Preparation of the configuration.....	69
8.3	Configuration of the M4000 .....	70
8.3.1	Opening the configuration mode .....	70
8.3.2	Configure the required functions.....	71
8.3.3	Saving the configuration .....	73
<b>9</b>	<b>Care and maintenance</b> .....	<b>74</b>
<b>10</b>	<b>Fault diagnosis</b> .....	<b>75</b>
10.1	In the event of faults or errors .....	75
10.2	SICK support.....	75
10.3	Error displays of the LEDs.....	76
10.4	Error displays of the 7-segment display .....	76

<b>11</b>	<b>Technical specifications</b>	<b>79</b>
11.1	Data sheet	79
11.1.1	M4000 Standard and M4000 Standard A/P	79
11.1.2	M4000 Standard and M4000 Standard A/P with integrated AS-Interface Safety at Work interface	83
11.2	Table of weights	85
11.2.1	M4000 Standard	85
11.2.2	M4000 Passive	85
11.3	Dimensional drawings	86
11.3.1	M4000 Standard, M4000 Standard A/P	86
11.3.2	M4000 Passive	88
11.3.3	Omega bracket	89
11.3.4	Swivel mount bracket	90
11.3.5	Side bracket	90
11.3.6	Rigid mounting bracket	91
11.3.7	Pivoting mounting bracket	91
11.3.8	Deflector mirror PNS75-008	92
11.3.9	Deflector mirror PSK45	93
<b>12</b>	<b>Ordering information</b>	<b>94</b>
12.1	M4000 Standard	94
12.1.1	Delivery	94
12.1.2	Part numbers	94
12.1.3	Default delivery status	95
12.2	M4000 Standard A/P	96
12.2.1	Delivery	96
12.2.2	Type code	96
12.2.3	Default delivery status	97
12.3	Additional options	97
12.4	Additional front screen (weld spark guard)	99
12.5	Deflector mirrors and mirror columns	100
12.6	Device columns	100
12.7	Accessories	101
<b>13</b>	<b>Annex</b>	<b>103</b>
13.1	Compliance with EU directives	103
13.2	Checklist for the manufacturer	104
13.3	Alignment templates	105
13.4	Alignment instructions	107
13.5	List of tables	109
13.6	List of illustrations	111

# 1 About this document

Please read this chapter carefully before working with this documentation and the M4000 multiple light beam safety device.

## 1.1 Function of this document

These operating instructions are designed to address *the technical personnel of the machine manufacturer* or the *machine operator* in regards to safe mounting, installation, configuration, electrical installation, commissioning, operation and maintenance of the M4000 multiple light beam safety device.

These operating instructions do *not* provide instructions for operating machines on which the multiple light beam safety device is, or will be, integrated. Information on this is to be found in the appropriate operating instructions for the machine.

## 1.2 Target group

These operating instructions are addressed to *planning engineers, machine designers* and *operators* of plants and systems which are to be protected by one or several M4000 multiple light beam safety devices. It also addresses people who integrate the M4000 multiple light beam safety device into a machine, initialise its use, or who are in charge of servicing and maintaining the device.

## 1.3 Depth of information

These operating instructions contain the following information on the M4000 multiple light beam safety device:

- mounting
- electrical installation
- commissioning and configurable functions
- care and maintenance
- fault diagnosis and troubleshooting
- part numbers
- conformity and approval

Planning and using protective devices such as the M4000 multiple light beam safety device also require specific technical skills which are not detailed in this documentation.

When operating the M4000 multiple light beam safety device, the national, local and statutory rules and regulations must be observed.

General information on accident prevention using opto-electronic protective devices can be found in the SICK brochure "Safe Machines with opto-electronic protective devices".

**Note** We also refer you to the SICK homepage on the Internet at [www.sick.com](http://www.sick.com).

Here you will find information on:

- sample applications
- a list of frequently asked questions regarding the M4000
- these operating instructions in different languages for viewing and printing
- EU Declaration of Conformity

## 1.4 Scope

These operating instructions are original operating instructions.

**Note** These operating instructions are applicable to the multiple light beam safety devices M4000 Standard and M4000 Standard A/P with one of the following entries on the type label in the field *Operating Instructions*:

- 8011190\_WP69
- 8011190\_YT81

This document is part of SICK part number 8011190 (operating instructions “M4000 Standard and M4000 Standard A/P – Multiple Light Beam Safety Device” in all available languages).

## 1.5 Abbreviations and terms

<b>ADO</b>	Application diagnostic output = configurable signal output that indicates a specific status of the protective device
<b>AS-Interface</b>	Actuator-Sensor-Interface = established system for networking primarily binary sensors and actuators at the lowest level of the automation hierarchy
<b>AS-Interface Safety at Work</b>	Extension of the AS-Interface system with safety-related components by using a combination of AS-Interface safety monitors and safe AS-Interface bus nodes
<b>AS-Interface safety monitor</b>	One of more safety monitors integrated into the AS-Interface system monitor the states of the safe AS-Interface bus nodes and shut down the dangerous state as necessary
<b>Beam separation</b>	Distance between two neighbouring beams, measured from the middle of one beam to the middle of the other.
<b>EDM</b>	External device monitoring
<b>ESPE</b>	Electro-sensitive protective equipment (e.g. M4000)
<b>OSSD</b>	Output signal switching device
<b>OWS</b>	Output weak signal = contamination signal
<b>PLC</b>	Programmable logic controller

## 1.6 Symbols used

### Recommendation

Recommendations are designed to give you some assistance in your decision-making process with respect to a certain function or a technical measure.

### Note

Refer to notes for special features of the device.

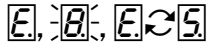

Display indications show the status of the 7-segment display on sender or receiver:

- Constant display of the letter E
- Flashing display of the digit 8
- Alternating display of E and 5



LED symbols describe the status of an LED:

- The LED is constantly illuminated.
- The LED is flashing.
- The LED is off.

### ➤ Take action ...

Instructions for taking action are shown by an arrow. Read carefully and follow the instructions for action.



WARNING

### Warning!

A warning indicates an actual or potential risk or health hazard. Observation and implementation of the warning will protect you from accidents.

Read carefully and follow the warning notices!



Configuration instructions show you that you can make the related setting with the aid of the configuration buttons and where you will find the related procedure.



### Configuration buttons Select and Enter

The symbol designates the configuration button *Select*. The symbol designates the configuration button *Enter*.



### Sender and receiver

In drawings and diagrams, the symbol denotes the sender and the symbol denotes the receiver.

### The term “dangerous state”

The dangerous state (standard term) of the machine is always shown in the drawings and diagrams of this document as a movement of a machine part. In practical operation, there may be a number of different dangerous states:

- machine movements
- electrical conductors
- visible or invisible radiation
- a combination of several risks and hazards



## 2 On safety

This chapter deals with your own safety and the safety of the equipment operators.

- Please read this chapter carefully before working with the M4000 multiple light beam safety device or with the machine protected by the M4000 multiple light beam safety device.

### 2.1 Qualified safety personnel

The M4000 multiple light beam safety device must only be installed, commissioned and serviced by qualified safety personnel. Qualified safety personnel are defined as persons who

- have undergone the appropriate technical training

**and**

- who have been instructed by the responsible machine operator in the operation of the machine and the current valid safety guidelines

**and**

- who have access to these operating instructions.

### 2.2 Applications of the device

The M4000 system is a type 4 electro-sensitive protective equipment (ESPE) as defined by IEC 61496-1 and IEC 61496-2 and is therefore allowed for use with controls in category 4 according to EN ISO 13849-1. The M4000 multiple light beam safety device is used for:

- hazardous area protection
- access protection

The multiple light beam safety devices must be installed such that the hazardous area can only be reached by interrupting the light path between sender and receiver. It must not be possible to start the plant/system as long as personnel are within the hazardous area.

The M4000 system is intended only for use in industrial environments. When used in residential areas it can cause interference.

Please refer to page 15 for an illustration of the protection modes and an example application.



WARNING

---

**Only use the multiple light beam safety device as an indirect protective measure!**

An opto-electronic protective device like the M4000 system cannot provide any protection against parts thrown out or against radiation. Transparent objects are not detected.

---

Depending on the application, mechanical protective devices may be required in addition to the M4000 system.

## 2.3 Correct use

The M4000 system must be used only as defined in chapter 2.2 “Applications of the device”. It must be used only by qualified personnel and only on the machine where it has been installed and initialised by qualified safety personnel in accordance with these operating instructions.

All warranty claims against SICK AG are forfeited in the case of any other use, or alterations being made to the system, even as part of their mounting or installation.

## 2.4 General safety notes and protective measures



WARNING

### Safety notes

Please observe the following items in order to ensure the correct and safe use of the M4000 multiple light beam safety device.

- The national/international rules and regulations apply to the installation, commissioning, use and periodic technical inspections of the multiple light beam safety device, in particular ...
  - Machinery Directive
  - Work Equipment Directive
  - the work safety regulations/safety rules
  - other relevant safety regulations

Manufacturers and operators of the machine on which the multiple light beam safety device is used are responsible for obtaining and observing all applicable safety regulations and rules.

- The notices, in particular the test regulations (see “Test notes” on page 66) of these operating instructions (e.g. on use, mounting, installation or integration into the existing machine controller) must be observed.
- Changes to the configuration of the devices can degrade the protective function. After every change to the configuration you must therefore check the effectiveness of the protective device.

The person who makes the change is also responsible for the correct protective function of the device. When making configuration changes, please always use a password to ensure that only authorised persons make changes to the configuration. The SICK service team is available to provide assistance if required.

- The tests must be carried out by qualified safety personnel or specially qualified and authorised personnel and must be recorded and documented to ensure that the tests can be reconstructed and retraced at any time.
- The operating instructions must be made available to the operator of the machine where the M4000 multiple light beam safety device is fitted. The machine operator is to be instructed in the use of the device by qualified safety personnel and must be instructed to read the operating instructions.
- The external voltage supply of the devices must be capable of buffering brief mains voltage failures of 20 ms as specified in EN 60204-1. Suitable power supplies are available as accessories from SICK (Siemens type series 6 EP 1). On devices with an integrated interface for AS-Interface Safety at Work, the voltage supply must also comply with the AS-Interface specification. Suitable power supplies are available as accessories from SICK (Puls, type series SLA 3/SLA 8).

**2.5 Environmental protection**

The M4000 multiple light beam safety device is constructed in such a way that it adversely affects the environment as little as possible. It uses only a minimum of power and natural resources.

➤ At work, always act in an environmentally responsible manner.

**2.5.1 Disposal**

Unusable or irreparable devices should always be disposed as per the applicable national regulations on waste disposal (e.g. European waste code 16 02 14).

**Notes**

- We would be pleased to be of assistance on the disposal of this device. Contact your local SICK representative.
- Information on the individual materials in the M4000 is given in chapter 11 “Technical specifications” on page 82.

**2.5.2 Separation of materials**



WARNING

**Only appropriately trained personnel are allowed to separate materials!**

Caution is required when dismantling devices. There is a risk of injuries.

Before you send the devices for appropriate recycling, it is necessary to separate the different materials in the M4000.

- Separate the housing from the rest of the parts (in particular the circuit board).
- Send the separated parts for recycling as appropriate (see Tab. 1).

Tab. 1: Overview on disposal by components

Components	Disposal
Product	
Housing	Metal recycling (aluminium)
Circuit boards, cable, connector and electrical connecting pieces	Electronic recycling
Packaging	
Cardboard, paper	Paper/cardboard recycling
Polyethylene packaging	Plastic recycling

## 3 Product description

This chapter provides information on the special features and properties of the M4000 multiple light beam safety device. It describes the construction and the operating principle of the device.

➤ Please read this chapter before mounting, installing and commissioning the device.

### 3.1 Special features

#### Properties of all devices described in these operating instructions

- protective operation with either internal or external (realised on the machine) restart interlock
- configuration buttons
- external device monitoring (EDM)
- beam coding
- configurable application diagnostic output (ADO)
- status display with 7-segment display
- integrated interface for AS-Interface Safety at Work (optional)
- reset, connection for the reset button either in the control cabinet or directly to the device (optional)
- end cap with integrated LED (optional)

#### M4000 Standard

- 2, 3 or 4 beams
- scanning range up to 70 m
- integrated laser alignment aid (optional)

#### M4000 Standard A/P

- less wiring costs: Only one device needs to be connected electrically.
- quick and straightforward alignment in conjunction with the M4000 Passive (deflector unit)
- 2 beams, scanning range to 7.5 m (M4000 Passive with mirror deflection)
- 2 or 4 beams, scanning range to 4.5 m (M4000 Passive with fibre-optic deflection)

**3.2 Operating principle of the device**

**3.2.1 The principle of the multiple light beam safety device**

The M4000 multiple light beam safety device secures the access to a hazardous area and signals the entry of objects as soon as a light beam is interrupted. The machine or plant controller that evaluates this message must then bring the dangerous movement to a halt. You can secure two sides of a hazardous area by using a deflector mirror, with two deflector mirrors you can secure three sides (see section 3.3.2 “Access protection on several sides with the aid of deflector mirrors” on page 16ff.).

**3.2.2 Device components**

Fig. 1: Components of the M4000 Standard

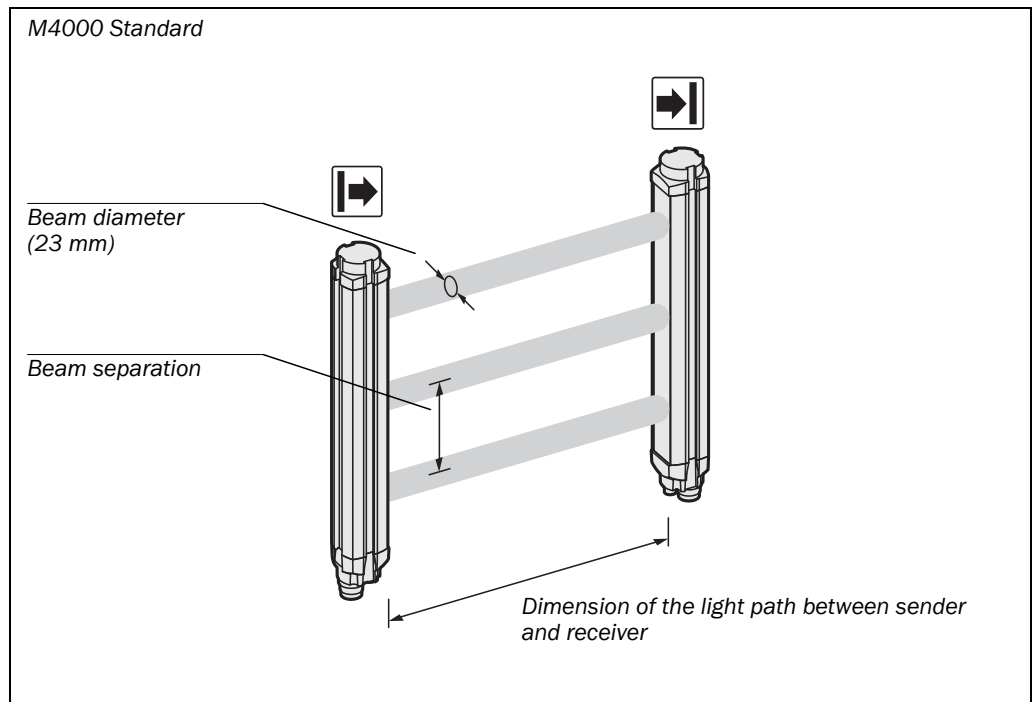
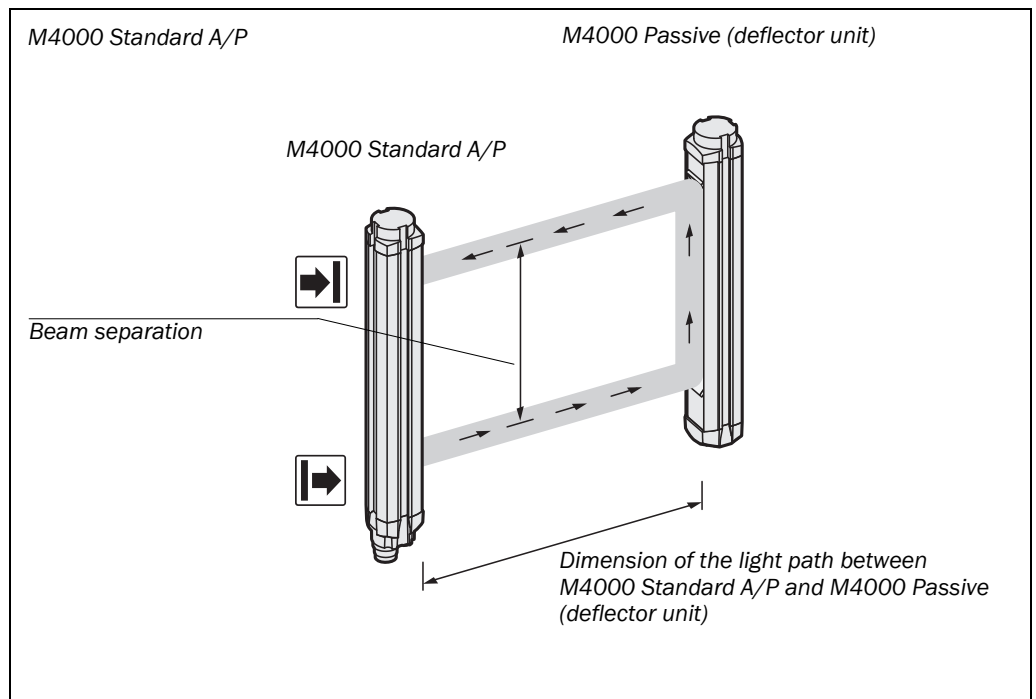

Fig. 2: Components of the M4000 Standard A/P



**Principles of operation**

The M4000 multiple light beam safety device consists of a sender unit and a receiver unit. A distinction should be made between active/active systems and active/passive systems:

- On the active/active system, sender unit and receiver unit are in separate housings, the *sender* and the *receiver*. The light beam is emitted from the sender and is incident to the receiver.
- On the active/passive system, sender unit and receiver unit are in a common housing (*M4000 Standard A/P*). The light beam is emitted from the sender unit and is deflected by the deflector unit *M4000 Passive* (mirror deflection or fibre-optic deflection) by 180° back to the receiver unit (see Fig. 2). As a passive element, the deflector unit does not require any electrical connections.

For the exact number and distance of beams, please see chapter 11.3 “Dimensional drawings” on page 86ff.

The dimension of the light path between sender and receiver (or between *M4000 Standard A/P* and *M4000 Passive*) must not exceed the maximum permissible scanning range (see “Technical specifications” on page 79ff.).

On active/active systems, sender unit and receiver unit synchronise automatically by optical means. An electrical connection between both components is not required.

The M4000 is modular in structure. All optical and electronic components and assemblies are housed in a slim and torsionally rigid housing.

**M4000 Standard**

The M4000 Standard multiple light beam safety device is available with 2, 3 or 4 beams. Other configurations with up to 12 beams are possible on request. The maximum scanning range (dimension of the light path between sender and receiver) is 70 m.

**M4000 Standard A/P**

The M4000 Standard A/P is available with 2 or 4 beams. The maximum scanning range (dimension of the light path between *M4000 Standard A/P* and *M4000 Passive*) is dependent on the number of beams as well as the *M4000 Passive* used and is max. 7.5 m.

### 3.3 Application examples

#### 3.3.1 Access protection

Fig. 3: Access protection with a M4000 Standard multiple light beam safety device

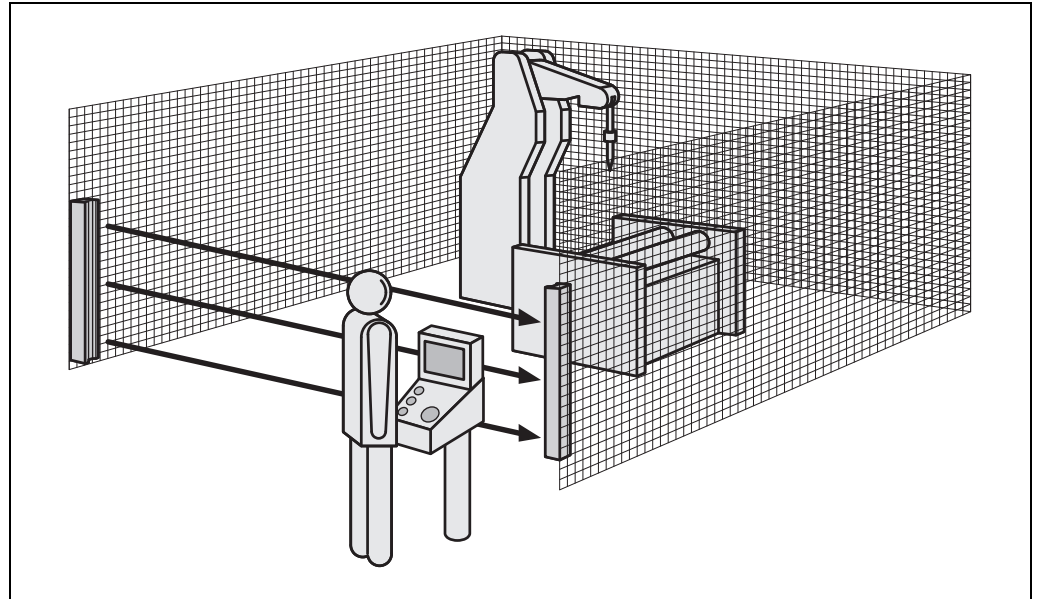
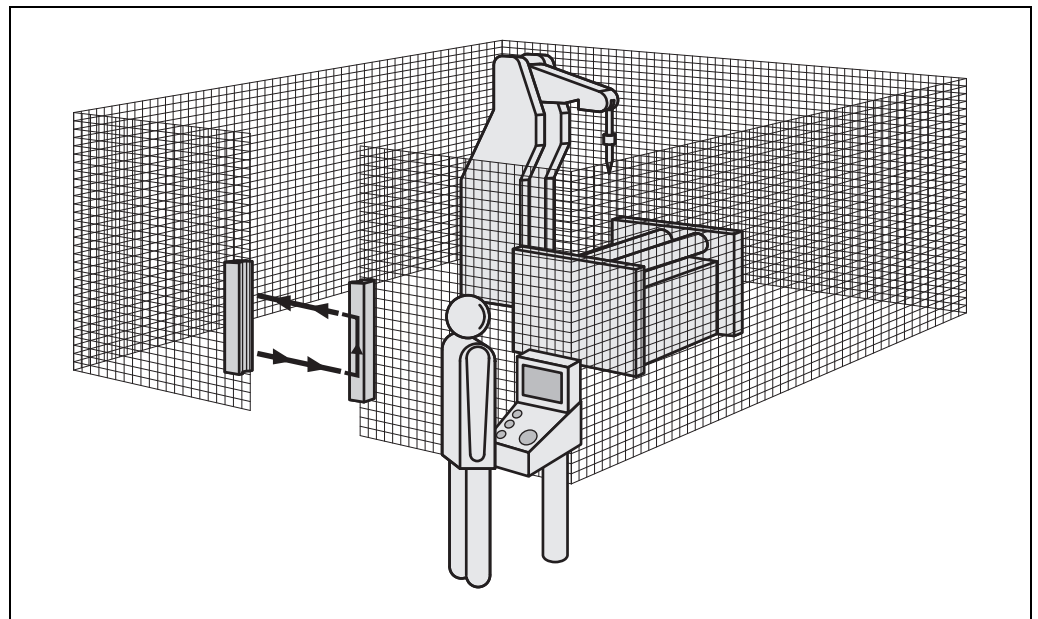

Fig. 4: Access protection with a M4000 Standard A/P multiple light beam safety device



The M4000 multiple light beam safety device operates correctly as a protective device only if the following conditions are met:

- The control of the machine must be electrical.
- It must be possible to achieve a safe state on the machine at any time.
- Sender and receiver must be mounted in a way that objects penetrating the hazardous area are safely identified by the M4000.
- The reset button must be fitted outside the hazardous area such that it cannot be operated by a person working inside the hazardous area. When operating the reset button, the operator must have full visual command of the hazardous area.
- The statutory and local rules and regulations must be observed when installing and using the device.

### 3.3.2 Access protection on several sides with the aid of deflector mirrors

You can secure two sides of a hazardous area by using a deflector mirror (see Fig. 5), with two deflector mirrors you can secure three sides (see Fig. 6).

Fig. 5: Access protection with a M4000 Standard multiple light beam safety device and one deflector mirror

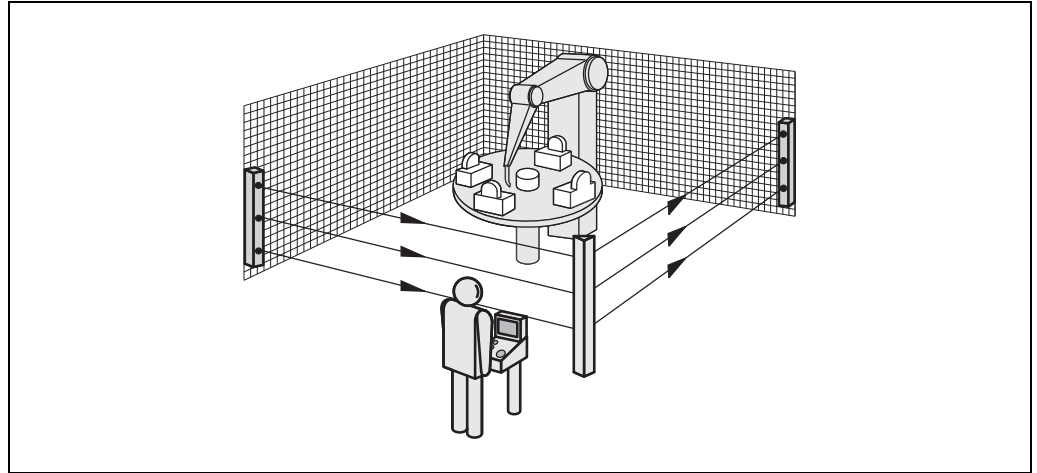

Fig. 6: Access protection with a M4000 Standard multiple light beam safety device and two deflector mirrors

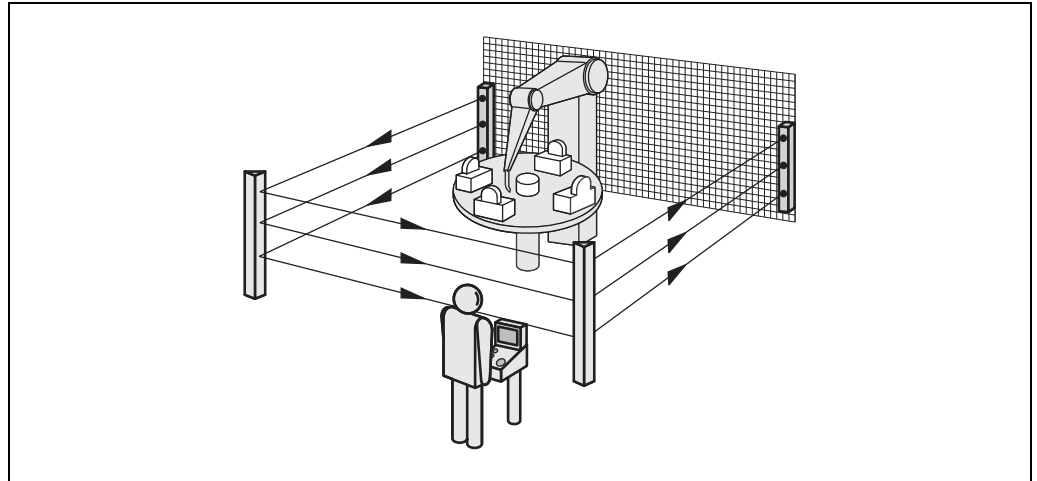
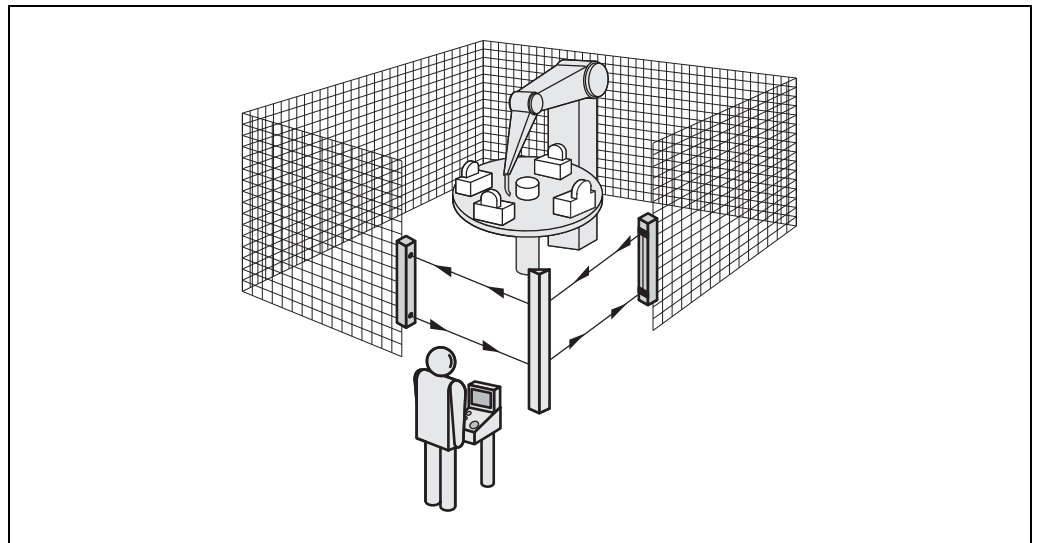

Fig. 7: Access protection with an M4000 Standard A/P multiple light beam safety device and one deflector mirror





- Notes**
- The formation of droplets of heavy contamination can be detrimental to the reflection behaviour. Take the necessary organisational measures to avoid the formation of droplets on the deflector mirrors. The deflector mirrors are available as accessories (see page 100f.).
  - Deflector mirrors reduce the effective scanning range. The effective scanning range depends on the number of deflector mirrors in the light path (see chapter 4.4 “Scanning range” on page 24ff).
  - You can extend the M4000 Standard A/P multiple light beam safety device with a maximum of one deflector mirror.

### 3.4 Controls and status indicators

The configuration buttons are used for setting the device functions. The LEDs and the 7-segment display of sender and receiver signal the operating status of the M4000.

#### 3.4.1 Configuration buttons

Fig. 8: Configuration buttons of the M4000 multiple light beam safety device

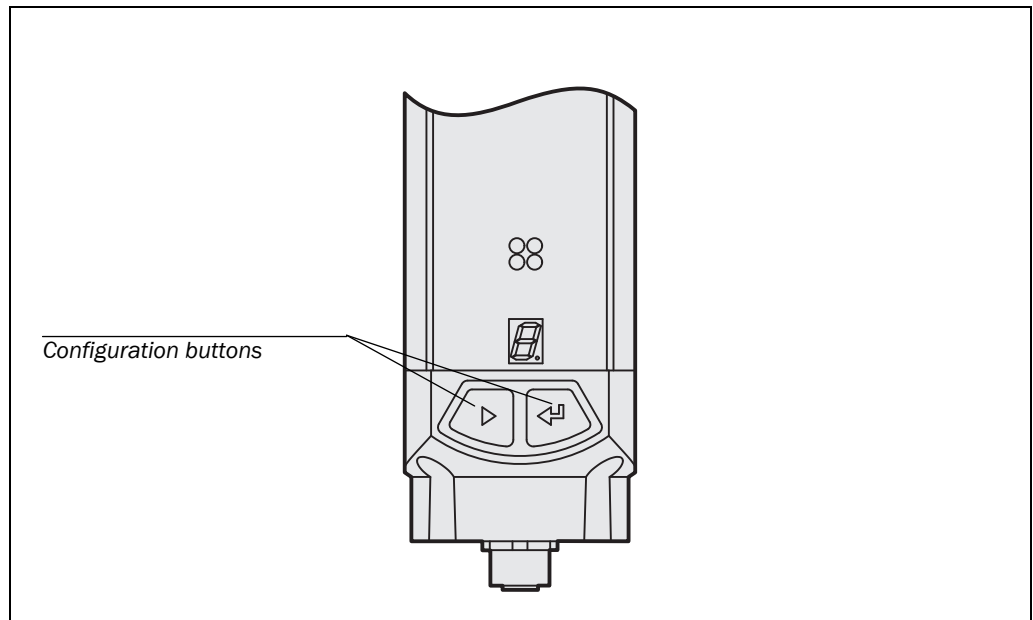

Tab. 2: Meaning of the configuration buttons

Button	Meaning
▶ Selection	Select function or setting Please refer to chapter 8.3 “Configuration of the M4000” on page 70.
◀ Enter	Confirm selection Please refer to chapter 8.3 “Configuration of the M4000” on page 70.

### 3.4.2 End cap with integrated LED (optional, only on receiver)

**Note** The integrated LED is not monitored. This means that a failure of the integrated LED has no effect on the function of the M4000.

Fig. 9: End cap with integrated LED

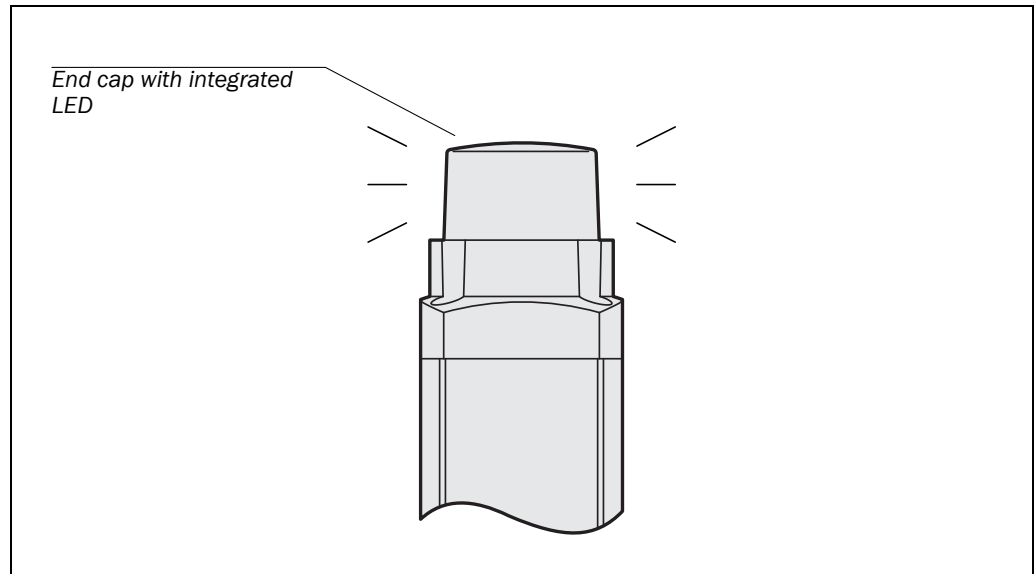

Tab. 3: Significance of the indications on the integrated LED

Indications on the integrated LED	Meaning
● Red	<p>System providing signals for shutting down the machine: Output signal switching devices off</p> <p><b>Or:</b></p> <p>A code table with the bit sequence 0000 is present at the integrated AS-Interface Safety at Work interface (on devices with integrated AS-Interface Safety at Work interface).</p>
● Green	<p>System clear: Output signal switching devices on</p> <p><b>Or:</b></p> <p>A unique code table is present at the integrated AS-Interface Safety at Work interface (on devices with integrated AS-Interface Safety at Work interface).</p>

## M4000 Std., Std. A/P

### 3.4.3 Status indicators of the sender

Fig. 10: Status indicators of the sender

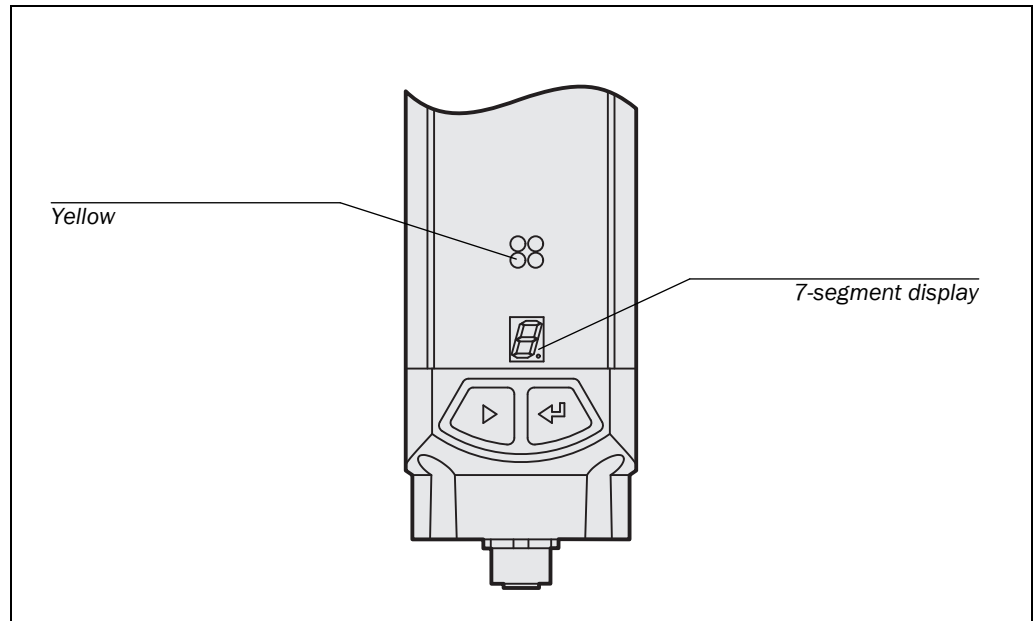

Tab. 4: Meaning of the status indicators of the sender

Display	Meaning
● Yellow	Supply voltage o.k.
	System error. Disconnect the supply voltage to the M4000 for at least 3 seconds. If the problem persists, replace the unit.
	The device is in the test mode.
	Non-coded operation (only after switching on)
	Operation with code 1 (only after switching on)
	Operation with code 2 (only after switching on)
Other displays	All other displays are error messages. Please refer to chapter 10 "Fault diagnosis" on page 75.

## 3.4.4 Status indicators of the receiver or of the M4000 Standard A/P

Fig. 11: Status indicators of the receiver or of the M4000 Standard A/P

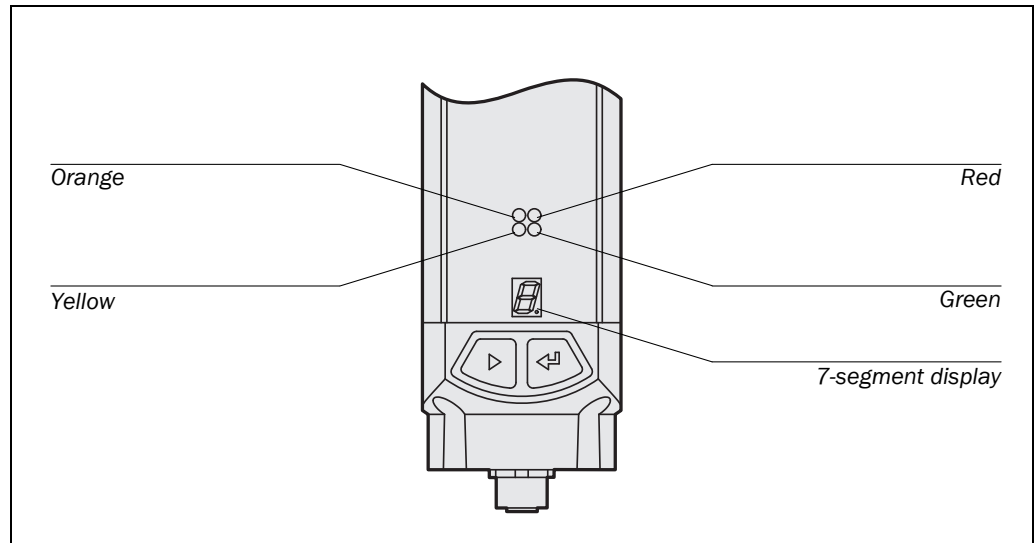

Tab. 5: Meaning of the status indicators of the receiver

Display	Meaning
● Orange	Cleaning or realignment required
● Yellow	Reset required
● Red	System providing signals for shutting down the machine: output signal switching devices off <b>Or:</b> A code table with the bit sequence 0000 is present at the integrated AS-Interface Safety at Work interface (on devices with integrated AS-Interface Safety at Work interface).
● Green	System clear: output signal switching devices on <b>Or:</b> A unique code table is present at the integrated AS-Interface Safety at Work interface (on devices with integrated AS-Interface Safety at Work interface).
	System error. Disconnect the supply voltage to the M4000 for at least 3 seconds. If the problem persists, replace the unit.
	Temporary AS-Interface error (only on devices with integrated AS-Interface Safety at Work) Please refer to chapter 10 "Fault diagnosis" on page 75.
	Poor alignment to sender
	Please refer to chapter 7.3 "Alignment of the M4000" on page 57.
	Note: In normal operation, the display  indicates the state "The light path is interrupted".
	Operation with large scanning range (only after switching on)
	Non-coded operation (only after switching on)
	Operation with code 1 (only after switching on)
	Operation with code 2 (only after switching on)
Other displays	All other displays are error messages. Please refer to chapter 10 "Fault diagnosis" on page 75.

## 4 Configurable functions

This chapter describes the functions on the M4000 multiple light beam safety device that can be set with the configuration buttons. Some of the functions can be combined.



WARNING

### Test the protective device after any changes!

The entire protective device must be tested for correct operation after each change of the configuration (see 7.4 on page 66).

**Note** When you use the M4000 multiple light beam safety device with integrated AS-Interface Safety at Work, you can only set certain device functions using the configuration button. Details can be found in chapter 4.7.3 “Functions that can be configured on the use of the M4000 with integrated interface for AS-Interface Safety at Work” on page 30.

### 4.1 Restart interlock

Fig. 12: Schematic illustration of the protective operation

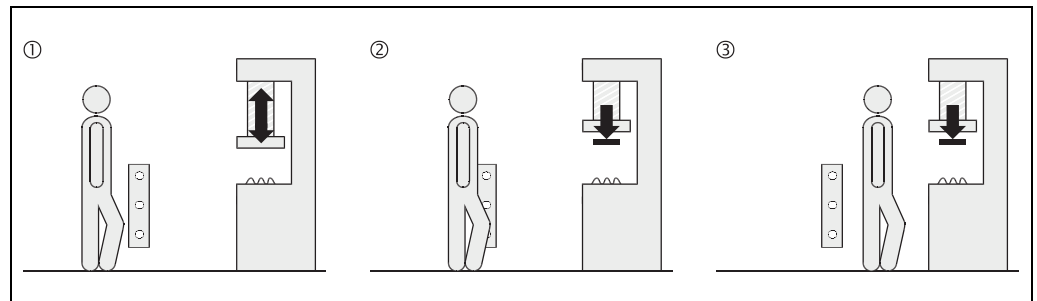

The dangerous state of the machine ① is interrupted if the light path is broken ②, and is not re-enabled ③ until the operator presses the reset button situated outside the hazardous area.

**Note** Do not confuse the restart interlock with the start interlock on the machine. The start interlock prevents the machine starting after switching on. The restart interlock prevents the machine starting again after an error or an interruption in the light path.

You can prevent the machine restarting in two ways:

- With the internal restart interlock of the M4000:  
The M4000 controls the restart.
- With the restart interlock of the machine (external):  
The M4000 has no control over the restart.

Tab. 6: Permissible configuration of the restart interlock

The possible combinations are shown in the following table:

Restart interlock of the M4000	Restart interlock of the machine	Permissible application
Deactivated	Deactivated	Only when it is not possible to stand behind the multiple light beam safety device. Observe EN 60 204-1!
Deactivated	Activated	All
Activated	Deactivated	Only when it is not possible to stand behind the multiple light beam safety device. Observe EN 60 204-1!
Activated	Activated	All. The restart interlock of the M4000 handles the <i>Reset</i> function (see “Reset” further below).



WARNING

#### Always configure the application with restart interlock!

Ensure that there is always a restart interlock. The M4000 is unable to verify if the restart interlock of the machine is operable. If you deactivate both the internal and the external restart interlock, the users and operators of the machine will be at acute risk of injury.

The electrical connection of the reset button is described in chapter 6.4 “Reset button/restart button” on page 52.

#### Recommendation

You can indicate the status “Reset required” using a signal lamp. The multiple light beam safety device has an application diagnostic output (ADO) to which the signal lamp can be connected. Details can be found in chapter 4.3 “Application diagnostic output (ADO)” on page 24.

As an option, the M4000 receiver can be supplied with an additional connection for resetting. You can then use the *Reset required* output for the signal lamp.

The electrical connection of the signal lamp is described in chapter “Connection of a *Reset required* signal lamp” on page 53.



The setting is made with the aid of the configuration buttons. You will find the instructions in chapter 8 “Configuration” on page 69ff.

#### Reset

If you want to activate the restart interlock on the M4000 (internal) and also a restart interlock on the machine (external), then each restart interlock has its own button.

When actuating the reset button (for the internal restart interlock) ...

- the M4000 activates the output signal switching devices.
- the multiple light beam safety device changes to green.

Only the external restart interlock prevents the machine from restarting. After pressing the reset button for the M4000, the operator must also press the restart button for the machine. If the reset button and the restart button are not pressed in the specified sequence, the dangerous state remains disrupted.

#### Recommendation

The reset button prevents the accidental and inadvertent operation of the external restart button. The operator must first acknowledge the safe state with the reset button.

## 4.2 Beam coding

If several multiple light beam safety devices operate in close proximity to each other, the sender beams of one system may interfere with the receiver of another system. With code 1 or 2 activated, the receiver can distinguish the beams designated for it from other beams. The following settings are available: non-coded, code 1 and code 2.



WARNING

### Use different beam codings if the systems are mounted in close proximity!

Systems mounted in close proximity to each other must be operated with different beam codings (code 1 or code 2). If this precaution is neglected, the system may be impaired in its protective function by the beams from the neighbouring system and so change to the unsafe state. This would mean that the operator is at risk.

Fig. 13: Schematic illustration of the beam coding

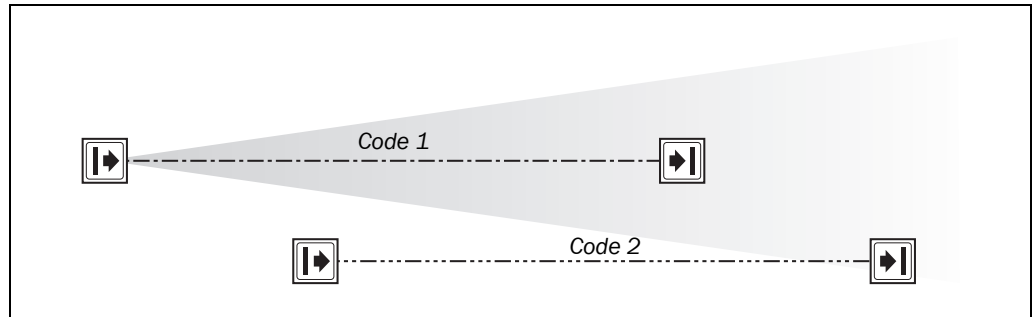

- Note**
- Beam coding increases the availability of the protected machine. Beam coding also enhances the resistance to optical interference such as weld sparks or similar.
  - Within a system the beam coding must be set for every device (sender **and** receiver).
  - After activating the system, sender and receiver will briefly display the coding.



The setting is made with the aid of the configuration buttons. You will find the instructions in chapter 8 “Configuration” on page 69ff.

### 4.3 Application diagnostic output (ADO)

The M4000 has an application diagnostic output (ADO) that can be configured. With the aid of the application diagnostic output, the multiple light beam safety device can signal specific states. You can use this output for a relay or a PLC.



WARNING

**You must not use the application diagnostic output for safety-relevant functions!**

You are only allowed to use the application diagnostic output for signalling. You must never use the application diagnostic output for controlling the application or with safety-relevant functions.

The connection can signal one of the following states:

Assignment	Possible uses
Contamination (OWS)	Eases diagnostics in case of contaminated front screen
OSSD status	Signals the status of the output signal switching devices when the multiple light beam safety device switches to red or green <sup>1)</sup>
Reset required	Signals the status "Reset required"

Tab. 7: Possible configuration for the application diagnostic output

The electrical connection of a PLC to the application diagnostic output is described in chapter 6.5 "Application diagnostic output (ADO)" on page 54.



The setting is made with the aid of the configuration buttons. You will find the instructions in chapter 8 "Configuration" on page 69ff.

### 4.4 Scanning range



WARNING

**Configure the scanning range to suit the dimension of the light path between sender and receiver!**

You must adjust the scanning range of every system to the dimension of the light path between sender and receiver.

- If the scanning range is set too low, the multiple light beam safety device may not switch to green.
- If the scanning range is set too large, the multiple light beam safety device may malfunction due to reflections. This would mean that the operator is at risk.

- Notes**
- Additional front screens (SICK accessories see page 99) reduce the effective scanning range.
  - Deflector mirrors (e.g. mirror columns, see page 100f.) reduce the effective scanning range. It is dependent on the number of deflector mirrors in the light path.
  - A further reduction in the scanning range is possible due to soiling, e.g. of the additional front screens or deflector mirrors used.
  - The scanning ranges with deflector mirrors given apply for beam deflections between 80° and 110°.

<sup>1)</sup> With external device monitoring activated, the OSSD status function cannot be configured as **active LOW**.



#### 4.4.1 Scanning range of the M4000 Standard

You can set the M4000 Standard multiple light beam safety device to two different scanning ranges. The effective scanning range is dependent here upon the dimension of the light path between sender and receiver and the number of deflector mirrors and additional front screens used. You will find the necessary scanning ranges and the resulting setting in Tab. 8.

The following scanning ranges are available:

- low scanning range (0.5-20 m)
- high scanning range (9-70 m)



The setting is made with the aid of the configuration buttons. You will find the instructions in chapter 8 "Configuration" on page 69ff.

Tab. 8: Scanning range of the M4000 Standard as a function of the number of deflections per beam and the additional front screens

Number of deflections per beam	Number of additional front screens	M4000 Standard with short scanning range	M4000 Standard with long scanning range
None	Without	0.5-20.0 m	9.0-70.0 m
	1	0.5-18.4 m	9.0-64.4 m
	2	0.5-16.9 m	9.0-59.2 m
1	Without	0.5-18.0 m	9.0-63.0 m
	1	0.5-16.5 m	9.0-57.9 m
	2	0.5-15.1 m	9.0-53.2 m
2	Without	0.5-16.0 m	9.0-56.0 m
	1	0.5-14.7 m	9.0-51.5 m
	2	0.5-13.5 m	9.0-47.3 m
3	Without	0.5-14.3 m	9.0-50.0 m
	1	0.5-13.1 m	9.0-46.0 m
	2	0.5-12.0 m	9.0-42.3 m
4	Without	0.5-12.8 m	9.0-45.0 m
	1	0.5-11.7 m	9.0-41.4 m
	2	0.5-10.7 m	9.0-38.0 m

#### 4.4.2 Scanning range of the M4000 Standard A/P

With the M4000 Standard A/P multiple light beam safety device you must differentiate between the **scanning range to be configured** and the **maximum effective scanning range**.

You must configure the scanning range to be configured to suit the deflector unit used (mirror deflection or fibre-optic deflection) (see Tab. 9).

Tab. 9: Scanning range of the M4000 Standard A/P to be configured dependent of the deflector unit used

Deflector unit used	Scanning range to be configured
Mirror deflection <ul style="list-style-type: none"> <li>• M4000 Passive with mirror deflection</li> </ul> <b>or</b> <ul style="list-style-type: none"> <li>• two deflector mirrors PSK45 (see section 11.3.9 “Deflector mirror PSK45” on page 93)</li> </ul> <b>or</b> <ul style="list-style-type: none"> <li>• one mirror column (part number: 1041917, see section 12.5 “Deflector mirrors and mirror columns” page 100)</li> </ul>	Low scanning range
Fibre-optic deflection <ul style="list-style-type: none"> <li>• M4000 Passive with fibre-optic deflection</li> </ul>	High scanning range



The setting is made with the aid of the configuration buttons. You will find the instructions in chapter 8 “Configuration” on page 69ff.

The effective scanning range is dependent here on the number of deflections between the M4000 Standard A/P and the M4000 Passive and the number of additional front screens used (see Tab. 10).

Tab. 10: Maximum effective scanning range of the M4000 Standard A/P as a function of the number of deflections and the number of additional front screens

Number of deflections <sup>2)</sup>	Number of additional front screens	Maximum scanning range	
		Mirror deflection	Fibre-optic deflection
None	Without	7.5 m	4.5 m
	1	6.3 m	3.8 m
	2	5.1 m	3.5 m
1	Without	6.0 m	Not recommended
	1	5.1 m	Not recommended
	2	4.3 m	Not recommended

<sup>2)</sup> Between M4000 Standard A/P and M4000 Passive.

**4.5 External device monitoring (EDM)**

The external device monitoring (EDM) checks if the contactors actually de-energize when the protective device responds. If you activate external device monitoring, then the M4000 checks the contactors after each interruption to the light path and prior to machine restart. The EDM can so identify if one of the contacts has fused, for instance. In this case the external device monitoring places the system in the safe operational status. The OSSDs are not re-activated in this case.

**Note** The indicators and the operational status after the external device monitoring has triggered are dependent on the type of error present and the configuration of the internal restart interlock in the M4000 (see Tab. 11).

Tab. 11: Device status after the external device monitoring has triggered

Internal restart interlock of the M4000	Signal on the EDM input	Device status after the external device monitoring has triggered		
		Display of the 7-segment display	Display of the diagnostics LED	Operational status
Activated	Permanently 0 V		● Red	Output signal switching devices off
	Permanently 24 V		● Red ● Yellow	Output signal switching devices off and "Reset required"
Deactivated	Permanently 0 V		● Red	Output signal switching devices off
	Permanently 24 V		● Red	Lock-out

The electrical connection for the external device monitoring is described in chapter 6.3 "External device monitoring (EDM)" on page 52.



The setting is made with the aid of the configuration buttons. You will find the instructions in chapter 8 "Configuration" on page 69ff.

## 4.6 Sender test

**Note** The function Sender test is not available with the M4000 Standard A/P.

The M4000 sender has a test input on pin 5 for checking the sender and the related receiver. During the test, the sender no longer emits light beams.

- During the test the sender indicates .
- The test is successful, if the M4000 receiver switches to red, i.e. the output signal switching devices (OSSDs) are deactivated.

**Note** M4000 sender and receiver are self-testing. You only need to configure the function of the sender test if this is necessary for an older existing application.

To be able to perform a sender test, ...

- the function Sender test must be configured.
- a means of controlling the test input must be available.

The electrical connection at the test input is described in chapter 6.6 “Test input (sender test)” on page 55.

The pin assignment of the system connection is described in chapter 6.1 “System connection M12 × 7 + FE” on page 50.



The setting is made with the aid of the configuration buttons. You will find the instructions in chapter 8 “Configuration” on page 69ff.

## 4.7 M4000 with integrated interface for AS-Interface Safety at Work (optional)

As an option, the M4000 multiple light beam safety device is available with an integrated interface for AS-Interface Safety at Work. With this interface you can interface the M4000 multiple light beam safety device to an AS-Interface network as an AS-Interface slave.



WARNING

**Please observe the following procedures in order to ensure the correct and safe use of the M4000 multiple light beam safety device in connection with the AS-Interface!**

- The M4000 multiple light beam safety device is only allowed to be used for connecting to AS-Interface networks.
- The M4000 multiple light beam safety device can only be connected to the machine controller via the AS-Interface network and the AS-Interface safety monitor.
- Extensive knowledge of the operation of the AS-Interface safety monitor and its configuration and diagnostics software is a prerequisite for the correct integration of the M4000 multiple light beam safety device.

### 4.7.1 The principle of the AS-Interface Safety at Work

AS-Interface Safety at Work is the standard for safe data transmission with which the protective devices are integrated into an AS-Interface network. It combines safe data and data that is not safe in mixed operation on one bus system.

The components for Safety at Work are, in compliance with EN 50 295 and IEC 62026-2, compatible with all other AS-Interface components. Existing AS-Interface applications can therefore be straightforwardly extended with safety-relevant functions.

AS-Interface Safety at Work always requires a safety monitor that evaluates the safe signals in the bus, and a safe AS-Interface bus circuit that makes it possible to transmit safe signals from safety-relevant components.

There are two types for the safe AS-Interface bus node:

- safety slaves to which safety-relevant components, e.g. ESPE, emergency stop buttons or safety door switches can be connected
- safety-relevant components with already integrated AS-Interface Safety at Work e.g. M4000

A PLC or a special master is not necessary.

There can be several safety monitors and up to 31 safety slaves in an AS-Interface system. The parameters for the safety monitors can be set and diagnostics can be performed using the AS-Interface and configuration software.

With AS-Interface Safety at Work, safety requirements up to category 4 according to EN ISO 13849-1, up to type 4 according to IEC 61496-1 and up to SIL3 according to IEC 61508 can be met.

**Note** All components connected must comply with these safety standards, thus e.g. the safety monitors, the safety slaves with the safety-relevant components connected and the safety-relevant components with AS-Interface Safety at Work already integrated.

#### 4.7.2 Principle of operation of the M4000 with integrated AS-Interface

Every M4000 has a unique 8 × 4 bit code table. With the aid of the code table, the state of the multiple light beam safety device is sent to the AS-Interface safety monitor.

A distinction should be made between the following indications:

- light path unoccupied and green LED illuminated

A unique code table is present at the integrated interface for AS-Interface Safety at Work.

- light path interrupted and red LED illuminated

A code table with the bit sequence 0000 is present for at least 500 ms (after an interruption) at the integrated interface for AS-Interface Safety at Work.

**Note** The principle of operation described in this section refers to the receiver for the M4000. The connection of the sender to the AS-Interface network is only used for the supply of power.

#### 4.7.3 Functions that can be configured on the use of the M4000 with integrated interface for AS-Interface Safety at Work

When you use the M4000 with integrated interface for AS-Interface Safety at Work, you can set the following device functions using configuration buttons:

Tab. 12: Device functions that can be configured on the use of the M4000 with integrated AS-Interface Safety at Work

On the sender	On the receiver or M4000 Standard A/P
<ul style="list-style-type: none"> <li>• beam coding</li> </ul>	<ul style="list-style-type: none"> <li>• beam coding</li> <li>• scanning range</li> </ul>

#### Restart interlock

**Note** The M4000 multiple light beam safety device with integrated AS-Interface Safety at Work does **not** have an internal restart interlock.

If your application requires a restart interlock, then you must realise a restart interlock externally using the AS-Interface safety monitor. You will find more information in the operating instructions for the AS-Interface safety monitor.

#### 4.7.4 Replacing a M4000 with integrated AS-Interface

If a M4000 multiple light beam safety device is faulty and must be replaced as a safe AS-Interface- slave, this can be achieved without a PC and without re-configuring the AS-Interface safety monitor with the aid of the **Service** button on the AS-Interface safety monitor.

- Notes**
- You will find detailed instructions in the operating instructions for the AS-Interface safety monitor.
  - Functions configured in the M4000 multiple light beam safety device must be set again on each device after a replacement.

## 5 Mounting

This chapter describes the preparation and completion of the installation of the M4000 multiple light beam safety device. The mounting requires two steps:

- calculation of the necessary minimum distance
- mounting with swivel mount or side bracket, rigid or pivoting mounting bracket

The following steps are necessary after mounting and installation:

- completing the electrical connections (chapter 6)
- aligning sender and receiver (chapter 7.3)
- testing the installation (chapter 7.4)

### 5.1 Calculation of the minimum distance

The M4000 multiple light beam safety device must be mounted with an adequate minimum distance:

- to the hazardous area
- from reflective surfaces



WARNING

---

#### No protective function without sufficient minimum distance!

- You must mount the multiple light beam safety devices with the correct minimum distance to the hazardous area. Otherwise the safe protection of the M4000 system is not provided.

#### Risk of failure to detect!

- Persons who are in the hazardous area but not in the light path between sender and receiver are not detected by the M4000 system. It is therefore to be ensured that the hazardous area is fully visible and any dangerous state can only be initiated if there are no personnel in the hazardous area.
- The M4000 system is not allowed to be used for hand and finger protection.

#### Read and follow the relevant safety standards!

The procedure described in the following sections for the calculation of the minimum distance is no substitute for knowledge of the related safety standards.

➤ Therefore read and follow in particular the standards stated in the following sections.

You will find further information on the application of the standards during the calculation of the minimum distance in the SICK reference brochure “Guidelines Safe Machinery” (Part No. 8007988).

---

**Note** The applicable legal and official regulations apply to the use and mounting of the protective device. These regulations vary depending on the application.

### 5.1.1 Minimum distance to the hazardous area

A minimum distance must be maintained between the multiple light beam safety device and the hazardous area. This ensures that the hazardous area can only be reached when the dangerous state of the machine is completely at an end.

**The minimum distance as defined in EN ISO 13 855 and EN ISO 13 857 depends on:**

- stopping/run-down time of the machine or system  
(The stopping/run-down time is shown in the machine documentation or must be determined by taking a measurement.)
- response time of the protective device (response times see chapter 11.1 “Data sheet” on page 79)
- reach or approach speed
- resolution of the multiple light beam safety device or beam separation
- other parameters that are stipulated by the standard depending on the application

**Under the authority of OSHA and ANSI the minimum distance as specified by ANSI B11.19:2003-04, Annex D and Code of Federal Regulations, Volume 29, Part 1910.217 ... (h) (9) (v) depends on:**

- stopping/run-down time of the machine or system  
(The stopping/run-down time is shown in the machine documentation or must be determined by taking a measurement.)
- response time of the protective device (response times see chapter 11.1 “Data sheet” on page 79)
- reach or approach speed
- other parameters that are stipulated by the standard depending on the application

#### Calculation of the minimum distance for perpendicular approach

Fig. 14: Minimum distance to the hazardous point for perpendicular approach

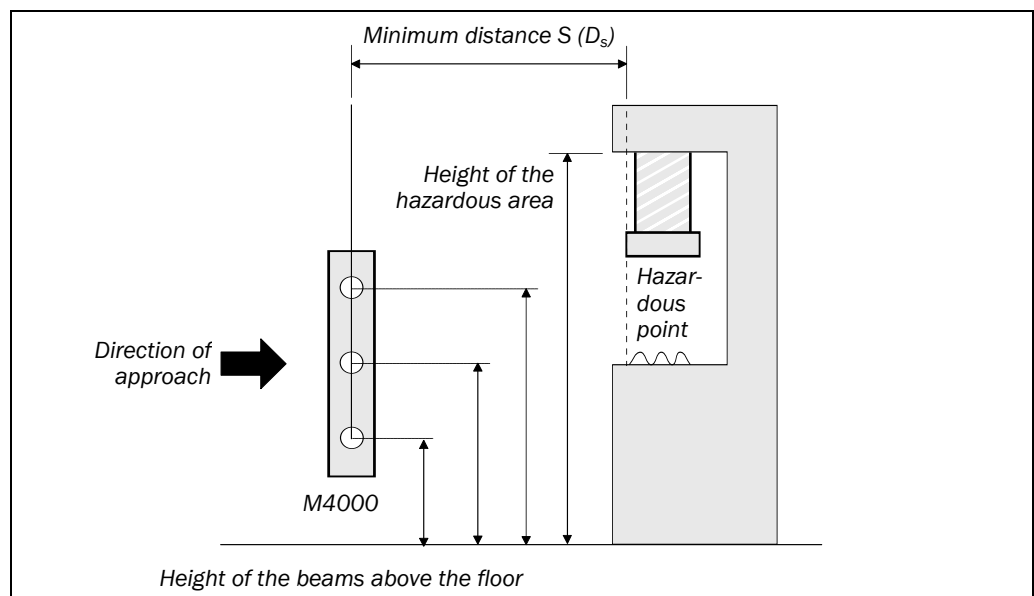



### How to calculate the minimum distance S according to EN ISO 13 855 and EN ISO 13 857:

**Note** The following calculation shows an example calculation of the minimum distance. Depending on the application and the ambient conditions, a different calculation may be necessary.

➤ First, calculate S using the following formula:

$$S = 1600 \times T + C \text{ [mm]}$$

Where ...

T = Stopping/run-down time of the machine  
+ Response time of the M4000 system after light path interruption [s]

S = Minimum distance [mm]

C = Supplement [mm], depending on the number of beams (1, 2, 3 or 4)  
If it is possible to reach over the vertical protective field of an ESPE, the supplement C must be determined as per the tables in EN ISO 13 855. Here the following always applies:  $C_{RO}$  (reaching over)  $\geq C_{RT}$  (reaching through)

#### Example 1: Access protection with two beams for a hazardous point, where there is no risk of reaching over:

$$C = 850 \text{ mm}$$

Stopping/run-down time of the machine = 290 ms

Response time of the light path interruption = 30 ms

$$T = 290 \text{ ms} + 30 \text{ ms} = 320 \text{ ms} = 0.32 \text{ s}$$

$$S = 1600 \times 0.32 + 850 = 1362 \text{ mm}$$

#### Example 2: Access protection with three beams for a hazardous point, where there is a risk of reaching over:

- three-beam standard ESPE (300/400/1100 mm)

- height of the top edge of the protective field: 1100 mm

- height of the hazardous area: 1400 mm

As per EN ISO 13 855 a resolution-dependent supplement C of 1100 mm applies (instead of the previously usual 850 mm).

$$C = 1100 \text{ mm}$$

Stopping/run-down time of the machine = 290 ms

Response time of the light path interruption = 30 ms

$$T = 290 \text{ ms} + 30 \text{ ms} = 320 \text{ ms} = 0,32 \text{ s}$$

$$S = 1600 \times 0,32 + 1100 = 1612 \text{ mm}$$

### How to calculate the minimum distance $D_s$ according to ANSI B11.19:2003-04, Annex D and Code of Federal Regulations, Volume 29, Part 1910.217 ... (h) (9) (v):

**Note** The following calculation shows an example calculation of the minimum distance. Depending on the application and the ambient conditions, a different calculation may be necessary.

➤ First, calculate  $D_s$  using the following formula:

$$D_s = H_s \times (T_s + T_c + T_r + T_{bm}) + D_{pf}$$

Where ...

$D_s$  = The minimum distance in inches (or millimetres) from the hazardous point to the protective device

$H_s$  = A parameter in inches/second or millimetres/second, derived from data on approach speeds of the body or parts of the body.  
Often 63 inches/second is used for  $H_s$ .

$T_s$  = Stopping/run down time of the machine tool measured at the final control element

$T_c$  = Stopping/run-down time of the control system

$T_r$  = Response time of the entire protective device after light path interruption

$T_{bm}$  = Additional response time allowed for brake monitor to compensate for wear

**Note**

Any additional response times must be accounted for in this calculation.

$D_{pf}$  = An additional distance added to the overall minimum distance. This value is based on a possible intrusion toward the hazardous point prior to actuation of the electro-sensitive protective equipment (ESPE). For applications that can be reached over, the value  $D_{pf} = 1.2$  m. For beam arrangements that permit reaching in with the arms or the detectable object size is greater than 63 mm, the value  $D_{pf} = 0.9$  m.

The applicable legal and official regulations apply to the use and mounting of the protective device. These regulations vary depending on the application.

**Calculation of the minimum distance S for non-perpendicular approach**

Fig. 15: Minimum distance to the hazardous point for non-perpendicular approach

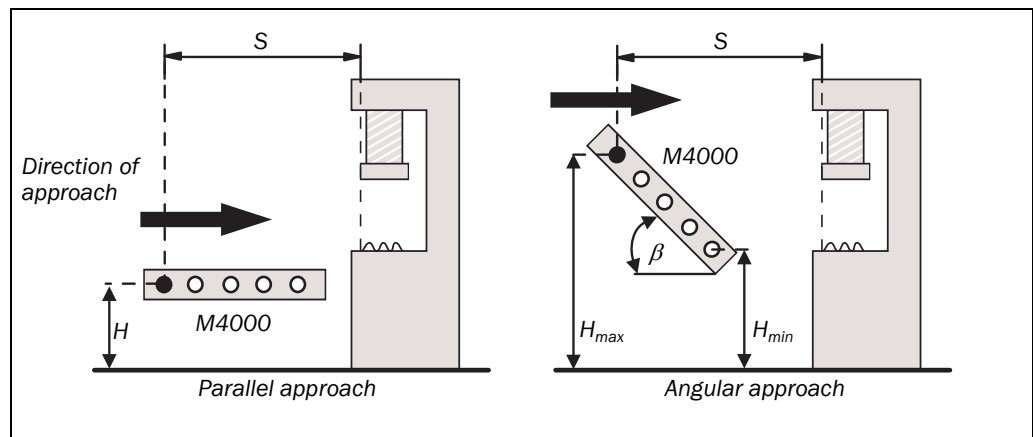

Tab. 13: Equations for calculating the minimum distance S

Approach	Calculation	Conditions
Parallel	$S = 1600 \times T + (1200 - 0.4 \times H)$ [mm]	<ul style="list-style-type: none"> <li><math>1200 - 0.4 \times H &gt; 850</math> mm</li> <li><math>15 \times (d - 50) \leq H \leq 1000</math> mm</li> </ul>
Angular	<ul style="list-style-type: none"> <li><math>\beta &gt; 30^\circ</math> Calculation as for perpendicular approach</li> <li><math>\beta &lt; 30^\circ</math> Calculation as for parallel approach</li> </ul> <p>S is applied to the beam that is the farthest away from the hazardous point.</p>	<ul style="list-style-type: none"> <li><math>d \leq H_{min}/15 + 50</math></li> <li><math>H_{max} \leq 1000</math> mm</li> </ul>

Where ...

$S$  = Minimum distance [mm]

$H$  = Height of the beams above the floor [mm]

For approach at an angle:

$H_{\max}$  = Height of the uppermost beam [mm]

$H_{\min}$  = Height of the bottom beam [mm]

$d$  = Resolution of the multiple light beam safety device [mm]

$\beta$  = Angle between detection plane and the direction of entry

$T$  = Time

### 5.1.2 Minimum distance to reflective surfaces



WARNING

#### Maintain the minimum distance from reflective surfaces!

The light beams from the sender may be deflected by reflective surfaces. This can result in failure to identify an object. This would mean that the operator is at risk.

All reflective surfaces and objects (e.g. material bins) must be a minimum distance  $a$  from the light path between sender and receiver. The minimum distance  $a$  depends on the distance  $D$  between sender and receiver.

Fig. 16: Minimum distance to reflective surfaces

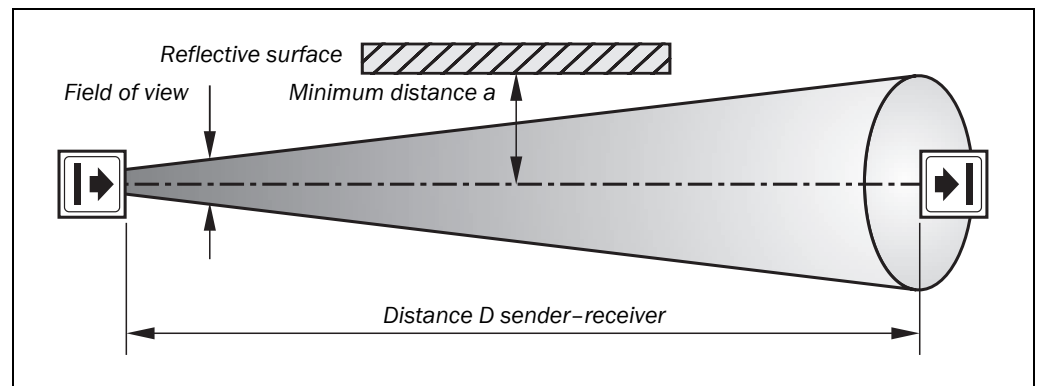

**Note** The field of view of the sender and receiver optics is identical.

**How to determine the minimum distance from reflective surfaces:**

- Determine the distance  $D$  [m] sender-receiver.
- Read the minimum distance  $a$  [mm] in the diagram or calculate it using the related formula in Tab. 14.

Fig. 17: Graph, minimum distance from reflective surfaces

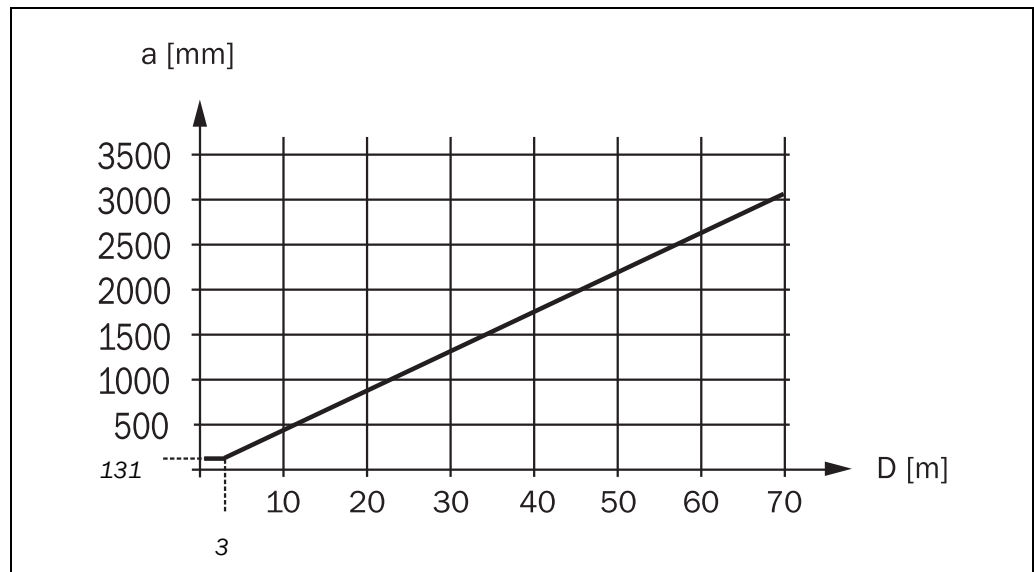

Tab. 14: Formula for the calculation of the minimum distance to reflective surfaces

Distance $D$ [m] sender-receiver	Calculation of the minimum distance $a$ from reflective surfaces
$D \leq 3$ m	$a$ [mm] = 131
$D > 3$ m	$a$ [mm] = $\tan(2.5^\circ) \times 1000 \times D$ [m] = $43.66 \times D$ [m]

**5.1.3 Minimum distance for the M4000 with integrated AS-Interface**

When calculating the minimum distance for a M4000 with integrated AS-Interface using the formula as per EN ISO 13855 and EN ISO 13857 (see section 5.1.1), the response time for the AS-Interface safety monitor is also taken into account.

**How to calculate the minimum distance S:**

$$S = 1600 \times T + C \text{ [mm]}$$

Where ...

T = Stopping/run-down time of the machine

+ Response time of the M4000 system after light path interruption

+ Response time of the AS-Interface safety monitor [s]

S = Minimum distance [mm]

C = Supplement [mm], depending on the number of beams (1, 2, 3 or 4)

If it is possible to reach over the vertical protective field of an ESPE, the supplement C must be determined as per the tables in EN ISO 13855. Here the following always applies:  $C_{RO}$  (reaching over)  $\geq$   $C_{RT}$  (reaching through)

**Example access protection with two beams:**

$$C = 850 \text{ mm}$$

Stopping/run-down time of the machine = 290 ms

Response time of the light path interruption = 30 ms

Response time of the AS-Interface safety monitor = 40 ms (maximum response time in an AS-Interface bus system with 31 slaves)

$$T = 290 \text{ ms} + 30 \text{ ms} + 40 \text{ ms} = 360 \text{ ms} = 0.36 \text{ s}$$

$$S = 1600 \times 0.36 + 850 = 1426 \text{ mm}$$

## 5.2 Steps for mounting the device



WARNING

### Special features to note during mounting:

- Always mount the sender and receiver parallel to one another.
- During mounting, ensure that sender and receiver are aligned correctly. The optical lens systems of sender and receiver must be located in exact opposition to each other; the status indicators must be mounted at the same height. The system plugs of both devices must point in the same direction.

Fig. 18: Sender and receiver must not be rotated 180° with respect to each other

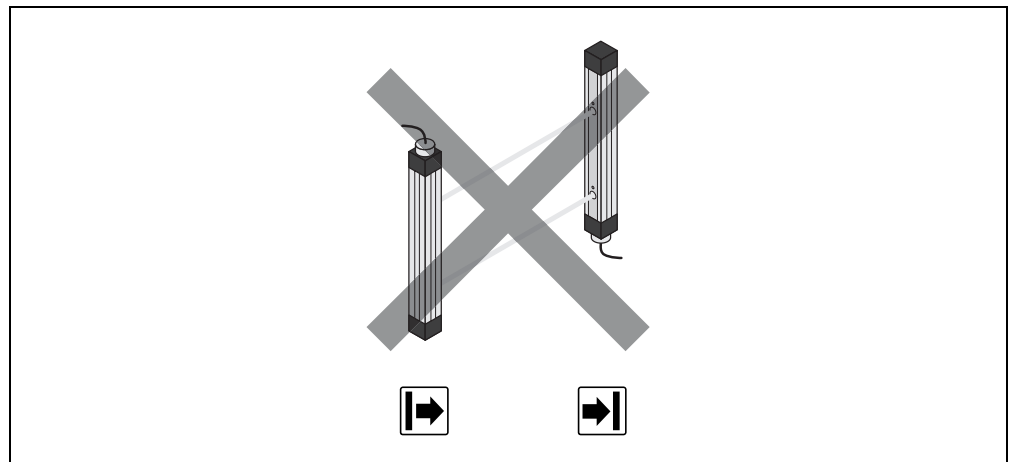

- Observe the minimum distance of the system during mounting. On this subject read the chapter 5.1 “Calculation of the minimum distance” on page 31.
- Mount the multiple light beam safety device such that the risk of failure to detect is excluded. Ensure that the protective device cannot be bypassed by crawling underneath, reaching over, climbing between 2 beams, jumping over or moving the multiple light beam safety device.

Fig. 19: The correct installation (above) must eliminate the errors (below) of reaching through and crawling beneath

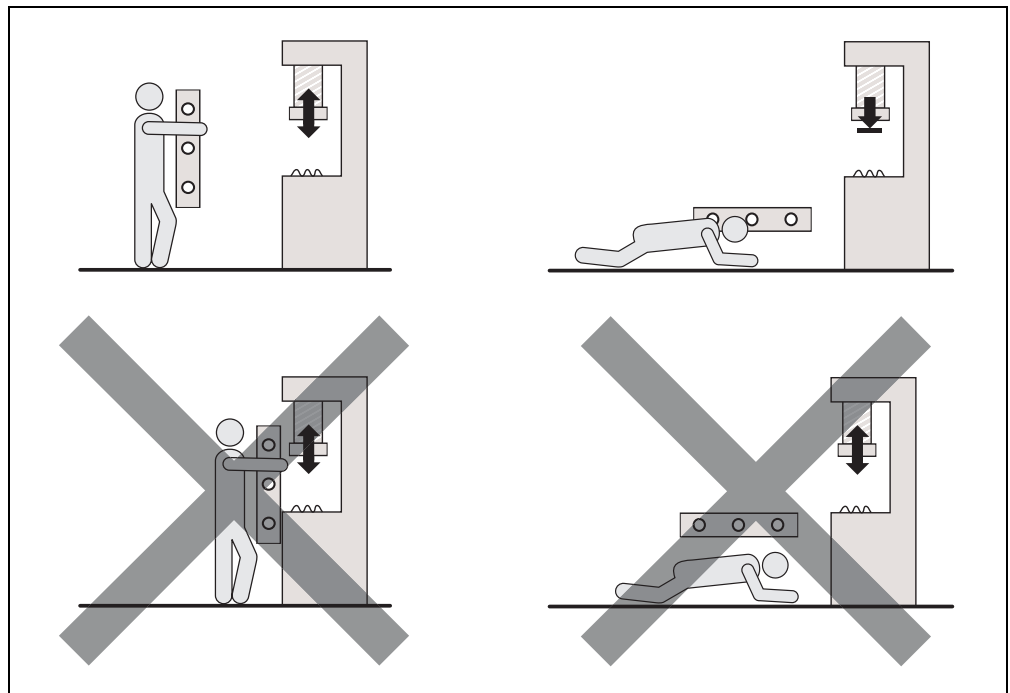

- Once the system is mounted, one or several of the enclosed self-adhesive information labels must be affixed:
  - Use only information labels in the language which the users and operators of the machine understand.
  - Affix the information labels such that they are easily visible by the users and operators during operation. After attaching additional objects and equipment, the information labels must not be concealed from view.
  - Affix the information label “Important Notices” to the system in close proximity to sender and receiver.
- When mounting a M4000 with integrated laser alignment aid, ensure that the laser warning labels on the device remain visible. If the laser warning labels are covered, e.g. on installation of the M4000 in a device column (accessory), you must apply the laser warning labels supplied with the receiver in the appropriate place on the cover.

Sender and receiver can be mounted in five different ways:

- Mounting with Omega bracket
- Mounting with swivel mount bracket
- Mounting with side bracket
- Mounting with rigid mounting bracket
- Mounting with pivoting mounting bracket

### 5.2.1 Mounting with Omega bracket

Fig. 20: Omega bracket (mm)

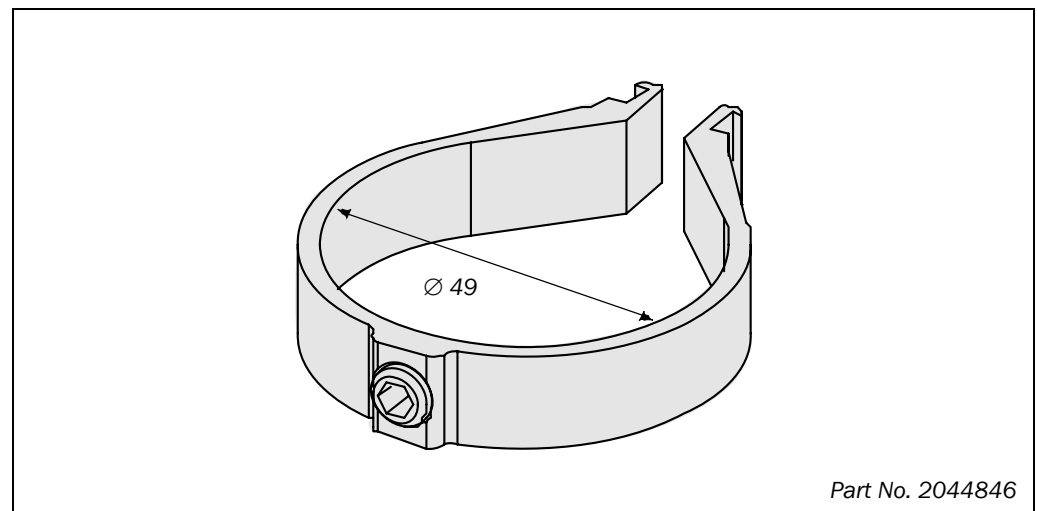

The Omega bracket is made of aluminium. The bracket is designed such that sender and receiver can also be exactly aligned after the installation and mounting of the bracket.

**Note** Attach the screws of the Omega bracket with a torque of between 2 and 2.5 Nm. Higher torques can damage the bracket; lower torques provide inadequate protection against vibration.

Fig. 21: Mounting with Omega bracket

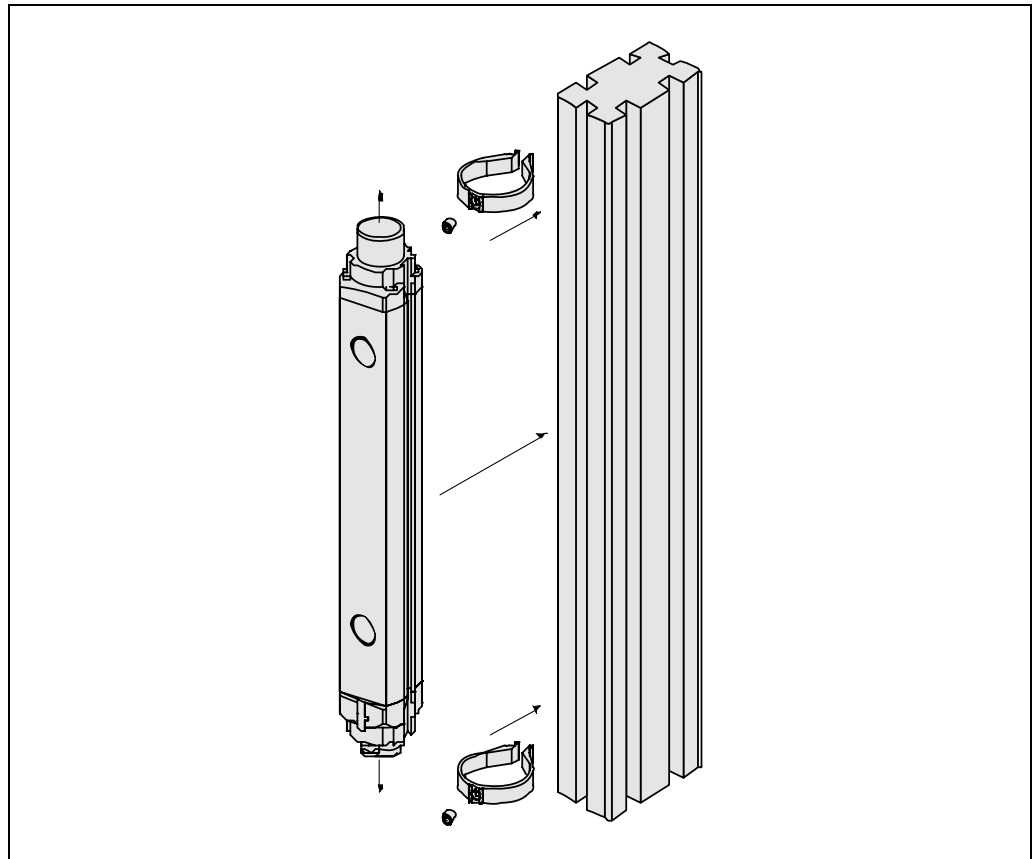

- Note** ➤ Engage the Omega fixing bracket in its profile rails. Additional spacers are used to correctly adjust the bracket in the slot. The safety light curtain can be mounted and also subsequently adjusted using just one screw.

### 5.2.2 Mounting with swivel mount bracket

The swivel mount bracket is made of high-strength black plastic. The bracket is designed such that sender and receiver can still be accurately aligned even after the bracket has been mounted.

- Note** Attach the screws of the swivel mount bracket with a torque of between 2.5 and 3 Nm. Higher torques can damage the bracket; lower torques provide inadequate protection against vibration.

Fig. 22: Composition of the swivel mount bracket

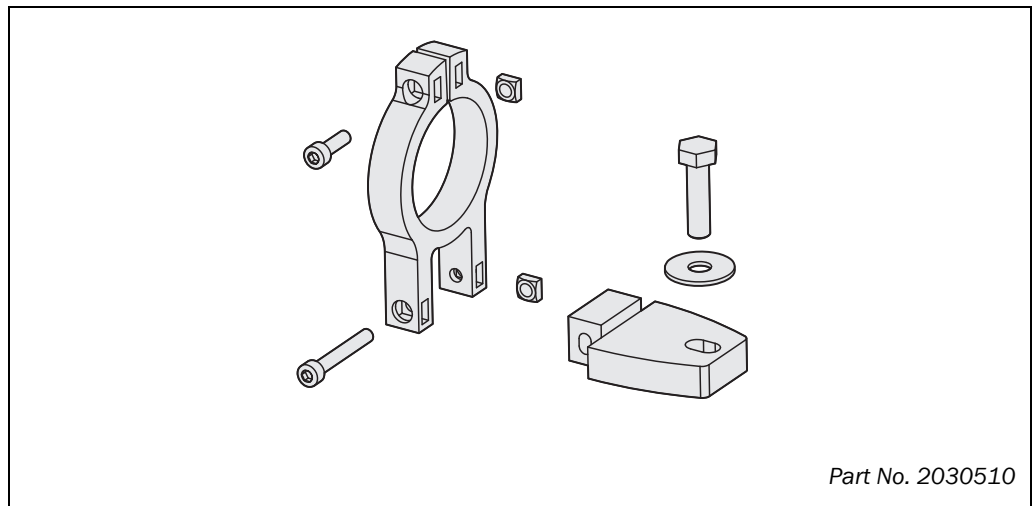

Part No. 2030510



**M4000 Std., Std. A/P**

Fig. 23: Mounting the M4000 with swivel mount bracket

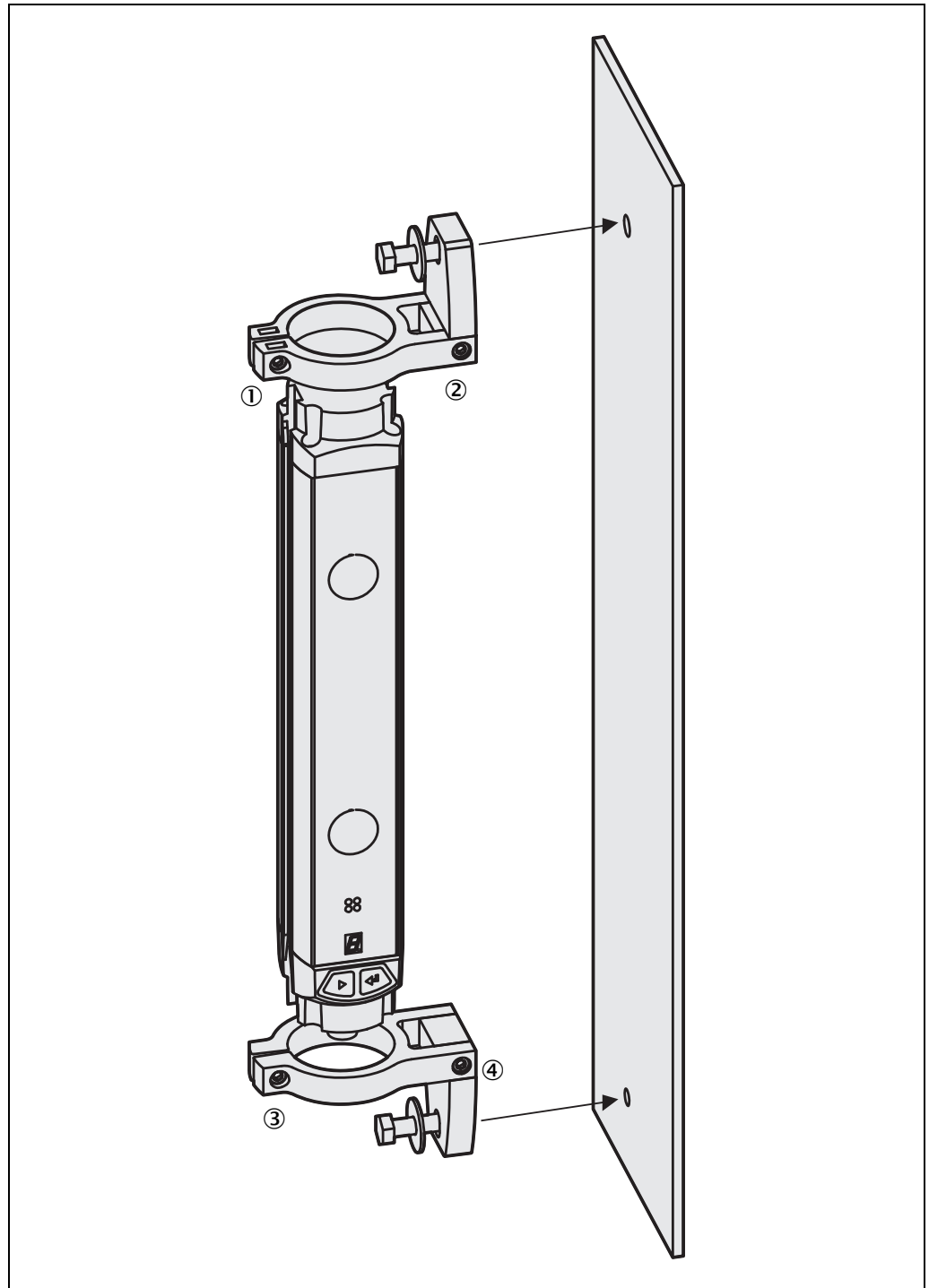

- Notes**
- Mount the bolts marked with ① to ④ on the operator side of the system to ensure that they remain accessible after mounting. The multiple light beam safety device can then also be adjusted later.
  - The mounting screw is not included in the delivery.

### 5.2.3 Mounting with side bracket

The side bracket is made of die cast zinc ZP 0400. It is enamelled in black. The side bracket will be covered by the device after mounting. It provides adjustment so that the vertical alignment of sender and receiver can be corrected by  $\pm 2.5^\circ$  after mounting.

Fig. 24: Composition of the side bracket

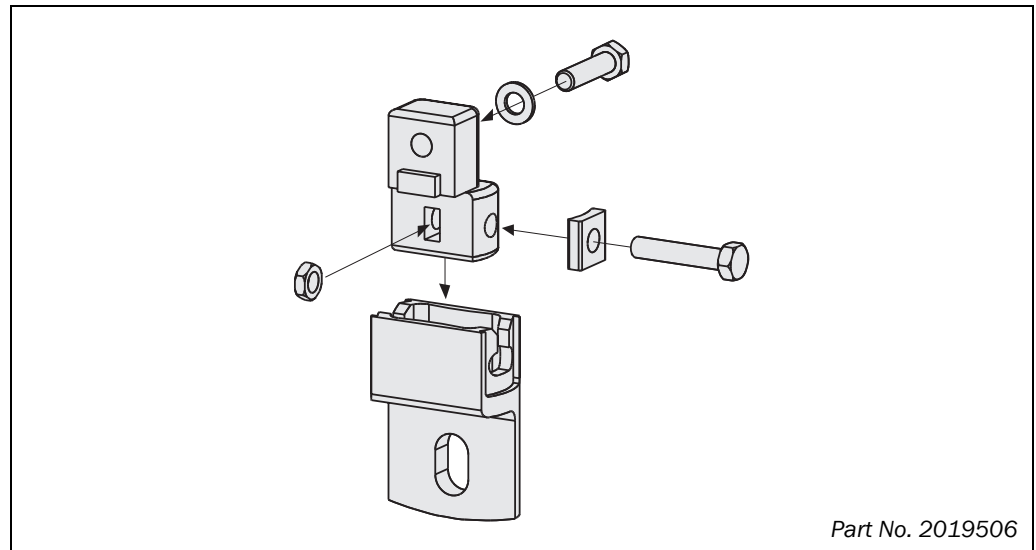

- Note** ➤ Attach the bolts of the side bracket with a torque of between 5 and 6 Nm. Higher torques can damage the bracket; lower torques provide inadequate protection against vibration.

**M4000 Std., Std. A/P**

Fig. 25: Mounting the M4000 with side bracket

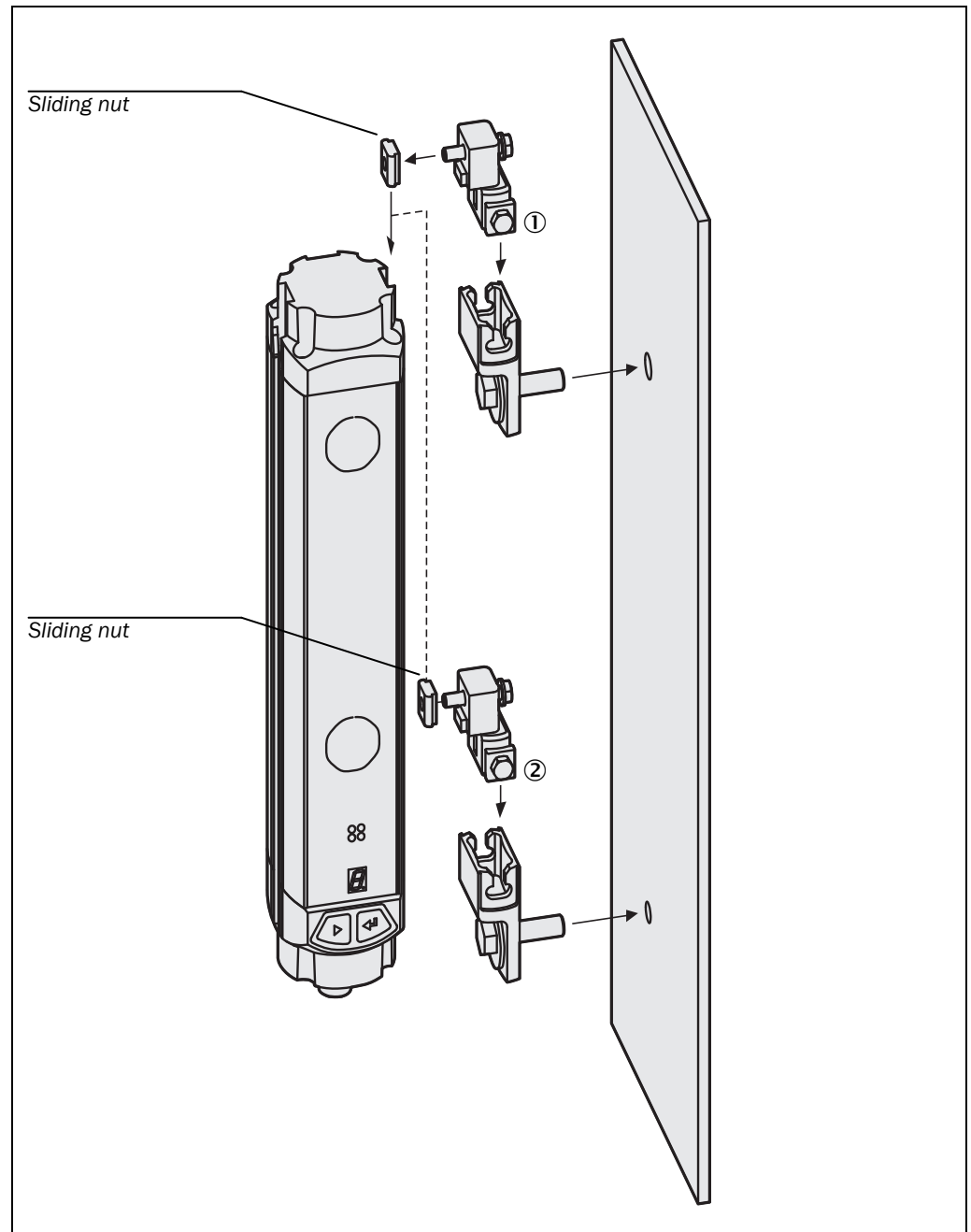

- Notes**
- When mounting the side bracket ensure that the bolts marked ① and ② remain accessible, allowing you later to adjust and lock the multiple light beam safety device in position.
  - When mounting the bracket, note the distance and the position of the sliding nuts as described in chapter 11.3 “Dimensional drawings” on page 86f.
  - The mounting screw is not included in the delivery.

**5.2.4 Mounting with rigid mounting bracket**

The rigid mounting bracket is a black, powder-coated bracket without adjustment. It is only suitable for mounting surfaces on which it is not necessary to compensate for large mechanical tolerances. The alignment of the sender and receiver can be corrected after mounting using only the slots.

Fig. 26: Rigid mounting bracket

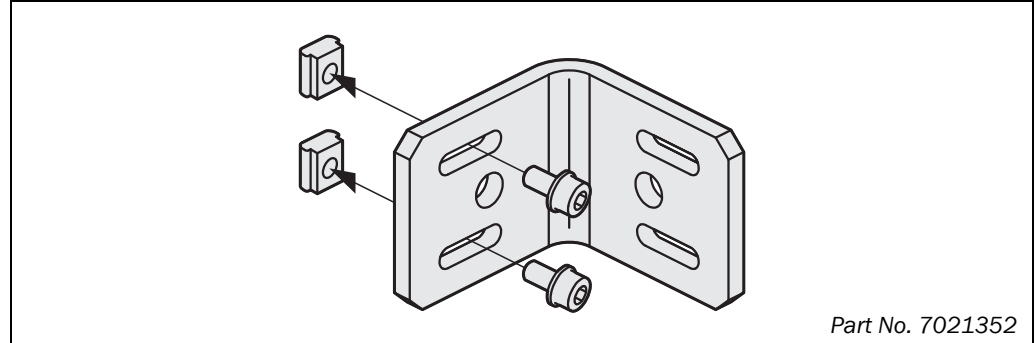

**M4000 Std., Std. A/P**

Fig. 27: Mounting the M4000 with rigid mounting bracket

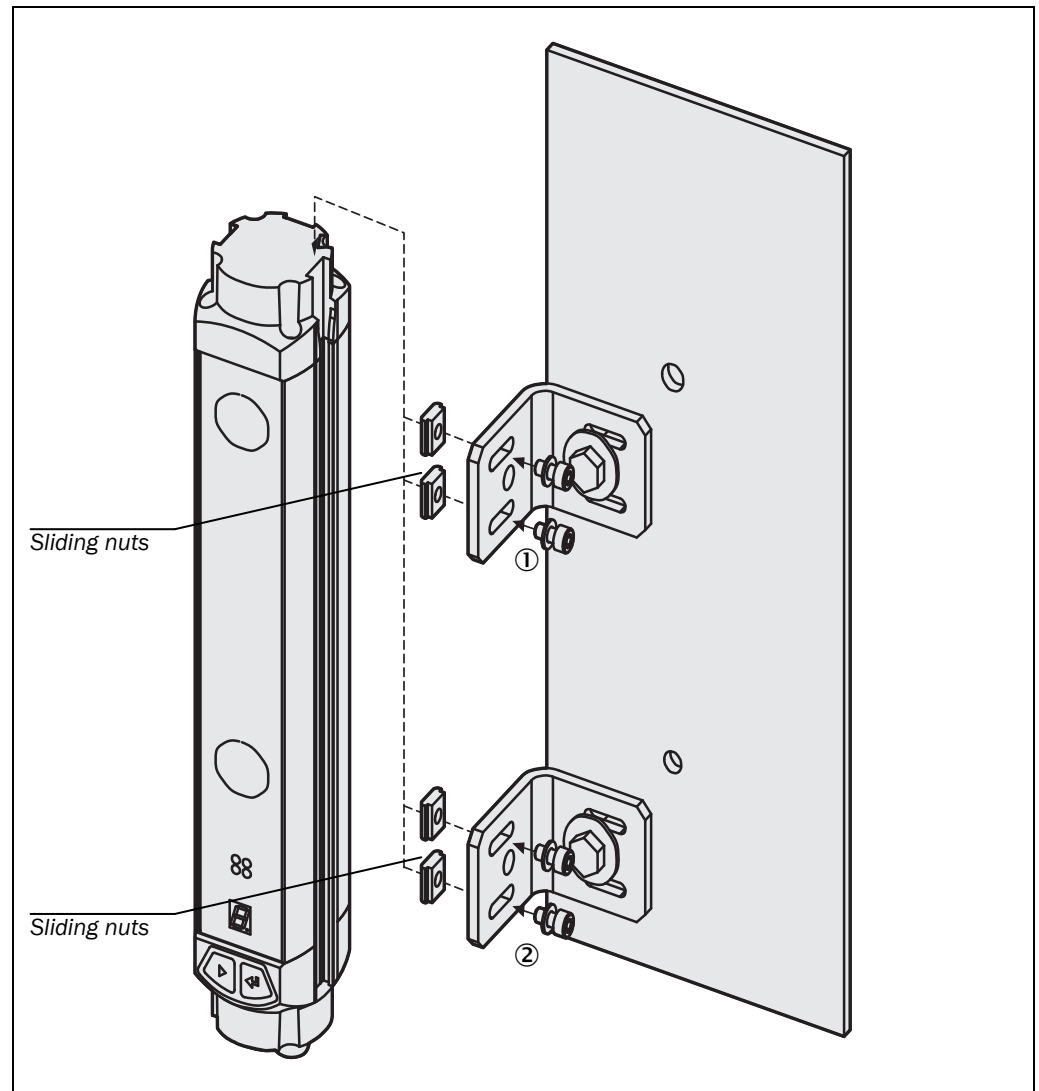

- Notes**
- When mounting the rigid mounting bracket ensure that the four bolts marked ① and ② remain accessible, allowing you later to adjust and lock the multiple light beam safety device in position.
  - When mounting the bracket, note the distance and the position of the sliding nuts as described in chapter 11.3 “Dimensional drawings” on page 86f.
  - The mounting screw is not included in the delivery.

**5.2.5 Mounting with pivoting mounting bracket**

The pivoting mounting bracket is made of black anodised aluminium. It will be covered by the device after mounting. The pivoting mounting bracket provides adjustment for correcting the horizontal alignment of sender and receiver by  $\pm 2.0^\circ$  after mounting.

Fig. 28: Assembly of the pivoting mounting bracket

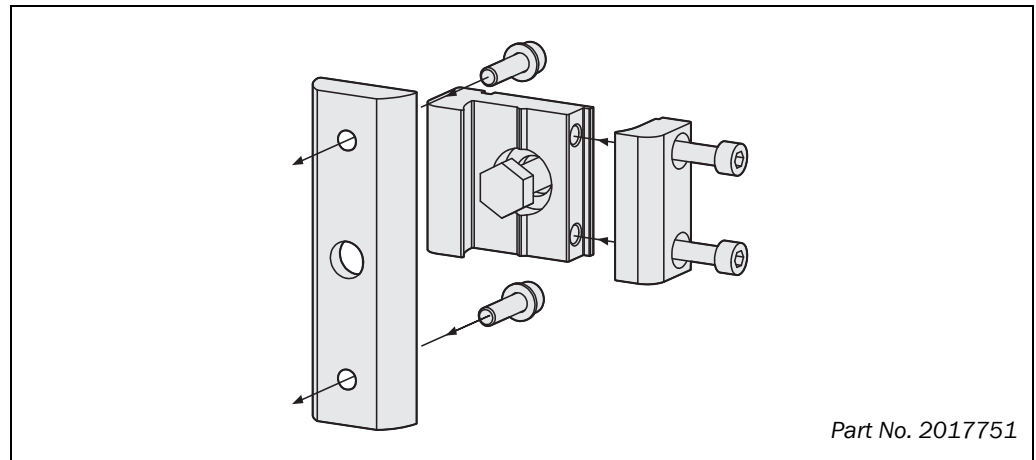

- Note** ➤ Tighten the bolts on the pivoting mounting bracket to a torque of between 5 and 6 Nm. Higher torques can damage the bracket; lower torques provide inadequate protection against vibration.

**M4000 Std., Std. A/P**

Fig. 29: Mounting the M4000 with pivoting mounting bracket

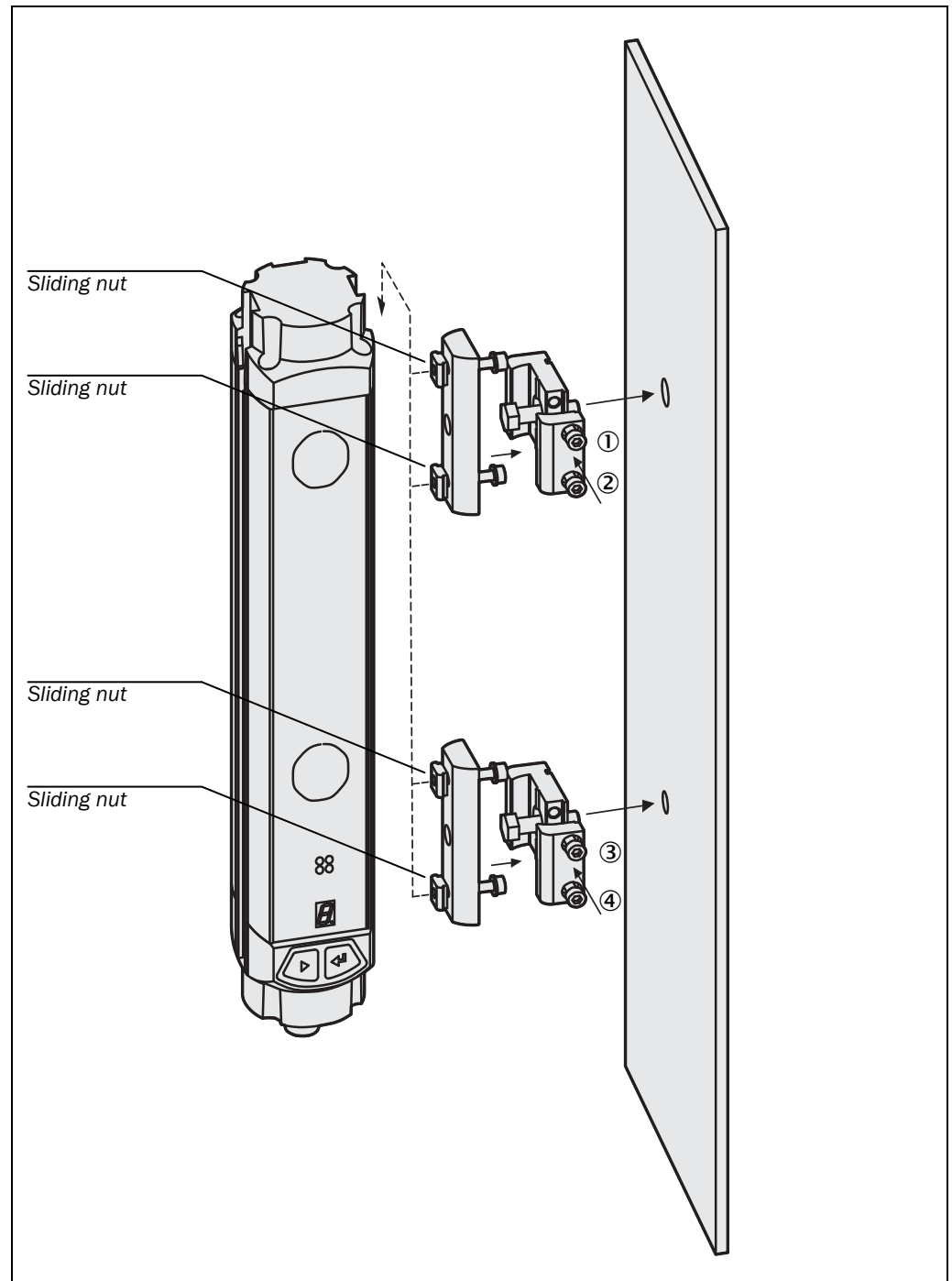

- Notes**
- When mounting the pivoting mounting bracket ensure that the bolts marked ①, ②, ③ and ④ remain accessible, allowing you later to adjust and lock the multiple light beam safety device in position.
  - When mounting the bracket, note the distance and the position of the sliding nuts as described in chapter 11.3 “Dimensional drawings” on page 86f.
  - The mounting screw is not included in the delivery.

## 6 Electrical installation



WARNING

### Switch the power supply off!

The machine/system could inadvertently start up while you are connecting the devices.

- Ensure that the entire machine/system is disconnected during the electrical installation.

### Connect OSSD1 and OSSD2 separately!

You are not allowed to connect OSSD1 and OSSD2 together, otherwise signal safety will not be ensured.

- Connect OSSD1 and OSSD2 separately to the machine controller.
- Ensure that the machine controller processes the two signals separately.

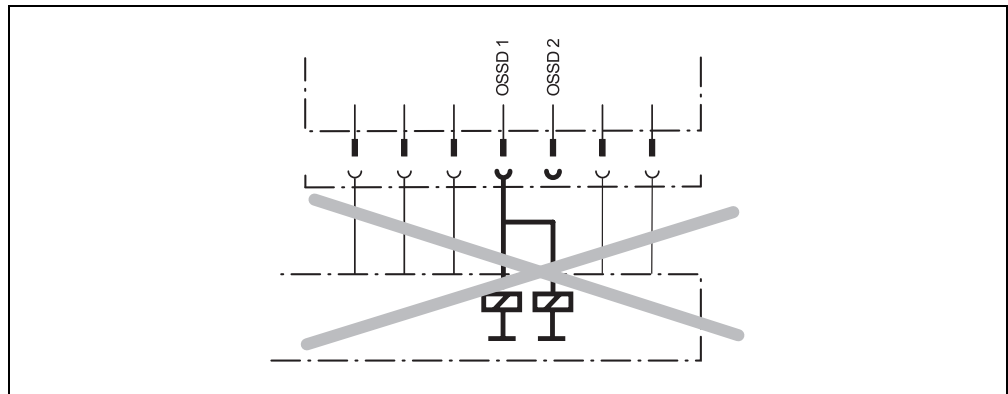

### Prevent the formation of a potential difference between the load and the protective device!

- If you connect loads that are not reverse-polarity protected to the OSSDs or the safety outputs, you must connect the 0 V connections of these loads and those of the corresponding protective device individually and directly to the same 0 V terminal strip. This is the only way to ensure that, in the event of a defect, there can be no potential difference between the 0 V connections of the loads and those of the corresponding protective device.

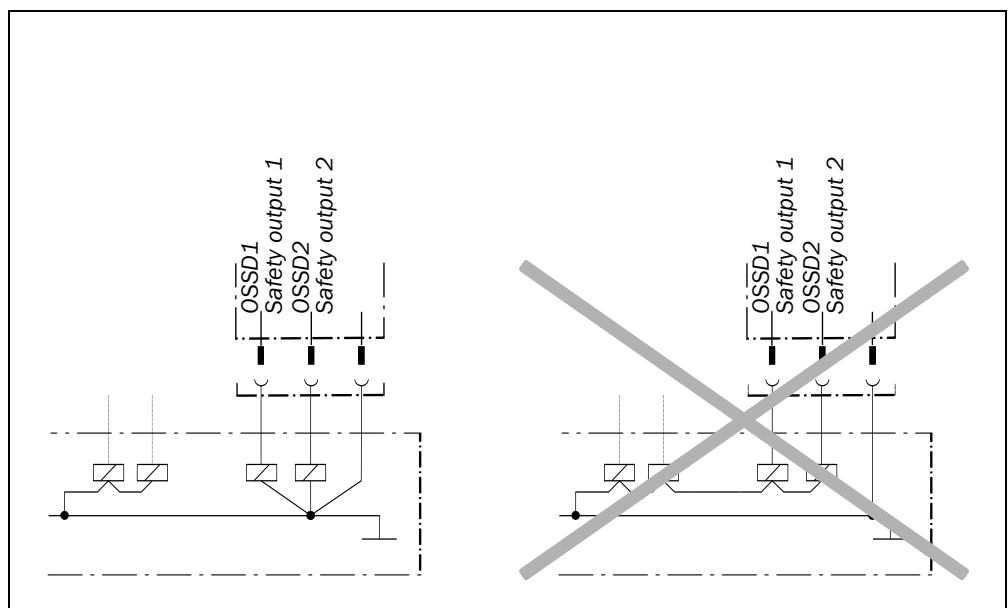



**M4000 Std., Std. A/P**

- Notes**
- The two outputs are protected against short-circuits to 24 V DC and 0 V. When the light path is clear, the signal level on the outputs is HIGH DC (at potential), when the light beams are interrupted or there is a device fault the outputs are LOW DC.
  - The M4000 multiple light beam safety device meets the interference suppression requirements (EMC) for industrial use (interference suppression class A). When used in residential areas it can cause interference.
  - To ensure full electromagnetic compatibility (EMC), functional earth (FE) must be connected. (Exception: The M4000 with integrated AS-Interface Safety at Work does not have a functional earth!)
  - The external voltage supply of the devices must be capable of buffering brief mains voltage failures of 20 ms as specified in EN 60204-1. Suitable power supplies are available as accessories from SICK (Siemens type series 6 EP 1). On devices with integrated interface for AS-Interface Safety at Work, the supply voltage must be provided as per the AS-Interface specification.
  - The plug alignment (direction of turn) in the housing may vary from device to device. You can identify the correct pin assignment by the position of the pins in relation to each other as shown in the drawings. On devices with integrated interface for AS-Interface Safety at Work the plug alignment is fixed and as shown in the related figure.

**Connections of the M4000**

The M4000 Standard or M4000 Standard A/P devices provide the following connections:

- System connection M12 × 7 + FE (see page 50)
- *AS-Interface* connection M12 × 4 (optional, see page 51)
- Connection *Reset* M12 × 5 (optional, see page 51)

## 6.1 System connection M12 × 7 + FE

### M4000 Standard or M4000 Standard A/P

Fig. 30: Pin assignment system connection M4000 Standard or M4000 Standard A/P M12 × 7 + FE

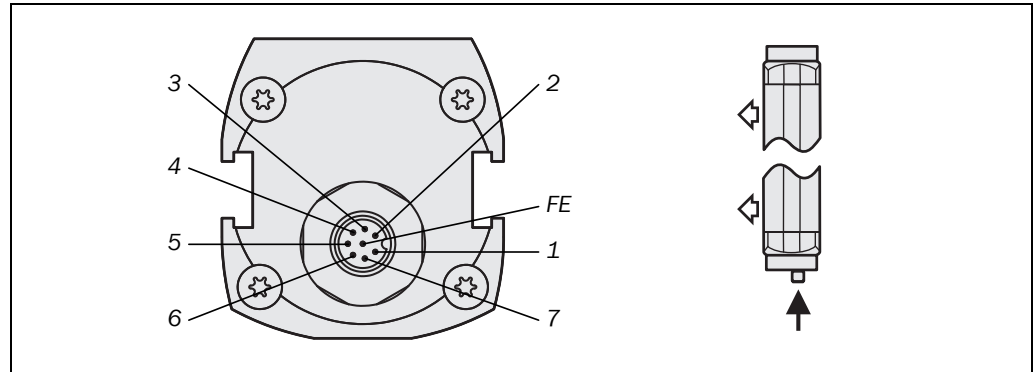

Tab. 15: Pin assignment system connection M4000 Standard or M4000 Standard A/P M12 × 7 + FE

Pin	Wire colour	☑ Sender	☑ Receiver or ☑☑ M4000 Standard A/P
1	White	Reserved	Reset/restart interlock
2	Brown	Input 24 V DC (voltage supply)	Input 24 V DC (voltage supply)
3	Green	Reserved	Application diagnostic output (ADO)
4	Yellow	Reserved	External device monitoring (EDM)
5	Grey	Test input: 0 V: external test active 24 V: external test inactive	OSSD1 (output signal switching device 1)
6	Pink	Reserved	OSSD2 (output signal switching device 2)
7	Blue	0 V DC (voltage supply)	0 V DC (voltage supply)
FE	Screen	Functional earth	Functional earth

## 6.2 Optional connections

### 6.2.1 AS-Interface connection M12 × 4

Fig. 31: Pin assignment for connection "AS-Interface" M12 × 4

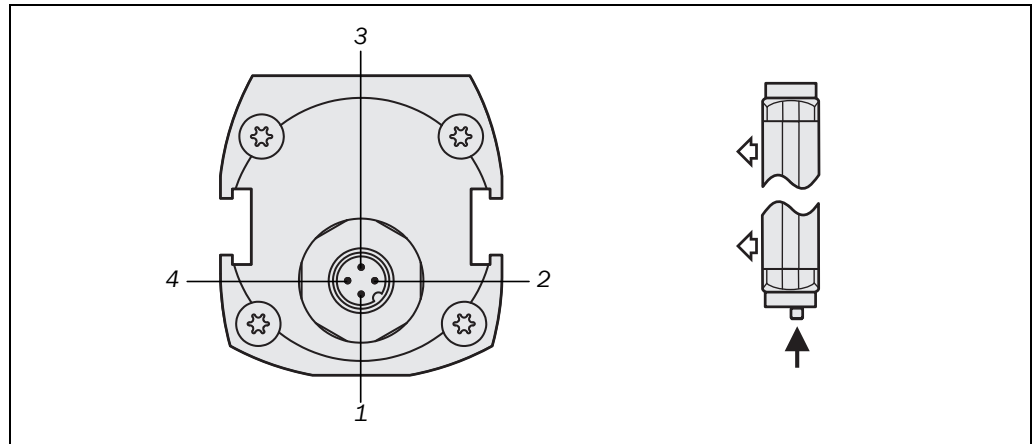

Tab. 16: Pin assignment for connection "AS-Interface" M12 × 4

Pin	☒ Sender	☒ Receiver or ☒☒ M4000 Standard A/P
1	AS-Interface+	AS-Interface+
2	Reserved, do not use!	Reserved, do not use!
3	AS-Interface-	AS-Interface-
4	Reserved, do not use!	Reserved, do not use!

- Notes**
- The connection AS-Interface M12 × 4 is available instead of the system connection.
  - An additional Reset connection is not possible.

### 6.2.2 Connection Reset M12 × 5

Fig. 32: Pin assignment for connection "Reset" M12 × 5

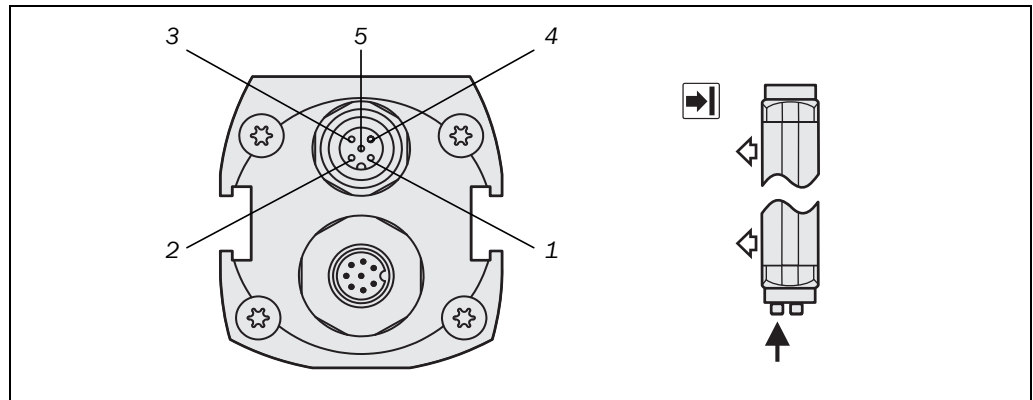

Tab. 17: Pin assignment for connection "Reset" M12 × 5

Pin	Wire colour	☒ receiver or ☒☒ M4000 Standard A/P
1	Brown	24 V DC output (auxiliary voltage for reset button)
2	White	Output Reset required
3	Blue	0 V DC
4	Black	Reset/restart interlock
5	Grey	Reserved

- Notes**
- The Reset connection is an additional connection. It is on the receiver.
  - It is not available for M4000 devices with integrated AS-Interface Safety at Work.

### 6.3 External device monitoring (EDM)

The external device monitoring (EDM) checks if the contactors actually de-energize when the protective device responds. If, after an attempted reset, the EDM does not detect a response from the switched devices within 300 ms, the EDM will deactivate the output signal switching devices again.

Fig. 33: Connecting the contact elements to the EDM

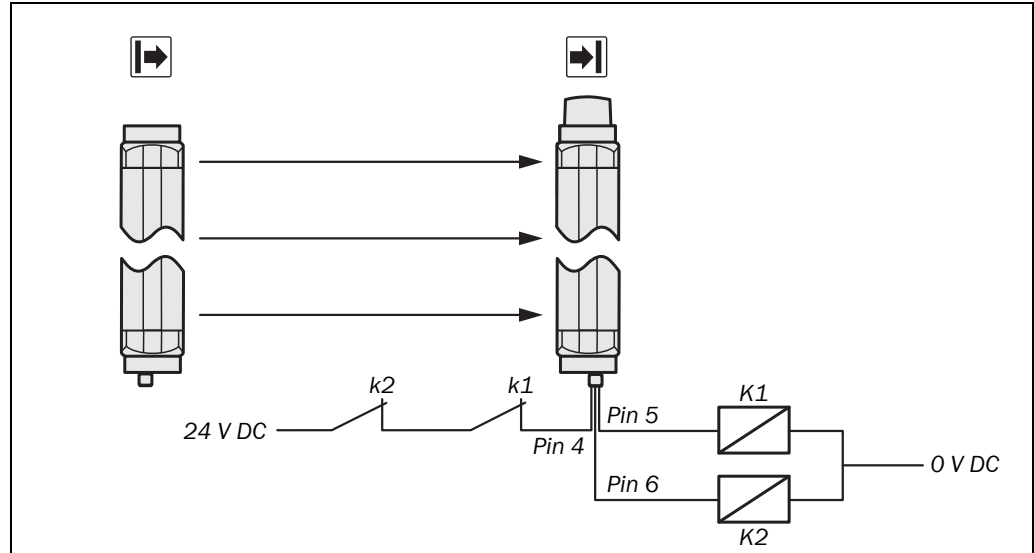

You must implement the external device monitoring electrically by the positively guided closing action of both N/C contacts (k1, k2) when the contact elements (K1, K2) reach their de-energized position after the protective device has responded. 24 V is then applied at the input of the EDM. If 24 V is not present after the response of the protective device, then one of the contact elements is faulty and the external device monitoring prevents the machine starting up again.

#### Notes



- If you connect the contact elements to be monitored to the EDM input, then you must activate the EDM function with the aid of the configuration buttons. If not, the device will show the error .
- If you later deselect the EDM option, pin 4 of the system plug must not remain connected to 24 V.

### 6.4 Reset button/restart button

In the protective operation mode with internal restart interlock (see page 21) the operator must first press the reset button before restarting.



WARNING

#### Select the correct installation site for the reset button!

Install the reset button outside the hazardous area such that it cannot be operated from inside the hazardous area. When operating the reset button, the operator must have full visual command of the hazardous area.

#### Recommendation

You can reduce the wiring effort by connecting the reset button directly to the optional connection *Reset* on the receiver (see Fig. 35 and section 6.2.2 “Connection *Reset* M12 × 5” on page 51).

**M4000 Std., Std. A/P**

Fig. 34: Connecting the reset/restart button

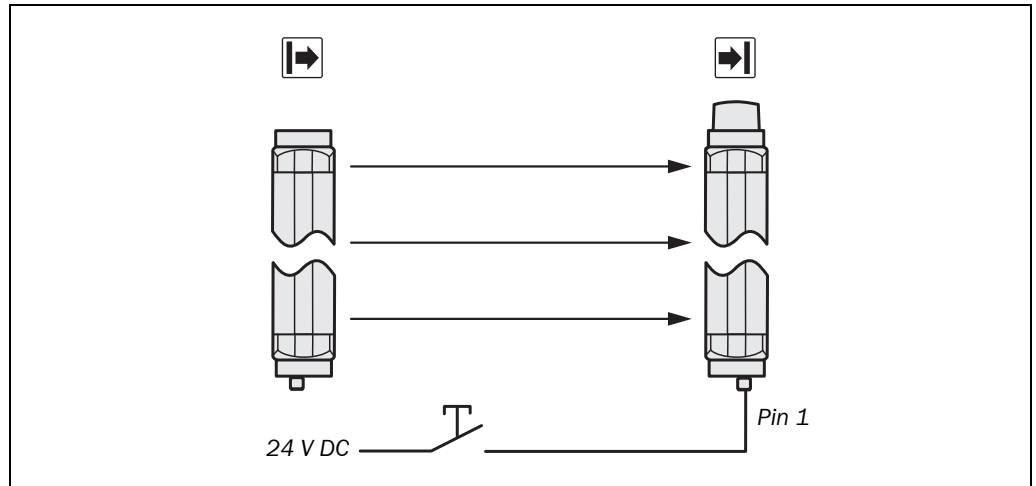
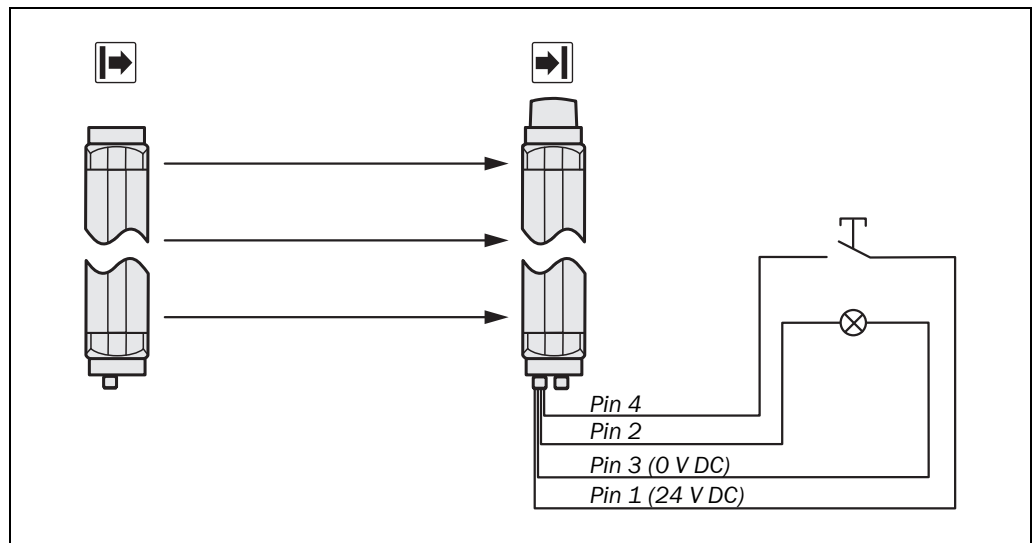

Fig. 35: Connection of the reset button and the signal lamp "Reset required" to the optional "reset" connection



WARNING

**Device configuration after replacement!**

If you replace a multiple light beam safety device with activated *Reset* function with a replacement device, you must check the configuration of the new device (see chapter 8 "Configuration" on page 69ff.). The configuration of the multiple light beam safety device depends on the type and may need to be adapted by re-configuring. It is not enough to only make the electrical connections.

**Connection of a *Reset required* signal lamp**

- Application diagnostic output (ADO):  
Pin 3 of the system connection can be used as *Reset required* output (24 V) (see the following chapter 6.5 "Application diagnostic output (ADO)"). The output has a frequency of 1 Hz.
- To the optional *Reset* connection:  
Pin 2 of the optional *Reset* connection is the *Reset required* output (24 V). You can connect a signal lamp here to indicate this status. The output has a frequency of 1 Hz.

## 6.5 Application diagnostic output (ADO)

Pin 3 on the system plug is an application diagnostic output (ADO). You can use this output for a relay or a PLC.

Fig. 36: Connection to the application diagnostic output

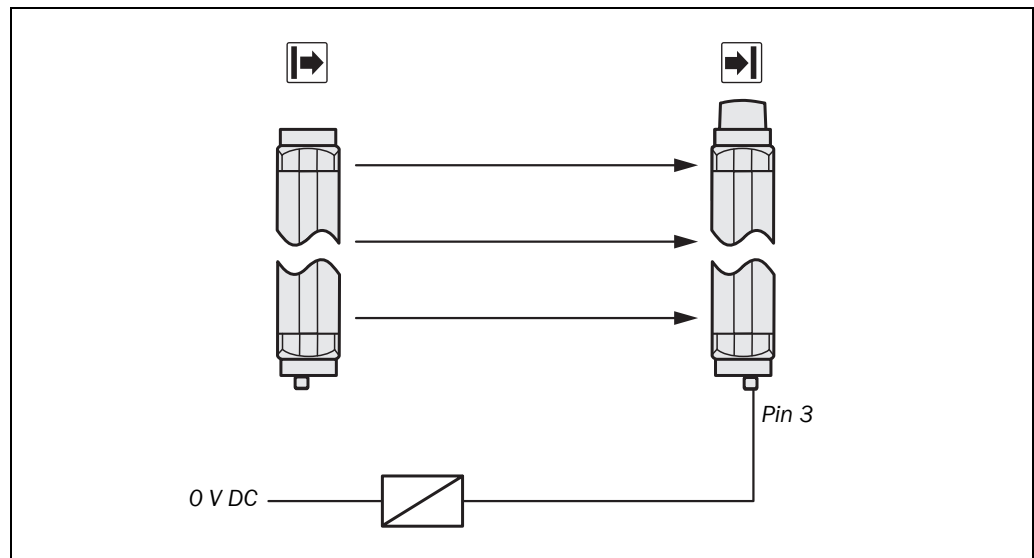

- Notes**
- When you connect the application diagnostic output as an alarm signal for contamination (OWS) or for the OSSD status, then during the configuration you can choose how the application diagnostic output is to signal the alarm.
    - HIGH active: If there is contamination or if the OSSDs are switched on, 24 V are present. Otherwise the output is high resistance.
    - LOW active: If there is contamination or if the OSSDs are switched on, the output is high resistance. Otherwise 24 V are present<sup>3)</sup>.
  - If you use the application diagnostic output as an alarm signal for “Reset required”, it has a frequency of 1 Hz.



If you connect the application diagnostic output, then you must configure it with the aid of the configuration buttons prior to commissioning. Details can be found in chapter 4.3 “Application diagnostic output (ADO)” on page 24.



WARNING

### Device configuration after replacement!

If you replace a multiple light beam safety device on which the application diagnostic output (ADO) is connected and configured, then you must check the configuration of the new device (see chapter 8 “Configuration” on page 69ff.). The configuration of the multiple light beam safety device depends on the type and may need to be adapted by re-configuring. It is not enough to only make the electrical connections.

<sup>3)</sup> With external device monitoring activated, the OSSD status function cannot be configured as **active LOW**.

**6.6 Test input (sender test)**

**Note** The function Sender test is not available with the M4000 Standard A/P.

Fig. 37: Connection of the sender test button

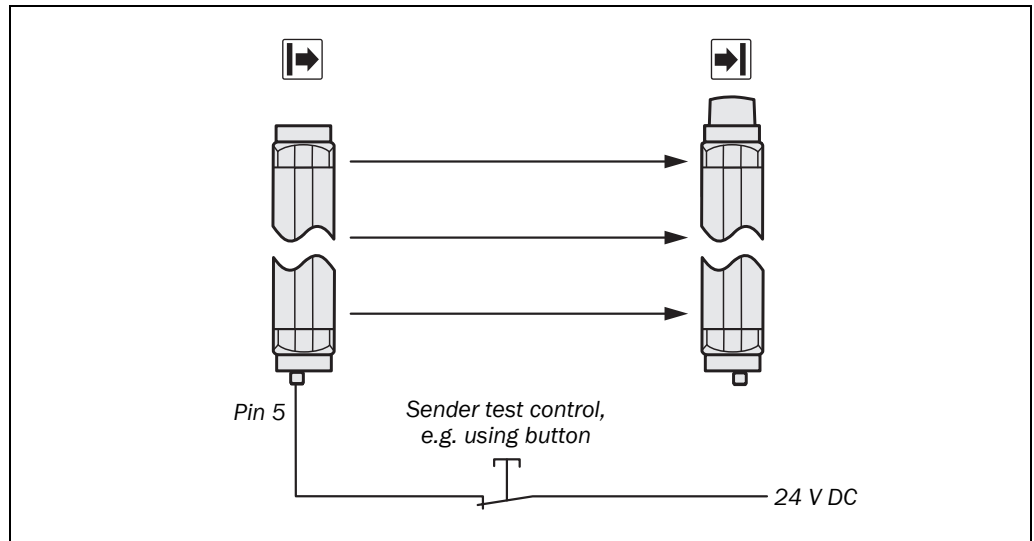

The sender test is performed when 0 V is present at the test input (pin 5) of the sender.

If you connect the sender test, then you must configure it with the aid of the configuration buttons prior to commissioning. Details can be found in chapter 4.6 “Sender test” on page 28.

# 7 Commissioning



WARNING

## Commissioning requires a thorough check by qualified safety personnel!

Before you operate a system protected by the M4000 multiple light beam safety device for the first time, make sure that the system is first checked and released by qualified safety personnel. Please read the notes in chapter 2 “On safety” on page 9.

## 7.1 Display sequence during start-up

After the system is activated, sender and receiver go through a power-up cycle. The 7-segment display indicates the device status during the power-up cycle.

The indications have the following meaning:

Tab. 18: Displays shown during the power-up cycle

Display	Meaning
	Testing the 7-segment display. All segments are activated sequentially.
	Ca. 0.5 s. Is displayed only at the receiver and only in operation with large scanning range.
	Ca. 0.5 s. Non-coded operation or operation with code 1 or 2
	Receiver only: Sender-receiver alignment is not optimal (see section 7.3.1 “Meaning of the 7-segment display during alignment” on page 57ff.).
	It is possible to open the configuration until this symbol appears.
	Only on devices with integrated AS-Interface Safety at Work: Appears when the M4000 is aligned and there is a temporary AS-Interface error. See chapter 10 “Fault diagnosis” on page 75.
Other display	Device error. See chapter 10 “Fault diagnosis” on page 75.

## 7.2 Commissioning the M4000 with integrated AS-Interface Safety at Work in AS-Interface network

Commissioning the multiple light beam safety device in this case refers to the integration of the switch in the AS-Interface network as a safe AS-Interface slave. The integration is performed both directly at the device and in the AS-Interface network (see following table).

Tab. 19: Overview of the steps for commissioning the M4000

On the M4000	In the AS-Interface network
<ul style="list-style-type: none"> <li>make the electrical connection to the AS-Interface network (for the supply voltage)</li> <li>assignment of a unique address (for the identification of the M4000 in the AS-Interface network)</li> <li>alignment of the M4000</li> </ul>	<ul style="list-style-type: none"> <li>integrate or read the M4000 using the software for the AS-Interface master and the AS-Interface safety monitor</li> </ul>



- Notes**
- The M4000 multiple light beam safety device with integrated AS-Interface can only be connected to the machine controller via the AS-Interface network and the AS-Interface safety monitor.
  - Extensive knowledge of the operation of the AS-Interface safety monitor and its configuration and diagnostics software is a prerequisite for the correct commissioning of the M4000 multiple light beam safety device.
  - During code table teach-in by the AS-Interface safety monitor, the LED on the multiple light beam safety device must be green.
  - The M4000 receives its power supply via the AS-Interface network.

**How to integrate the M4000 in an AS-Interface network:**

- Assign a spare address in the AS-Interface network to the M4000. For this purpose use an AS-Interface addressing device. The addressing is performed using the M12 connection plug. The address for the M4000 can also be set via the AS-Interface master as an alternative. On this topic read the description in the operating instructions for the AS-Interface master.
- Connect the M4000 either with the M12 connection cable and the AS-Interface clip or directly with the AS-Interface clip.
- Check whether there is power at the M4000. The power-up cycle is run through.
- Align the M4000 using the instructions in section 7.3 “Alignment of the M4000”.

**How to integrate the M4000 in an AS-Interface safety monitor:**

- Follow the instructions for the configuration and diagnostics software for the AS-Interface master and the AS-Interface safety monitor. On this topic read the related descriptions in the operating instructions for the AS-Interface master and the AS-Interface safety monitor.

### **7.3 Alignment of the M4000**

After the multiple light beam safety device has been mounted and connected, you must align the sender and receiver precisely in relation to each other.

Alignment is performed by mechanically adjusting the M4000 components. During this process the M4000 is in the alignment mode. You can then see when the optimal alignment is achieved on the 7-segment display on the receiver.

The alignment mode is automatically activated when the multiple light beam safety device is switched on if the light beams are not yet aligned or the light path is interrupted.

**Alignment aids**

You can conveniently and accurately align the devices using a laser alignment aid. An alignment aid is recommended particularly when a M4000 system is used with deflector mirrors (each mirror on the mirror columns must be adjusted).

The following alignment aids are available:

- integrated laser alignment aid per beam (optional, only for M4000 Standard)  
On this subject read the description in chapter 7.3.4 “Alignment of the M4000 Standard with integrated laser alignment aid (optional)” on page 61.
- alignment aid AR60 + adapter for M4000 (see section 12.7 “Accessories” on page 101)  
On this topic read the description in the operating instructions for the “Alignment aid AR60”.

### 7.3.1 Meaning of the 7-segment display during alignment

The 7-segment display on the receiver shows you when the optimal alignment is achieved when you align the light beams (see Tab. 20).

- Notes**
- The beam that is closest to the 7-segment display is termed the first light beam (see Fig. 38 and Fig. 39).
  - Only the first and last light beam are evaluated during alignment.
  - If the optimum alignment (= no display) persists for longer than 2 minutes without the multiple light beam safety device being interrupted, the system automatically deactivates the alignment mode.

#### M4000 Standard

Fig. 38: Illustration of the beam order of the M4000 Standard

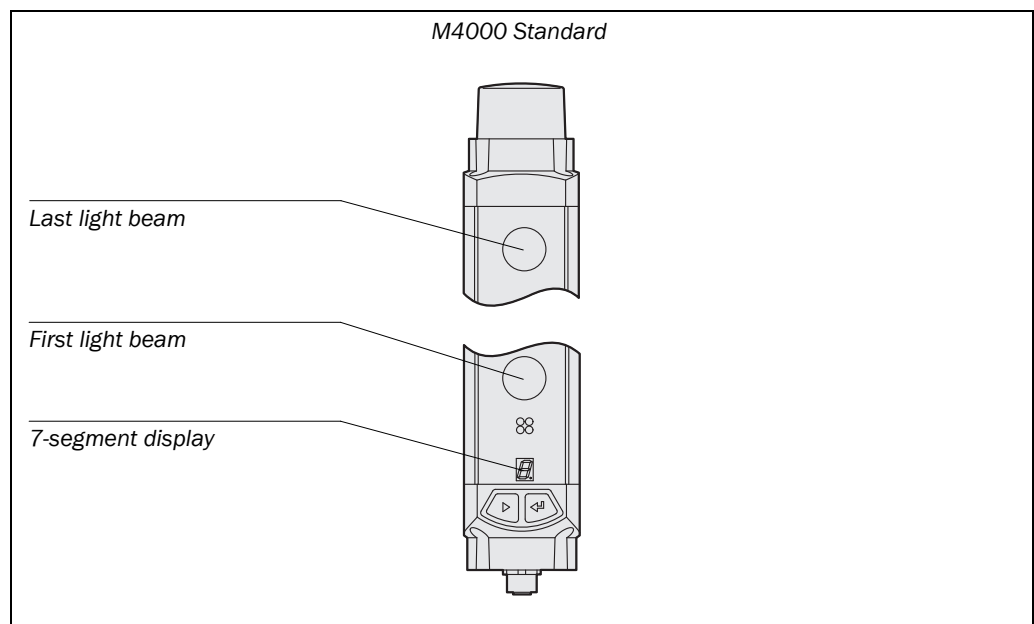

Tab. 20: Indications on the 7-segment display during alignment of the M4000 Standard

Display	Significance during alignment
	First and last light beam not aligned.
	Only the first light beam is aligned.
	Only the last light beam is aligned.
	All the light beams hit the receiver, but the alignment is still slightly off.
No indication and green LED illuminated on the receiver	The alignment is now true; the devices must be locked in this position.

**M4000 Std., Std. A/P**

**M4000 Standard A/P**

Fig. 39: Illustration of the beam order of the M4000 Standard A/P

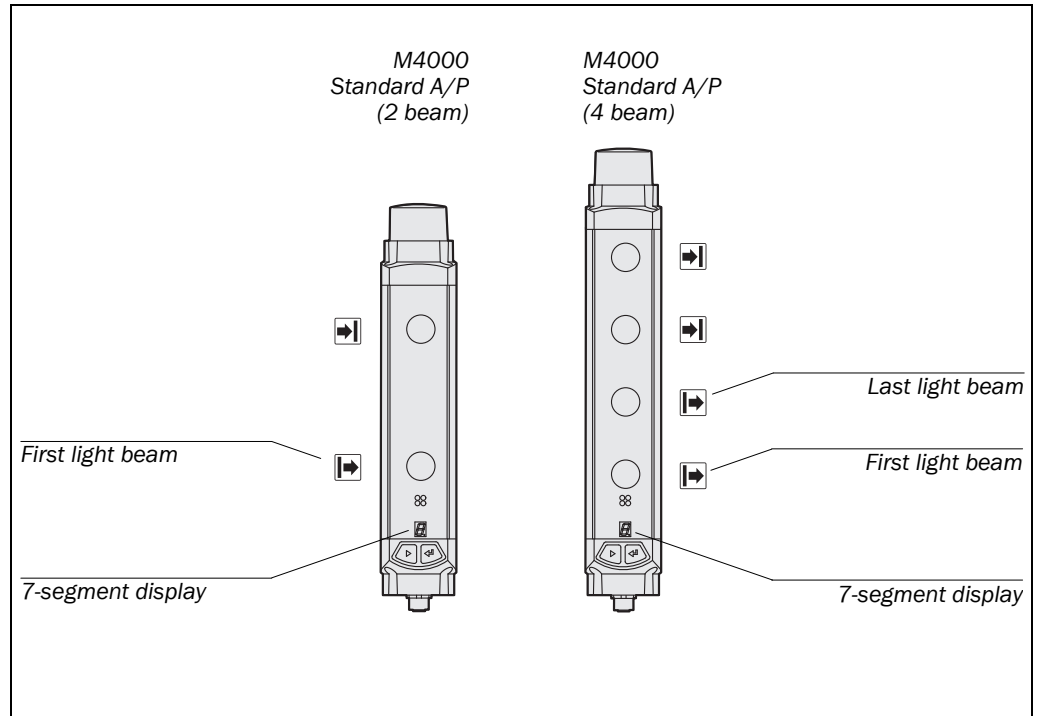

Tab. 21: Indications on the 7-segment display during alignment of the M4000 Standard A/P

Display	Meaning during alignment of the M4000 Standard A/P	
	2 beam	4 beam
	The first light beam is not aligned.	None of the light beams is aligned.
	-	Only the first light beam is aligned.
	-	Only the last light beam is aligned.
	The first light beam is aligned, but the alignment is still slightly off.	All the light beams hit the receiver, but the alignment is still slightly off.
No indication and green LED illuminated	The alignment is now true; the devices must be locked in this position.	

### 7.3.2 Aligning sender and receiver



WARNING

#### Secure the plant/system. No dangerous state possible!

Ensure that the dangerous state of the machine is (and remains) switched off! During the alignment process, the outputs of the multiple light beam safety device are not allowed to have any effect on the machine.

#### How to align sender and receiver in relation to each other:

➤ Check with a spirit level whether the devices and the deflector mirrors, if used, are mounted vertically.

➤ Check whether the following points are the same distance from the floor:

##### M4000 Standard

- first beam of the sender
- first beam of the receiver
- when using deflector mirrors: centre of the first mirror surface

##### M4000 Standard A/P

- first beam of the M4000 Standard A/P
  - centre of the first mirror surface for the M4000 Passive (with mirror deflection) or centre of the first beam for the M4000 Passive (with fibre-optic deflection)
- Loosen the clamping bolts which hold the multiple light beam safety device in place.
- Switch the power supply to the multiple light beam safety device on.
- Watch the alignment information on the 7-segment display of the receiver. Correct the alignment of the sender and receiver (or of the M4000 Standard A/P and the M4000 Passive), until the 7-segment display goes off.
- Fix the multiple light beam safety device using the clamping screws.
- Switch the power supply off and then back on again and check via the 7-segment display whether the alignment is correct after tightening the clamping bolts (see Tab. 20 or Tab. 21).

### 7.3.3 Special aspects of alignment with deflector mirrors

If you use the M4000 multiple light beam safety device with deflector mirrors (mirror columns), then you must note the following points when aligning the mirrors:

1. On the deflection of several beams using a mirror column, each individual mirror must be adjusted separately.
2. For deflection using mirrors, the angle of incidence equals the angle of reflection. This means: A slight rotation of the mirror results in a change that is twice as large (see Fig. 40).

If the light beam is guided to the receiver using a deflector mirror, only part of the original diverging beam is passed on.

The alignment tolerance will become smaller with each further deflection (see Fig. 41).

#### Recommendation

Always use an alignment aid when aligning the M4000 Standard with deflector mirrors (see section "Alignment aids" on page 57).

## M4000 Std., Std. A/P

Fig. 40: Schematic illustration of the change on slight rotation of the deflector mirror

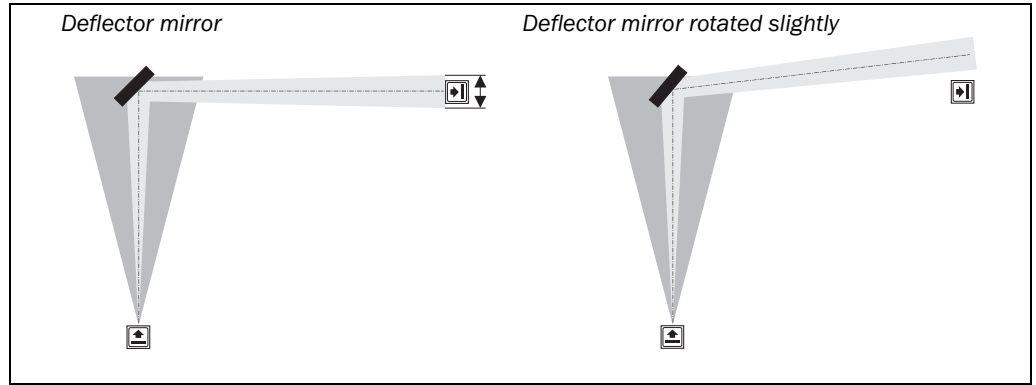
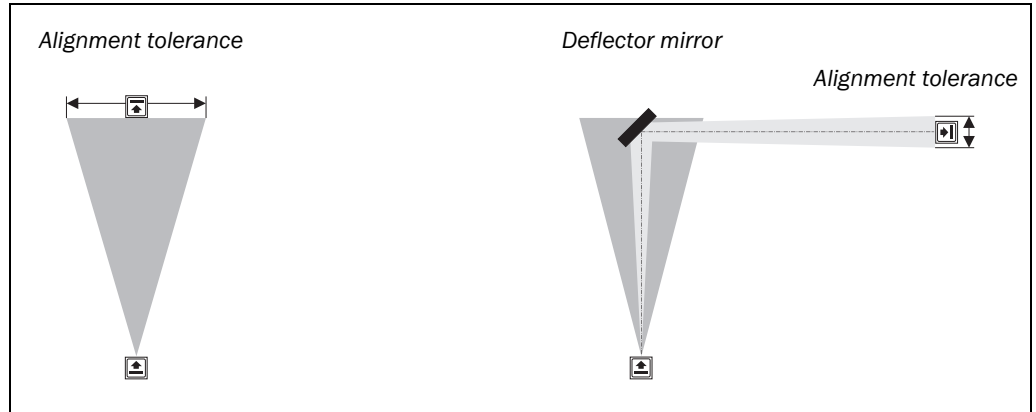

Fig. 41: Schematic illustration of the alignment tolerance without and with deflector mirror



### 7.3.4 Alignment of the M4000 Standard with integrated laser alignment aid (optional)

The multiple light beam safety device is equipped with an integrated laser alignment aid of laser class 2.



WARNING

**Never look directly into the laser beam!**

**Do not point the laser at a person's eye at close range!**

The laser beam is not dangerous for the eye in case of accidental, brief exposure (< 0.25 s). There is only a hazard for the eye if the normal blinking reaction to bright light is suppressed. If the laser beam falls on your eye, you must consciously close your eyes or turn away immediately.

**Do not use any other controls or adjustments!**

Caution! Use of controls, adjustments or performance of procedures other than those herein specified may result in hazardous radiation exposure.

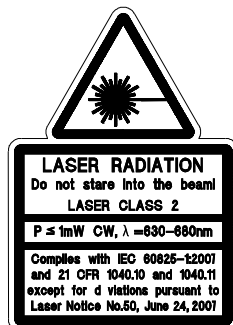

LASER RADIATION  
Do not stare into the beam!  
LASER CLASS 2

$P \leq 1 \text{ mW}$  CW,  $\lambda = 630-680 \text{ nm}$

Complies with IEC 60825-1:2007 and 21 CFR 1040.10 and 1040.11 with the exception of the deviations as per Laser Notice No. 50, June 24, 2007

The M4000 Standard multiple light beam safety device is available with an integrated laser alignment aid as an extra.

The laser alignment aid in conjunction with the indications on the 7-segment display enables you to precisely adjust and align the multiple light beam safety device. The aid comprises a laser per light beam (in the receiver) as well as a laser deflector mirror and a transparent display screen (in the sender).

The laser alignment aid is activated automatically when the M4000 is switched on if the light beams are not aligned or the light path is interrupted.

- Notes**
- Always align the beams individually and in the following order: first beam, second beam ..., last beam (starting at the 7 segment display). When aligning the second and all further beams, it may occur that the laser beams for beams already aligned (e.g. the first beam) are no longer incident to the target on the alignment template (when this is fitted again). This situation has no effect on the accuracy of the overall alignment. I.e. beams already correctly aligned (e.g. first beam) do not need to be re-aligned after the alignment of the next beam (e.g. second beam), even if the laser beam for the beam previously aligned deviates from the target on the alignment template.
  - If the multiple light beam safety device is in the lock-out status when switched on (see section “The lock-out status” on page 75), the laser alignment aid is not activated.
  - The laser alignment aid switches off automatically, ...
    - if the ● **Green** LED on the receiver (light path unoccupied and optimal alignment) is on without interruption for more than 2 minutes.
    - independent of the state after 60 minutes.
  - An activated laser alignment aid can be switched off manually by pressing one of the two configuration buttons for at least one second.
  - In the delivery with the receiver for the M4000 with integrated laser alignment aid you will find two self-adhesive alignment templates (one template for the deflector mirror and one for the sender). Keep both alignment templates at hand. You will find further information on the alignment templates as well as a master for copying in the appendix 13.3.



WARNING

---

#### **Secure the plant/system. No dangerous state possible!**

Ensure that the dangerous state of the machine is (and remains) switched off! During the alignment process, the outputs of the multiple light beam safety device are not allowed to have any effect on the machine.

---

#### **How to align the M4000 Standard with the aid of the integrated alignment aid:**

- Check with a spirit level whether the devices and the deflector mirrors, if used, are mounted vertically.
- Check whether the following points are the same distance from the floor:
  - first beam of the sender
  - first beam of the receiver
  - when using deflector mirrors: centre of the first mirror surface
- Loosen the clamping bolts which hold the multiple light beam safety device in place.
- Adhere the alignment template for mirrors to the individual mirror on the mirror pillar that is used to deflect the beam to be aligned. If you start the alignment with the first beam as per these instructions, this is the bottom mirror on the mirror pillar (see Fig. 43).

**M4000 Std., Std. A/P**

Fig. 42: Attaching the alignment template for mirrors

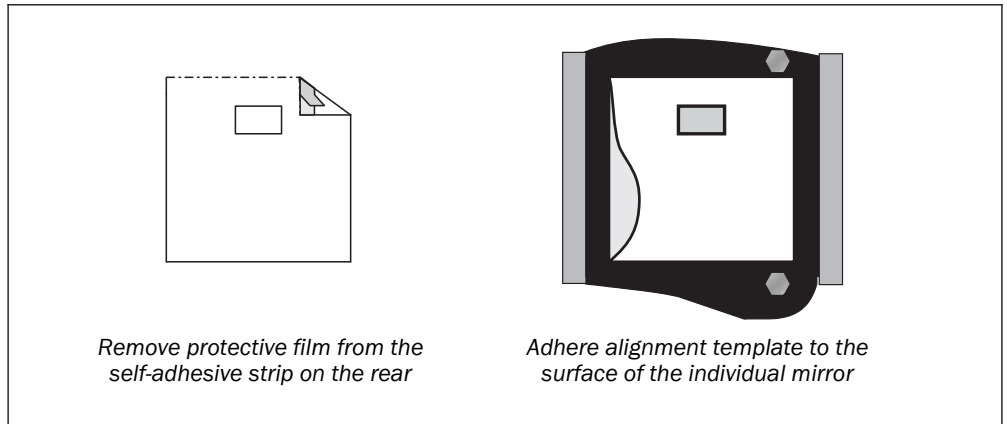

- Activate the laser alignment aid either by switching on the power supply to the multiple light beam safety device or if the M4000 is switched on by pressing one of the two configuration buttons for at least one second.
- Rotate the receiver until the alignment beam is incident in the centre of the hole in the alignment template (see Fig. 43). If further mirror columns are used, use the alignment template for all further mirrors on the mirror columns.

**Note** If you do not use an alignment template, the alignment beam must be incident approx. 23.5 mm above the centre of the mirror.

- Remove the alignment template from the individual mirror.

Fig. 43: Alignment of the receiver to the deflector mirror using the laser alignment aid

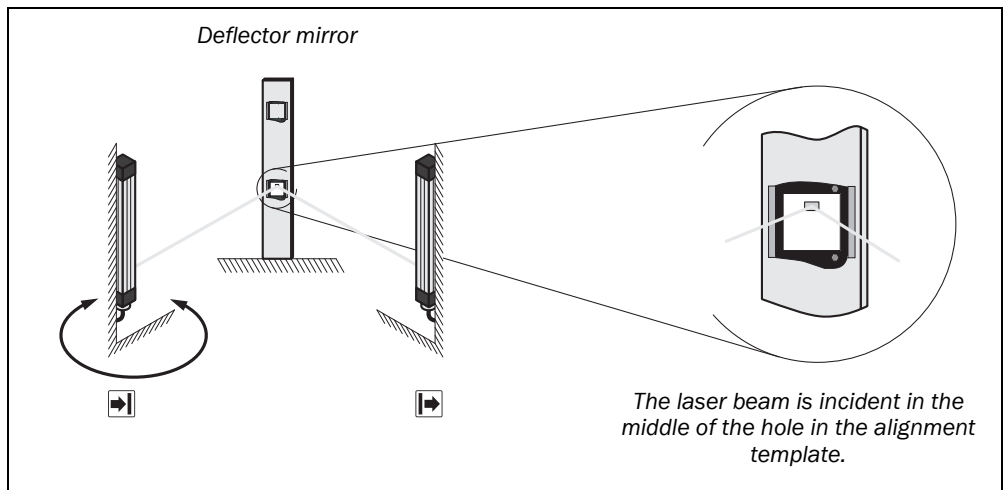

- Adhere the alignment template for the sender to the beam on the sender that is closest to the 7-segment display.

**Note** The alignment template for the sender is correctly positioned on the sender (see Fig. 44), when ...

- the circular opening is exactly over the beam optics

**and**

- the tabs on the template are exactly positioned on the edges of the sender housing and point upward from the 7-segment/LED display.

Fig. 44: Attach the alignment template to the sender

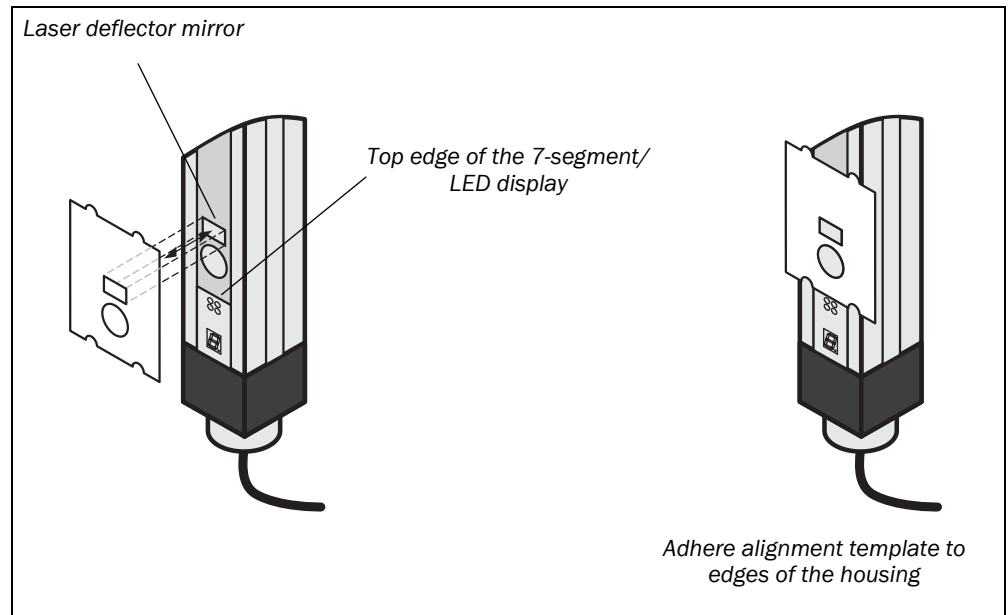

- Align the deflector mirror (depending on the mirror column, you may need to remove the cover plate first). With the aid of three adjusting screws, you can finely adjust the individual mirror (see Fig. 45). The optimal alignment is achieved when the alignment beam is incident in the middle of the rectangular hole in the alignment template.

Fig. 45: Alignment of the deflector mirror to the sender using the laser alignment aid

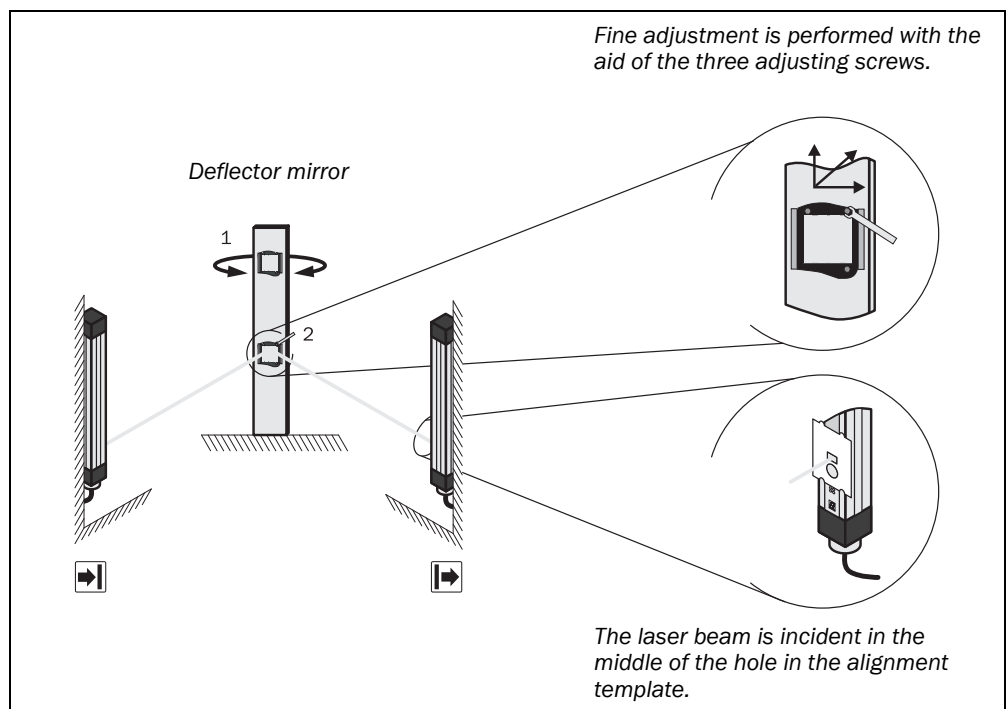

- Note** For the alignment of the sender, the laser beam is deflected within the sender onto a transparent display screen with the aid of the laser deflector mirror. As soon as correct alignment is achieved, the display screen, which can be seen from the exterior, illuminates (see Fig. 46).



**M4000 Std., Std. A/P**

Fig. 46: Principle of laser deflection in the sender

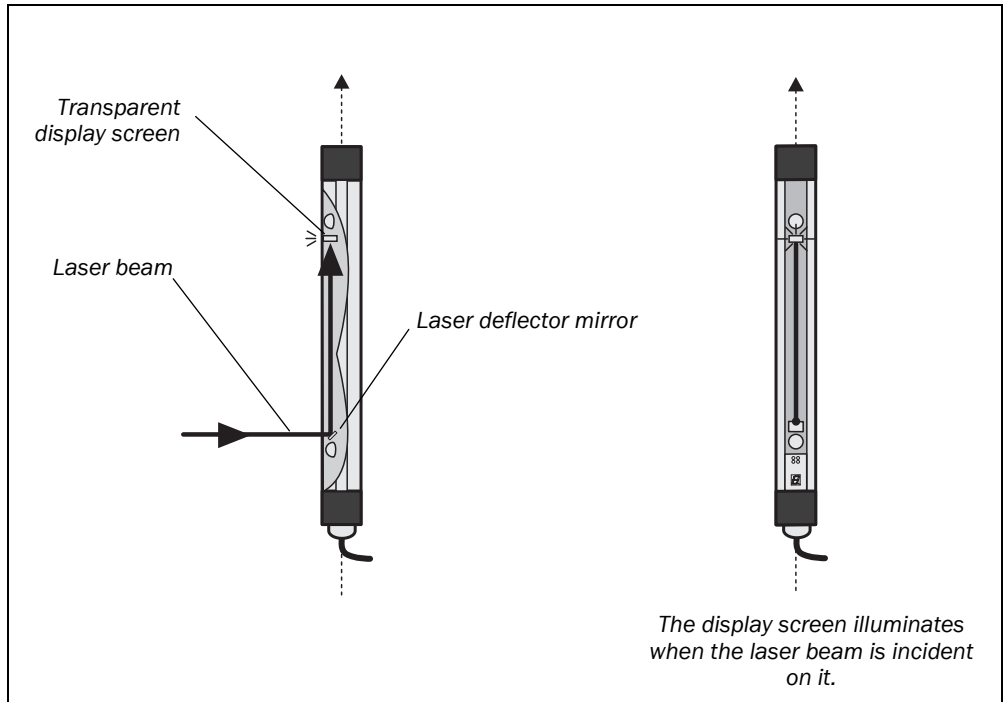

➤ Rotate the sender until the display screen illuminates.

Fig. 47: Alignment of the sender using the laser alignment aid

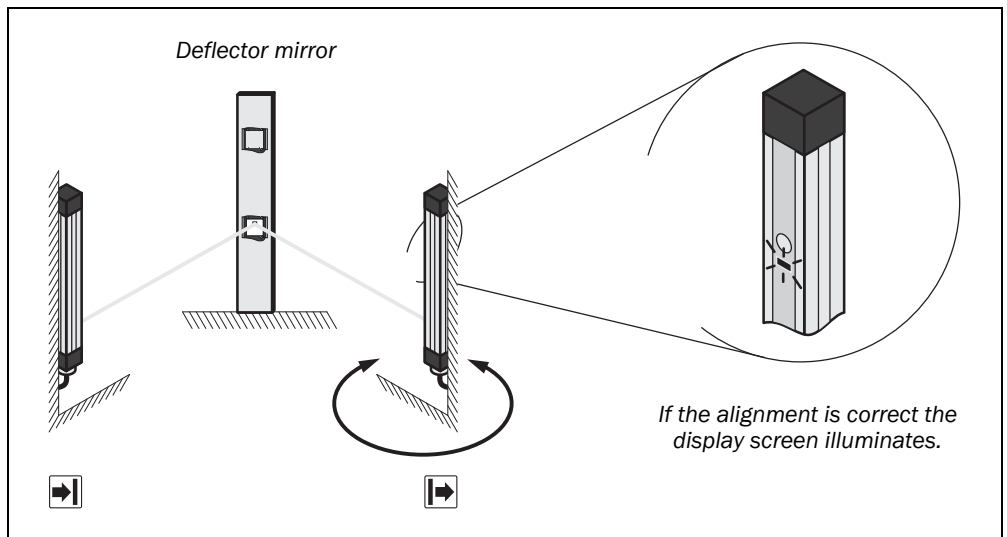

➤ Remove the alignment template. Watch the alignment information on the 7-segment display of the receiver (see Tab. 20). The optimal alignment of the beam near the 7-segment display is achieved when a  appears on the 7-segment display.

- Notes**
- When the alignment information on the 7-segment display goes out (no indication), then all other beams are already aligned.
  - The sender is only aligned once. This step is not necessary when aligning other beams.
- Fix the sender in place.
- Align the other beams using the steps described.

**Note** When aligning the second and all further beams, it may occur that the laser beams for beams already aligned (e.g. the first beam) are no longer incident to the target on the alignment template (when this is fitted again). This situation has no effect on the accuracy of the overall alignment.

- Using the clamping bolts, fix the receiver in place.
- Switch the power supply off and then back on again and check via the 7-segment display whether the alignment is correct after tightening the clamping bolts (see Tab. 20).

**Note** All alignment templates used must be removed after the alignment procedure!

## 7.4 Test notes

Check the protective device as described below and in accordance with the applicable standards and regulations.

These tests are also used to identify if the protection is affected by external light sources or other unusual ambient effects.

These tests must therefore always be performed.

### 7.4.1 Pre-commissioning test notes



WARNING

**Ensure that you do not place anybody at risk during initial commissioning of the machine!**

Always expect that the machine, plant or the protective device does not yet behave as you have planned.

- Ensure that there are no persons in the hazardous area during initial commissioning.
- Check the effectiveness of the protective device mounted to the machine, using all selectable operating modes as specified in the checklist in the annex (see 13.2 on page 104).
- Ensure that the operating personnel of the machine protected by the multiple light beam safety device are correctly instructed by qualified safety personnel before being allowed to operate the machine. Instructing the operating personnel is the responsibility of the machine owner.
- Annex 13.2 of this document shows a checklist for review by the manufacturer and OEM. Use this checklist as a reference before commissioning the system for the first time.

### 7.4.2 Regular inspection of the protective device by qualified safety personnel

- Check the system following the inspection intervals specified in the national rules and regulations. This procedure ensures that any changes on the machine or manipulations of the protective device after the first commissioning are detected.
- If major changes have been made to the machine or the protective device, or if the multiple light beam safety device has been modified or repaired, check the plant again as per the checklist in the annex.

### 7.4.3 Daily functional checks of the protective device

The effectiveness of the protective device must be checked daily or prior to the start of work by a specialist or by authorised personnel, using the correct test rod.



WARNING

#### Do not operate the machine if the green or yellow LED is lit during the test!

If the green or yellow LED lights up during the test even for a short period, work must stop at the machine. In this case the installation of the multiple light beam safety device must be checked by qualified safety personnel (see chapter 5 and 6).

#### Testing the light path between sender and receiver

➤ **Prior** to covering each light beam with a test rod, check whether ...

- the green LED lights up on the M4000 with de-activated internal restart interlock.
- the yellow LED lights up on the M4000 with activated internal restart interlock (“Reset required”).

**Note** If this is not the case, ensure that this condition is reached. The test is otherwise meaningless.

#### Only M4000 Standard:

➤ Completely cover each light beam with a test rod that is not transparent to light (at least 30 mm diameter) at the following positions:

- immediately in front of the sender
- in the middle between sender and receiver (or between the deflector mirrors)
- immediately in front of the receiver
- when using deflector mirrors: immediately before and after the deflector

#### Only M4000 Standard A/P:

➤ Completely cover each light beam with a test rod that is not transparent to light (at least 30 mm diameter). Hold the test rod in the following positions with your arm outstretched:

- immediately in front of the M4000 Standard A/P
- in the middle between M4000 Standard A/P and M4000 Passive or another mirror deflection (e.g. deflector mirror PSK45)
- immediately in front of the M4000 Passive or another mirror deflection (e.g. deflector mirror PSK45)
- when using deflector mirrors between M4000 Standard A/P and M4000 Passive: immediately before and after the deflector

#### This must produce the following result:

- On the receiver for the related multiple light beam safety device only the red LED is allowed to illuminate and **not** the green or yellow LED

**and**

- as long as the light beam is interrupted, it must not be possible to initiate the dangerous state.

**Further tests**

- Check the protective device for damage or wear, particularly the mounting, the electrical connection and the connection cable, the housing and the front screen.
- Check whether the access to the hazardous area is only possible by interrupting the light path between sender and receiver of the M4000 system (e.g. correct mounting of mechanical protective devices).
- Check whether the protective device is effective for the set operating mode.

# 8 Configuration

The chapter contains information on the delivery status of the M4000 and describes how you can change this configuration.

- Notes**
- Only authorised persons are allowed to make changes to the configuration.
  - You can protect the configuration against tampering using a password.

In the following table you will find all functions that can be configured as well as information on which device the functions need to be configured.

You will find more detailed information on the individual functions in chapter 4 “Configurable functions” on page 21ff.

Tab. 22: Overview of the configurable functions

Function	M4000 Standard		M4000 Standard with integrated AS-Interface Safety at Work		M4000 Standard A/P	M4000 Standard A/P with integrated AS-Interface Safety at Work
Beam coding	■	■	■	■	■	■
External device monitoring	-	■	-	-	■	-
Reset/restart interlock	-	■	-	-	■	-
Scanning range	-	■	-	■	■	■
Application diagnostic output (ADO)	-	■	-	-	■	-
Sender test	■	-	-	-	-	-
Password protection	-	■	-	■	■	■

## 8.1 Default delivery status

As delivered the M4000 is configured ready for protective operation.

- Notes**
- The preconfiguration of the M4000 multiple light beam safety device depends on the type (see Ordering information on page 94ff.).
  - You can open the existing configuration of the M4000 on the related device (sender or receiver or M4000 Standard A/P) with the aid of the configuration buttons (see following section).
  - The password protection function is deactivated.

## 8.2 Preparation of the configuration

Before you configure the M4000, you should perform the following steps:

- Make sure that the multiple light beam safety device has been correctly mounted and that the electrical connections are correct and in place.
- Plan all necessary settings (beam coding, scanning range, external device monitoring, etc.) and record them in writing.

### 8.3 Configuration of the M4000

The M4000 multiple light beam safety device is configured with the aid of the two configuration buttons directly on the device. You can read the related setting on the 7-segment display.

The configuration requires three steps:

1. Opening the configuration mode
2. Configure the required functions
3. Saving the configuration

- Notes**
- A cancel during the configuration (e.g. due to a mains power failure) will result in the loss of the newly selected settings. The M4000 automatically uses the last configuration saved after a new start.
  - The significance of the indications given in this section only apply to the configuration mode. If the device is not in the configuration mode, the indications may mean something different.

#### 8.3.1 Opening the configuration mode

- Switch the power supply for the multiple light beam safety device off and on again (e.g. by unplugging the system plug and reinserting it).
- Immediately after switch on (when the power-up cycle starts) simultaneously press, and keep pressed, both configuration buttons until the character (configuration mode active) or (password required) appears.
- If necessary, enter the three-digit password (see Tab. 23).

Tab. 23: Entry of the password on opening the configuration mode



Display	Description
	➤ Choose first number for the password using  button and accept using  button.
	➤ Choose second number for the password using  button and accept using  button.
	➤ Choose third number for the password using  button and accept using  button. <ul style="list-style-type: none"> <li>- If the password is correct,  appears. The device is in the configuration mode.</li> <li>- If the password is incorrect, the error indication  appears. Accept the error using one of the  or  buttons. The device starts a new power-up cycle. Open the Configuration mode again. You can then repeat the entry of the password.</li> </ul>

## 8.3.2 Configure the required functions

The M4000 must be in the configuration mode. The configuration menu has two levels:

- At the *selection level* you choose the function to be configured.
- At the *setting level* you choose the required setting for the related function. The currently configured setting flashes.

### How to configure the required functions:















































- Press the configuration button  (select) several times to page within a menu level.
- Press the configuration button  (enter) to accept the selection made and to change to the other menu level.

When you have selected a function and can now make the setting for this function, the 7-segment display flashes.

Or:



- Press the configuration button  (select) and keep it pressed to display the current setting for the selected function. The 7-segment display indicates in sequence the function, the setting configured and a dot.



Tab. 24: Configuration of the M4000 (menu structure)

	Selection ←  Setting		Meaning
▶ ↓			Configuration mode active
↑ ▶ ↓		  	Beam coding (see page 23) <ul style="list-style-type: none"> <li>• Non-coded</li> <li>• Code 1</li> <li>• Code 2</li> </ul>
↑ ▶ ↓		 	External device monitoring (EDM) (see page 27) <ul style="list-style-type: none"> <li>• Deactivated</li> <li>• Activated</li> </ul>
↑ ▶ ↓		 	Reset/restart interlock (see page 21) <ul style="list-style-type: none"> <li>• Deactivated (external)</li> <li>• Activated (internal)</li> </ul>
↑ ▶ ↓		 	Scanning range (see page 24) <ul style="list-style-type: none"> <li>• Low scanning range</li> <li>• High scanning range</li> </ul>
↑ ▶ ↓		 	Sender test (see page 28) <ul style="list-style-type: none"> <li>• Deactivated</li> <li>• Activated</li> </ul>
↑ ▶ ↓		     	Application diagnostic output (ADO) (see page 24) <ul style="list-style-type: none"> <li>• Deactivated</li> <li>• Contamination (OWS), HIGH active</li> <li>• Contamination (OWS), LOW active</li> <li>• OSSD status, HIGH active</li> <li>• OSSD status, LOW active</li> <li>• Reset required</li> </ul>
↑ ▶ ↓		 	Password protection <ul style="list-style-type: none"> <li>• Deactivated</li> <li>• Activating password protection:                             <ul style="list-style-type: none"> <li>➤ Choose first number ( to ) for the password using  and accept using .</li> <li>➤ Choose second number ( to ) for the password using  and accept using .</li> <li>➤ Choose third number ( to ) for the password using  and accept using .</li> </ul> </li> </ul>
↑ ▶ ↓		 	Quit configuration mode <ul style="list-style-type: none"> <li>• Do <b>not</b> save configuration</li> <li>• Save configuration</li> </ul> When you accept the selection  or  then the 7-segment display indicates  (“configuration mode quit”) (see 8.3.3).



**8.3.3 Saving the configuration**

- In the configuration menu, choose the selection , setting , to save the configuration or setting  to cancel the configuration (see Tab. 24).

The 7-segment display indicates  (“configuration mode quit”). If the 7-segment display indicates  instead of , then the configuration mode has not been quit successfully. In this case please repeat the configuration.

- Press the configuration button  to activate the configuration. The M4000 re-starts the power-up cycle.

## 9 Care and maintenance

The M4000 multiple light beam safety device is maintenance-free. The front screen of the M4000 multiple light beam safety device should be regularly cleaned and also if contaminated.

- Do not use aggressive detergents.
- Do not use abrasive cleaning agents.

**Note** Static charges cause dust particles to be attracted to the front screen. You can prevent this effect by using the antistatic plastic cleaner (SICK Part No. 5600006) and the SICK lens cloth (SICK Part No. 4003353).

### **How to clean the front screen:**

- Use a clean and soft brush to remove dust from the front screen.
- Now wipe the front screen with a clean and damp cloth.

**Note** ➤ After cleaning, check the position of sender and receiver to ensure that the protective device cannot be bypassed (reaching over, under or standing behind).

➤ Verify the effectiveness of the protective device as described in chapter 7.4 "Test notes" on page 66.

# 10 Fault diagnosis

This chapter describes how to identify and remedy errors and malfunctions during the operation of the M4000 multiple light beam safety device.

## 10.1 In the event of faults or errors



WARNING

---

**Cease operation if the cause of the malfunction has not been clearly identified!**

Stop the machine if you cannot clearly identify or allocate the error and if you cannot safely remedy the malfunction.

**Complete function test after rectification of fault!**

After rectifying a fault, perform a complete function test as per section 7.4 “Test notes”.

---

**The lock-out status**

In case of certain faults or an erroneous configuration, the system can go into the lock-out status. The 7-segment display on the multiple light beam safety device then indicates  or a defined error message (see Tab. 26).

➤ First check whether the lock-out status is still present after switching off and on the M4000 (e.g. by disconnecting the system plug and re-connecting).

To place the device back in operation:

➤ Rectify the cause of the fault as per Tab. 26.

➤ Switch the power supply for the M4000 off and on again (e.g. by unplugging the system plug and reinserting it).

**Note** The lock-out status has the highest priority above all other indications on the 7-segment display.

## 10.2 SICK support

If you cannot remedy an error with the help of the information provided in this chapter, please contact your local SICK representative.

### 10.3 Error displays of the LEDs

This chapter explains the meaning of the error displays of the LEDs and how to respond. Please refer to chapter 3.4 “Controls and status indicators” on page 17 for a description.

Tab. 25: Error displays of the LEDs









Display	Possible cause	Remedying the error
<b>☒ Sender</b>		
○ <b>Yellow</b> LED fails to light up	No operating voltage, or voltage too low	➤ Check the voltage supply and activate, if necessary.
<b>☒ Receiver or</b> <b>☒☒ M4000 Standard A/P</b>		
● <b>Orange</b> LED illuminated	Received signal is weak	➤ Check the alignment of sender and receiver or of the M4000 Standard A/P and the M4000 Passive. ➤ Check the front screen (dirt) and clean, if necessary.
● <b>Yellow</b> LED flashing	Reset required	➤ Press the reset button.
○ <b>Red</b> and ○ <b>Green</b> Neither the red nor the green LED lights up	No operating voltage, or voltage too low	➤ Check the voltage supply and activate, if necessary.







### 10.4 Error displays of the 7-segment display

This chapter explains the meaning of the error displays of the 7-segment display and how to respond to the messages. Please refer to chapter 3.4 “Controls and status indicators” on page 17 for a description of the 7-segment display.

Tab. 26: Error displays of the 7-segment display

Display	Possible cause	Remedying the error
0, 1, 2 or 3	Inadequate alignment (in alignment mode)	➤ Re-align sender and receiver (see page 57). The display goes off after 2 minutes.
4	The light path is interrupted (in normal operation)	➤ Rectify the cause of the interruption in the light path.
5	Waiting for configuration or configuration not completed	➤ The display goes off automatically once the configuration has been started. When the display 5 appears when the configuration mode is left: ➤ Switch the device off and on and repeat the configuration of the system (see chapter 8 on page 69).
6 or 7	EDM error (see also page 27)	➤ Check the contactors and their wiring, eliminate any wiring errors, if necessary. ➤ If 7 is displayed, switch the device off and back on again.

Display	Possible cause	Remedying the error
	Reset button fault	<ul style="list-style-type: none"> <li>➤ Check the reset button for correct function. The button may be defective or stuck.</li> <li>➤ Check the wiring of the reset button for any short-circuit to 24 V.</li> </ul>
	Temporary AS-Interface error <ul style="list-style-type: none"> <li>• Commissioning with AS-Interface Address 0</li> <li>• No data traffic</li> <li>• Undefined status message from the integrated AS-Interface</li> </ul>	<ul style="list-style-type: none"> <li>➤ Diagnostics and rectification on the AS-Interface master</li> </ul>
	System error	<ul style="list-style-type: none"> <li>➤ Switch the device off and back on again for at least 3 seconds.</li> </ul> If the error continues to occur: <ul style="list-style-type: none"> <li>➤ Replace the unit (receiver or sender).</li> </ul>
	Overload or peripheral error	<ul style="list-style-type: none"> <li>➤ Switch the device off and back on again for at least 3 seconds.</li> </ul> If the error continues to occur: <ul style="list-style-type: none"> <li>➤ Replace the unit (receiver or sender).</li> </ul>
	Overcurrent at output signal switching device 1	<ul style="list-style-type: none"> <li>➤ Switch the device off and back on again for at least 3 seconds.</li> </ul> If the error continues to occur: <ul style="list-style-type: none"> <li>➤ Check the contactor. Replace, if necessary.</li> <li>➤ Check the wiring for short-circuit to 0 V.</li> </ul>
	Short-circuit at output signal switching device 1	<ul style="list-style-type: none"> <li>➤ Switch the device off and back on again for at least 3 seconds.</li> </ul> If the error continues to occur: <ul style="list-style-type: none"> <li>➤ Check the wiring for short-circuit to 24 V.</li> </ul>
	Short-circuit at output signal switching device 1	<ul style="list-style-type: none"> <li>➤ Switch the device off and back on again for at least 3 seconds.</li> </ul> If the error continues to occur: <ul style="list-style-type: none"> <li>➤ Check the wiring for short-circuit to 0 V.</li> </ul>
	Overcurrent at output signal switching device 2	<ul style="list-style-type: none"> <li>➤ Switch the device off and back on again for at least 3 seconds.</li> </ul> If the error continues to occur: <ul style="list-style-type: none"> <li>➤ Check the contactor. Replace, if necessary.</li> <li>➤ Check the wiring for short-circuit to 0 V.</li> </ul>

Display	Possible cause	Remedying the error
	Short-circuit at output signal switching device 2	<ul style="list-style-type: none"> <li>➤ Switch the device off and back on again for at least 3 seconds.</li> <li>If the error continues to occur:</li> <li>➤ Check the wiring for short-circuit to 24 V.</li> </ul>
	Short-circuit at output signal switching device 2	<ul style="list-style-type: none"> <li>➤ Switch the device off and back on again for at least 3 seconds.</li> <li>If the error continues to occur:</li> <li>➤ Check the wiring for short-circuit to 0 V.</li> </ul>
	Short-circuit between output signal switching device 1 and 2	<ul style="list-style-type: none"> <li>➤ Switch the device off and back on again for at least 3 seconds.</li> <li>If the error continues to occur:</li> <li>➤ Check the wiring and rectify the error.</li> </ul>
	Invalid configuration of the EDM	<ul style="list-style-type: none"> <li>➤ Switch the device off and back on again for at least 3 seconds.</li> <li>If the error continues to occur:</li> <li>➤ Check whether the machine-side EDM is connected but not activated in the configuration.</li> </ul>
	Unknown sender detected	<ul style="list-style-type: none"> <li>➤ Switch the device off and back on again for at least 3 seconds.</li> <li>If the error continues to occur:</li> <li>➤ Check the distance from reflective surfaces (page 35) or from other multiple light beam safety devices.</li> <li>➤ If necessary, re-configure the device with another beam coding (page 23) or install non-reflective partitions.</li> </ul>
	Supply voltage error	<ul style="list-style-type: none"> <li>➤ Switch the device off and back on again for at least 3 seconds.</li> <li>If the error continues to occur:</li> <li>➤ Check whether the power supply complies with the specification (see page 79).</li> <li>➤ Check whether the cable lengths comply with the specification (see page 79, the cable lengths must not be exceeded).</li> </ul>

# 11 Technical specifications

## 11.1 Data sheet

### 11.1.1 M4000 Standard and M4000 Standard A/P

Tab. 27: Data sheet  
M4000 Standard and  
M4000 Standard A/P

	Minimum	Typical	Maximum
<b>General system data</b>			
Type	Type 4 (IEC 61496-1)		
Safety Integrity Level <sup>4)</sup>	SIL3 (IEC 61508)		
SIL claim limit <sup>4)</sup>	SILCL3 (EN 62061)		
Category	Category 4 (EN ISO 13849-1)		
Performance Level <sup>4)</sup>	PL e (EN ISO 13849-1)		
PFHd (mean probability of a dangerous failure per hour)	$6.6 \times 10^{-9}$		
T <sub>M</sub> (mission time)	20 years (EN ISO 13849)		
Number of beams, type-dependent			
M4000 Standard	2		12
M4000 Standard A/P	2		4
Beam separation, type-dependent			
M4000 Standard	120 mm		600 mm
M4000 Standard A/P		500 mm and 300 mm	
Scanning range, configurable			
M4000 Standard			
Low scanning range	0.5 ... 20 m		
High scanning range	9 ... 70 m	9 ... 90 m <sup>5)</sup>	
Scanning range <sup>6)</sup>			
M4000 Standard A/P			
With mirror deflection	0.5 m		7.5 m
With fibre-optic deflection	0.5 m		4.5 m
Beam diameter	23 mm		
Protection class <sup>7)</sup>	III (EN 50178)		
Enclosure rating	IP 65 (EN 60529)		
Supply voltage V <sub>S</sub> at device <sup>8)</sup>	19.2 V	24 V	28.8 V

<sup>4)</sup> For detailed information on the exact design of your machine/system, please contact your local SICK representative.

<sup>5)</sup> On the utilisation of this protective field width, it must be expected the orange LED will illuminate (cleaning or alignment required). The system then only has a reserve of 30%.

<sup>6)</sup> The scanning range of the M4000 Standard A/P device must be configured to suit the deflection used (see section 4.4.2 "Scanning range of the M4000 Standard A/P" on page 26).

<sup>7)</sup> Safety extra-low voltage SELV/PELV.

<sup>8)</sup> The external voltage supply must be capable of buffering brief mains voltage failures of 20 ms as specified in EN 60204-1. Suitable power supplies are available as accessories from SICK (Siemens type series 6 EP 1).

	Minimum	Typical	Maximum
Residual ripple <sup>9)</sup>			±10%
Synchronisation <sup>10)</sup>	Optical, without separate synchronisation		
Power-up delay of sender and receiver before ready			10 s

#### ➤ Sender

Test input			
Input voltage <sup>11)</sup> HIGH (active)	11 V	24 V	30 V
Input current HIGH	7 mA	10 mA	20 mA
Switching voltage LOW (inactive)	-30 V	0 V	5 V
Input current LOW <sup>11)</sup>	-3.5 mA	0 mA	0.5 mA
Response time to test	Depending on the number of beams, maximum 150 ms		
Wavelength of sender <sup>12)</sup>	Near infrared (NIR), invisible <sup>13)</sup>		
power consumption			0.2 A
Weight, type-dependent	See section 11.2 "Table of weights" on page 85ff.		

#### ➤ Receiver or ➤ ➤ M4000 Standard A/P

Output signal switching devices (OSSDs)	2 PNP semiconductors, short-circuit protected <sup>14)</sup> , cross-circuit monitored		
Response time			
2 to 6 beams	10 ms		
7 to 11 beams	11 ms		
12 beams	12 ms		
Switch off time	100 ms		
Power-up delay			6.5 × response time
Switching voltage <sup>11) 15)</sup> HIGH (active, $U_{eff}$ )	$V_s - 2.25 V$	24 V	$V_s$
Switching voltage LOW (inactive)	0 V	0 V	2 V
Switching current	0 mA		500 mA
Leakage current <sup>16)</sup>			0.25 mA
Load capacity			2.2 μF
Switching sequence	Depending on load inductance		
Load inductance <sup>17)</sup>			2.2 H

<sup>9)</sup> Within the limits of  $V_s$ .

<sup>10)</sup> Only with Active/Active systems.

<sup>11)</sup> As per IEC 61131-2.

<sup>12)</sup> Only with Active/Active systems.

<sup>13)</sup> For the exact value see [www.sick.com](http://www.sick.com).

<sup>14)</sup> Applies to the voltage range between -30 V and +30 V.

<sup>15)</sup> On the device plug.

<sup>16)</sup> In the case of a fault (0-V cable open circuit) maximally the leakage current flows in the OSSD cable. The downstream controller must detect this status as LOW. A FPLC (fail-safe programmable logic controller) must be able to identify this status.



	Minimum	Typical	Maximum
Test pulse data <sup>18)</sup>			
Test pulse width	120 µs	150 µs	300 µs
Test pulse rate	3 1/s	5 1/s	10 1/s
Permissible cable resistance			
Between device and load <sup>19)</sup>			2.5 Ω
Supply lead			1 Ω
Power consumption			
M4000 Standard			0.6 A <sup>20)</sup>
M4000 Standard A/P			0.6 A <sup>20)</sup>
External device monitoring (EDM) input			
Input voltage <sup>21)</sup> HIGH (inactive)	11 V	24 V	30 V
Input current HIGH	6 mA	10 mA	20 mA
Input voltage <sup>21)</sup> LOW (active)	-30 V	0 V	5 V
Input current LOW	-2.5 mA	0 mA	0.5 mA
Contactors			
Permissible dropout time			300 ms
Permissible reactivation time			300 ms
Control switch input (reset button)			
Input voltage <sup>21)</sup> HIGH (active)	11 V	24 V	30 V
Input current HIGH	6 mA	10 mA	20 mA
Input voltage <sup>21)</sup> LOW (inactive)	-30 V	0 V	5 V
Input current LOW	-2.5 mA	0 mA	0.5 mA
Operation time control switch input	200 ms		
Output <i>Reset required</i> (24 V lamp output)	PNP semiconductors, short-circuit protected <sup>22)</sup>		
Switching voltage HIGH (active)	15 V	24 V	4 W/0.2 A
Switching voltage LOW (inactive)		High resistance	28.8 V

17) The maximum rated load inductance is higher with lower switching sequence.

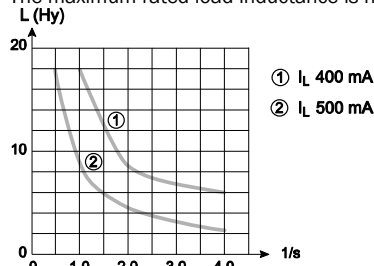

18) When active, the outputs are tested cyclically (brief LOW). When selecting the downstream controllers, make sure that the test pulses do not result in deactivation when using the above parameters.

19) Make sure to limit the individual cable resistance to the downstream controller to this value to ensure that a cross-circuit between the outputs is safely detected. (Also note EN 60 204-1 Electrical Machine Equipment, Part 1: General Requirements.)

20) Without OSSDs, without ADO and without *Reset required*.

21) As per IEC 61 131-2.

22) Applies to the voltage range between -30 V and +30 V.

	Minimum	Typical	Maximum
Application diagnostic output (ADO)	PNP semiconductors, short-circuit protected <sup>22)</sup>		
Switching voltage HIGH (active)	$V_s - 4.2 \text{ V}$	24 V	$V_s$
Switching voltage LOW (inactive)		High resistance	
Switching current	0 mA		100 mA
Wavelength M4000 Standard A/P (sender unit)	Near infrared (NIR), invisible <sup>23)</sup>		
Alignment laser (optional) <sup>24)</sup>	Laser class 2. Complies with IEC 60 825-1:2007 and 21 CFR 1040.10 and 1040.11 with the exception of the deviations as per Laser Notice No. 50, June 24, 2007 Optical power output $\leq 1 \text{ mW}$ Wavelength 630 nm-680 nm (visible red light)		
Weight, type-dependent	See section 11.2 "Table of weights" on page 85ff.		

**Operating data**

Connection	M12 plug, 8-pin		
Cable length <sup>25)</sup>			15 m
Wire cross-section	0.25 mm <sup>226)</sup>		
Ambient operating temperature	-30 °C		+55 °C
Air humidity (non-dewing)	15 %		95 %
Storage temperature	-30 °C		+70 °C
Housing cross-section	52 mm × 55.5 mm		
Vibration resistance	5 g, 10-55 Hz (EN 60 068-2-6)		
Shock resistance	10 g, 16 ms (EN 60 068-2-27)		

**Environmental data, materials**

Housing	Aluminium alloy ALMGSI 0.5 (powder coated)
Front screen	Polycarbonate, scratch-resistant coating
End caps	Polyamide 6.6 CF30
Packaging	Corrugated cardboard with polyethylene inlays
Circuit boards	Glass-fibre reinforced epoxy resin with flame retarding agent TBBPA

**M4000 Passive**

Housing cross-section	52 mm × 55.5 mm
Weight, type-dependent	See section 11.2 "Table of weights" on page 85ff.

<sup>23)</sup> For the exact value see [www.sick.com](http://www.sick.com).

<sup>24)</sup> Below -10 °C the availability of the alignment laser is limited.

<sup>25)</sup> Depending on load, power supply and wire cross-section. The technical specifications must be observed.

<sup>26)</sup> With moulded cable sockets.

## M4000 Std., Std. A/P

### 11.1.2 M4000 Standard and M4000 Standard A/P with integrated AS-Interface Safety at Work interface

Tab. 28: Data sheet  
M4000 Standard and  
M4000 Standard A/P with  
integrated AS-Interface  
Safety at Work

Minimum	Typical	Maximum
---------	---------	---------

#### General system data

Type	Type 4 (IEC 61496-1)		
Safety Integrity Level <sup>27)</sup>	SIL3 (IEC 61508)		
SIL claim limit <sup>27)</sup>	SILCL3 (EN 62061)		
Category	Category 4 (EN ISO 13849-1)		
Performance Level <sup>27)</sup>	PL e (EN ISO 13849-1)		
PFHd (mean probability of a dangerous failure per hour)	$6.6 \times 10^{-9}$		
T <sub>M</sub> (mission time)	20 years (EN ISO 13849)		
Number of beams, type-dependent			
M4000 Standard	2		12
M4000 Standard A/P	2		4
Beam separation, type-dependent	120 mm		600 mm
Scanning range, configurable			
M4000 Standard			
Low scanning range	0.5 ... 20 m		
High scanning range	9 ... 70 m	9 ... 90 m <sup>28)</sup>	
Scanning range			
M4000 Standard A/P	0.5 m		7.5 m
Beam diameter	23 mm		
Protection class	III (EN 50178)		
Enclosure rating	IP 65 (EN 60529)		
Supply voltage V <sub>S</sub> at device <sup>29)</sup>	26 V		31.6 V
Synchronisation <sup>30)</sup>	Optical, without separate synchronisation		
Power-up delay of sender and receiver before ready			10 s

#### ☑ Sender

Wavelength of sender <sup>30)</sup>	Near infrared (NIR), invisible <sup>31)</sup>		
Power consumption			0.2 A
Slave address	Passive bus components, no bus address <sup>32)</sup>		
Weight, type-dependent	See section 11.2 "Table of weights" on page 85ff.		

<sup>27)</sup> For detailed information on the exact design of your machine/system, please contact your local SICK representative.

<sup>28)</sup> On the utilisation of this protective field width, it must be expected the orange LED will illuminate (cleaning or realignment required). The system then only has a reserve of 30%.

<sup>29)</sup> The external voltage supply of the devices must be capable of buffering brief mains voltage failures of 20 ms as specified in EN 60204-1. The voltage supply must also comply with the AS-Interface specification. Suitable power supplies are available as accessories from SICK (Puls, type series SLA 3/SLA 8).

<sup>30)</sup> Only with Active/Active systems.

<sup>31)</sup> For the exact value see [www.sick.com](http://www.sick.com).

<sup>32)</sup> The sender is to be taken into account in the AS-Interface system as a user with the impedance defined in EN 50295.

Minimum	Typical	Maximum
---------	---------	---------

**Receiver or M4000 Standard A/P**

Power consumption			0.2 A
AS-Interface profile	S-0.B.E		
Slave address	Active bus component, address must be programmed in the range 1 to 31, default delivery status: address 0		
Response time	2 to 6 beams      10 ms 7 to 11 beams    11 ms 12 beams            12 ms		
Switch off time	500 ms		
Power-up delay			6.5 × response time
Operating mode	Protective operation without restart interlock		
Wavelength M4000 Standard A/P (sender unit)	Near infrared (NIR), invisible <sup>33)</sup>		
Alignment laser (optional) <sup>34)</sup>	Laser class 2. Complies with IEC 60825-1:2007 and 21 CFR 1040.10 and 1040.11 with the exception of the deviations as per Laser Notice No. 50, June 24, 2007 Optical power output ≤ 1 mW Wavelength 630 nm-680 nm (visible red light)		
Weight, type-dependent	See section 11.2 "Table of weights" on page 85ff.		

**Operating data**

Connection	M12 plug, 4-pin		
Operating temp.	-30 °C		+55 °C
Air humidity (non-dewing)	15 %		95 %
Storage temperature	-30 °C		+70 °C
Housing cross-section	52 mm × 55.5 mm		
Vibration resistance	5 g, 10-55 Hz (EN 60068-2-6)		
Shock resistance	10 g, 16 ms (EN 60068-2-27)		

<sup>33)</sup> For the exact value see [www.sick.com](http://www.sick.com).

<sup>34)</sup> Below -10 °C the availability of the alignment laser is limited.

Minimum	Typical	Maximum
---------	---------	---------

**Environmental data, materials**

Housing	Aluminium alloy ALMGSI 0.5
Front screen	Polycarbonate, scratch-resistant coating
End caps	Polyamide 6.6 CF30
Packaging	Corrugated cardboard with polyethylene inlays
Circuit boards	Glass-fibre reinforced epoxy resin with flame retarding agent TBBPA

**M4000 Passive**

Housing cross-section	52 mm × 55.5 mm
Weight, type-dependent	See section 11.2 “Table of weights” on page 85ff.

**11.2 Table of weights**

**11.2.1 M4000 Standard**

Tab. 29: Table of weights M4000 Standard

Number of beams	Beam separation [mm]	Type code	Weight [g]
2	500	M40Z-0250##### <sup>35)</sup>	1860
		M40#-0250#####	1925
	600	M40#-0260#####	2200
3	220	M40#-0322#####	1760
	400	M40#-0340#####	2750
	450	M40#-0345#####	3025
4	220	M40#-0422#####	2370
	300	M40Z-0430##### <sup>35)</sup>	3040
		M40#-0430#####	3030
5	220	M40#-0522#####	2975
6	220	M40#-0622#####	3580
7	220	M40#-0722#####	4185
8	220	M40#-0822#####	4795

**11.2.2 M4000 Passive**

Tab. 30: Table of weights M4000 Passive

For number of beams	Deflector unit	Part number	Type code	Weight [g]
2	Mirror deflection	1027906	PSD01-1501	1500
	Fibre-optic deflection	1027907	PSD01-2501	1760
4	Fibre-optic deflection	1027908	PSD02-2301	2920

<sup>35)</sup> M4000 Standard A/P.

11.3 Dimensional drawings

11.3.1 M4000 Standard, M4000 Standard A/P

Fig. 48: Dimensional drawing M4000 Standard receiver (sender mirror image) or M4000 Standard A/P (mm)

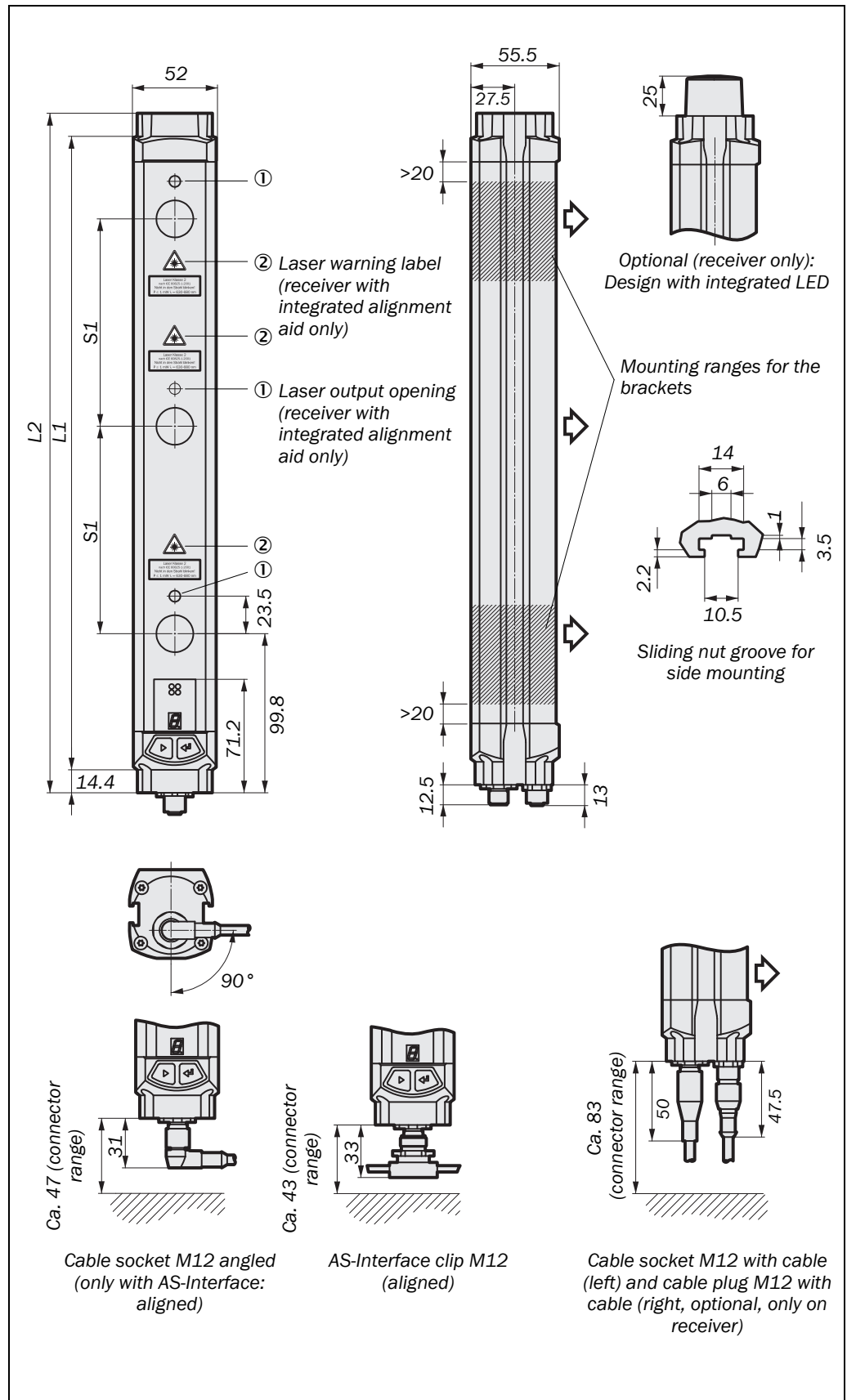

## M4000 Std., Std. A/P

Tab. 31: Dimensions  
dependent on the number of  
beams M4000 Standard

## M4000 Standard

Number of beams	Beam separation S1 [mm]	Dimension L1 [mm]	Dimension L2 [mm]
2	500	643	672
	600	743	772
3	220	583	612
	400	943	972
	450	1043	1072
4	220	803	832
	300	1043	1072
5	220	1023	1052
6	220	1243	1272
7	220	1462	1491
8	220	1682	1711

## M4000 Standard A/P

Number of beams	Beam separation S1 [mm]	Dimension L1 [mm]	Dimension L2 [mm]
2	500	643	672
4	300	1043	1072

**Note** If you use the M4000 Standard (or the M4000 Standard A/P) with optional end cap with integrated LED, the dimension L2 of the receiver increases by 25 mm.

11.3.2 M4000 Passive

Fig. 49: Dimensional drawing M4000 Passive (mm)

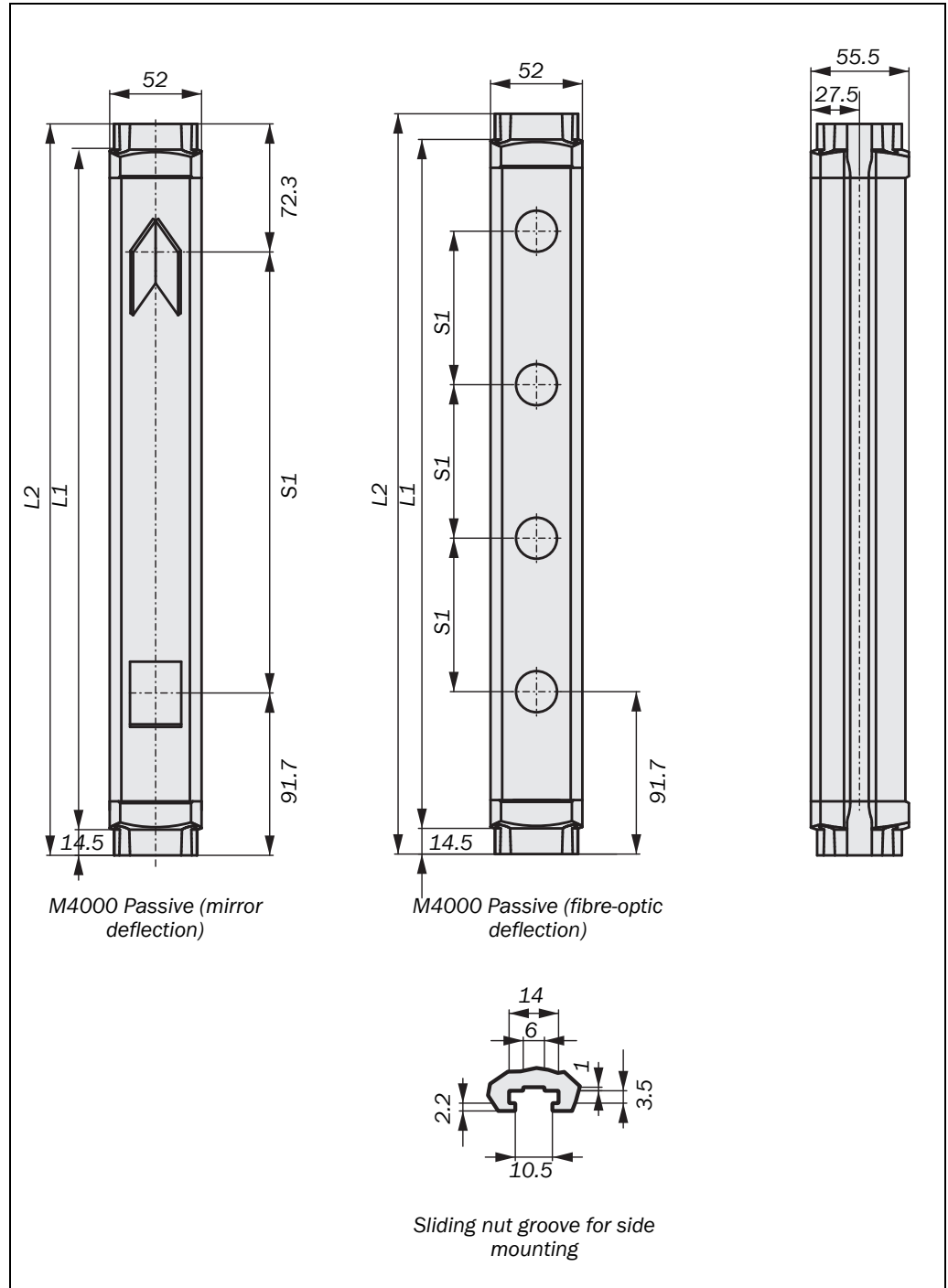



## M4000 Std., Std. A/P

Tab. 32: Dimensions of the M4000 Passive dependent on the number of beams

### M4000 Passive (mirror deflection)

For number of beams	Beam separation S1 [mm]	Dimension L1 [mm]	Dimension L2 [mm]
2	500	635	664

### M4000 Passive (fibre-optic deflection)

For number of beams	Beam separation S1 [mm]	Dimension L1 [mm]	Dimension L2 [mm]
2	500	635	664
4	300	1035	1064

**Notes** If you use a two-beam M4000 Standard A/P, then instead of the M4000 Passive you can use one of the following alternatives:

- two deflector mirrors PSK45 (see section 11.3.9 “Deflector mirror PSK45” on page 93)
- or**
- one mirror column (part number: 1041917, see section 12.5 “Deflector mirrors and mirror columns” page 100)

### 11.3.3 Omega bracket

Fig. 50: Omega bracket (mm)

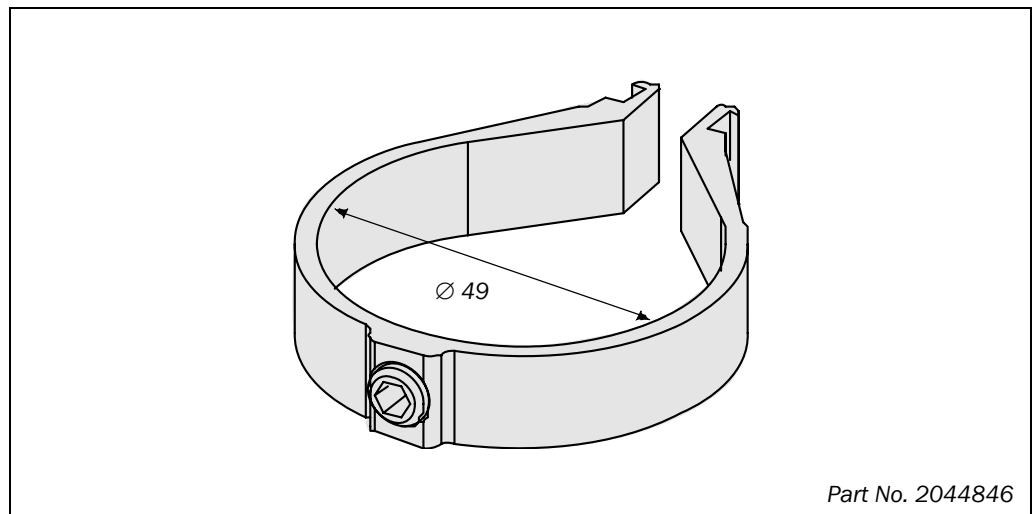

### 11.3.4 Swivel mount bracket

Fig. 51: Dimensional drawing swivel mount bracket (mm)

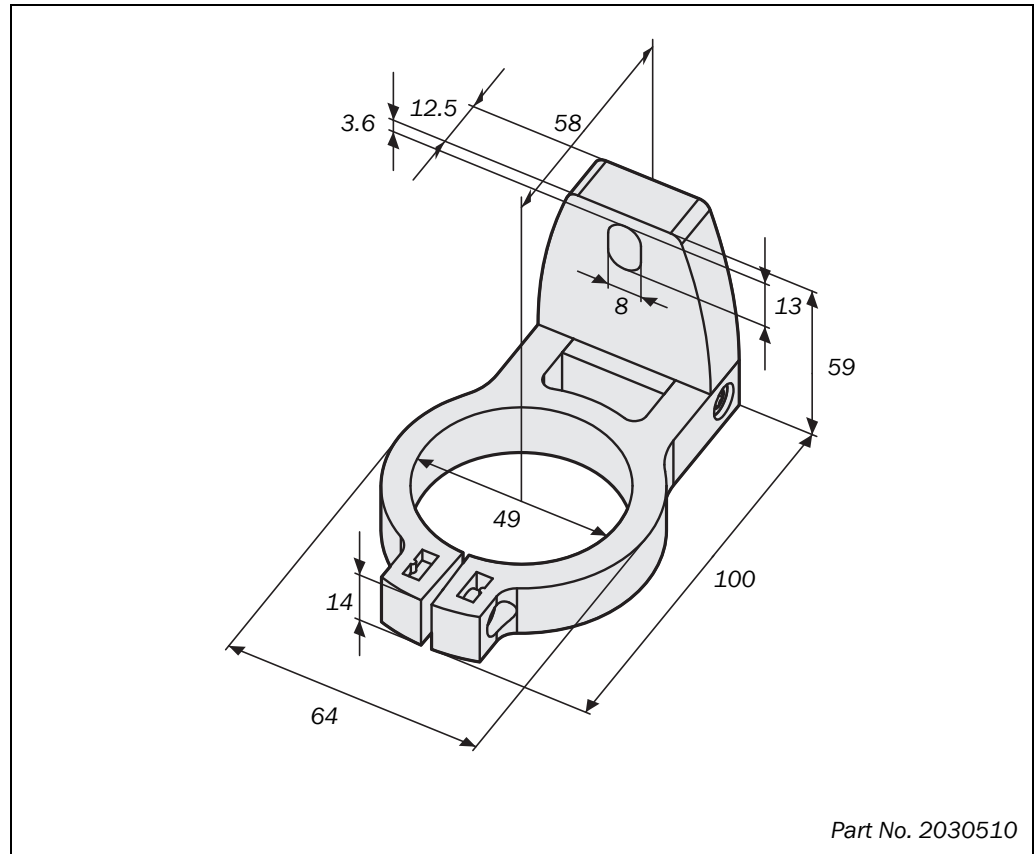

### 11.3.5 Side bracket

Fig. 52: Dimensional drawing side bracket (mm)

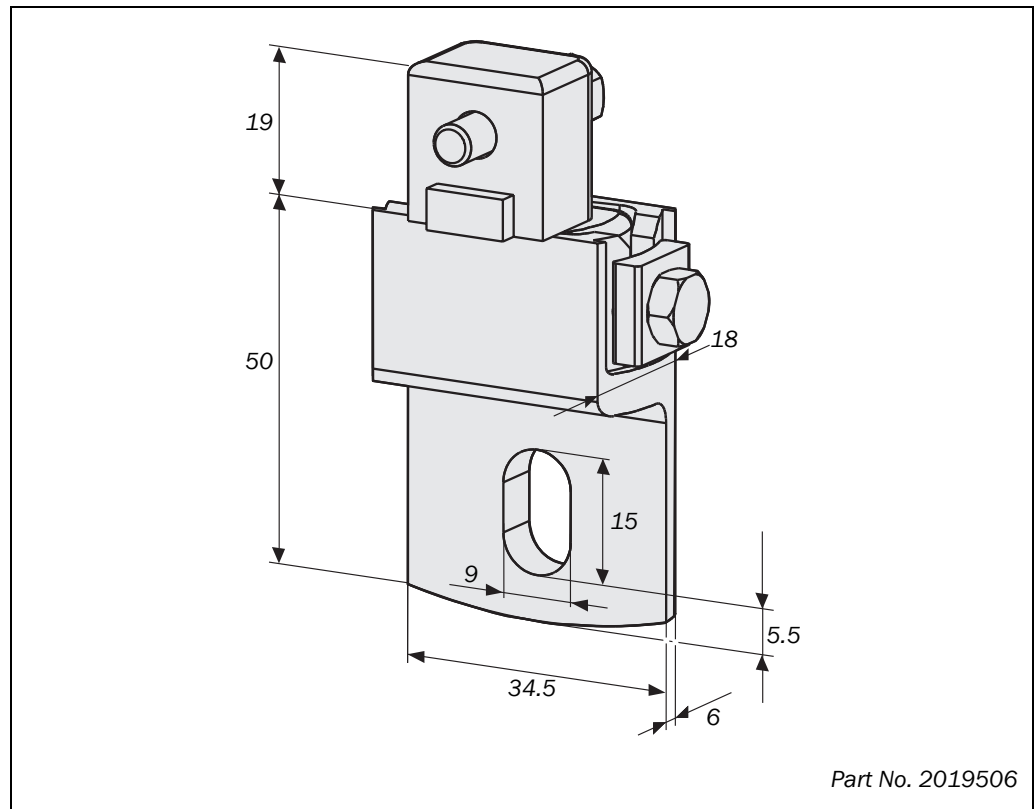

## 11.3.6 Rigid mounting bracket

Fig. 53: Dimensional drawing rigid mounting bracket (mm)

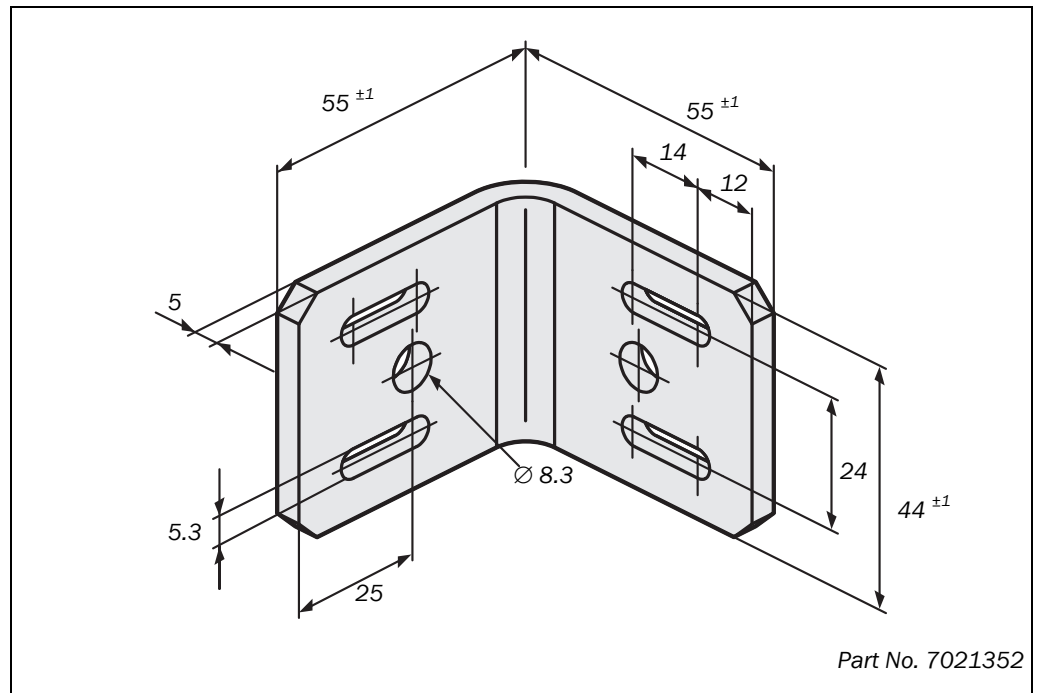

## 11.3.7 Pivoting mounting bracket

Fig. 54: Dimensional drawing pivoting mounting bracket (mm)

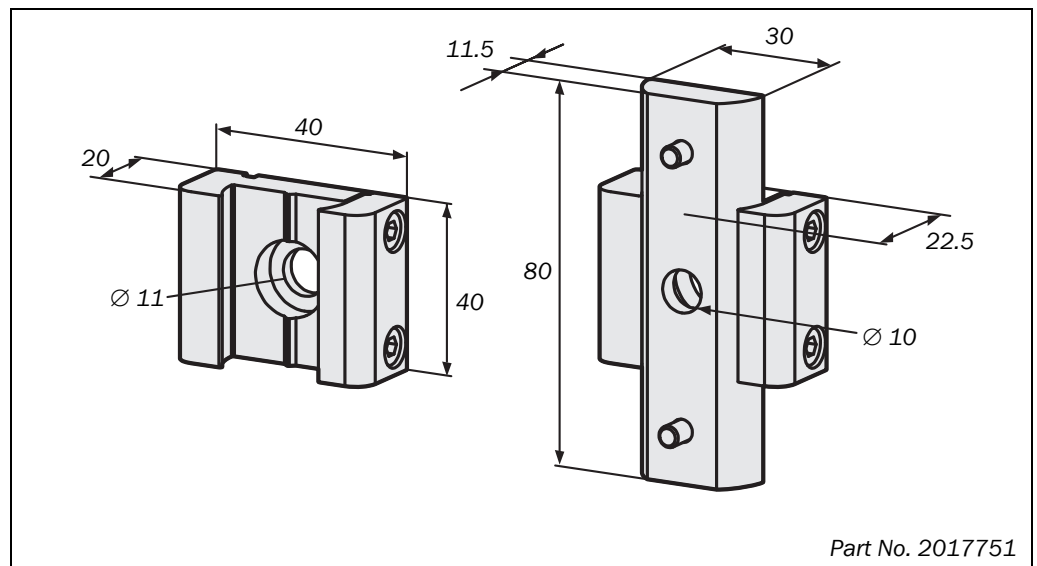

11.3.8 Deflector mirror PNS75-008

Fig. 55: Dimensional drawing deflector mirror PNS75-008 (mm)

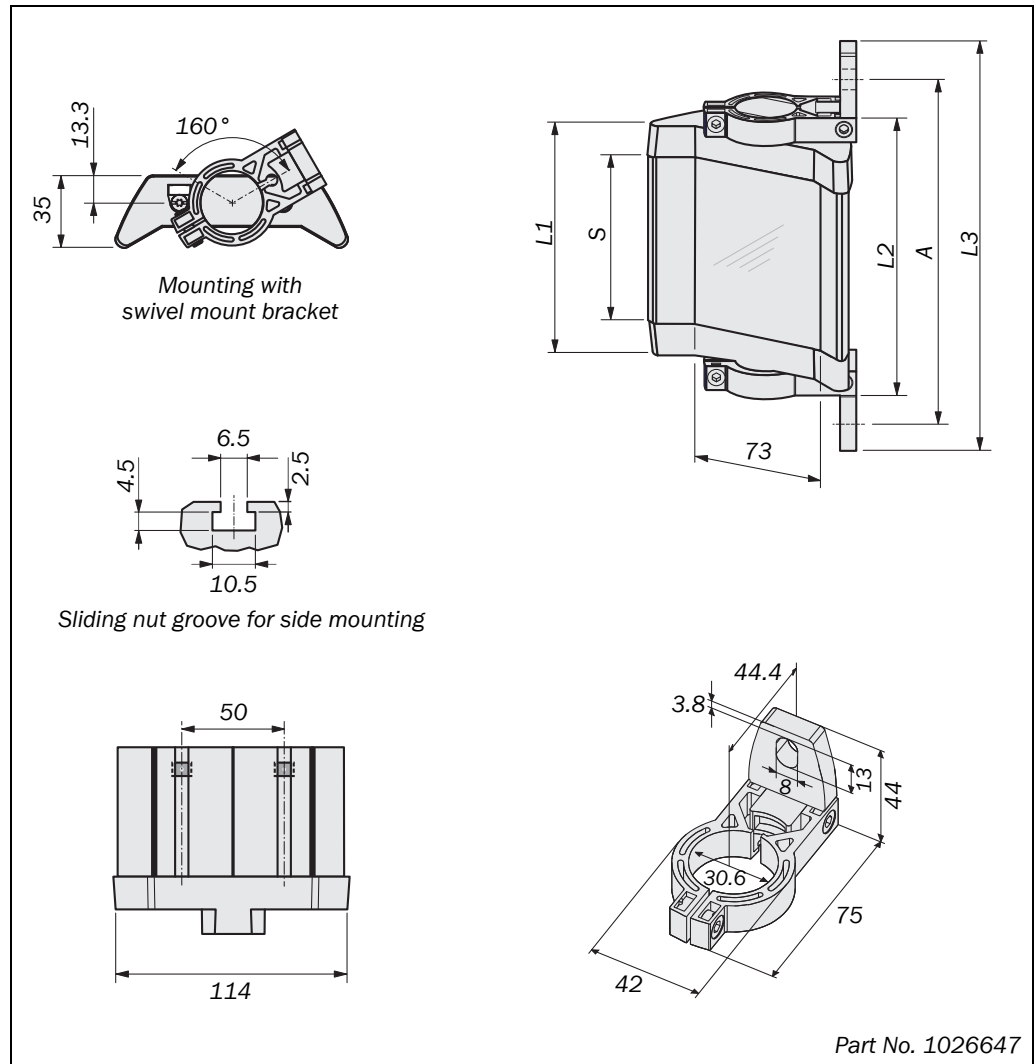

Tab. 33: Dimensions of the deflector mirror PNS75-008

Mirror height S [mm]	Dimension L1 [mm]	Dimension L2 [mm]	Dimension L3 [mm]	Dimension A [mm]
80	112	136	200	180

- Note**
- When using deflector mirrors, the effective scanning range is reduced (see Tab. 8 on page 25).
  - The formation of droplets of heavy contamination can be detrimental to the reflection behaviour. Take the necessary organisational measures to avoid the formation of droplets on the deflector mirrors.
  - The mounting kit is included in the delivery of the deflector mirror PNS75-008.



# 12 Ordering information

## 12.1 M4000 Standard

### 12.1.1 Delivery

Tab. 34: Delivery  
M4000 Standard

☒ Sender	☒ Receiver
<ul style="list-style-type: none"> <li>• sender unit</li> <li>• 4 sliding nuts for side bracket</li> </ul>	<ul style="list-style-type: none"> <li>• receiver unit</li> <li>• 4 sliding nuts for side bracket</li> <li>• label "Important Information"</li> <li>• operating instructions on CD-ROM</li> </ul>

### 12.1.2 Part numbers

#### M4000 Standard with M12 plug

Tab. 35: Part numbers  
M4000 Standard with  
M12 plug

Number of beams	Beam separation [mm]	☒ Sender		☒ Receiver	
		Part number	Type code	Part number	Type code
2	500	1200000	M40S-025000ARO	1200017	M40E-025000RR0
	600	1200001	M40S-026000ARO	1200018	M40E-026000RR0
3	220	1200002	M40S-032200ARO	1200019	M40E-032200RR0
	400	1200003	M40S-034000ARO	1200020	M40E-034000RR0
	450	1200004	M40S-034500ARO	1200021	M40E-034500RR0
4	220	1200005	M40S-042200ARO	1200022	M40E-042200RR0
	300	1200006	M40S-043000ARO	1200023	M40E-043000RR0
5	220	1200007	M40S-052200ARO	1200024	M40E-052200RR0
6	220	1200008	M40S-062200ARO	1200025	M40E-062200RR0
7	220	1200009	M40S-072200ARO	1200026	M40E-072200RR0
8	220	1200010	M40S-082200ARO	1200027	M40E-082200RR0

#### M4000 Standard with M12 plug and integrated alignment aid

Tab. 36: Part numbers  
M4000 Standard with  
M12 plug and integrated  
alignment aid

Number of beams	Beam separation [mm]	☒ Sender		☒ Receiver	
		Part number	Type code	Part number	Type code
2	500	1200011	M40S-025010ARO	1200028	M40E-025010RR0
	600	1200012	M40S-026010ARO	1200029	M40E-026010RR0
3	400	1200013	M40S-034010ARO	1200030	M40E-034010RR0
	450	1200014	M40S-034510ARO	1200031	M40E-034510RR0
4	300	1200015	M40S-043010ARO	1200032	M40E-043010RR0

## M4000 Std., Std. A/P

**M4000 Standard  
with M12 plug and  
end cap with integrated LED<sup>36)</sup>**

Tab. 37: Part numbers  
M4000 Standard with  
M12 plug and end cap with  
integrated LED

Number of beams	Beam separation [mm]	Part number	Type code	Part number	Type code
		☒ Sender		☒ Receiver	
2	500	1200000	M40S-025000ARO	1200033	M40E-025020RR0
	600	1200001	M40S-026000ARO	1200034	M40E-026020RR0
3	400	1200003	M40S-034000ARO	1200035	M40E-034020RR0
	450	1200004	M40S-034500ARO	1200036	M40E-034520RR0
4	300	1200006	M40S-043000ARO	1200037	M40E-043020RR0

**M4000 Standard  
with M12 plug,  
integrated alignment aid and  
end cap with integrated LED<sup>36)</sup>**

Tab. 38: Part numbers  
M4000 Standard with  
M12 plug, integrated  
alignment aid and end cap  
with integrated LED

Number of beams	Beam separation [mm]	Part number	Type code	Part number	Type code
		☒ Sender		☒ Receiver	
2	500	1200011	M40S-025010ARO	1200038	M40E-025030RR0
	600	1200012	M40S-026010ARO	1200039	M40E-026030RR0
3	400	1200013	M40S-034010ARO	1200040	M40E-034030RR0
	450	1200014	M40S-034510ARO	1200041	M40E-034530RR0
4	300	1200015	M40S-043010ARO	1200042	M40E-043030RR0

**12.1.3 Default delivery status**

- Notes**
- The pre-setting for the device configuration is termed the default delivery status. You can accept or change these pre-settings (see chapter 8 “Configuration” on page 69ff.).
  - The default delivery status is only applicable for the device types listed in section 12.1.2 “Part numbers”.

Tab. 39: Default delivery  
status M4000 Standard



Function	Configuration	
	☒ Sender	☒ Receiver
Beam coding	Non-coded	Non-coded
Sender test	Deactivated	-
Restart interlock	-	Internal
External device monitoring (EDM)	-	Activated
Scanning range	-	0.5-20 m
Application diagnostic output (ADO)	-	Contamination

<sup>36)</sup> Receiver only.

## 12.2 M4000 Standard A/P

### 12.2.1 Delivery



Tab. 40: Delivery  
M4000 Standard A/P

  M4000 Standard A/P	M4000 Passive
<ul style="list-style-type: none"> <li>• sender/receiver unit</li> <li>• 4 sliding nuts for side bracket</li> <li>• label "Important Information"</li> <li>• operating instructions on CD-ROM</li> </ul>	<ul style="list-style-type: none"> <li>• deflector unit</li> <li>• 4 sliding nuts for side bracket</li> </ul>

### 12.2.2 Type code



#### M4000 Standard A/P with M12 plug

Tab. 41: Part numbers  
M4000 Standard A/P with  
M12 plug

Num- ber of beams	Beam separa- tion [mm]	Type code	Part number	Type code
		  M4000 Standard A/P		M4000 Passive
2	500	M40Z-025000RR0	1027906	PSD01-1501 <sup>37)</sup>
		M40Z-025000TR0	1027907	PSD01-2501 <sup>38)</sup>
4	300	M40Z-043000TR0	1027908	PSD02-2301 <sup>38)</sup>

#### M4000 Standard A/P with M12 plug and end cap with integrated LED

Tab. 42: Part numbers  
M4000 Standard A/P with  
M12 plug and end cap with  
integrated LED

Num- ber of beams	Beam separa- tion [mm]	Type code	Part number	Type code
		  M4000 Standard A/P		M4000 Passive
2	500	M40Z-025020RR0	1027906	PSD01-1501 <sup>37)</sup>
		M40Z-025020TR0	1027907	PSD01-2501 <sup>38)</sup>
4	300	M40Z-043020TR0	1027908	PSD02-2301 <sup>38)</sup>

<sup>37)</sup> With mirror deflection (max. effective scanning range 7.5 m).

<sup>38)</sup> With fibre-optic deflection (max. effective scanning range 4.5 m).



### 12.2.3 Default delivery status

- Notes**
- The pre-setting for the device configuration is termed the default delivery status. You can accept or change these pre-settings (see chapter 8 “Configuration” on page 69ff.).
  - The default delivery status is only applicable for the device types listed in section 12.2.2 “Type code”.

Tab. 43: Default delivery status M4000 Standard A/P

Function	Configuration M4000 Standard A/P
Beam coding	Non-coded
Restart interlock	Internal
External device monitoring (EDM)	Activated
Scanning range	Preconfigured depending on type
Application diagnostic output (ADO)	Contamination

### 12.3 Additional options

Tab. 44: Additional options

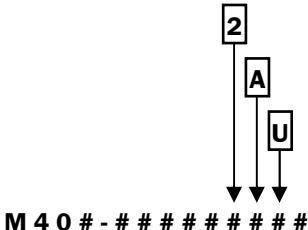
Additional options	Change to the type code
<p><b>Reset connection<sup>39)</sup> M12 socket</b> (only for receiver or M4000 Standard A/P)</p>	
<p><b>Integrated interface AS-Interface Safety at Work<sup>40)</sup></b> (for sender and receiver or M4000 Standard A/P) Default delivery status:</p> <ul style="list-style-type: none"> <li>• <b>Beam coding = non-coded</b> (sender and receiver or M4000 Standard A/P)</li> <li>• <b>Scanning range = low scanning range</b> (receiver or M4000 Standard A/P)</li> </ul>	

- Notes**
- To order additional options, please change the appropriate digit of the type code (see following examples).
  - Please see the ordering information for the related type code (see Tab. 35 ff. on page 94ff.).
  - Note that the additional options *Reset* and *Integrated Interface AS-Interface Safety at Work* cannot be combined.
  - You will also find all available variants in the Internet at [www.sick.com](http://www.sick.com).

<sup>39)</sup> Cannot be combined with the additional option “Integrated Interface AS-Interface Safety at Work”.

<sup>40)</sup> Cannot be combined with the additional option “Additional Reset Connection”.

**Examples:**

1. Ordering the receiver M4000 Standard (receiver type code: e.g. M40E-025000RR0) with the additional option *Reset connection*.

Tab. 45: Example 1 for type code change

	Receiver
Type code for basic device	M 4 0 E - 0 2 5 0 0 0 R R 0
Additional option: <i>Reset connection</i>	<div style="text-align: center;">↓</div> <div style="text-align: center;">T</div> <div style="text-align: center;">↓</div>
Type code for order	M 4 0 E - 0 2 5 0 0 0 R T 0

2. Ordering the M4000 Standard with the additional option *Integrated Interface AS-Interface Safety at Work* (type code sender: e.g. M40S-025000ARO, receiver: e.g. M40E-025000RR0).

Tab. 46: Example 2 for type code change

	Sender	Receiver
Type code for basic device	M 4 0 S - 0 2 5 0 0 0 A R 0	M 4 0 E - 0 2 5 0 0 0 R R 0
Additional option: <i>Integrated interface AS-Interface Safety at Work</i>	<div style="display: flex; justify-content: space-around;"> <div style="text-align: center;">↓</div> <div style="text-align: center;">↓</div> <div style="text-align: center;">↓</div> </div> <div style="display: flex; justify-content: space-around;"> <div style="text-align: center;">2</div> <div style="text-align: center;">A</div> <div style="text-align: center;">U</div> </div> <div style="display: flex; justify-content: space-around;"> <div style="text-align: center;">↓</div> <div style="text-align: center;">↓</div> <div style="text-align: center;">↓</div> </div>	<div style="display: flex; justify-content: space-around;"> <div style="text-align: center;">↓</div> <div style="text-align: center;">↓</div> <div style="text-align: center;">↓</div> </div> <div style="display: flex; justify-content: space-around;"> <div style="text-align: center;">2</div> <div style="text-align: center;">A</div> <div style="text-align: center;">U</div> </div> <div style="display: flex; justify-content: space-around;"> <div style="text-align: center;">↓</div> <div style="text-align: center;">↓</div> <div style="text-align: center;">↓</div> </div>
Type code for order	M 4 0 S - 0 2 5 0 0 2 A U 0	M 4 0 E - 0 2 5 0 0 2 A U 0

Tab. 47: Part numbers  
additional front screens for  
M4000

## 12.4 Additional front screen (weld spark guard)

Description	Part number
Additional front screen for M4000, including sliding nuts and fixing screws, 2 pieces, suitable for: M40#-0250#####	2033225
Additional front screen for M4000, including sliding nuts and fixing screws, 2 pieces, suitable for: M40#-0260#####	2033226
Additional front screen for M4000, including sliding nuts and fixing screws, 2 pieces, suitable for: M40#-0322#####	2033227
Additional front screen for M4000, including sliding nuts and fixing screws, 2 pieces, suitable for: M40#-0340#####	2033228
Additional front screen for M4000, including sliding nuts and fixing screws, 2 pieces, suitable for: M40#-0345#####, M40#-0430#####,	2033229
Additional front screen for M4000, including sliding nuts and fixing screws, 2 pieces, suitable for: M40#-0422#####	2033230
Additional front screen for M4000, including sliding nuts and fixing screws, 2 pieces, suitable for: M40#-0522#####	2033231
Additional front screen for M4000, including sliding nuts and fixing screws, 2 pieces, suitable for: M40#-0622#####	2033232
Additional front screen for M4000, including sliding nuts and fixing screws, 2 pieces, suitable for: M40#-0722#####	2033233
Additional front screen for M4000, including sliding nuts and fixing screws, 2 pieces, suitable for: M40#-0822#####	2033234

- Notes**
- The additional front screens are bolted directly to the mounting groove on the M4000 using the sliding nuts and fixing screws.
  - Each additional front screen fits both on the sender and on the receiver.
  - An additional front screen reduces the scanning range of the system by 8%. If sender and receiver each use an additional front screen, the scanning range will be reduced by 16%.

## 12.5 Deflector mirrors and mirror columns

Tab. 48: Part numbers deflector mirrors and mirror columns

Description	Part number
Deflector mirror PNS75-008, including mounting kit	1026647
Deflector mirror PSK45, including mounting kit, not suitable for column mounting	5306053
Mirror column, fully assembled with mirrors Suitable for M40#-0250#####, 2-beam, 500 mm beam separation	1040619
Mirror column, fully assembled with mirrors Suitable for M40#-0260#####, 2-beam, 600 mm beam separation	1040620
Mirror column, fully assembled with mirrors Suitable for M40#-0340#####, 3-beam, 400 mm beam separation	1040625
Mirror column, fully assembled with mirrors Suitable for M40#-0345#####, 3-beam, 450 mm beam separation	1040624
Mirror column, fully assembled with mirrors Suitable for M40#-0430#####, 4-beam, 300 mm beam separation	1040626
Mirror column, fully assembled with mirrors (45°) Suitable for M40Z-02500#### and M40Z-02501####, 2 beam, beam separation 500 mm	1041917
Adjusting plate Suitable for mirror and device columns	4031053

**Note** Mirror columns affect the scanning range of the system. On this subject see section 4.4 “Scanning range” on page 24ff.

## 12.6 Device columns

Tab. 49: Part numbers device columns

Description	Part number
Stable device columns with 2 exterior mounting grooves for safety light curtains and multiple light beam safety devices	
Column height 985 mm	2045490
Column height 1165 mm	2045641
Column height 1265 mm	2045642
Column height 1720 mm	2045643
Column height 2020 mm	2045644
Column height 2250 mm	2045645
Column height 2400 mm	2045646
Adjusting plate Suitable for mirror and device columns	4031053
Omega bracket for device columns, long, 2 pieces	2045736
Steel plug for floor fastening	5308961

## 12.7 Accessories

Tab. 50: Part numbers accessories

Part	Part number
<p><b>Mounting kits</b></p> <p>Mounting kit 1: mounting bracket rigid, 4 pcs.</p> <p>Mounting kit 2: mounting bracket pivoting, 4 pcs.</p> <p>Mounting kit 6: side bracket pivoting, 4 pcs.</p> <p>Mounting kit 12: swivel-mount bracket pivoting, 4 pcs.</p> <p>Omega bracket for M4000, 4 pcs.</p>	<p>7021352</p> <p>2017751</p> <p>2019506</p> <p>2030510</p> <p>2044846</p>
<p><b>Connecting cables</b></p> <p>For M4000 Standard, M12 plug 8-pin</p> <p>Wire cross-section 0.25 mm<sup>2</sup>, M12 socket 8-pin, PUR halogen-free</p> <p>Socket straight, 2.5 m</p> <p>Socket straight, 5 m</p> <p>Socket straight, 7.5 m</p> <p>Socket straight, 10 m</p> <p>Socket straight, 15 m</p>	<p>6020537</p> <p>6020354</p> <p>6020353</p> <p>6020352</p> <p>6020872</p>
<p>For M4000 Standard with additional <i>Reset</i> connection, M12 socket 5-pin</p> <p>Wire cross-section 0.34 mm<sup>2</sup>, 5-pin M12 plug, PUR halogen-free</p> <p>Plug straight, 2.0 m</p> <p>Plug straight, 5 m</p>	<p>6026133</p> <p>6026134</p>
<p>For M4000 Standard with integrated interface <i>AS-Interface Safety at Work</i>, M12 plug 4-pin</p> <p>Wire cross-section 0.34 mm<sup>2</sup>, M12 plug 3-pin, M12 socket 4-pin (3 contacts), PUR halogen-free</p> <p>Plug straight/socket straight, 0.6 m</p> <p>Plug straight/socket straight, 2 m</p> <p>Plug straight/socket angled, 0.6 m</p> <p>Plug straight/socket angled, 2 m</p>	<p>6025922</p> <p>6025923</p> <p>6025924</p> <p>6025925</p>
<p><b>AS-Interface components and accessories</b></p> <p>AS-Interface clip M12</p> <p>Safe Bus Node UE4215 for ESPE with self-monitored semiconductor outputs (OSSDs)</p> <p>Safe Bus Node UE4212 for safety sensors with contacts</p> <p>AS-Interface Safety at Work monitor UE4233 (1 output signal switching device pair)</p> <p>AS-Interface Safety at Work monitor UE4234 (2 pairs of output signal switching devices)</p> <p>You will find bottom parts for AS-Interface modules for the safe bus nodes as well as other AS-Interface components and accessories in the technical description "SICK AS-Interface Components"</p>	<p>6022472</p> <p>1025687</p> <p>1025814</p> <p>6032490</p> <p>6032491</p> <p>8009362</p>

<b>Part</b>	<b>Part number</b>
<b>External laser alignment aid</b>	
AR60	1015741
Adapter for M4000 housing	4040006
<b>Accessories included in a standard delivery</b>	
Sliding nuts for mounting bracket/side bracket, 4 pcs	2017550
Alignment template for integrated laser alignment aid <sup>41)</sup>	4040263

<sup>41)</sup> Only with devices with integrated laser alignment aid.

# 13 Annex

## 13.1 Compliance with EU directives

### EU declaration of conformity (excerpt)

The undersigned, representing the following manufacturer herewith declares that the product is in conformity with the provisions of the following EU directive(s) (including all applicable amendments), and that the respective standards and/or technical specifications are taken as the basis.

Complete EU declaration of conformity for download: [www.sick.com](http://www.sick.com)

## 13.2 Checklist for the manufacturer

# SICK

### Checklist for the manufacturer/installer for the installation of electro-sensitive protective equipment (ESPE)

Details about the points listed below must be present at least during initial commissioning – they are, however, dependent on the respective application, the specifications of which are to be controlled by the manufacturer/installer.

This checklist should be retained and kept with the machine documentation to serve as reference during recurring tests.

- |  |                              |                             |
|--|------------------------------|-----------------------------|
| 1. Have the safety rules and regulations been observed in compliance with the directives/standards applicable to the machine?  | Yes <input type="checkbox"/> | No <input type="checkbox"/> |
| 2. Are the applied directives and standards listed in the declaration of conformity?   | Yes <input type="checkbox"/> | No <input type="checkbox"/> |
| 3. Does the protective device comply with the required PL/SIL claim limit and PFHd in accordance with EN ISO 13849-1/EN 62061 and the required type in accordance with IEC 61496-1?  | Yes <input type="checkbox"/> | No <input type="checkbox"/> |
| 4. Is access to the hazardous area/hazardous point only possible through the light path/the protective field of the ESPE?  | Yes <input type="checkbox"/> | No <input type="checkbox"/> |
| 5. Have appropriate measures been taken to protect (mechanical protection) or monitor (protective devices) any persons or objects in the hazardous area when protecting a hazardous area or hazardous point, and have these devices been secured or locked to prevent their removal? | Yes <input type="checkbox"/> | No <input type="checkbox"/> |
| 6. Are additional mechanical protective measures fitted and secured against manipulation which prevent reaching under, over or around the ESPE?  | Yes <input type="checkbox"/> | No <input type="checkbox"/> |
| 7. Has the maximum stopping and/or stopping/run-down time of the machine been measured, specified and documented (at the machine and/or in the machine documentation)?   | Yes <input type="checkbox"/> | No <input type="checkbox"/> |
| 8. Has the ESPE been mounted such that the required minimum distance from the nearest hazardous point has been achieved?   | Yes <input type="checkbox"/> | No <input type="checkbox"/> |
| 9. Are the ESPE devices correctly mounted and secured against manipulation after adjustment?   | Yes <input type="checkbox"/> | No <input type="checkbox"/> |
| 10. Are the required protective measures against electric shock in effect (protection class)?  | Yes <input type="checkbox"/> | No <input type="checkbox"/> |
| 11. Is the control switch for resetting the protective equipment (ESPE) or restarting the machine present and correctly installed?   | Yes <input type="checkbox"/> | No <input type="checkbox"/> |
| 12. Are the outputs of the ESPE (OSSD) integrated according to required PL/SILCL compliant with EN ISO 13849-1/EN 62061 and does the integration correspond to the comply with the circuit diagrams?   | Yes <input type="checkbox"/> | No <input type="checkbox"/> |
| 13. Has the protective function been checked in compliance with the test notes of this documentation?  | Yes <input type="checkbox"/> | No <input type="checkbox"/> |
| 14. Are the specified protective functions effective at every operating mode that can be set?  | Yes <input type="checkbox"/> | No <input type="checkbox"/> |
| 15. Are the switching elements activated by the ESPE, e.g. contactors, valves, monitored?  | Yes <input type="checkbox"/> | No <input type="checkbox"/> |
| 16. Is the ESPE effective over the entire period of the dangerous state?   | Yes <input type="checkbox"/> | No <input type="checkbox"/> |
| 17. Is a dangerous state halted when the ESPE is switched on or off, the operating modes are changed over, or when switching over to another protective device?  | Yes <input type="checkbox"/> | No <input type="checkbox"/> |
| 18. Has the information label for the daily check been attached so that it is easily visible for the operator?   | Yes <input type="checkbox"/> | No <input type="checkbox"/> |

**This checklist does not replace the initial commissioning, nor the regular inspection by qualified safety personnel.**



### 13.3 Alignment templates

For the alignment of the M4000 Standard with integrated laser alignment aid you need two alignment templates:

- alignment template for mirrors
- alignment template for the sender

**Note** The alignment templates are in the delivery of the M4000 receiver.<sup>42)</sup> If you no longer have the alignment templates supplied, you can make new templates using the master for copying on the next page.

- Separate the alignment templates along the perforated line.
- Pull the protective film off the self-adhesive strips on the rear of the alignment templates.

Fig. 58: Illustration of the alignment templates

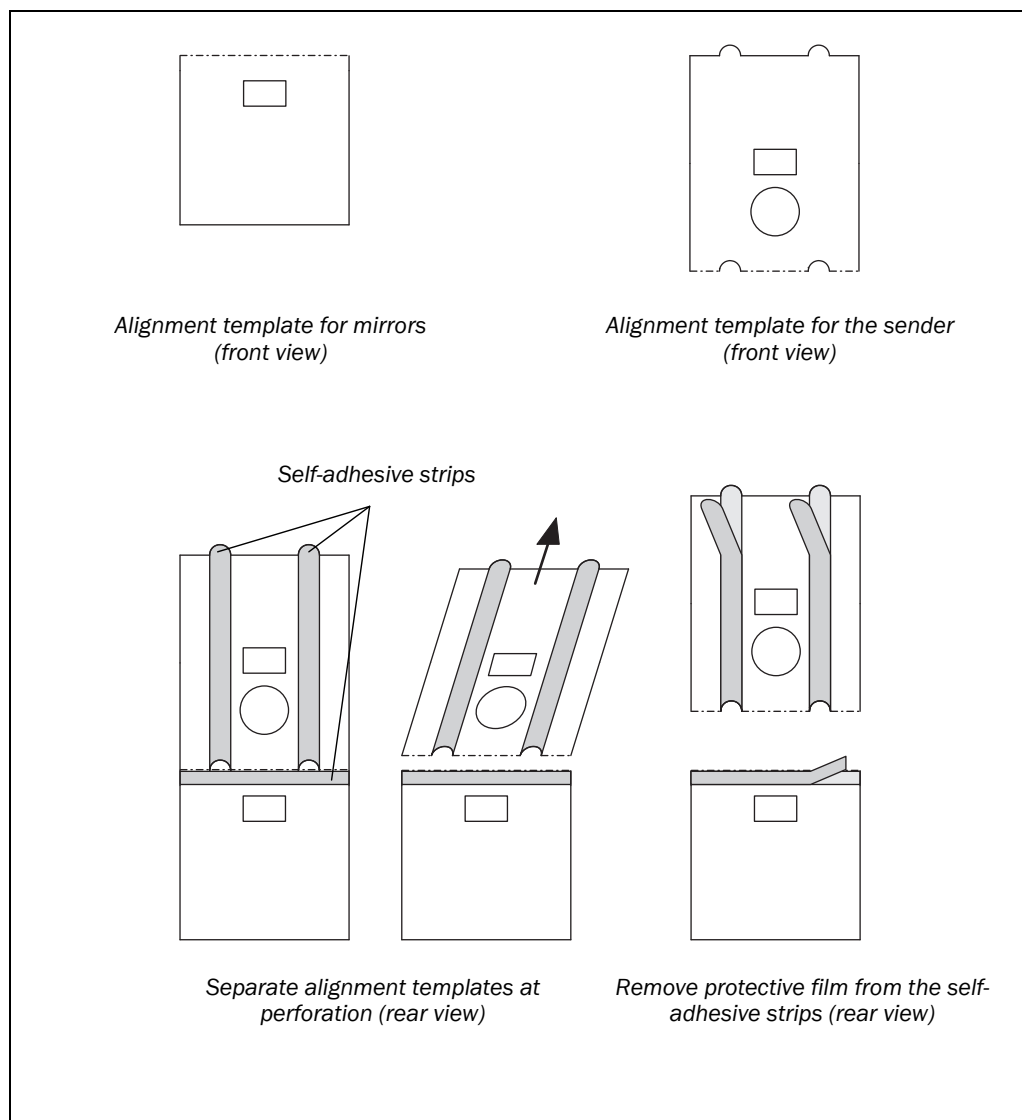

<sup>42)</sup> Only with devices with integrated laser alignment aid.

**How to make the alignment templates:**

- Copy this page.
- Cut the copied template along the edge and at the line marked.
- Cut out the two targets on the laser alignment aid and the circular opening for the beam optics.

Fig. 59: Alignment templates copying master

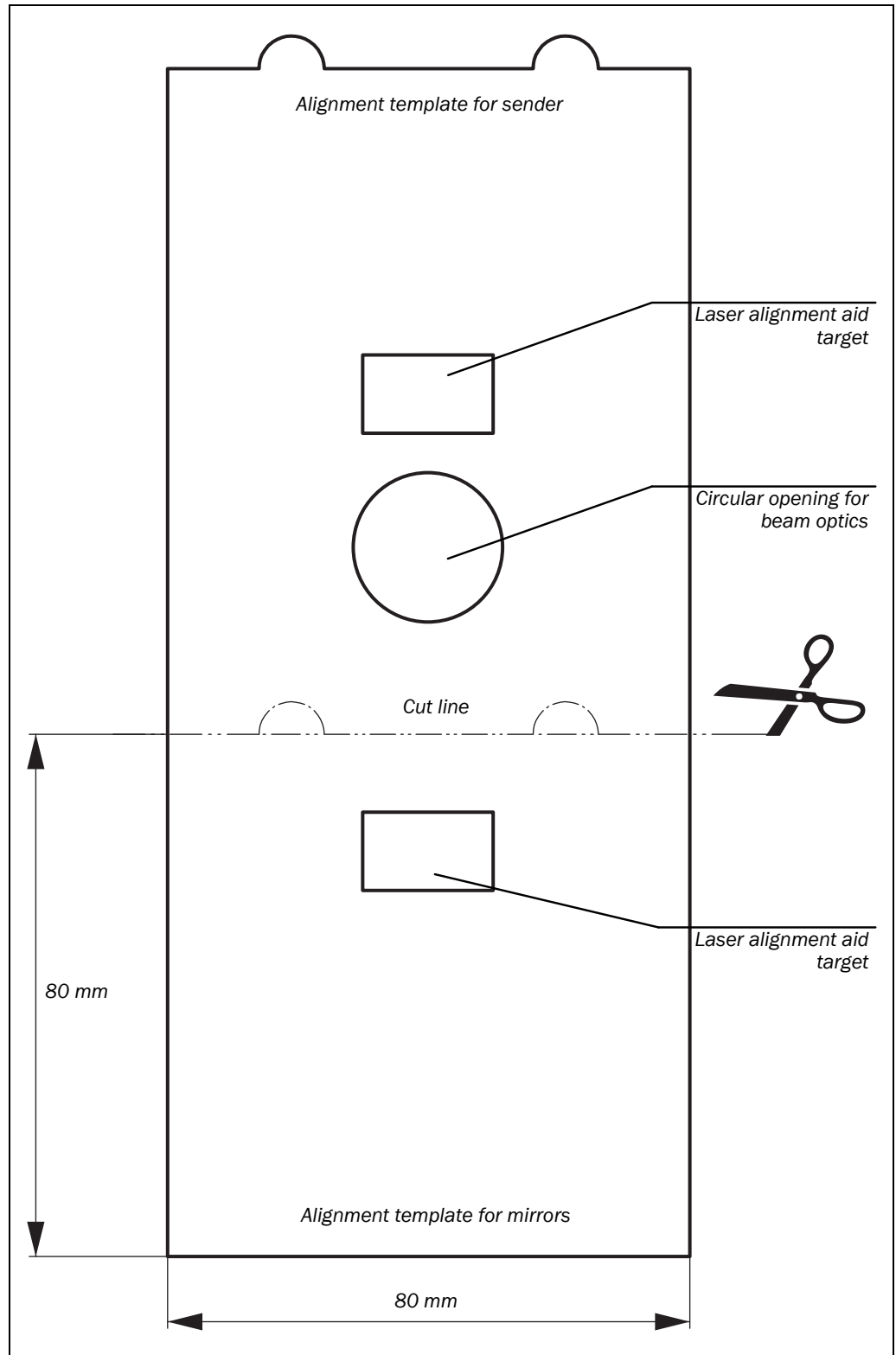

### 13.4 Alignment instructions

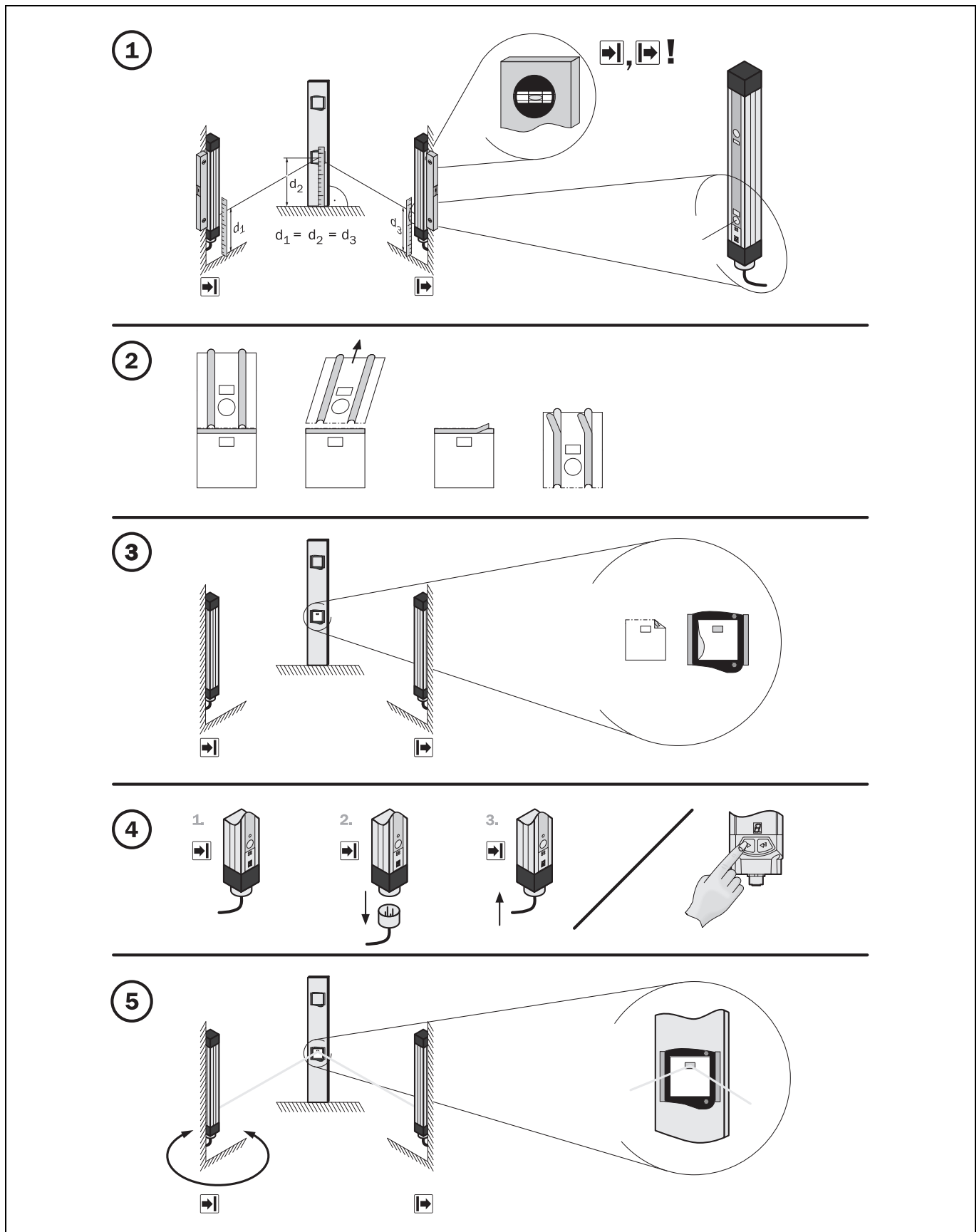

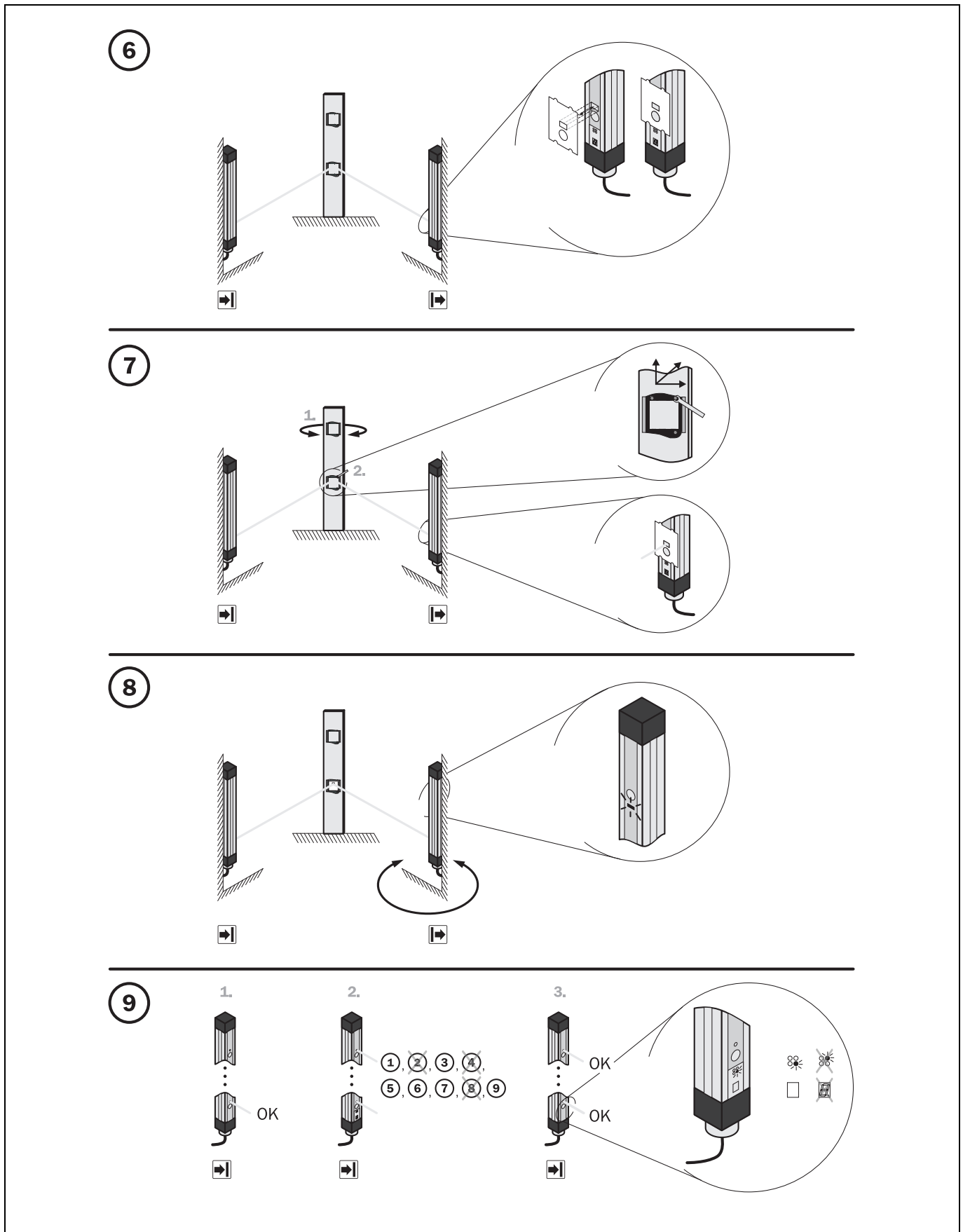

Fig. 60: Alignment instructions copying master

**13.5 List of tables**

Tab. 1:	Overview on disposal by components .....	11
Tab. 2:	Meaning of the configuration buttons.....	17
Tab. 3:	Significance of the indications on the integrated LED .....	18
Tab. 4:	Meaning of the status indicators of the sender.....	19
Tab. 5:	Meaning of the status indicators of the receiver .....	20
Tab. 6:	Permissible configuration of the restart interlock .....	22
Tab. 7:	Possible configuration for the application diagnostic output .....	24
Tab. 8:	Scanning range of the M4000 Standard as a function of the number of deflections per beam and the additional front screens.....	25
Tab. 9:	Scanning range of the M4000 Standard A/P to be configured dependent of the deflector unit used.....	26
Tab. 10:	Maximum effective scanning range of the M4000 Standard A/P as a function of the number of deflections and the number of additional front screens.....	26
Tab. 11:	Device status after the external device monitoring has triggered.....	27
Tab. 12:	Device functions that can be configured on the use of the M4000 with integrated AS-Interface Safety at Work .....	30
Tab. 13:	Equations for calculating the minimum distance S.....	34
Tab. 14:	Formula for the calculation of the minimum distance to reflective surfaces .....	36
Tab. 15:	Pin assignment system connection M4000 Standard or M4000 Standard A/P M12 × 7 + FE.....	50
Tab. 16:	Pin assignment for connection "AS-Interface" M12 × 4 .....	51
Tab. 17:	Pin assignment for connection "Reset" M12 × 5 .....	51
Tab. 18:	Displays shown during the power-up cycle .....	56
Tab. 19:	Overview of the steps for commissioning the M4000 .....	56
Tab. 20:	Indications on the 7-segment display during alignment of the M4000 Standard .....	58
Tab. 21:	Indications on the 7-segment display during alignment of the M4000 Standard A/P.....	59
Tab. 22:	Overview of the configurable functions.....	69
Tab. 23:	Entry of the password on opening the configuration mode .....	70
Tab. 24:	Configuration of the M4000 (menu structure) .....	72
Tab. 25:	Error displays of the LEDs.....	76
Tab. 26:	Error displays of the 7-segment display .....	76
Tab. 27:	Data sheet M4000 Standard and M4000 Standard A/P .....	79
Tab. 28:	Data sheet M4000 Standard and M4000 Standard A/P with integrated AS-Interface Safety at Work .....	83
Tab. 29:	Table of weights M4000 Standard.....	85
Tab. 30:	Table of weights M4000 Passive .....	85
Tab. 31:	Dimensions dependent on the number of beams M4000 Standard.....	87
Tab. 32:	Dimensions of the M4000 Passive dependent on the number of beams.....	89
Tab. 33:	Dimensions of the deflector mirror PNS75-008.....	92
Tab. 34:	Delivery M4000 Standard.....	94

Tab. 35: Part numbers M4000 Standard with M12 plug.....	94
Tab. 36: Part numbers M4000 Standard with M12 plug and integrated alignment aid .....	94
Tab. 37: Part numbers M4000 Standard with M12 plug and end cap with integrated LED.....	95
Tab. 38: Part numbers M4000 Standard with M12 plug, integrated alignment aid and end cap with integrated LED.....	95
Tab. 39: Default delivery status M4000 Standard .....	95
Tab. 40: Delivery M4000 Standard A/P .....	96
Tab. 41: Part numbers M4000 Standard A/P with M12 plug.....	96
Tab. 42: Part numbers M4000 Standard A/P with M12 plug and end cap with integrated LED.....	96
Tab. 43: Default delivery status M4000 Standard A/P.....	97
Tab. 44: Additional options .....	97
Tab. 45: Example 1 for type code change.....	98
Tab. 46: Example 2 for type code change.....	98
Tab. 47: Part numbers additional front screens for M4000 .....	99
Tab. 48: Part numbers deflector mirrors and mirror columns .....	100
Tab. 49: Part numbers device columns.....	100
Tab. 50: Part numbers accessories .....	101

**13.6 List of illustrations**

Fig. 1:	Components of the M4000 Standard .....	13
Fig. 2:	Components of the M4000 Standard A/P.....	13
Fig. 3:	Access protection with a M4000 Standard multiple light beam safety device .....	15
Fig. 4:	Access protection with a M4000 Standard A/P multiple light beam safety device .....	15
Fig. 5:	Access protection with a M4000 Standard multiple light beam safety device and one deflector mirror .....	16
Fig. 6:	Access protection with a M4000 Standard multiple light beam safety device and two deflector mirrors.....	16
Fig. 7:	Access protection with an M4000 Standard A/P multiple light beam safety device and one deflector mirror .....	16
Fig. 8:	Configuration buttons of the M4000 multiple light beam safety device .....	17
Fig. 9:	End cap with integrated LED.....	18
Fig. 10:	Status indicators of the sender .....	19
Fig. 11:	Status indicators of the receiver or of the M4000 Standard A/P .....	20
Fig. 12:	Schematic illustration of the protective operation .....	21
Fig. 13:	Schematic illustration of the beam coding .....	23
Fig. 14:	Minimum distance to the hazardous point for perpendicular approach.....	32
Fig. 15:	Minimum distance to the hazardous point for non-perpendicular approach .....	34
Fig. 16:	Minimum distance to reflective surfaces.....	35
Fig. 17:	Graph, minimum distance from reflective surfaces .....	36
Fig. 18:	Sender and receiver must not be rotated 180° with respect to each other .....	38
Fig. 19:	The correct installation (above) must eliminate the errors (below) of reaching through and crawling beneath .....	38
Fig. 20:	Omega bracket (mm).....	39
Fig. 21:	Mounting with Omega bracket.....	40
Fig. 22:	Composition of the swivel mount bracket.....	40
Fig. 23:	Mounting the M4000 with swivel mount bracket.....	41
Fig. 24:	Composition of the side bracket.....	42
Fig. 25:	Mounting the M4000 with side bracket.....	43
Fig. 26:	Rigid mounting bracket .....	44
Fig. 27:	Mounting the M4000 with rigid mounting bracket.....	45
Fig. 28:	Assembly of the pivoting mounting bracket.....	46
Fig. 29:	Mounting the M4000 with pivoting mounting bracket.....	47
Fig. 30:	Pin assignment system connection M4000 Standard or M4000 Standard A/P M12 × 7 + FE.....	50
Fig. 31:	Pin assignment for connection “AS-Interface” M12 × 4 .....	51
Fig. 32:	Pin assignment for connection “Reset” M12 × 5.....	51
Fig. 33:	Connecting the contact elements to the EDM.....	52
Fig. 34:	Connecting the reset/restart button .....	53
Fig. 35:	Connection of the reset button and the signal lamp “Reset required” to the optional “reset” connection.....	53

Fig. 36: Connection to the application diagnostic output .....	54
Fig. 37: Connection of the sender test button.....	55
Fig. 38: Illustration of the beam order of the M4000 Standard .....	58
Fig. 39: Illustration of the beam order of the M4000 Standard A/P.....	59
Fig. 40: Schematic illustration of the change on slight rotation of the deflector mirror .....	61
Fig. 41: Schematic illustration of the alignment tolerance without and with deflector mirror .....	61
Fig. 42: Attaching the alignment template for mirrors .....	63
Fig. 43: Alignment of the receiver to the deflector mirror using the laser alignment aid .....	63
Fig. 44: Attach the alignment template to the sender .....	64
Fig. 45: Alignment of the deflector mirror to the sender using the laser alignment aid .....	64
Fig. 46: Principle of laser deflection in the sender.....	65
Fig. 47: Alignment of the sender using the laser alignment aid.....	65
Fig. 48: Dimensional drawing M4000 Standard receiver (sender mirror image) or M4000 Standard A/P (mm) .....	86
Fig. 49: Dimensional drawing M4000 Passive (mm) .....	88
Fig. 50: Omega bracket (mm) .....	89
Fig. 51: Dimensional drawing swivel mount bracket (mm).....	90
Fig. 52: Dimensional drawing side bracket (mm).....	90
Fig. 53: Dimensional drawing rigid mounting bracket (mm).....	91
Fig. 54: Dimensional drawing pivoting mounting bracket (mm).....	91
Fig. 55: Dimensional drawing deflector mirror PNS75-008 (mm).....	92
Fig. 56: Dimensional drawing deflector mirror PSK45 (mm).....	93
Fig. 57: Mounting of the deflector mirror PSK45 .....	93
Fig. 58: Illustration of the alignment templates .....	105
Fig. 59: Alignment templates copying master .....	106
Fig. 60: Alignment instructions copying master.....	108









**Australia**

Phone +61 3 9457 0600  
1800 334 802 – tollfree  
E-Mail sales@sick.com.au

**Austria**

Phone +43 (0)22 36 62 28 8-0  
E-Mail office@sick.at

**Belgium/Luxembourg**

Phone +32 (0)2 466 55 66  
E-Mail info@sick.be

**Brazil**

Phone +55 11 3215-4900  
E-Mail marketing@sick.com.br

**Canada**

Phone +1 905 771 14 44  
E-Mail information@sick.com

**Czech Republic**

Phone +420 2 57 91 18 50  
E-Mail sick@sick.cz

**Chile**

Phone +56 2 2274 7430  
E-Mail info@schadler.com

**China**

Phone +86 4000 121 000  
E-Mail info.china@sick.net.cn

**Denmark**

Phone +45 45 82 64 00  
E-Mail sick@sick.dk

**Finland**

Phone +358-9-2515 800  
E-Mail sick@sick.fi

**France**

Phone +33 1 64 62 35 00  
E-Mail info@sick.fr

**Germany**

Phone +49 211 5301-301  
E-Mail info@sick.de

**Great Britain**

Phone +44 (0)1727 831121  
E-Mail info@sick.co.uk

**Hong Kong**

Phone +852 2153 6300  
E-Mail ghk@sick.com.hk

**Hungary**

Phone +36 1 371 2680  
E-Mail office@sick.hu

**India**

Phone +91-22-4033 8333  
E-Mail info@sick-india.com

**Israel**

Phone +972-4-6881000  
E-Mail info@sick-sensors.com

**Italy**

Phone +39 02 27 43 41  
E-Mail info@sick.it

**Japan**

Phone +81 (0)3 5309 2112  
E-Mail support@sick.jp

**Malaysia**

Phone +603 808070425  
E-Mail enquiry.my@sick.com

**Netherlands**

Phone +31 (0)30 229 25 44  
E-Mail info@sick.nl

**New Zealand**

Phone +64 9 415 0459  
0800 222 278 – tollfree  
E-Mail sales@sick.co.nz

**Norway**

Phone +47 67 81 50 00  
E-Mail sick@sick.no

**Poland**

Phone +48 22 837 40 50  
E-Mail info@sick.pl

**Romania**

Phone +40 356 171 120  
E-Mail office@sick.ro

**Russia**

Phone +7-495-775-05-30  
E-Mail info@sick.ru

**Singapore**

Phone +65 6744 3732  
E-Mail sales.gsg@sick.com

**Slovakia**

Phone +421 482 901201  
E-Mail mail@sick-sk.sk

**Slovenia**

Phone +386 (0)1-47 69 990  
E-Mail office@sick.si

**South Africa**

Phone +27 11 472 3733  
E-Mail info@sickautomation.co.za

**South Korea**

Phone +82 2 786 6321  
E-Mail info@sickkorea.net

**Spain**

Phone +34 93 480 31 00  
E-Mail info@sick.es

**Sweden**

Phone +46 10 110 10 00  
E-Mail info@sick.se

**Switzerland**

Phone +41 41 619 29 39  
E-Mail contact@sick.ch

**Taiwan**

Phone +886 2 2375-6288  
E-Mail sales@sick.com.tw

**Thailand**

Phone +66 2645 0009  
E-Mail tawiwat@sicksgp.com.sg

**Turkey**

Phone +90 (216) 528 50 00  
E-Mail info@sick.com.tr

**United Arab Emirates**

Phone +971 (0) 4 88 65 878  
E-Mail info@sick.ae

**USA/Mexico**

Phone +1(952) 941-6780  
1 (800) 325-7425 – tollfree  
E-Mail info@sick.com

**Vietnam**

Phone +84 8 62920204  
E-Mail Ngo.Duy.Linh@sicksgp.com.sg

More representatives and agencies  
at [www.sick.com](http://www.sick.com)